

GROUP 2 SPECIFICATIONS

1. MAJOR COMPONENT

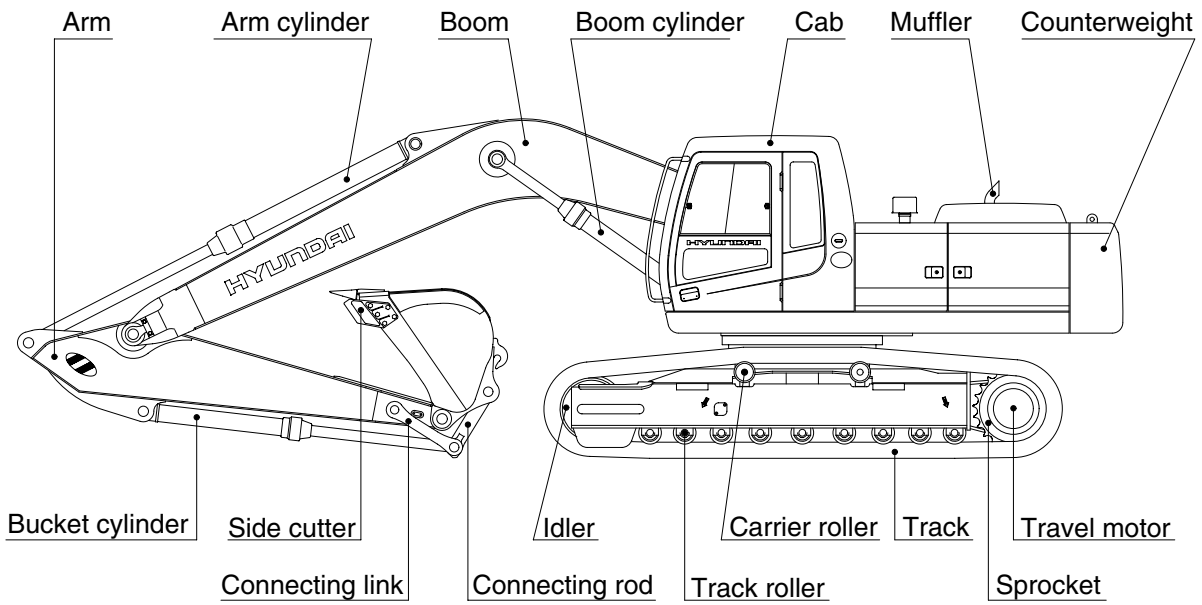
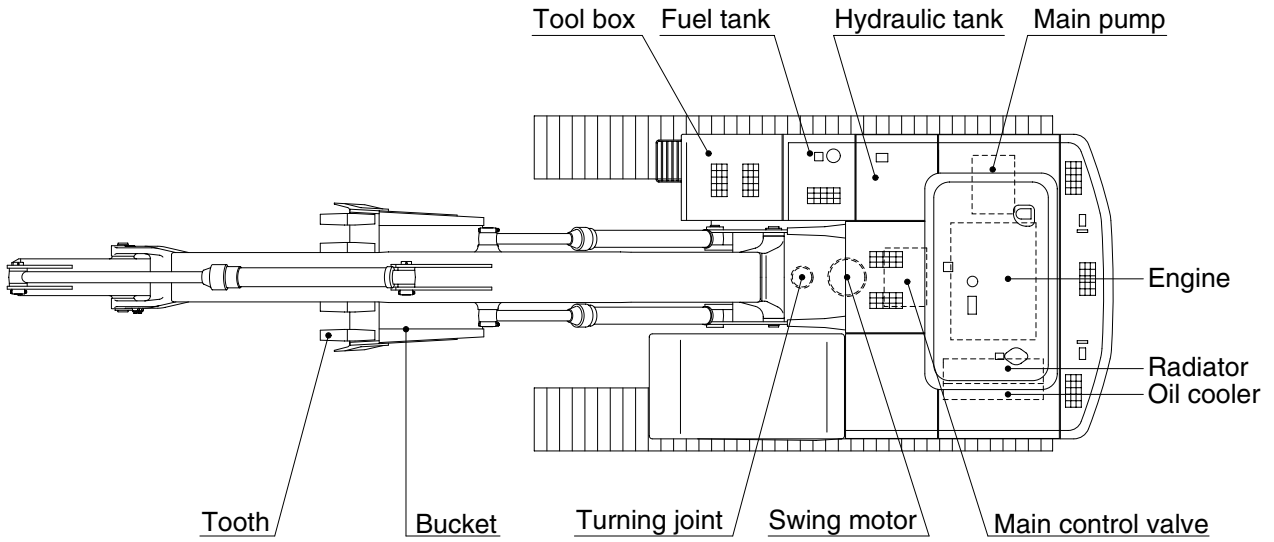

21072SP01A

2. SPECIFICATIONS

1) ROBEX 210LC-7H/220LC-7H

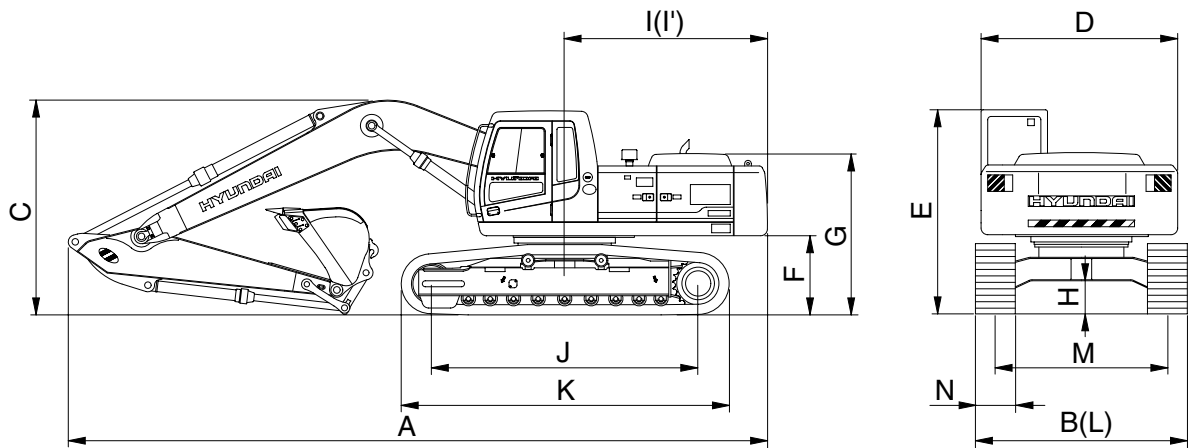

21072SP02

Description		Unit	Specification
Operating weight		kg(lb)	21500(47400)
Bucket capacity(SAE heaped), standard		m ³ (yd ³)	0.92(1.20)
Overall length	A	mm(ft-in)	9520(31' 3")
Overall width, with 600mm shoe	B		2990(9'10")
Overall height	C		2990(9'10")
Superstructure width	D		2700(8'10")
Overall height of cab	E		2920(9' 7")
Ground clearance of counterweight	F		1060(3' 6")
Engine cover height	G		2320(7' 7")
Minimum ground clearance	H		480(1' 7")
Rear-end distance	I		2770(9' 1")
Rear-end swing radius	I'		2830(9' 3")
Distance between tumbler	J		3650(12' 0")
Undercarriage length	K		4440(14' 7")
Undercarriage width	L		2990(9'10")
Track gauge	M		2390(7'10")
Track shoe width, standard	N		600(24")
Travel speed(Low/high)			km/hr(mph)
Swing speed		rpm	12.5
Gradeability		Degree(%)	35(70)
Ground pressure(600mm shoe)		kgf/cm ² (psi)	0.46(6.54)

2) ROBEX 210LC-7H/220LC-7H LONG REACH

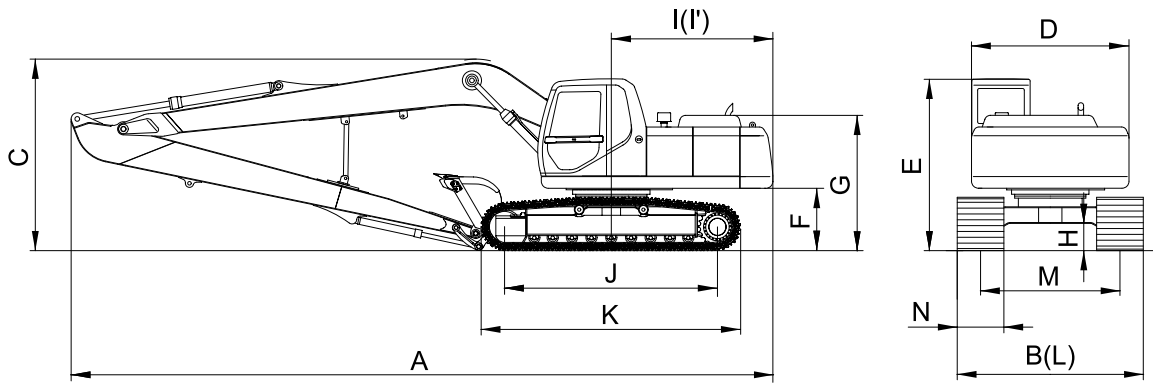

21072SP06

Description	Unit	Specification
Operating weight	kg(lb)	24160(53260)
Bucket capacity(SAE heaped), standard	m ³ (yd ³)	0.51(0.67)
Overall length	A	12030(39' 6")
Overall width, with 800mm shoe	B	3190(10' 6")
Overall height	C	3280(10' 9")
Superstructure width	D	2700(8'10")
Overall height of cab	E	2920(9' 7")
Ground clearance of counterweight	F	1060(3' 6")
Engine cover height	G	2320(7' 7")
Minimum ground clearance	H	480(1' 7")
Rear-end distance	I	2770(9' 1")
Rear-end swing radius	I'	2830(9' 3")
Distance between tumblers	J	3650(12' 0")
Undercarriage length	K	4440(14' 7")
Undercarriage width	L	3190(10' 6")
Track gauge	M	2390(7' 10")
Track shoe width, standard	N	800(31' 5")
Travel speed(Low/high)	km/hr(mph)	3.4/5.3(2.1/3.3)
Swing speed	rpm	12.5
Gradeability	Degree(%)	35(70)
Ground pressure(800mm shoe)	kgf/cm ² (psi)	0.42(5.97)

3. WORKING RANGE

1) R210LC-7H/R220LC-7H [5.68m(18' 8") BOOM]

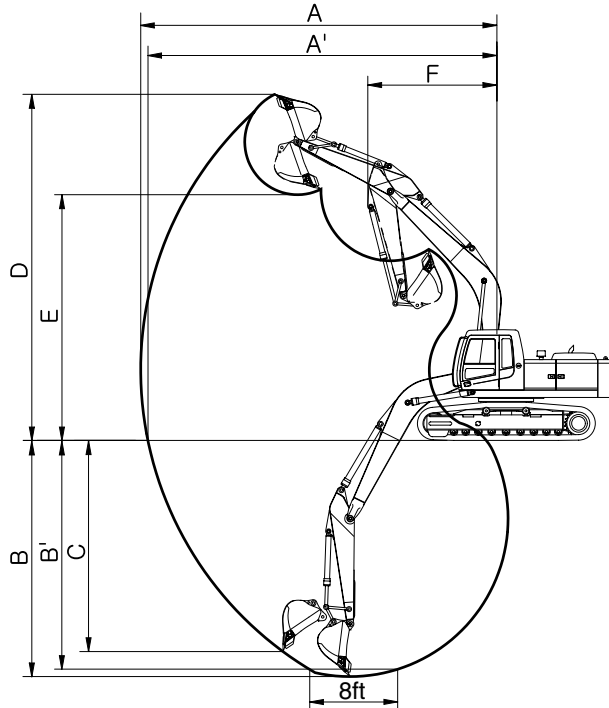

21072SP03

Description		2.0m(6' 7") Arm	2.40m(7'10") Arm	*2.92m(9' 7") Arm	3.90m(12'10") Arm
Max digging reach	A	9140mm (30' 0")	9500mm (31' 2")	9940mm (32' 7")	(35'10")
Max digging reach on ground	A'	8960mm (29' 5")	9330mm (30' 7")	9780mm (32' 1")	(35' 4")
Max digging depth	B	5820mm (19' 1")	6220mm (20' 5")	6740mm (22' 1")	(25' 4")
Max digging depth(8ft level)	B'	5580mm (18' 4")	6010mm (19' 9")	6550mm (21' 6")	(24'10")
Max vertical wall digging depth	C	5280mm (17' 4")	5720mm (18' 9")	6120mm (20' 1")	(23' 9")
Max digging height	D	9140mm (30' 0")	9340mm (30' 8")	9470mm (31' 1")	(33' 2")
Max dumping height	E	6330mm (20' 9")	6520mm (21' 5")	6670mm (21' 1")	(23'11")
Min swing radius	F	3750mm (12' 4")	3740mm (12' 3")	3640mm (11'11")	(11'12")
Bucket digging force	SAE	133 [146]kN	133 [146]kN	133 [146]kN	133 [146]kN
		13600 [14840]kgf	13600 [14840]kgf	13600 [14840]kgf	13600 [14840]kgf
		29980 [32710]lbf	29980 [32710]lbf	29980 [32710]lbf	29980 [32710]lbf
	ISO	152 [166]kN	152 [166]kN	152 [166]kN	152 [166]kN
		15500 [16910]kgf	15500 [16910]kgf	15500 [16910]kgf	15500 [16910]kgf
		34170 [37280]lbf	34170 [37280]lbf	34170 [37280]lbf	34170 [37280]lbf
Arm digging force	SAE	135 [148]kN	113 [123]kN	97 [106]kN	79 [87]kN
		13800 [15050]kgf	11500 [12550]kgf	9900 [10800]kgf	8100 [8840]kgf
		30420 [33190]lbf	25350 [27650]lbf	21830 [23810]lbf	17860 [19480]lbf
	ISO	142 [155]kN	118 [128]kN	101 [110]kN	85 [93]kN
		14500 [15820]kgf	12000 [13090]kgf	10300 [11240]kgf	8700 [9490]kgf
		31970 [34880]lbf	26460 [28870]lbf	22710 [24770]lbf	19170 [20910]lbf

[] : Power boost

* : Standard

2) R210LC-7H/R220LC-7H LONG REACH [8.2m(26' 11") BOOM]

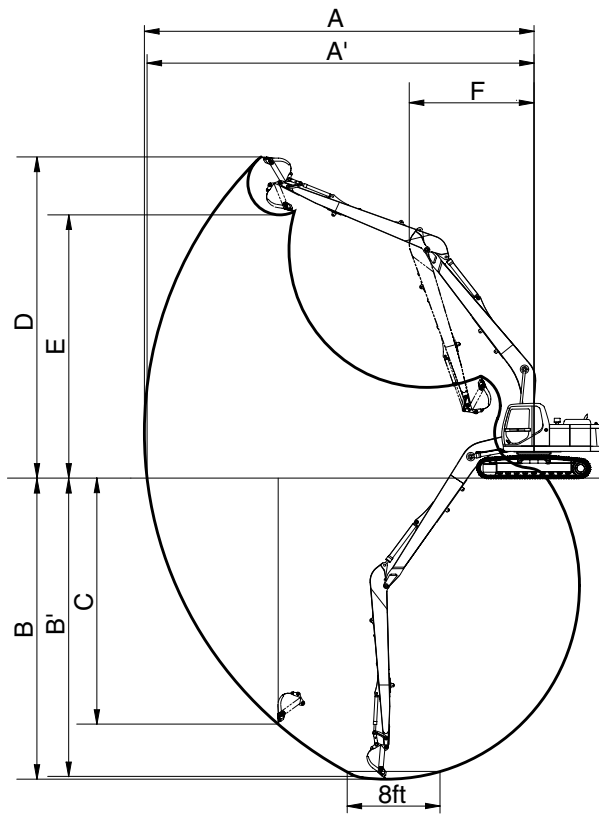

29072SP08

Description		6.3m(20' 8") Arm
Max digging reach	A	15220(50' 0")
Max digging reach on ground	A'	15120(49' 7")
Max digging depth	B	11760(38' 7")
Max digging depth (8ft level)	B'	11650(38' 3")
Max vertical wall digging depth	C	9610(31' 6")
Max digging height	D	12550(41' 2")
Max dumping height	E	10280(33' 8")
Min swing radius	F	4870(16' 0")
Bucket digging force	SAE	72.6 kN
		7400 kgf
		16310 lbf
	ISO	83.4 kN
		8500 kgf
		18740 lbf
Arm crowd force	SAE	49.0 kN
		5000 kgf
		11020 lbf
	ISO	50.0 kN
		5100 kgf
		11240 lbf

4. WEIGHT

1) R210LC-7H/R220LC-7H

Item	R210LC-7H/R220LC-7H	
	kg	lb
Upperstructure assembly	8950	19730
Main frame weld assembly	2600	5730
Engine assembly	530	1170
Main pump assembly	120	265
Main control valve assembly	200	440
Swing motor assembly	250	550
Hydraulic oil tank assembly	240	530
Fuel tank assembly	200	440
Counterweight	3800	8380
Cab assembly	310	680
Lower chassis assembly	8700	19180
Track frame weld assembly	2600	5730
Swing bearing	260	570
Travel motor assembly	310	680
Turning joint	55	120
Track recoil spring and idler	270	600
Idler	170	370
Carrier roller	20	45
Track roller	40	85
Track-chain assembly(600mm standard triple grouser shoe)	1320	2910
Front attachment assembly(5.68m boom, 2.92m arm, 0.92m ³ SAE heaped bucket)	4000	8820
5.68m boom assembly	1535	3380
2.92m arm assembly	710	1570
0.92m ³ SAE heaped bucket	765	1690
Boom cylinder assembly	180	400
Arm cylinder assembly	290	640
Bucket cylinder assembly	175	390
Bucket control link assembly	170	370

2) R210LC-7H/R220LC-7H LONG REACH











Item	LONG REACH	
	kg	lb
Upperstructure assembly	8950	19730
Main frame weld assembly	2600	5730
Engine assembly	530	1170
Main pump assembly	120	265
Main control valve assembly	200	440
Swing motor assembly	250	550
Hydraulic oil tank assembly	240	530
Fuel tank assembly	200	440
Counterweight	5300	11680
Cab assembly	310	680
Lower chassis assembly	8700	19180
Track frame weld assembly	2720	5730
Swing bearing	260	570
Travel motor assembly	310	680
Turning joint	55	120
Track recoil spring and idler	270	600
Idler	170	370
Carrier roller	20	45
Track roller	40	85
Track-chain assembly(800mm standard triple grouser shoe)	1605	3540
Front attachment assembly(8.2m boom, 6.3m arm, 0.51m ³ SAE heaped bucket)	4250	9370
8.2m boom assembly	2470	5450
6.3m arm assembly	1340	2950
0.51m ³ SAE heaped bucket	440	970
Boom cylinder assembly	180	400
Arm cylinder assembly	270	600
Bucket cylinder assembly	130	290
Bucket control rod assembly	170	370

5. LIFTING CAPACITIES

1) ROBEX 210LC-7H/220LC-7H













(1) 5.68m(18' 8") boom, 2.00m(6' 7") arm equipped with 0.92m³(SAE heaped) bucket, 600mm (24") triple grouser shoe and 3800kg counterweight.

-  : Rating over-front
-  : Rating over-side or 360 degree













Load point height		Load radius								At max. reach		
		3.0m(10ft)		4.5m(15ft)		6.0m(20ft)		7.5m(25ft)		Capacity		Reach
												m(ft)
7.5m (25ft)	kg lb									*3750 *8270	*3750 *8270	6.64 (21.8)
6.0m (20ft)	kg lb					*4150 *9150	*4150 *9150			*3800 *8380	3060 6750	7.78 (25.5)
4.5m (15ft)	kg lb			*5360 *11820	*5360 *11820	*4540 *10010	*4540 *10010			*3910 *8620	2560 5640	8.43 (27.7)
3.0m (10ft)	kg lb			*6970 *15370	6830 15060	*5240 *11550	4380 9660	*4500 *9920	3020 6660	*4050 *8930	2340 5160	8.74 (28.7)
1.5m (5ft)	kg lb			*8380 *18470	6310 13910	*5950 *13120	4120 9080	*4820 *10630	2900 6390	4000 8820	2280 5030	8.73 (28.6)
Ground Line	kg lb			*9020 *19890	6080 13400	*6430 *14180	3960 8730	4980 10980	2830 6240	4210 9280	2400 5290	8.42 (27.6)
-1.5m (-5ft)	kg lb	*13020 *28700	12190 26870	*8960 *19750	6050 13340	*6510 *14350	3910 8620			*4550 *10030	2770 6110	7.76 (25.5)
-3.0m (-10ft)	kg lb	*11620 *25620	*11620 *25620	*8210 *18100	6160 13580	*5910 *13030	3990 8800			*4510 *9940	3660 8070	6.61 (21.7)
-4.5m (-15ft)	kg lb	*8770 *19330	*8770 *19330									

- Note
1. Lifting capacity are based on SAE J1097 and ISO 10567.
 2. Lifting capacity of the ROBEX series does not exceed 75% of tipping load with the machine on firm, level ground or 87% of full hydraulic capacity.
 3. The load point is a hook located on the back of the bucket.
 4. *indicates load limited by hydraulic capacity.

(2) 5.68m(18' 8") boom, 2.40m(7' 10") arm equipped with 0.92m³(SAE heaped) bucket, 600mm (24") triple grouser shoe and 3800kg counterweight.

Load point height		Load radius										At max. reach					
		1.5m(5ft)		3.0m(10ft)		4.5m(15ft)		6.0m(20ft)		7.5m(25ft)		Capacity		Reach			
														m(ft)			
7.5m (25ft)	kg lb														*3450 *7610	*3450 *7610	7.15 (23.5)
6.0m (20ft)	kg lb							*3750 *8270	*3750 *8270						*3520 *7760	2780 6130	8.20 (26.9)
4.5m (15ft)	kg lb							*4190 *9240	*4190 *9240	*3940 *8690	3140 6920				*3630 *8000	2350 5180	8.82 (28.9)
3.0m (10ft)	kg lb					*6420 *14150	*6420 *14150	*4920 *10850	4400 9700	*4240 *9350	3020 6660				3770 8310	2150 4740	9.11 (29.9)
1.5m (5ft)	kg lb					*7960 *17550	6360 14020	*5690 *12540	4130 9110	*4620 *10190	2890 6370				3720 8200	2100 4630	9.10 (29.9)
Ground Line	kg lb			*8300 *18300	*8300 *18300	*8820 *19440	6050 13340	*6260 *13800	3930 8660	*4920 *10850	2790 6150				3890 8580	2200 4850	8.81 (28.9)
-1.5m (-5ft)	kg lb	*9220 *20330	*9220 *20330	*12750 *28110	11960 26370	*8970 *19780	5970 13160	*6460 *14240	3850 8490						*4300 *9480	2490 5490	8.18 (26.8)
-3.0m (-10ft)	kg lb	*13340 *29410	*13340 *29410	*12280 *27070	12180 26850	*8430 *18580	6040 13320	*6110 *13470	3890 8580						*4360 *9610	3190 7030	7.12 (23.4)
-4.5m (-15ft)	kg lb			*9840 *21690	*9840 *21690	*6850 *15100	6300 13890										











(3) 5.68m(18' 8") boom, 2.92m(9' 7") arm equipped with 0.92m³(SAE heaped) bucket, 600mm (24") triple grouser shoe and 3800kg counterweight.

Load point height		Load radius										At max. reach					
		1.5m(5ft)		3.0m(10ft)		4.5m(15ft)		6.0m(20ft)		7.5m(25ft)		Capacity		Reach			
														m(ft)			
7.5m (25ft)	kg lb														*3120 *6880	*3120 *6880	7.72 (25.3)
6.0m (20ft)	kg lb														*3210 *7080	2530 5580	8.69 (28.5)
4.5m (15ft)	kg lb							*3770 *8310	*3770 *8310	*3590 *7910	3210 7080				*3340 *7360	2170 4780	9.27 (30.4)
3.0m (10ft)	kg lb			*9160 *20190	*9160 *20190	*5760 *12700	*5760 *12700	*4530 *9990	4490 9900	*3950 *8710	3070 6770				*3490 *7690	1980 4370	9.55 (31.3)
1.5m (5ft)	kg lb			*8660 *19090	*8660 *19090	*7430 *16380	6500 14330	*5380 *11860	4180 9220	*4390 *9680	2910 6420				3440 7580	1930 4250	9.54 (31.3)
Ground Line	kg lb			*9310 *20530	*9310 *20530	*8550 *18850	6100 13450	*6060 *13360	3950 8710	*4770 *10520	2780 6130				3580 7890	2000 4410	9.26 (30.4)
-1.5m (-5ft)	kg lb	*8550 *18850	*8550 *18850	*12160 *26810	11830 26080	*8950 *19730	5940 13100	*6400 *14110	3820 8420	4870 10740	2720 6000				3970 8750	2230 4920	8.67 (28.4)
-3.0m (-10ft)	kg lb	*11700 *25790	*11700 *25790	*13020 *28700	11990 26430	*8680 *19140	5960 13140	*6280 *13850	3820 8420						*4230 *9330	2770 6110	7.69 (25.2)
-4.5m (-15ft)	kg lb			*11040 24340	*11040 *24340	*7560 *16670	6130 13510								*4140 *9130	*4140 *9130	6.09 (20.0)

2) R210LC-7H/R220LC-7H LONG REACH

(1) 8.2m(26' 11") boom, 6.3m(20' 8") arm equipped with 0.51m³(SAE heaped) bucket, 800mm (32") triple grouser shoe and 5300kg counterweight.

-  : Rating over-front
-  : Rating over-side or 360 degree

Load point height		Load radius								At max. reach		
		3.0m(10ft)		6.0m(20ft)		9.0m(30ft)		12.0m(40ft)		Capacity		Reach
												m(ft)
9.0m (30ft)	kg lb							*830 *1830	*830 *1830	*1330 *2930	*1330 *2930	13.11 (43.0)
6.0m (20ft)	kg lb							*1430 *3150	*1430 *3150	*1410 *3110	1120 2470	14.37 (47.1)
3.0m (10ft)	kg lb					*1990 *4390	*1990 *4390	*1670 *3680	1580 3480	*1520 *3350	940 2070	14.89 (48.9)
Ground Line	kg lb	*4560 *10050	*4560 *10050	*4330 *9550	*4330 *9550	*2650 *5840	2360 5200	*1980 *4370	1390 3060	*1670 *3680	890 1960	14.75 (48.4)
-3.0m (-10ft)	kg lb	*5710 *12590	*5710 *12590	*5250 *11570	3800 8380	*3150 *6940	2070 4560	*2220 *4890	1260 2780	*1860 *4100	980 2160	13.92 (45.7)
-6.0m (-20ft)	kg lb	*7790 *17170	*7790 *17170	*5370 *11840	3720 8200	*3280 *7230	1990 4390			*2090 *4610	1280 2820	12.25 (40.2)
-9.0m (-30ft)	kg lb	*8780 *19360	*8780 *19360	*4510 *9940	4000 8820	*2620 *5780	2190 4830					

- Note
1. Lifting capacity are based on SAE J1097 and ISO 10567.
 2. Lifting capacity of the ROBEX series does not exceed 75% of tipping load with the machine on firm, level ground or 87% of full hydraulic capacity.
 3. The load point is a hook located on the back of the bucket.
 4. *indicates load limited by hydraulic capacity.

6. BUCKET SELECTION GUIDE

1) GENERAL BUCKET

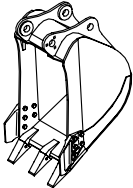
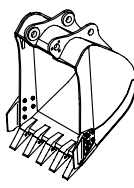
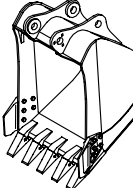
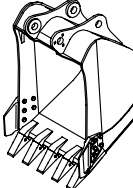
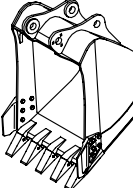
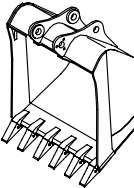
					
0.51m ³ SAE heaped bucket	0.80m ³ SAE heaped bucket	※ 0.92m ³ SAE heaped bucket	1.10m ³ SAE heaped bucket	1.20m ³ SAE heaped bucket	1.34m ³ SAE heaped bucket

Capacity		Width		Weight	Recommendation			
SAE heaped	CECE heaped	Without side cutter	With side cutter		5.68m (18' 8") boom			
					2.0m arm (6' 7")	2.4m arm (7' 10")	2.92m arm (9' 7")	3.90m arm (12' 10")
0.51m ³ (0.67yd ³)	0.45m ³ (0.59yd ³)	700mm (27.6")	820mm (32.3")	570kg (1260lb)				
0.80m ³ (1.05yd ³)	0.70m ³ (0.92yd ³)	1000mm (39.4")	1120mm (44.1")	700kg (1540lb)				
※ 0.92m ³ (1.20yd ³)	0.80m ³ (1.05yd ³)	1150mm (45.3")	1270mm (50.0")	770kg (1700lb)				
1.10m ³ (1.44yd ³)	0.96m ³ (1.26yd ³)	1320mm (52.0")	1440mm (56.7")	830kg (1830lb)				
1.20m ³ (1.57yd ³)	1.00m ³ (1.31yd ³)	1400mm (55.1")	1520mm (59.8")	850kg (1870lb)				
1.34m ³ (1.75yd ³)	1.15m ³ (1.50yd ³)	1550mm (61.0")	1670mm (65.7")	920kg (2030lb)				

※ : Standard bucket

 Applicable for materials with density of 2000kgf/m³ (3370lbf/yd³) or less

 Applicable for materials with density of 1600kgf/m³ (2700lbf/yd³) or less

 Applicable for materials with density of 1100kgf/m³ (1850lbf/yd³) or less

2) HEAVY DUTY, ROCK AND SLOPE FINISHING BUCKET

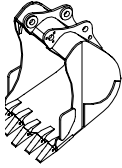
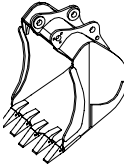
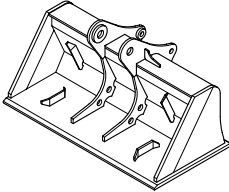
		
◆0.74, 0.90, 1.05m ³ SAE heaped bucket	◎0.87, 1.20m ³ SAE heaped bucket	■0.75m ³ SAE heaped bucket

Capacity		Width		Weight	Recommendation			
SAE heaped	CECE heaped	Without side cutter	With side cutter		5.68m (18' 8") boom			
					2.0m arm (6' 7")	2.4m arm (7' 10")	2.92m arm (9' 7")	3.90m arm (12' 10")
◆0.74m ³ (0.97yd ³)	0.65m ³ (0.85yd ³)	985mm (38.8")	-	770kg (1700lb)				
◆0.90m ³ (1.18yd ³)	0.80m ³ (1.05yd ³)	1070mm (42.0")	-	810kg (1790lb)				
◆1.05m ³ (1.37yd ³)	0.92m ³ (1.20yd ³)	1290mm (50.8")	-	890kg (1960lb)				
◎0.87m ³ (1.14yd ³)	0.75m ³ (0.98yd ³)	1140mm (44.9")	-	900kg (1980lb)				
◎1.20m ³ (1.57yd ³)	1.00m ³ (1.31yd ³)	1410mm (55.5")	-	1030kg (2270lb)				
■0.75m ³ (0.98yd ³)	0.65m ³ (0.85yd ³)	1790mm (70.5")	-	880kg (1940lb)				

◆ : Heavy duty bucket ◎ : Rock bucket(Heavy) ■ : Slope finishing bucket

Applicable for materials with density of 2000kgf/m³ (3370lbf/yd³) or less

Applicable for materials with density of 1600kgf/m³ (2700lbf/yd³) or less

Applicable for materials with density of 1100kgf/m³ (1850lbf/yd³) or less

7. UNDERCARRIAGE

1) TRACKS

X-leg type center frame is integrally welded with reinforced box-section track frames. The design includes dry tracks, lubricated rollers, idlers, sprockets, hydraulic track adjusters with shock absorbing springs and assembled track-type tractor shoes with triple grousers.

2) TYPES OF SHOES

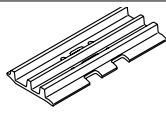
Model	Shapes		Triple grouser			
						
R210LC-7H R220LC-7H	Shoe width	mm(in)	600(24)	700(28)	800(32)	-
	Operating weight	kg(lb)	21500(47400)	21780(48020)	22070(48660)	-
	Ground pressure	kgf/cm ² (psi)	0.46(6.54)	0.40(5.69)	0.35(4.98)	-
	Overall width	mm(ft-in)	2990(9' 10")	3090(10' 2")	3190(10' 6")	-
R210LC-7H R220LC-7H LONG REACH	Shoe width	mm(in)	-	-	800(32)	-
	Operating weight	kg(lb)	-	-	24360(53700)	-
	Ground pressure	kgf/cm ² (psi)	-	-	0.42(5.97)	-
	Overall width	mm(ft-in)	-	-	3190(10' 6")	-

3) NUMBER OF ROLLERS AND SHOES ON EACH SIDE

Item	Quantity
Carrier rollers	2EA
Track rollers	9EA
Track shoes	49EA

4) SELECTION OF TRACK SHOE

Suitable track shoes should be selected according to operating conditions.

Method of selecting shoes

Confirm the category from the list of applications in **table 2**, then use **table 1** to select the shoe. Wide shoes(Categories B and C) have limitations on applications. Before using wide shoes, check the precautions, then investigate and study the operating conditions to confirm if these shoes are suitable.

Select the narrowest shoe possible to meet the required flotation and ground pressure. Application of wider shoes than recommendations will cause unexpected problem such as bending of shoes, crack of link, breakage of pin, loosening of shoe bolts and the other various problems.

※ **Table 1**

Track shoe	Specification	Category
600mm triple grouser	Standard	A
700mm triple grouser	Option	B
800mm triple grouser	Option	C
800mm triple grouser(Long reach)	Standard	C

※ **Table 2**

Category	Applications	Precautions
A	Rocky ground, river beds, normal soil	<ul style="list-style-type: none"> Travel at low speed on rough ground with large obstacles such as boulders or fallen trees
B	Normal soil, soft ground	<ul style="list-style-type: none"> These shoes cannot be used on rough ground with large obstacles such as boulders or fallen trees Travel at high speed only on flat ground Travel slowly at low speed if it is impossible to avoid going over obstacles
C	Extremely soft ground (Swampy ground)	<ul style="list-style-type: none"> Use the shoes only in the conditions that the machine sinks and it is impossible to use the shoes of category A or B These shoes cannot be used on rough ground with large obstacles such as boulders or fallen trees Travel at high speed only on flat ground Travel slowly at low speed if it is impossible to avoid going over obstacles

8. SPECIFICATIONS FOR MAJOR COMPONENTS

1) ENGINE

Item		Specification
Model		HYUNDAI D6BT-C
Type		4-cycle turbocharged diesel engine
Cooling method		Water cooling
Number of cylinders and arrangement		6 cylinders, in-line
Firing order		1-5-3-6-2-4
Combustion chamber type		Direct injection type
Cylinder bore × stroke		118 × 115mm(4.65" × 4.53")
Piston displacement		7545cc(460cu in)
Compression ratio		16 : 1
Rated gross horse power(SAE J1349)	R210LC-7H	145Ps at 1950rpm(107kW at 1950rpm)
	R220LC-7H	159Ps at 1950rpm(117kW at 1950rpm)
Maximum torque at 1600rpm		57kgf · m(412lb · ft)
Engine oil quantity		16.3 l (4.3U.S. gal)
Dry weight		530kg(1168lb)
High idling speed		2150+ 100rpm
Low idling speed		900 ± 100rpm
Rated fuel consumption		156g/Ps · hr at 1600rpm
Starting motor		24V-5kW
Alternator		24V-70A
Battery		2 × 12V × 100Ah

2) MAIN PUMP

Item		Specification
Type		Variable displacement tandem axis piston pumps
Capacity		2 × 113cc/rev
Maximum pressure		330kgf/cm ² (4694psi) [360kgf/cm ² (5120psi)]
Rated oil flow		2 × 220 l /min (58.1U.S. gpm/ 48.4U.K. gpm)
Rated speed		1950rpm

[] : Power boost

3) GEAR PUMP

Item	Specification
Type	Fixed displacement gear pump single stage
Capacity	15cc/rev
Maximum pressure	35kgf/cm ² (500psi)
Rated oil flow	29.3 l /min(7.7U.S. gpm/6.4U.K. gpm)

4) MAIN CONTROL VALVE

Item	Specification
Type	9 spools mono-block
Operating method	Hydraulic pilot system
Main relief valve pressure	330kgf/cm ² (4695psi) [360kgf/cm ² (5120psi)]
Overload relief valve pressure	390kgf/cm ² (5550psi)

[]: Poer boost

5) SWING MOTOR

Item	Specification
Type	Two fixed displacement axial piston motor
Capacity	148.5cc/rev
Relief pressure	240kgf/cm ² (3414psi)
Braking system	Automatic, spring applied hydraulic released
Braking torque	63kgf · m(456lb · ft)
Brake release pressure	16~23kgf/cm ² (228~327psi)
Reduction gear type	2 - stage planetary
Swing speed	12.5rpm

6) TRAVEL MOTOR

Item	Specification
Type	Variable displacement axial piston motor
Relief pressure	330kgf/cm ² (4695psi)
Reduction gear type	2-stage planetary
Braking system	Automatic, spring applied hydraulic released
Brake release pressure	11kgf/cm ² (156psi)
Braking torque	49.3kgf · m(357lb · ft)

7) REMOTE CONTROL VALVE

Item		Specification
Type		Pressure reducing type
Operating pressure	Minimum	6.5kgf/cm ² (92psi)
	Maximum	26kgf/cm ² (370psi)
Single operation stroke	Lever	61mm(2.4in)
	Pedal	123mm(4.84in)

8) CYLINDER

Item		Specification
Boom cylinder	Bore dia × Rod dia × Stroke	∅ 120 × ∅ 85 × 1290mm
	Cushion	Extend only
Arm cylinder	Bore dia × Rod dia × Stroke	∅ 140 × ∅ 100 × 1510mm # ∅ 140 × ∅ 95 × 1460mm
	Cushion	Extend and retract
Bucket cylinder	Bore dia × Rod dia × Stroke	∅ 125 × ∅ 85 × 1055mm # ∅ 100 × ∅ 70 × 870mm
	Cushion	Extend only

※ Discoloration of cylinder rod can occur when the friction reduction additive of lubrication oil spreads on the rod surface.

※ Discoloration does not cause any harmful effect on the cylinder performance.

: LONG REACH

9) SHOE

Item		Width	Ground pressure	Link quantity	Overall width
R210LC-7H R220LC-7H	Standard	600mm(24")	0.46kgf/cm ² (6.54psi)	49	2990mm(9' 10")
	Option	700mm(28")	0.40kgf/cm ² (5.69psi)	49	3090mm(10' 2")
		800mm(32")	0.35kgf/cm ² (4.98psi)	49	3190mm(10' 6")
R210LC-7H R220LC-7H LONG REACH	Standard	800mm(32")	0.42kgf/cm ² (5.97psi)	49	3190mm(10' 6")

10) BUCKET

Item		Capacity		Tooth quantity	Width	
		SAE heaped	CECE heaped		Without side cutter	With side cutter
R210LC-7H R220LC-7H	STD	0.92m ³ (1.20yd ³)	0.80m ³ (1.05yd ³)	5	1150mm(45.3")	1270mm(50.0")
	OPT	0.51m ³ (0.67yd ³)	0.45m ³ (0.59yd ³)	3	700mm(27.6")	820mm(32.3")
		0.80m ³ (1.05yd ³)	0.70m ³ (0.92yd ³)	5	1000mm(39.4")	1120mm(44.1")
		1.10m ³ (1.44yd ³)	0.96m ³ (1.26yd ³)	5	1320mm(52.0")	1440mm(56.7")
		1.20m ³ (1.57yd ³)	1.00m ³ (1.31yd ³)	6	1400mm(55.1")	1520mm(59.8")
		1.34m ³ (1.75yd ³)	1.15m ³ (1.50yd ³)	6	1550mm(61.0")	1670mm(65.7")
		◆0.74m ³ (0.97yd ³)	0.65m ³ (0.85yd ³)	5	985mm(38.8")	-
		◆0.90m ³ (1.18yd ³)	0.80m ³ (1.05yd ³)	5	1070mm(42.0")	-
		◆1.05m ³ (1.37yd ³)	0.92m ³ (1.20yd ³)	5	1290mm(50.8")	-
		◎0.87m ³ (1.14yd ³)	0.75m ³ (0.98yd ³)	5	1140mm(44.9")	-
		◎1.20m ³ (1.57yd ³)	1.00m ³ (1.31yd ³)	5	1410mm(55.5")	-
		■0.75m ³ (0.98yd ³)	0.65m ³ (0.85yd ³)	-	1790mm(70.5")	-

◆ : Heavy duty bucket

◎ : Rock bucket(Heavy)

■ : Slope finishing bucket

9. RECOMMENDED OILS

Use only oils listed below or equivalent.
Do not mix different brand oil.

Service point	Kind of fluid	Capacity l (U.S. gal)	Ambient temperature °C (°F)								
			-20 (-4)	-10 (14)	0 (32)	10 (50)	20 (68)	30 (86)	40 (104)		
Engine oil pan	Engine oil	24(6.34)					SAE 30				
			SAE 10W								
			SAE 10W-30								
			SAE 15W-40								
Swing drive	Grease	1.2(0.3)	NLGI NO.1								
			NLGI NO.2								
Swing drive	Gear oil	5.0(1.3)	SAE 85W-140								
Final drive		5.8×2 (1.5×2)									
Hydraulic tank	Hydraulic oil	Tank; 180(48) System; 290(77)	ISO VG 32								
			ISO VG 46								
			ISO VG 68								
Fuel tank	Diesel fuel	340(89.8)	ASTM D975 NO.1								
			ASTM D975 NO.2								
Fitting (Grease nipple)	Grease	As required	NLGI NO.1								
			NLGI NO.2								
Radiator (Reservoir tank)	Mixture of antifreeze and water 50 : 50	35(9.2)	Ethylene glycol base permanent type								

SAE : Society of Automotive Engineers

API : American Petroleum Institute

ISO : International Organization for Standardization

NLGI : National Lubricating Grease Institute

ASTM : American Society of Testing and Material