

GROUP 5 COMBINED OPERATION

1. OUTLINE

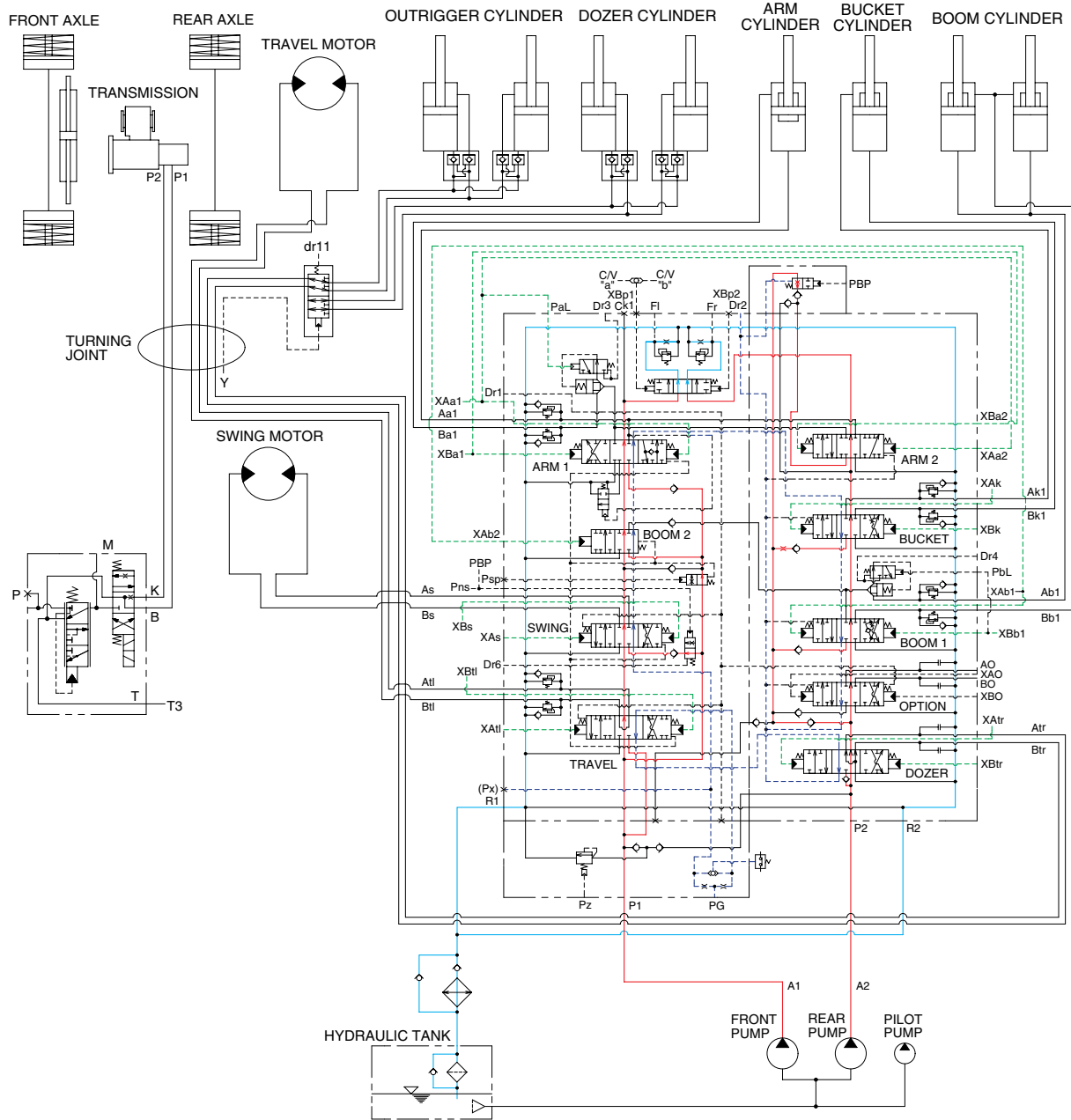

20W7A3HC23

The oil from the front and rear pump flows through the neutral oil passage, bypass oil passage and confluence oil passage in the main control valve. Then the oil goes to each actuator and operates them. Check valves and orifices are located on these oil passage in the main control valve. These control the oil from the main pumps so as to correspond to the operation of each actuator and smooth the combined operation.

2. COMBINED SWING AND BOOM OPERATION

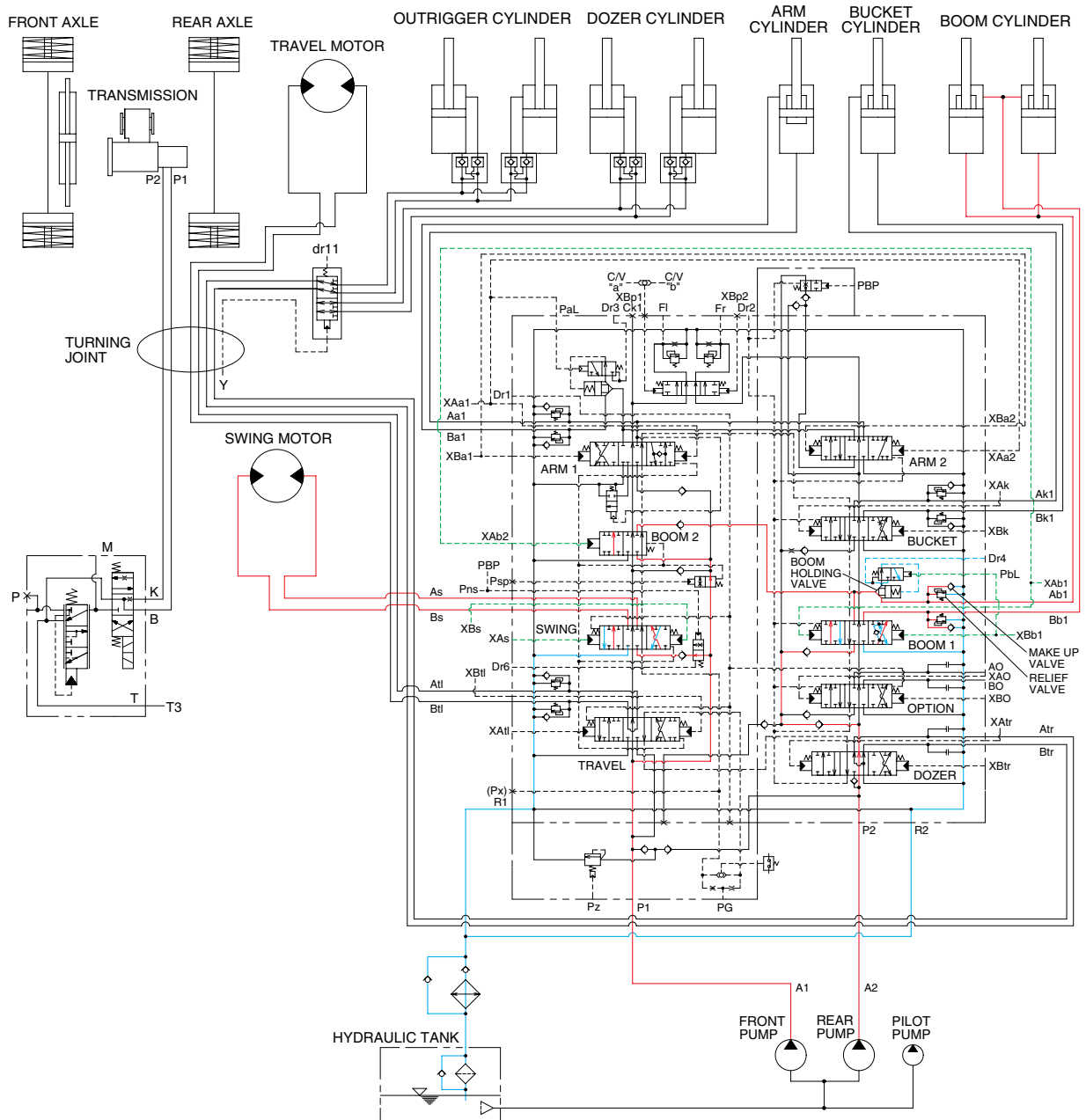

20W7A3HC24

When the swing and boom functions are operated, simultaneously the swing spool and boom spools in the main control valve are moved to the functional position by the pilot oil pressure from the remote control valve.

The oil from the front pump flows into the swing motor through swing spool and the boom cylinder through boom 2 spool.

The oil from the rear pump flows into the boom cylinders through the boom 1 spool in the right control valve.

The superstructure swings and the boom is operated.

3. COMBINED SWING AND ARM OPERATION

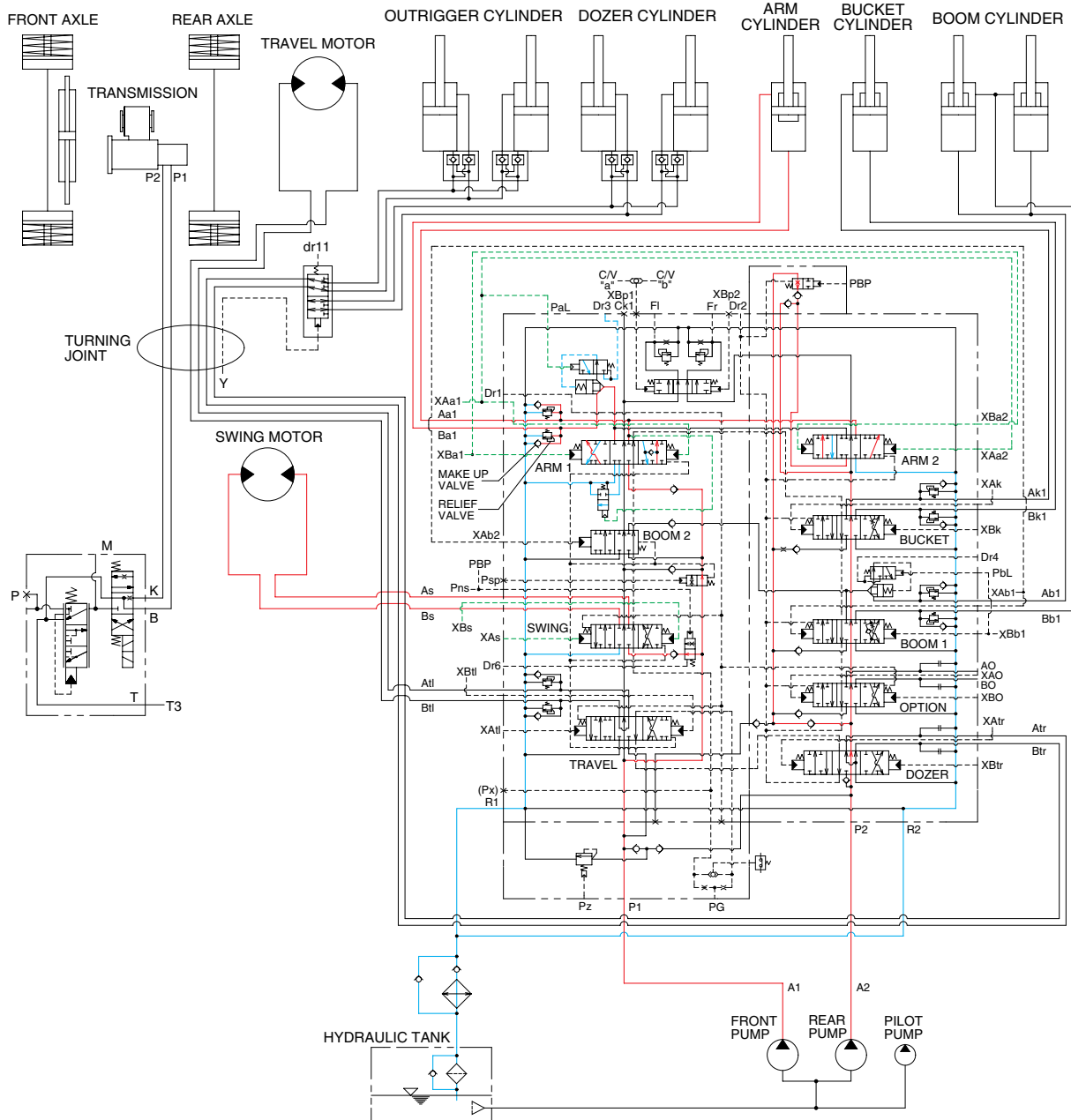

20W7A3HC25

When the swing and arm functions are operated, simultaneously the swing spool and arm spools in the main control valve are moved to the functional position by the pilot oil pressure from the remote control valve.

The oil from the front pump flows into the swing motor through swing spool and the arm cylinder through arm 1 spool.

The oil from the rear pump flows into the arm cylinder through the arm 2 spool of the right control valve.

The superstructure swings and the arm is operated.

4. COMBINED SWING AND BUCKET OPERATION

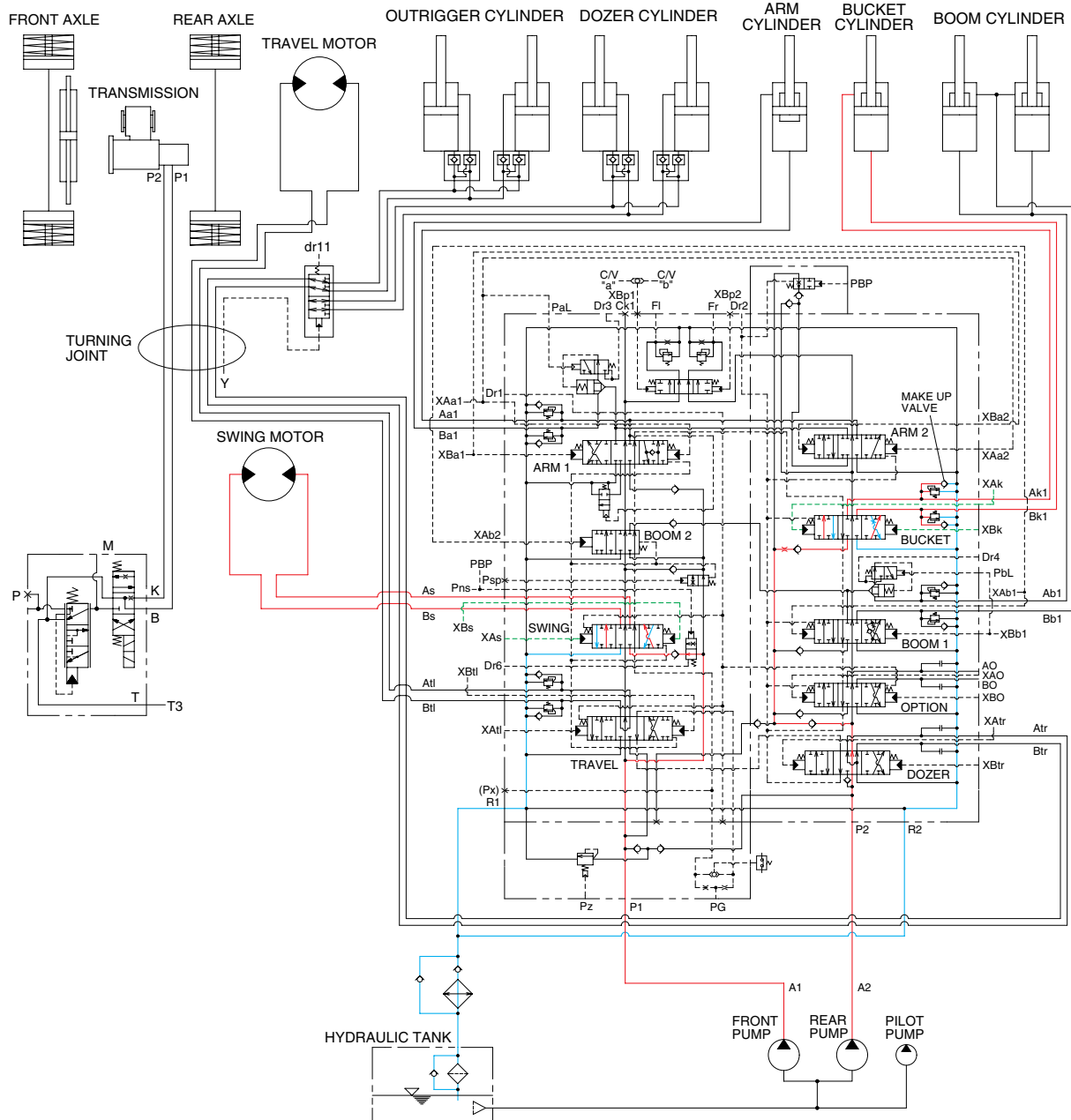

20W7A3HC26

When the swing and bucket functions are operated, simultaneously the swing spool and bucket spool in the main control valve are moved to the functional position by the pilot oil pressure from the remote control valve.

The oil from the front pump flows into the swing motor through the swing spool in the left control valve.

The oil from the rear pump flows into the bucket cylinder through the bucket spool in the right control valve.

The superstructure swings and the bucket is operated.

