

## SECTION 2 STRUCTURE AND FUNCTION

Group 1 Pump Device	2-1
Group 2 Main Control Valve	2-22
Group 3 Swing Device	2-53
Group 4 Travel Device	2-62
Group 5 RCV Lever	2-68
Group 6 Accelerator Pedal	2-75
Group 7 Brake Pedal	2-76
Group 8 Transmission	2-79
Group 9 Travel Control Valve	2-86
Group 10 Steering Valve	2-88
Group 11 Axle	2-90

# SECTION 2 STRUCTURE AND FUNCTION

## GROUP 1 PUMP DEVICE

### 1. STRUCTURE

The pump device consists of main pump, regulator and gear pump.

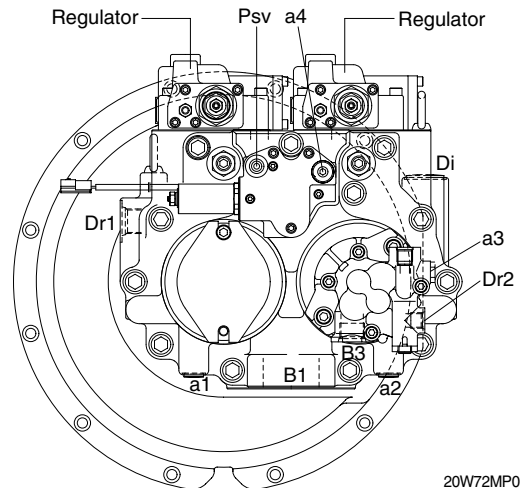
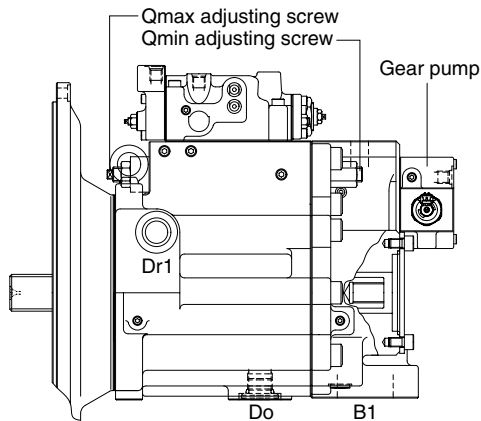
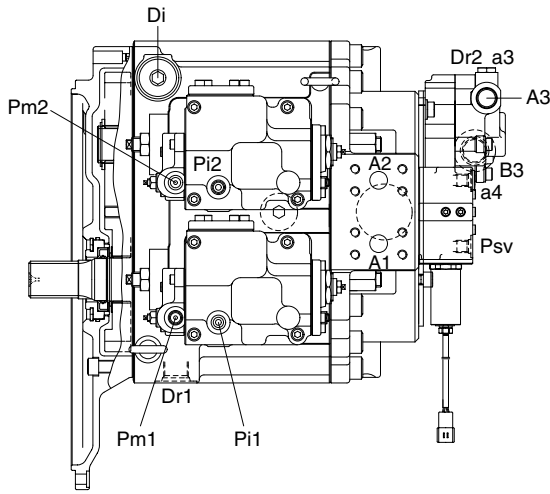

20W72MP01

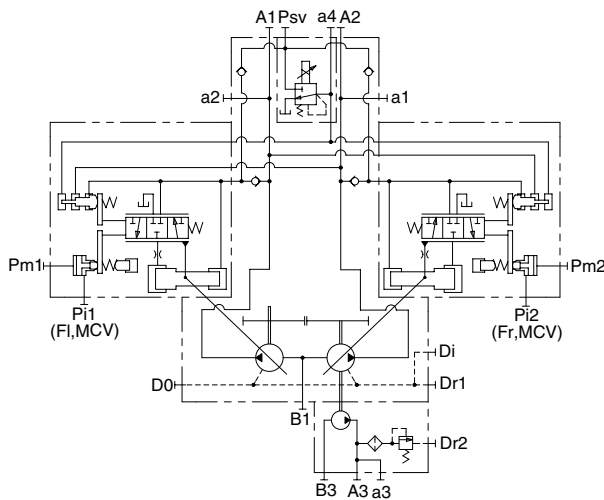

Port	Port name	Port size
A1,A2	Delivery port	SAE6000psi 3/4"
B1	Suction port	SAE2500psi 2 1/2"
Dr1	Drain port	PF 3/4 - 20
Pi1,Pi2	Pilot port	PF 1/4 - 15
Pm1,Pm2	Qmax cut port	PF 1/4 - 15
Psv	Servo assist port	PF 1/4 - 15
a1,2,4	Gauge port	PF 1/4 - 15
a3	Gauge port	PF 1/4 - 14
A3	Gear pump delivery port	PF 3/8 - 15
B3	Gear pump suction port	PF 3/4 - 20.5
Dr2	Gear pump drain port	PF 3/8 - 15
Di	Oil filling port	PF 3/4 - 20
Do	Outlet port	PF 3/4 - 20

# 1) MAIN PUMP(1/2)

The main pump consists of two piston pumps(front & rear) and valve block.

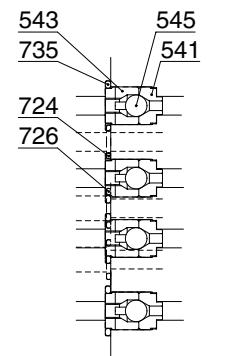
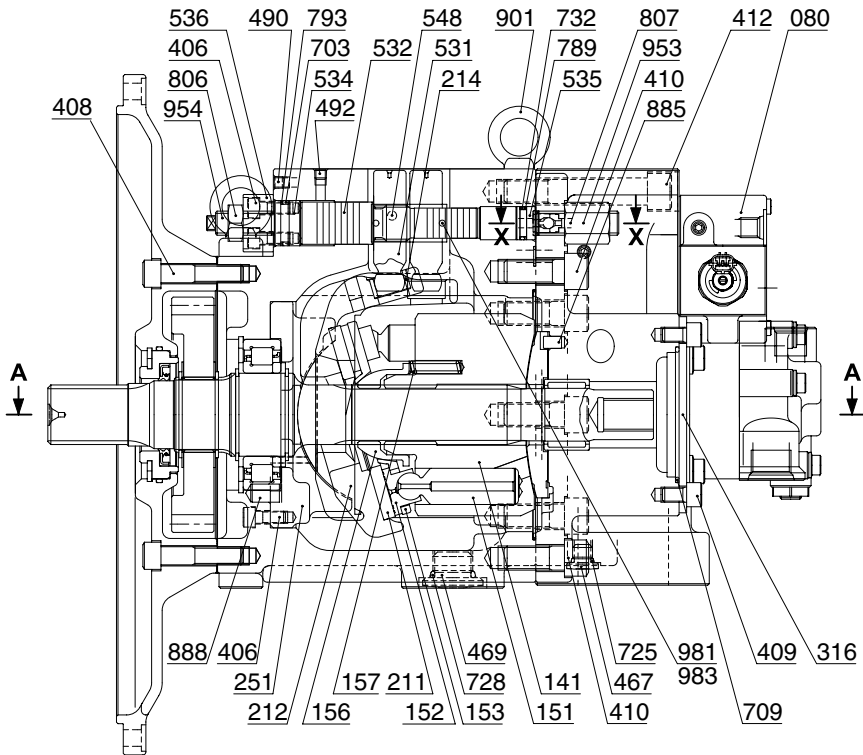

**SECTION X-X**

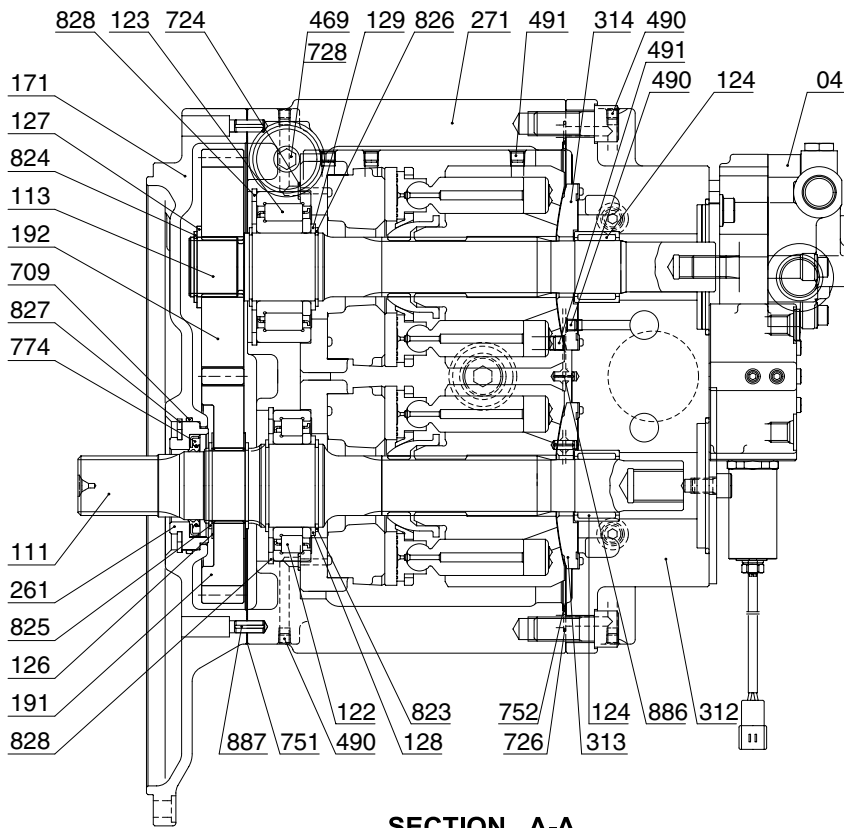

**SECTION A-A**

04	Gear pump	312	Valve cover	724	O-ring
080	Proportional reducing valve assy	313	Valve plate (R)	725	O-ring
111	Drive shaft	314	Valve plate (L)	726	O-ring
113	Driven shaft	316	Cover	728	O-ring
122	Roller bearing	406	Hexagon socket bolt	732	O-ring
123	Roller bearing	408	Hexagon socket bolt	735	O-ring
124	Needle bearing	409	Hexagon socket bolt	751	Packing
126	Bearing spacer	410	Hexagon socket bolt	752	Seat packing
127	Bearing spacer	412	Hexagon socket bolt	774	Oil seal
128	Bearing spacer	467	Plug	789	Back up ring
129	Bearing spacer	469	Plug	793	Back up ring
141	Cylinder block	490	Plug	806	Nut
151	Piston	491	Plug	807	Nut
152	Shoe	492	Restrictor	823	Snap ring
153	Set plate	531	Tilting pin	824	Snap ring
156	Bushing	532	Servo piston	825	Snap ring
157	Cylinder spring	534	Stopper (L)	827	Snap ring
171	Front casing	535	Stopper (S)	828	Snap ring
191	Drive gear	536	Servo cover	885	Valve plate pin
192	Driven gear	541	Seat	886	Spring pin
211	Shoe plate	543	Stopper	887	Spring pin
212	Swash plate	545	Steel ball	888	Pin
214	Tilting bushing	548	Feed back pin	901	Eye bolt
251	Swash plate support	703	O-ring	953	Set screw
261	Front cover	709	O-ring	954	Set screw
271	Pump casing	711	O-ring		
		712	O-ring		

**MAIN PUMP(2/2)**

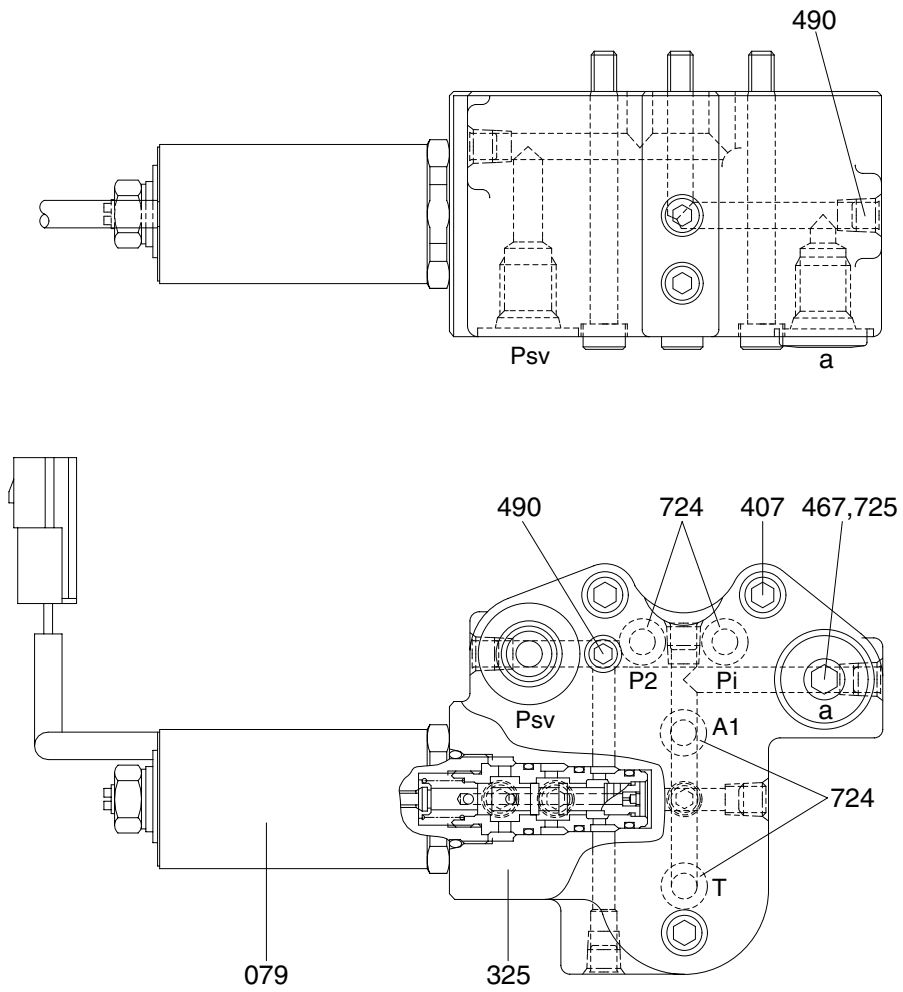

20W7A2MP03

- |     |                             |     |        |     |        |
|-----|-----------------------------|-----|--------|-----|--------|
| 079 | Proportional reducing valve | 467 | Plug   | 725 | O-ring |
| 325 | Valve casing                | 490 | Plug   |     |        |
| 407 | Hexagon socket screw        | 724 | O-ring |     |        |

## 2) REGULATOR(1/2)

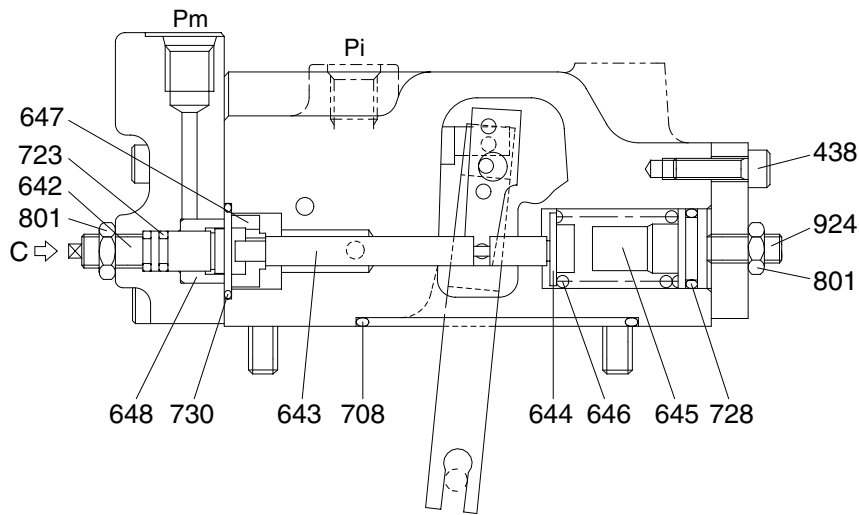
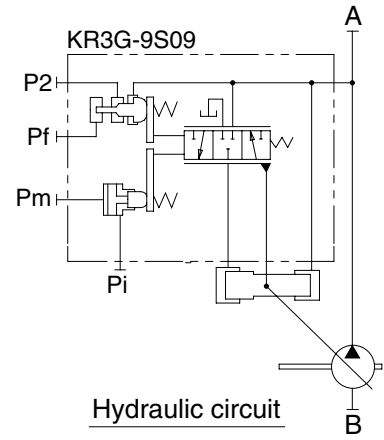
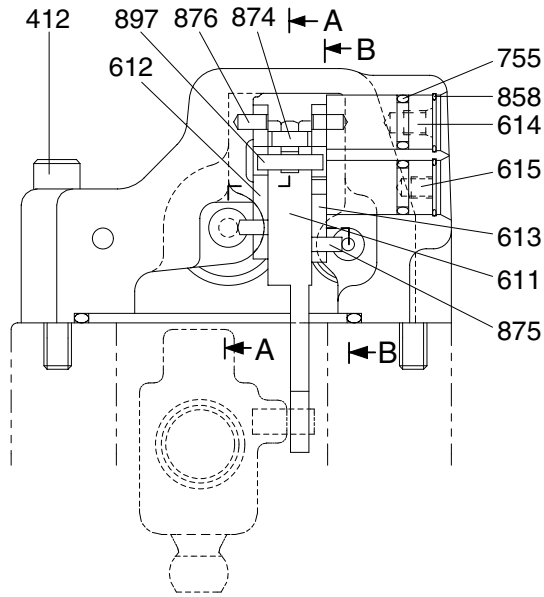

SECTION B-B

20W7A2MP04

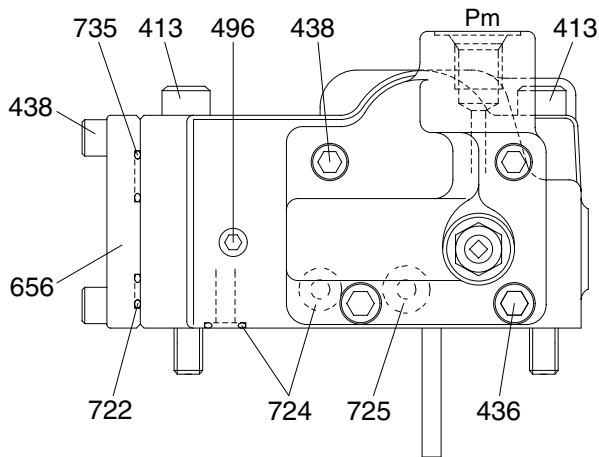

VIEW C

Port	Port name	port size
Pi	Pilot port	PF 1/4 - 15
Pm	Qmax cut port	PF 1/4 - 15

## REGULATOR(2/2)

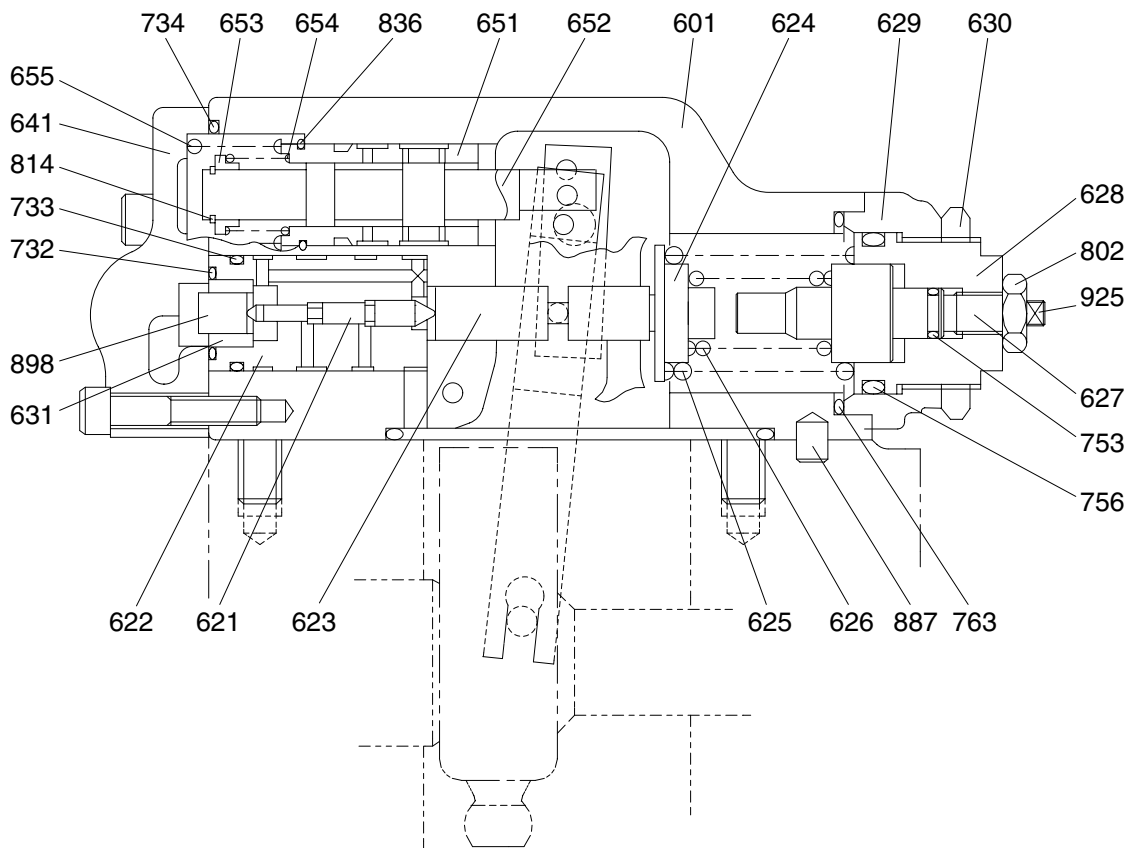

SECTION A-A

20W7A2MP05

412 Hexagon socket screw	631 Sleeve, PF	730 O-ring
413 Hexagon socket screw	641 Pilot cover	732 O-ring
436 Hexagon socket screw	642 Adjust screw (QMC)	733 O-ring
438 Hexagon socket screw	643 Pilot piston	734 O-ring
496 Plug	644 Spring seat (Q)	735 O-ring
601 Casing	645 Adjust stem (Q)	755 O-ring
611 Feed back lever	646 Pilot spring	756 O-ring
612 Lever (1)	647 Stopper	763 O-ring
613 Lever (2)	648 Piston (QMC)	801 Nut
614 Center plug	651 Sleeve	802 Nut
615 Adjust plug	652 Spool	814 Snap ring
621 Compensator piston	653 Spring seat	836 Snap ring
622 Piston case	654 Return spring	858 Snap ring
623 Compensator rod	655 Set spring	874 Pin
624 Spring seat (C)	656 Block cover	875 Pin
625 Outer spring	708 O-ring	876 Pin
626 Inner spring	722 O-ring	887 Pin
627 Adjust stem (C)	723 O-ring	897 Pin
628 Adjust screw (C)	724 O-ring	898 Pin
629 Cover (C)	725 O-ring	924 Set screw
630 Lock nut	728 O-ring	

### 3) GEAR PUMP

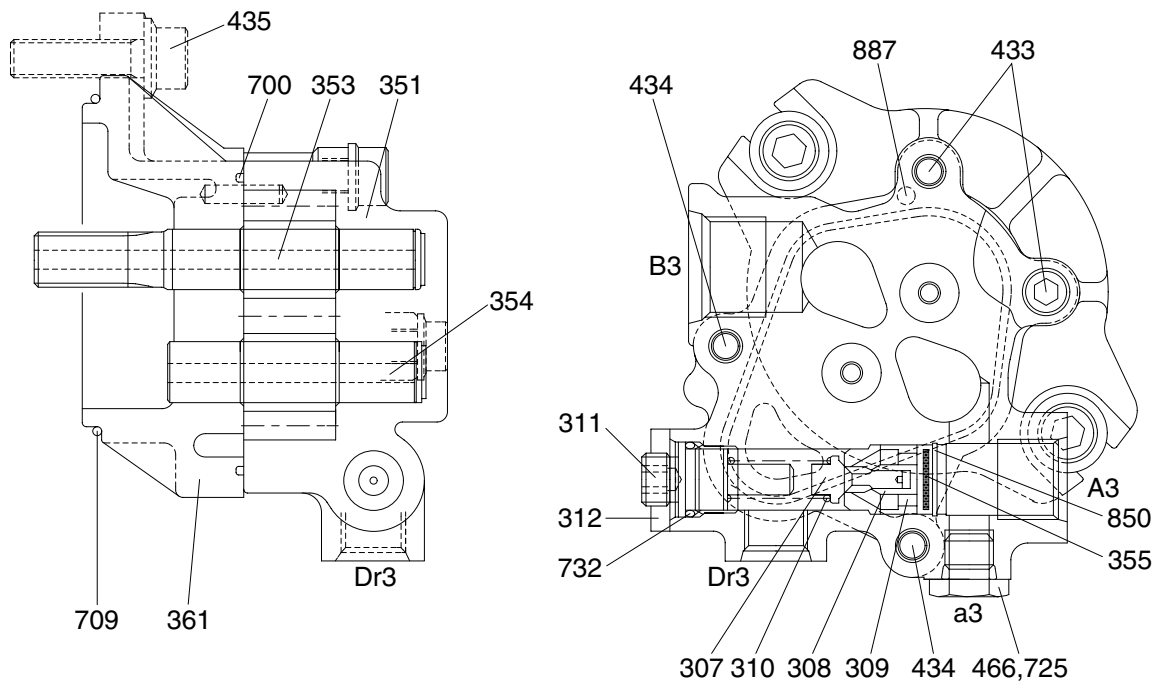

14W7A2MP06

307	Poppet	353	Drive gear	466	Plug
308	Seat	354	Driven gear	700	Ring
309	Ring	355	Filter	709	O-ring
310	Spring	361	Front case	725	O-ring
311	Adjusting screw	433	Flange socket	732	O-ring
312	Lock nut	434	Flange socket	850	Snap ring
351	Gear case	435	Flange socket	887	Pin

## 2. FUNCTION

### 1) MAIN PUMP

The pumps may be classified roughly into the rotary group performing a rotary motion and working as the major part of the whole pump function: the swash plate group that varies the delivery rates: and the valve cover group that changes over oil suction and discharge.

#### (1) Rotary group

The rotary group consists of drive shaft (F) (111), cylinder block (141), piston shoes (151,152), set plate (153), spherical bushing (156) and cylinder spring (157).

The drive shaft is supported by bearings (122,124) at its both ends.

The shoe is caulked to the piston to form a spherical coupling. It has a pocket to relieve thrust force generated by loading pressure and to take hydraulic balance so that it slides lightly over the shoe plate (211). The sub group composed by a piston and a shoe is pressed against the shoe plate by the action of the cylinder spring via a retainer and a spherical bush.

Similarly, the cylinder block is pressed against valve plate (313) by the action of the cylinder spring.

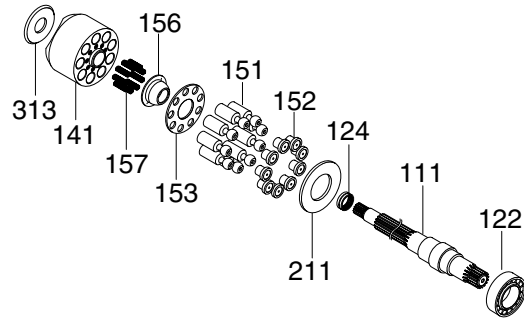

210N72MP04

#### (2) Swash plate group

The swash plate group consists of swash plate (212), shoe plate (211), swash plate support (251), tilting bushing (214), tilting pin (531) and servo piston (532).

The swash plate is a cylindrical part formed on the opposite side of the sliding surface of the shoe and is supported by the swash support.

If the servo piston moves to the right and left as hydraulic force controlled by the regulator is admitted to hydraulic chamber located on both sides of the servo piston, the swash plate slides over the swash plate support via the spherical part of the tilting pin to change the tilting angle ( $\alpha$ )

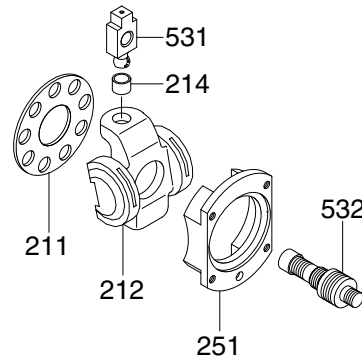

210N72MP05

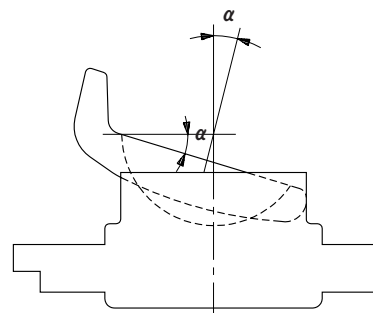

2-7 (210-7)

### (3) Valve cover group

The valve cover group consists of valve cover (312), valve plates (313, 314) and valve plate pin (885).

The valve plate having two melon-shaped ports is fixed to the valve cover and feeds and collects oil to and from the cylinder block.

The oil changed over by the valve plate is connected to an external pipeline by way of the valve cover.

Now, if the drive shaft is driven by a prime mover (electric motor, engine, etc), it rotates the cylinder block via a spline linkage at the same time. If the swash plate is tilted as in Fig (previous page) the pistons arranged in the cylinder block make a reciprocating motion with respect to the cylinder block, while they revolve with the cylinder block.

If you pay attention to a single piston, it performs a motion away from the valve plate (oil sucking process) within 180 degrees, and makes a motion towards the valve plate (or oil discharging process) in the rest of 180 degrees. When the swash plate has a tilting angle of zero, the piston makes no stroke and discharges no oil.

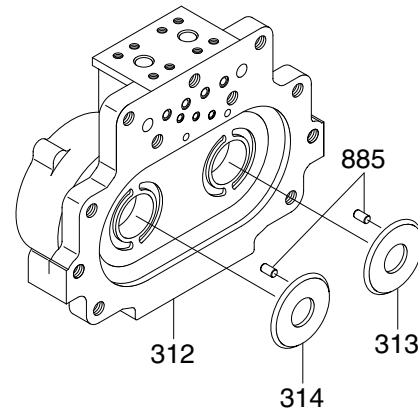

210N72MP06

## 2) REGULATOR

Regulator consists of the negative flow control, total horsepower control and power shift control function.

### (1) Negative flow control

By changing the pilot pressure  $P_i$ , the pump tilting angle (delivery flow) is regulated arbitrarily, as shown in the figure.

This regulator is of the negative flow control in which the delivery flow  $Q$  decreases as the pilot pressure  $P_i$  rises.

With this mechanism, when the pilot pressure corresponding to the flow required for the work is commanded, the pump discharges the required flow only, and so it does not consume the power uselessly.

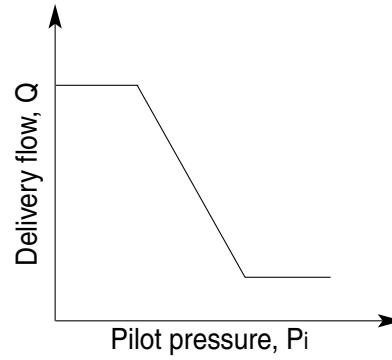

## ① Flow reducing function

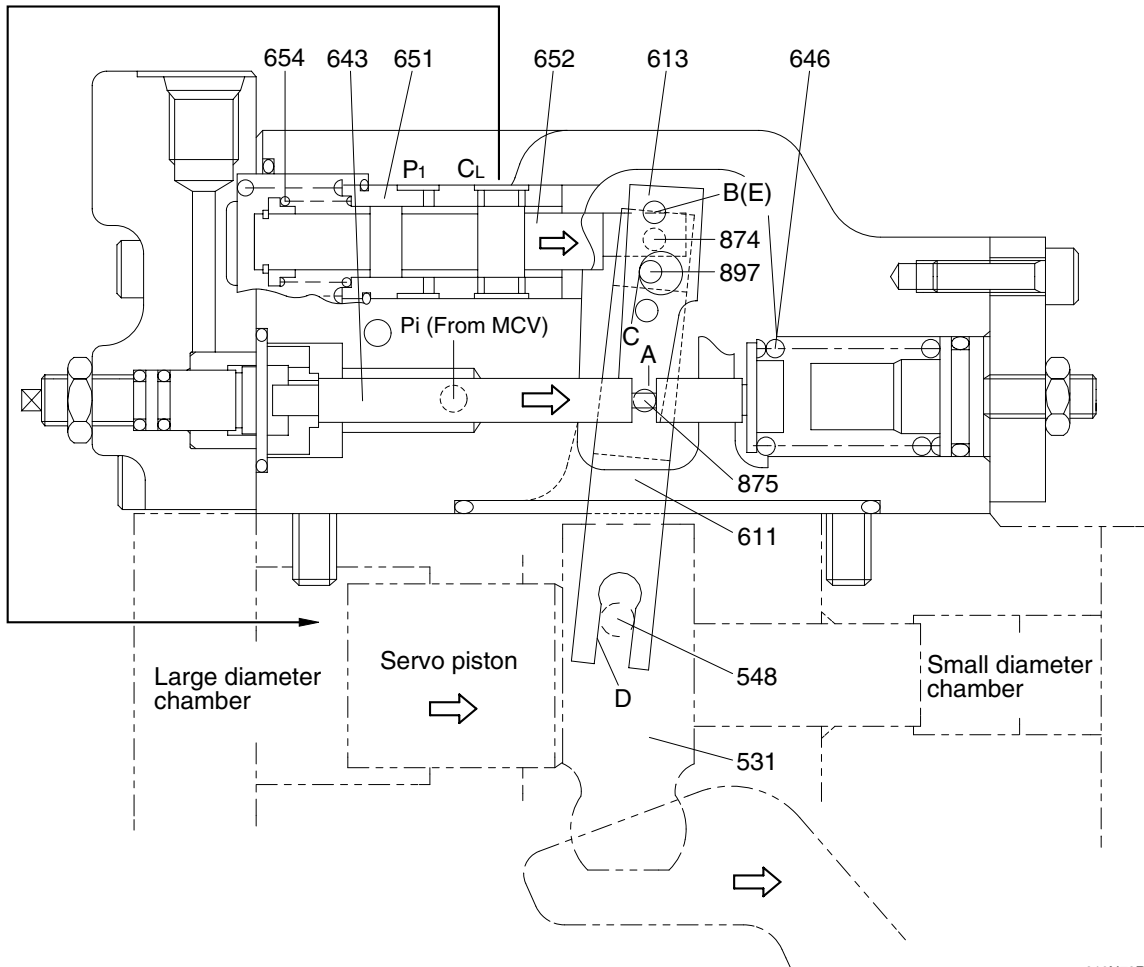

210N72RG07

As the pilot pressure  $P_i$  rises, the pilot piston (643) moves to the right to a position where the force of the pilot spring (646) balances with the hydraulic force.

The groove (A) in the pilot piston is fitted with the pin (875) that is fixed to lever 2 (613). Therefore, when the pilot piston moves, lever 2 rotates around the fulcrum of point B [Fixed by the fulcrum plug (614) and pin (875)]. Since the large hole section (C) of lever 2 contains a protruding pin (897) fixed to the feedback lever (611), the pin (897) moves to the right as lever 2 rotates. Since the opposing-flat section (D) of the feedback lever is fitted with the pin (548) fixed by the tilting pin (531) that swings the swash plate, the feedback lever rotates around the fulcrum of point D, as the pin (897) moves.

Since the feedback lever is connected with the spool (652) via the pin (874), the spool moves to the right.

The movement of the spool causes the delivery pressure  $P_1$  to connect to port CL through the spool and to be admitted to the large diameter section of the servo piston. The delivery pressure  $P_1$  that is constantly admitted to the small diameter section of the servo piston moves the servo piston to the right due to the area difference, resulting in decrease of the tilting angle.

When the servo piston moves to the right, point D also moves to the right. The spool is fitted with the return spring (654) and is tensioned to the left at all times, and so the pin (897) is pressed against the large hole section (C) of lever 2.

Therefore, as point D moves, the feedback lever rotates around the fulcrum of point C, and the spool is shifted to the left. This causes the opening between the sleeve (651) and spool (652) to close slowly, and the servo piston comes to a complete stop when it closes completely.

② Flow increasing function

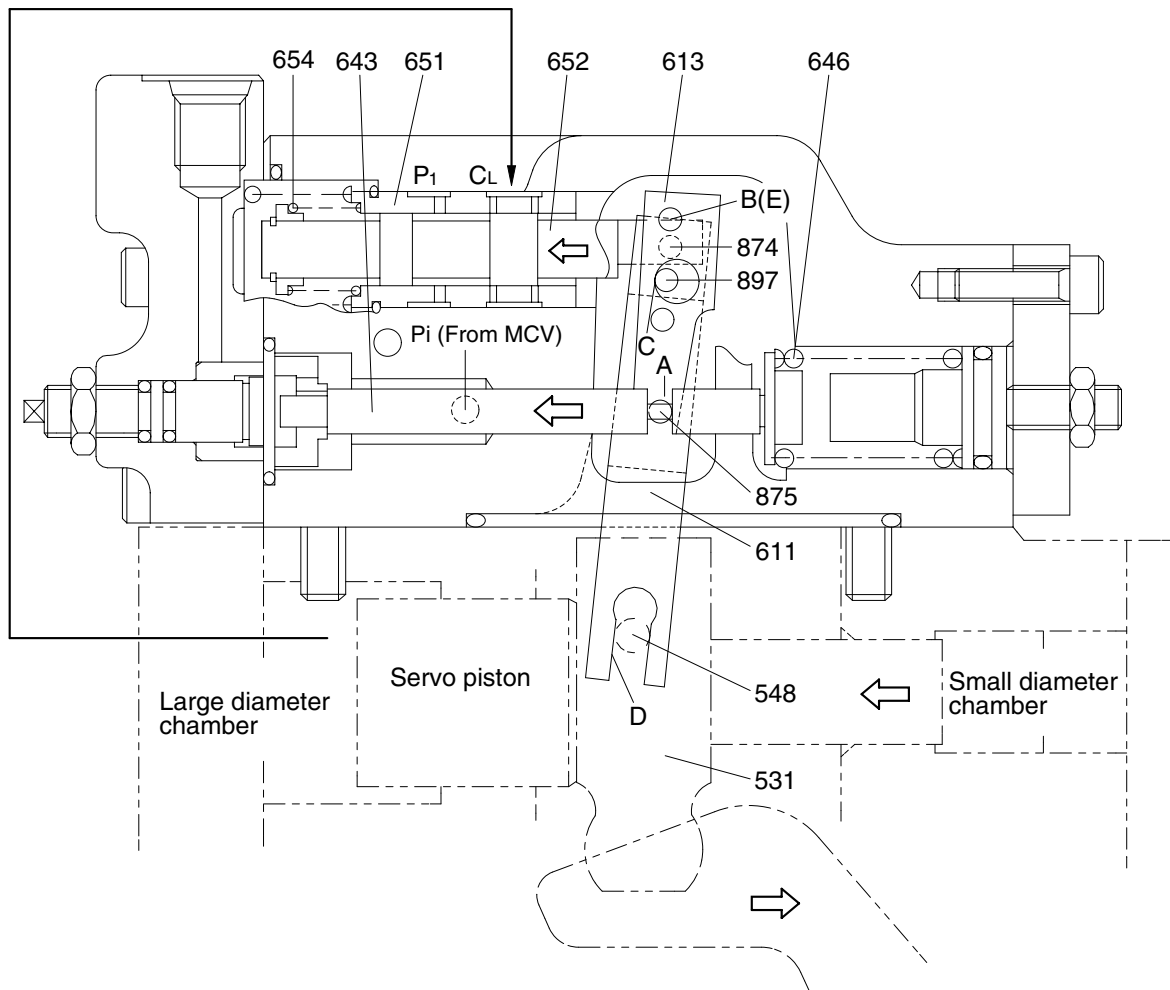

210N72RG08

As the pilot pressure  $P_i$  decreases, the pilot piston (643) moves to the left by the action of the pilot spring (646) and causes lever 2 (613) to rotate around the fulcrum of point B. Since the pin (897) is pressed against the large hole section (C) of lever 2 by the action of the return spring (654) via the spool (652), pin (874), and feedback lever (611), the feedback lever rotates around the fulcrum of point D as lever 2 rotates, and shifts the spool to the left. Port CL opens a way to the tank port as the spool moves. This deprives the large diameter section of the servo piston of pressure, and shifts the servo piston to the left by the discharge pressure  $P_1$  in the small diameter section, resulting in an increase in the flow rate.

As the servo piston moves, point D also moves to the left, the feedback lever rotates around the fulcrum of point C, and the spool moves to the right till the opening between the spool and sleeve is closed.

### ③ Adjustment of flow control characteristic

The flow control characteristic can be adjusted with the adjusting screw.

Adjust it by loosening the hexagon nut (801) and by tightening (or loosening) the hexagonal socket head screw (924).

Tightening the screw shifts the control chart to the right as shown in the figure.

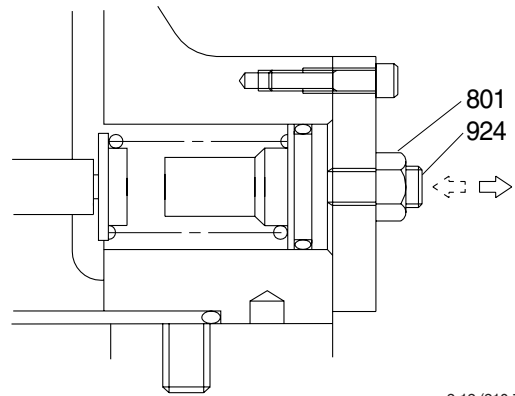

2-12 (210-7)

※ Adjusting values are shown in table.

Speed	Adjustment of flow control characteristic		
	Tightening amount of adjusting screw (924)	Flow control starting pressure change amount	Flow change amount
(min <sup>-1</sup> )	(Turn)	(kgf/cm <sup>2</sup> )	( l /min)
1900	+1/4	+1.5	+12.3

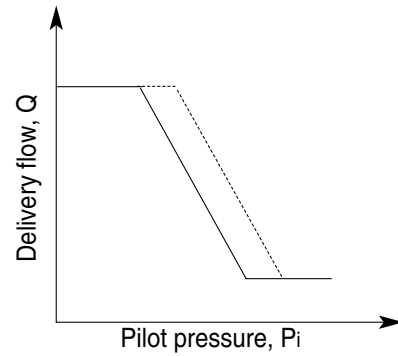

## (2) Total horsepower control

The regulator decreases the pump tilting angle (delivery flow) automatically to limit the input torque within a certain value with a rise in the delivery pressure  $P_1$  of the self pump and the delivery pressure  $P_2$  of the companion pump.

(The input horsepower is constant when the speed is constant.)

Since the regulator is of the simultaneous total horsepower type that operates by the sum of load pressures of the two pumps in the tandem double-pump system, the prime mover is automatically prevented from being overloaded, irrespective of the load condition of the two pumps, when horsepower control is under way.

Since this regulator is of the simultaneous total horsepower type, it controls the tilting angles (displacement volumes) of the two pumps to the same value as represented by the following equation :

$$\begin{aligned} T_{in} &= P_1 \times q/2\pi + P_2 \times q/2\pi \\ &= (P_1+P_2) \times q/2\pi \end{aligned}$$

The horsepower control function is the same as the flow control function and is summarized in the following. (For detailed behaviors of respective parts, refer to the section of flow control).

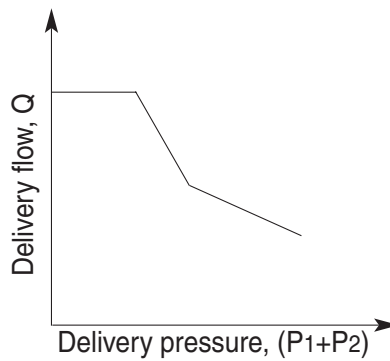

## ① Overload preventive function

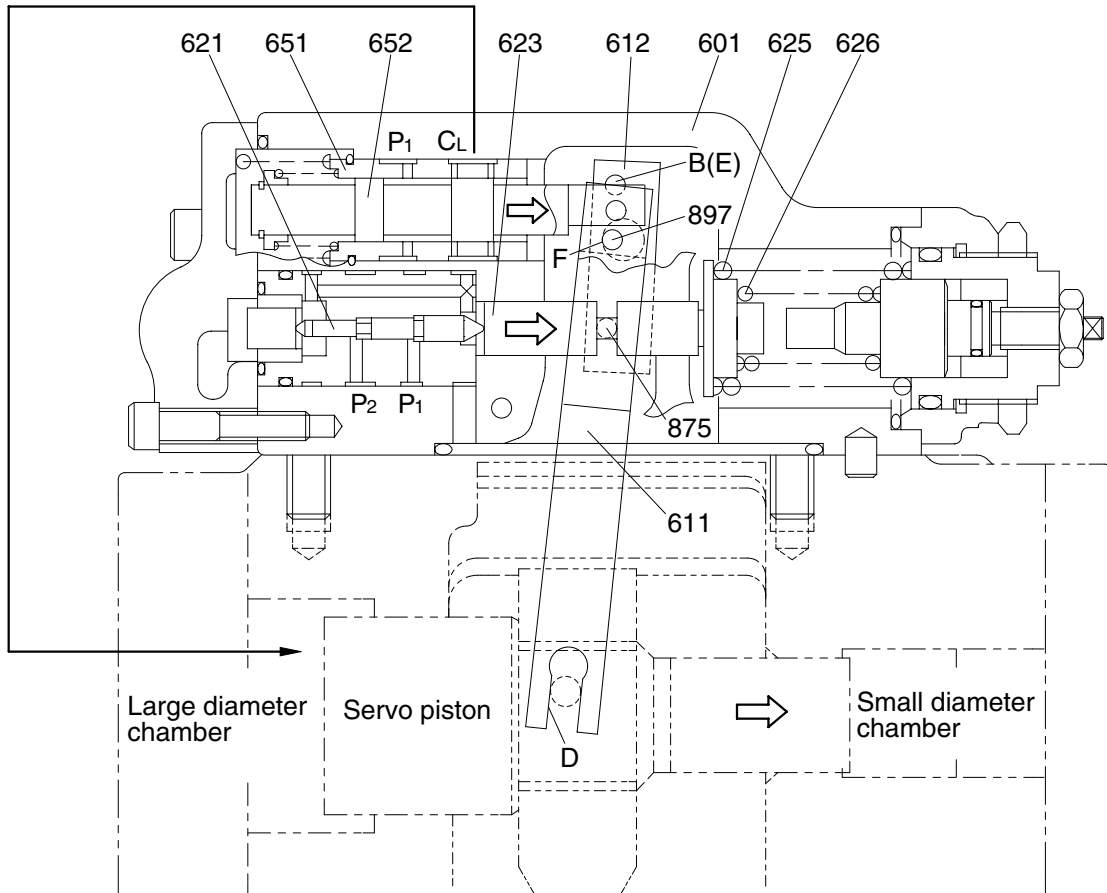

20W7A2RG03

When the self pump delivery pressure  $P_1$  or the companion pump delivery pressure  $P_2$  rises, it acts on the stepped part of the compensating piston (621). It presses the compensating rod (623) to the right till the force of the outer spring (625) and inner spring (626) balances with the hydraulic force. The movement of the compensating rod is transmitted to lever 1 (612) via pin (875).

Lever 1 rotates around the pin (875) (E) fixed to the casing (601).

Since the large hole section (F) of lever 1 contains a protruding pin (897) fixed to the feedback lever (611), the feedback lever rotates around the fulcrum of point D as lever 1 rotates, and then the spool (652) is shifted to the right. As the spool moves, the delivery pressure  $P_1$  is admitted to the large diameter section of the servo piston via port CL, causes the servo piston move to the right, reduces the pump delivery, flow rate, and prevents the prime mover from being overloaded.

The movement of the servo piston is transmitted to the feedback lever via point D. Then the feedback lever rotates around the fulcrum of point F and the spool is shifted to the left. The spool moves till the opening between the spool (652) and sleeve (651) is closed.

## ② Flow reset function

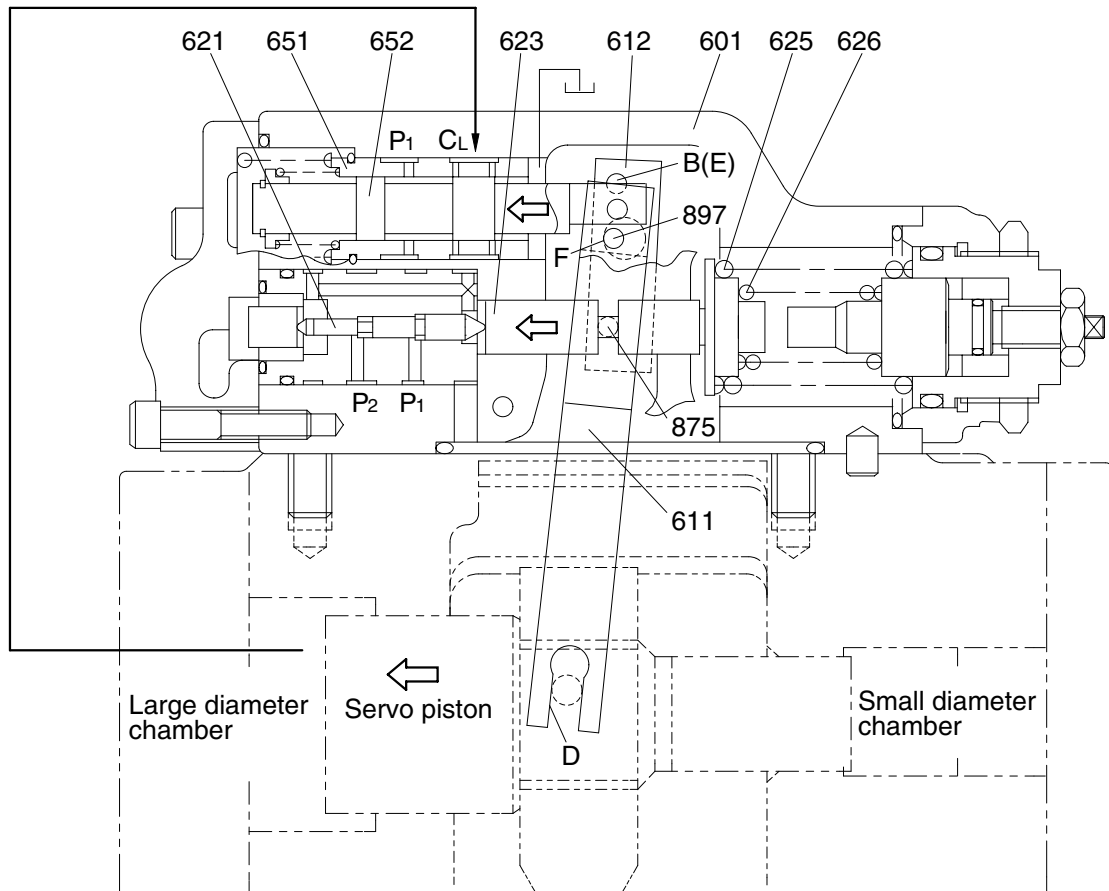

20W7A2RG04

As the self pump delivery pressure  $P_1$  or the companion pump delivery pressure  $P_2$  decreases, the compensating rod (623) is pushed back by the action of the springs (625 & 626) to rotate lever 1 (612) around point E. Rotating of lever 1 causes the feedback lever (611) to rotate around the fulcrum of point D and then the spool (652) to move to the left. As a result, port CL opens a way to the tank port.

This causes the servo piston to move to the left and the pump's delivery rate to increase.

The movement of the servo piston is transmitted to the spool by the action of the feedback mechanism to move it till the opening between the spool and sleeve is closed.

③ **Low tilting angle (low flow) command preferential function**

As mentioned above, flow control and horsepower control tilting angle commands are transmitted to the feedback lever and spool via the large-hole sections (C & F) of levers 1 and 2. However, since sections C and F have the pins ( $\varnothing 4$ ) protruding from the large hole ( $\varnothing 8$ ), only the lever lessening the tilting angle contacts the pin (897); the hole ( $\varnothing 8$ ) in the lever of a larger tilting angle command is freed without contacting the pin (897). Such a mechanical selection method permits preference of the lower tilting angle command of the flow control and horsepower control.

④ **Adjustment of input horsepower**

Since the regulator is of total cumulative horsepower type, adjust the adjusting screws of both the front and rear pumps, when changing the horsepower set values. The pressure change values by adjustment are based on two pumps pressurized at the same time, and the values will be doubled when only one pump is loaded.

a. **Adjustment of outer spring**

Adjust it by loosening the hexagon nut (630) and by tightening (or loosening) the adjusting screw C (628).

Tightening the screw shifts the control chart to the right and increases the input horsepower as shown in the figure. Since turning the adjusting screw C by N turns changes the setting of the outer spring (625), return the adjusting screw C (627) by  $N \times A$  turns at first. ( $A=1.48$ )

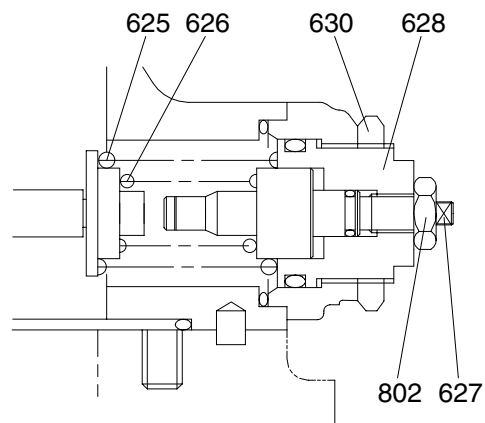

2107A2MP07A

※ **Adjusting values are shown in table.**

Speed	Adjustment of outer spring		
	Tightening amount of adjusting screw(C) (628)	Compensating control starting pressure change amount	Input torque change amount
(min <sup>-1</sup> )	(Turn)	(kgf/cm <sup>2</sup> )	(kgf · m)
1900	+1/4	+15.9	+4.0

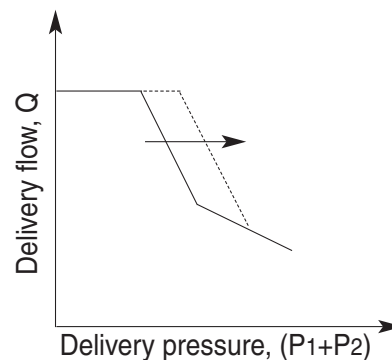

**b. Adjustment of inner spring**

Adjust it by loosening the hexagon nut (802) and by tightening (or loosening) the adjusting screw C (627).

Tightening the screw increases the flow and then the input horsepower as shown in the figure.

※ **Adjusting valves are shown in table.**

Speed	Adjustment of inner spring		
	Tightening amount of adjusting screw(C) (627)	Flow change amount	Input torque change amount
(min <sup>-1</sup> )	(Turn)	(kgf/cm <sup>2</sup> )	(kgf · m)
1900	+1/4	+11.3	+4.6

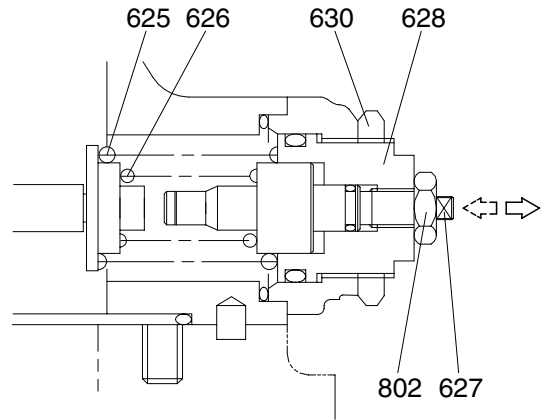

2107A2MP08

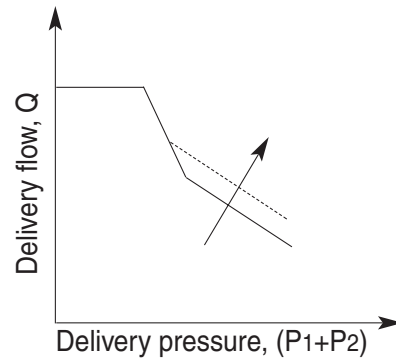

### (3) Power shift control

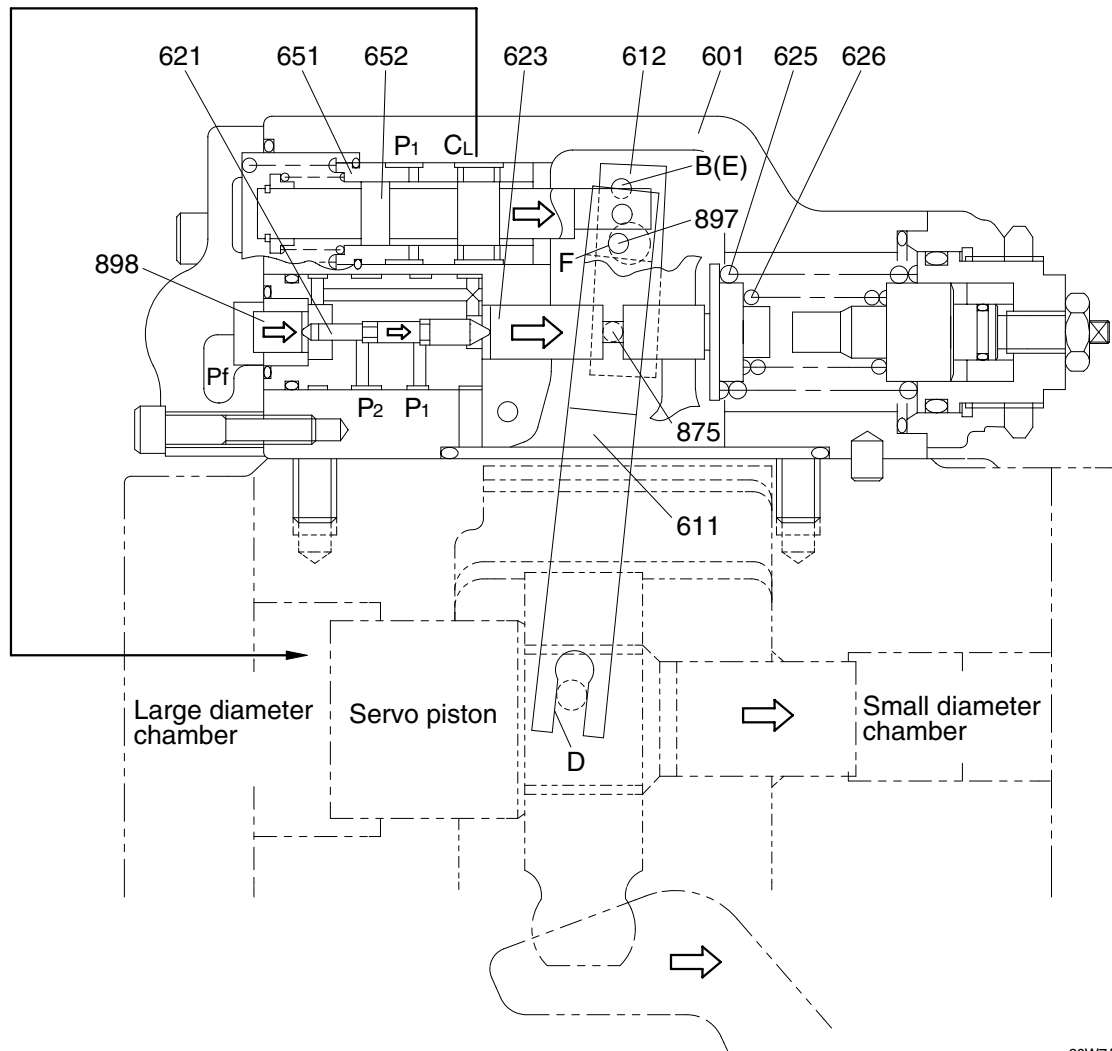

20W7A2RG05

The set horsepower valve is shifted by varying the command current level of the proportional pressure reducing valve attached to the pump. Only one proportional pressure reducing valve is provided. However, the secondary pressure Pf (power shift pressure) is admitted to the horsepower control section of each pump regulator through the pump's internal path to shift it to the same set horsepower level.

This function permits arbitrary setting of the pump output power, thereby providing the optimum power level according to the operating condition. The power shift pressure Pf controls the set horsepower of the pump to a desired level, as shown in the figure.

As the power shift pressure Pf rises, the compensating rod (623) moves to the right via the pin (898) and compensating piston (621).

This decreases the pump tilting angle and then the set horsepower in the same way as explained in the overload preventive function of the horsepower control. On the contrary, the set horsepower rises as the power shift pressure Pf falls.

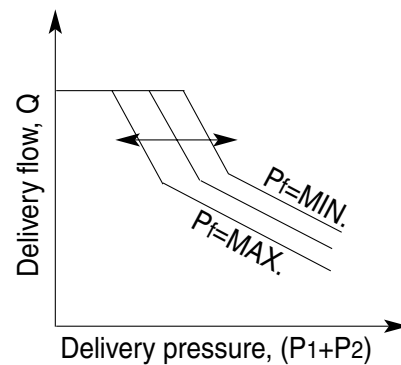

#### (4) Adjustment of maximum and minimum flows

##### ① Adjustment of maximum flow

Adjust it by loosening the hexagon nut (808) and by tightening (or loosening) the set screw (954).

The maximum flow only is adjusted without changing other control characteristics.

Speed	Adjustment of max flow	
	Tightening amount of adjusting screw (954)	Flow change amount
(min <sup>-1</sup> )	(Turn)	( l /min)
1900	+1/4	-5.5

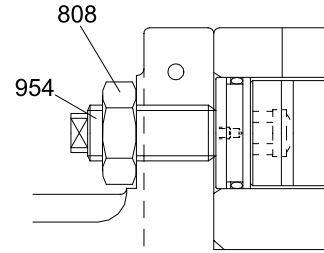

2507A2MP10

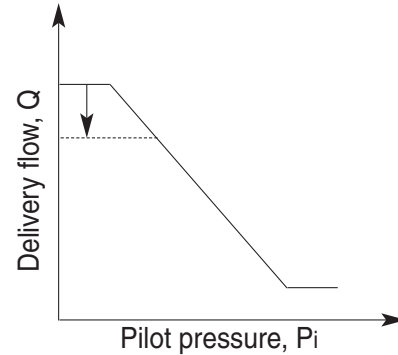

##### ② Adjustment of minimum flow

Adjust it by loosening the hexagon nut (806) and by tightening (or loosening) the hexagonal socket head set screw (953). Similarly to the adjustment of the maximum flow, other characteristics are not changed.

However, remember that, if tightened too much, the required horsepower during the maximum delivery pressure (or during relieving) may increase.

Speed	Adjustment of min flow	
	Tightening amount of adjusting screw (953)	Flow change amount
(min <sup>-1</sup> )	(Turn)	( l /min)
1900	+1/4	+4.4

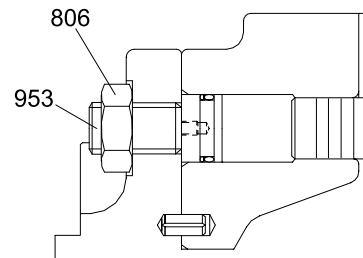

2507A2MP09

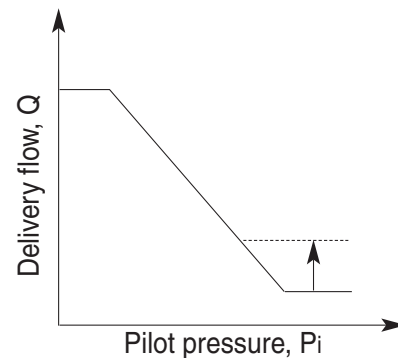

## (5) Qmax cut control

The regulator regulates the maximum delivery flow by inputting the pilot pressure  $P_m$ . Since this is a 2-position control method, the maximum delivery flow may be switched in two steps by turning on/off the pilot pressure  $P_m$ . (The maximum control flow cannot be controlled in intermediate level.)

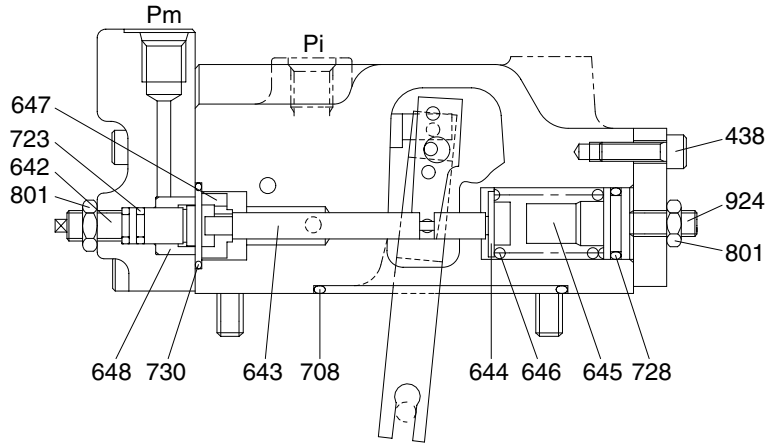

20W7A2MP20

### ① Functional explanation

As shown in the figure, the pilot pressure  $P_m$  switches the maximum flow in two steps.

When the pilot pressure  $P_m$  is given, it is admitted to the lefthand side of the piston QMC (648). The piston QMC moves the stopper (647) and pilot piston (643) to the right, overcoming the force of the pilot spring (646), thereby reducing the delivery flow of the pump.

Since the adjusting screw QMC (642) is provided with a flange, the piston QMC stops upon contact with the flange, and the position of the pilot piston at this time determines the maximum flow of the pump.

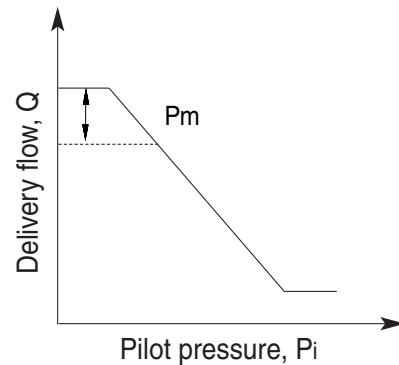

### ② Adjustment of Qmax cut flow

Adjust it by loosening the hexagon nut (801) and by tightening (or loosening) the adjusting screw QMC (642).

Tightening the screw decreases the Qmax cut flow as shown in the figure.

