

GROUP 7 WORK EQUIPMENT

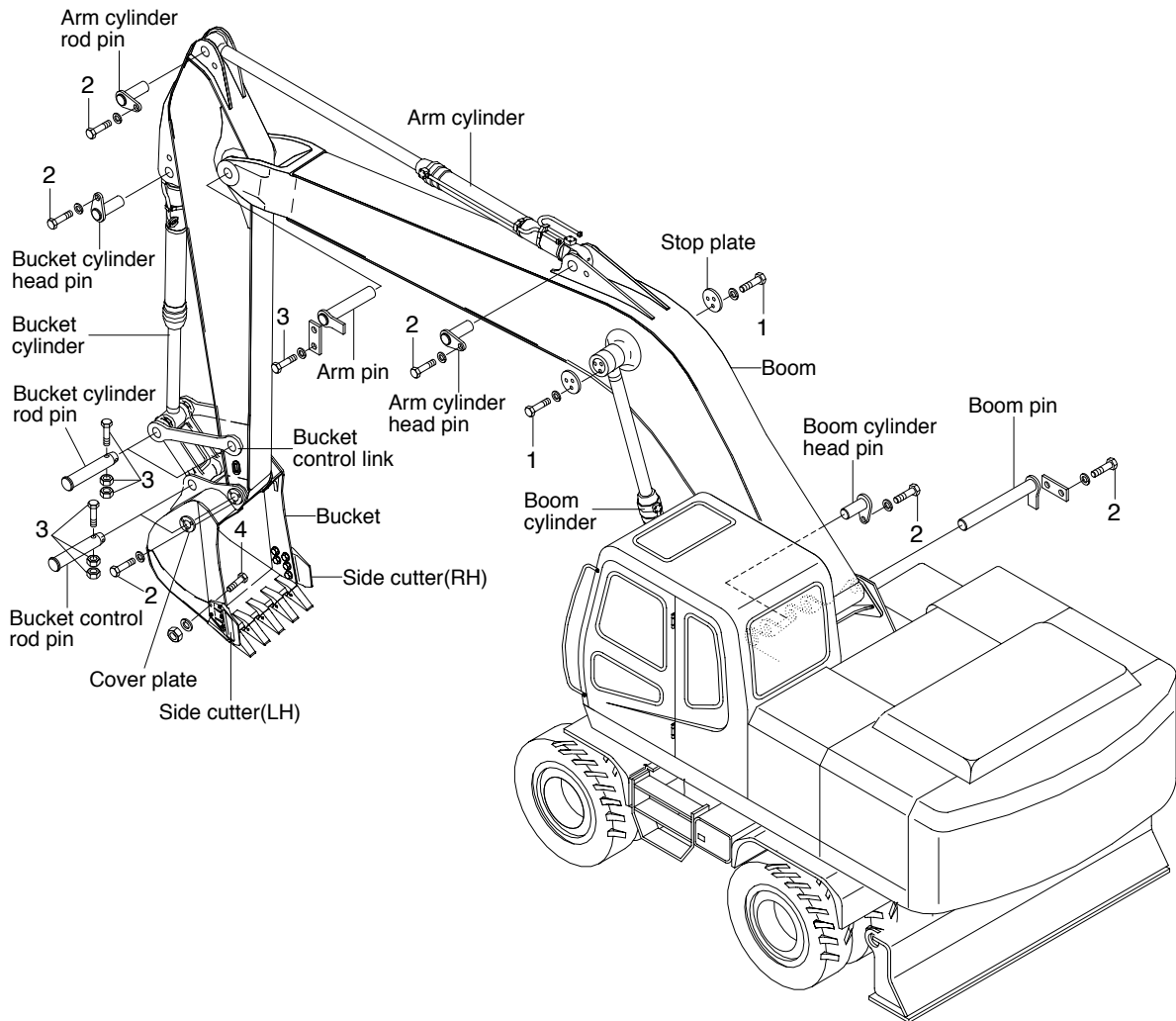

20W79CM13

· Tightening torque

Item	Size	kgf · m	lbf · ft
1	M12 × 1.75	12.8 ± 3.0	92.6 ± 21.7
2	M16 × 2.0	29.7 ± 4.5	215 ± 32.5

Item	Size	kgf · m	lbf · ft
3	M20 × 2.5	57.9 ± 8.7	419 ± 62.9
4	M22 × 2.5	55.8 ± 7.5	404 ± 54.2