

## GROUP 3 PUMP DEVICE

### 1. REMOVAL AND INSTALL

#### 1) REMOVAL

- (1) Lower the work equipment to the ground and stop the engine.
- (2) Operate the control levers and pedals several times to release the remaining pressure in the hydraulic piping.
- (3) Loosen the breather slowly to release the pressure inside the hydraulic tank.
- ▲ Escaping fluid under pressure can penetrate the skin causing serious injury.
- (4) Loosen the drain plug under the hydraulic tank and drain the oil from the hydraulic tank.
  - Hydraulic tank quantity : 180
- (5) Remove socket bolts(13) and disconnect pipe (1,2).
- (6) Disconnect pilot line hoses(4, 5, 6, 7, 8, 9, 10, 11).

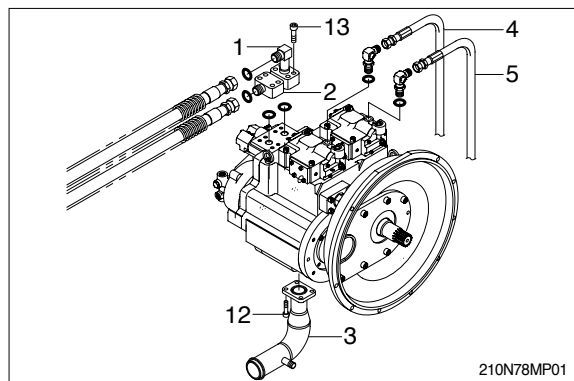

- (7) Remove socket bolts(12) and disconnect pump suction pipe (3).  
When pump suction pipe is disconnected, the oil inside the piping will flow out, so catch it in oil pan.
- (8) Sling the pump assembly and remove the pump mounting bolts.
  - Weight : 170kg(370lb)Pull out the pump assembly from housing. When removing the pump assembly, check that all the hoses have been disconnected.

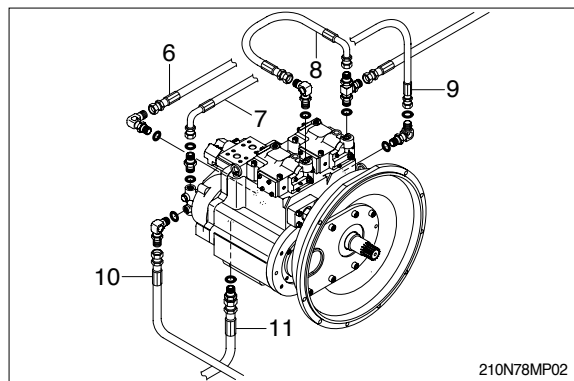

## 2) INSTALL

- (1) Carry out installation in the reverse order to removal
- (2) Remove the suction strainer and clean it.
- (3) Replace the return filter with a new one.
- (4) Remove breather and clean it.
- (5) After adding oil to the hydraulic tank to the specified level.
- (6) Bleed the air from the hydraulic pump.  
Remove the air vent plug(2EA)  
Tighten plug lightly  
Start the engine, run at low idling, and check oil come out from plug.  
Tighten plug.
- (7) Start the engine, run at low idling(3~5 minutes) to circulate the oil through the system.
- (8) Confirmed the hydraulic oil level and check the hydraulic oil leaks or not.

## 2. MAIN PUMP(1/2)

### 1) STRUCTURE

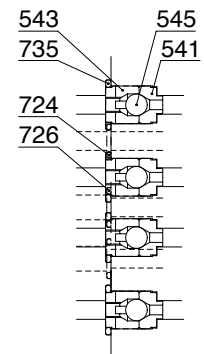
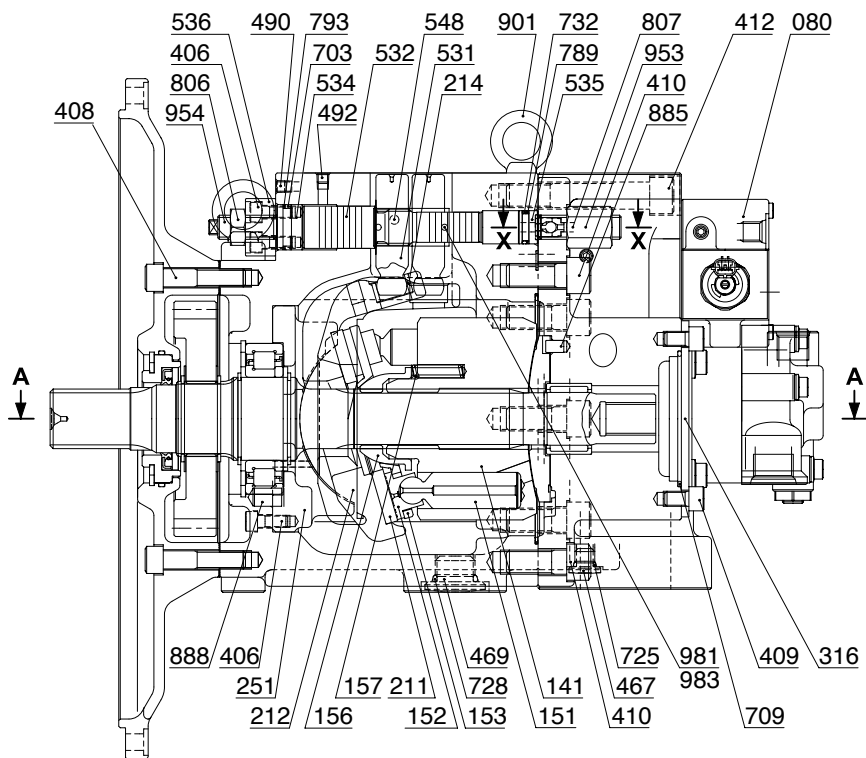

**SECTION X-X**

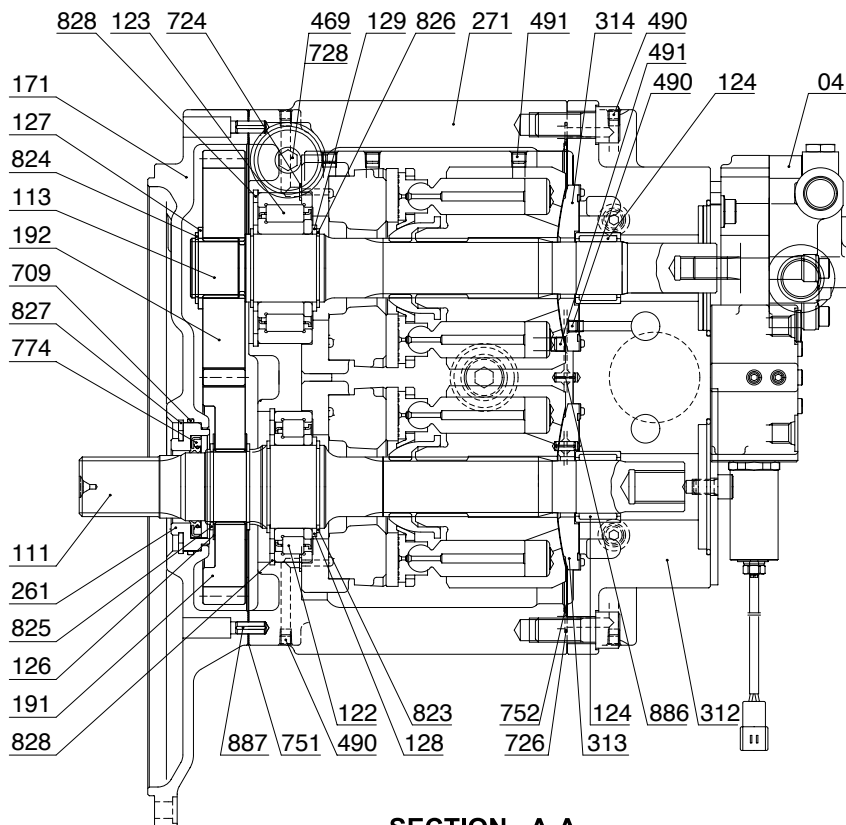

**SECTION A-A**

04	Gear pump	312	Valve cover	712	O-ring
080	Proportional reducing valve assy	313	Valve plate(R)	724	O-ring
111	Drive shaft	314	Valve plate(L)	725	O-ring
113	Driven shaft	316	Cover	726	O-ring
122	Roller bearing	406	Hexagon socket bolt	728	O-ring
123	Roller bearing	408	Hexagon socket bolt	732	O-ring
124	Needle bearing	409	Hexagon socket bolt	735	O-ring
126	Bearing spacer	410	Hexagon socket bolt	751	Packing
127	Bearing spacer	412	Hexagon socket bolt	752	Seat packing
128	Bearing spacer	467	Plug	774	Oil seal
129	Bearing spacer	469	Plug	789	Back up ring
141	Cylinder block	490	Plug	793	Back up ring
151	Piston	491	Plug	806	Nut
152	Shoe	492	Restrictor	807	Nut
153	Set plate	531	Tilting pin	823	Snap ring
156	Bushing	532	Servo piston	824	Snap ring
157	Cylinder spring	534	Stopper(L)	825	Snap ring
171	Front casing	535	Stopper(S)	827	Snap ring
191	Drive gear	536	Servo cover	828	Snap ring
192	Driven gear	541	Seat	885	Valve plate pin
211	Shoe plate	543	Stopper	886	Spring pin
212	Swash plate	545	Steel ball	887	Spring pin
214	Tilting bushing	548	Feed back pin	888	Pin
251	Swash plate support	703	O-ring	901	Eye bolt
261	Front cover	709	O-ring	953	Set screw
271	Pump casing	711	O-ring	954	Set screw

**MAIN PUMP(2/2)**

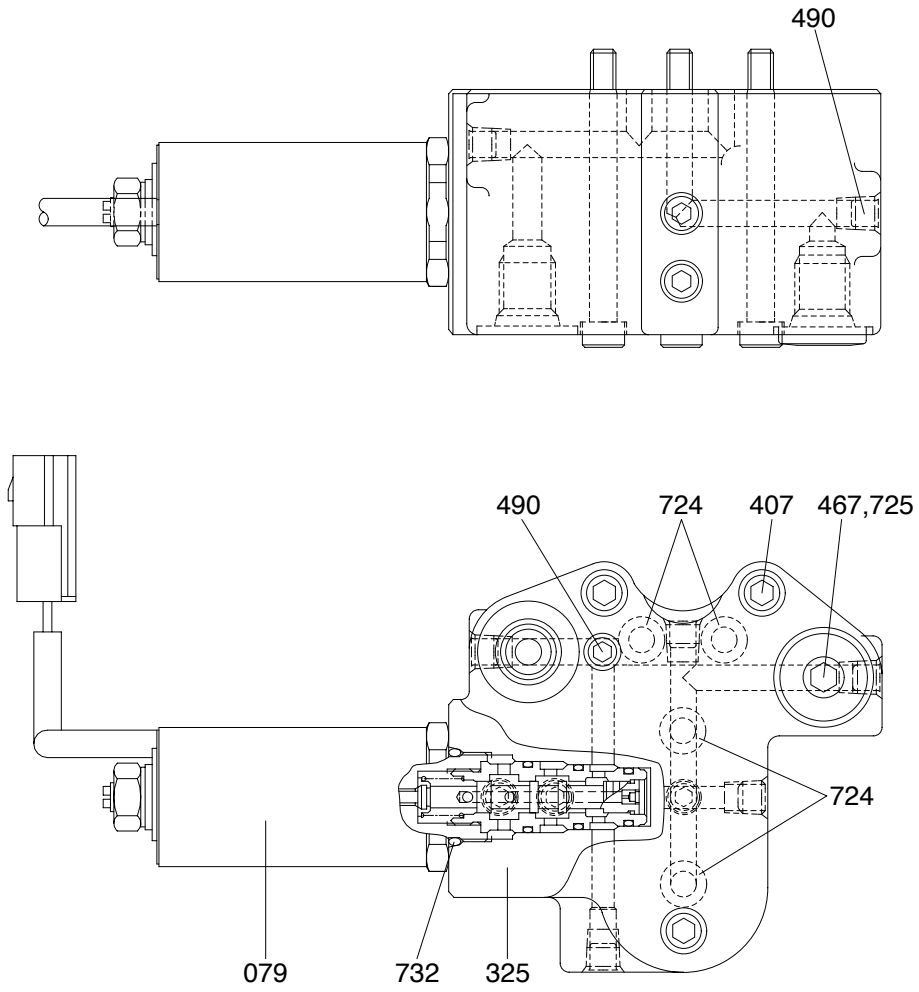

- 079 Proportional reducing valve
- 325 Valve casing
- 407 Hexagon socket screw

- 467 Plug
- 490 Plug
- 724 O-ring



- 725 O-ring
- 732 O-ring

210N72MP03

## 2) TOOLS AND TIGHTENING TORQUE

### (1) Tools

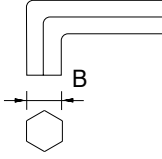
The tools necessary to disassemble/reassemble the pump are shown in the follow list.

Tool name & size		Part name			
Allen wrench  	B	Hexagon socket head cap screw	PT plug (PT thread)	PO plug (PF thread)	Servo piston
	4	M 5	BP-1/16	-	-
	5	M 6	BP-1/ 8	-	-
	6	M 8	BP-1/ 4	PF-1/4	-
	8	M10	BP-3/ 8	PF-3/8	-
	10	M12	BP-1/2	PF-1/2	-
	14	M16, M18	BP-3/4	PF-3/4	M24
	17	M20, M22	BP-1	PF-1	-
	19	M24, M27	-	-	-
Double ring spanner, socket wrench, double(Single) open end spanner  	-	Hexagon head screw	Hexagon nut	Hexagon socket head set screw	
	19	M12	M12	-	
	24	M16	M16	-	
	27	M18	M18	-	
	30	M20	M20	-	
	36	-	-	-	
	46	M30	M30	-	
Adjustable angle wrench	Medium size, 1 set				
Screw driver	Minus type screw driver, Medium size, 2 sets				
Hammer	Plastic hammer, 1 set				
Pliers	For snap ring, TSR-160, TSR200				
Steel bar	Steel bar of key material approx. 10 × 8 × 200				
Torque wrench	Capable of tightening with the specified torques				
Seal tape	For BP-1/4				

**(2) Tightening torque**

Part name	Bolt size	Torque		Wrench size	
		kgf · m	lbf · ft	in	mm
Hexagon socket head bolt (Material : SCM435)	M 5	0.7	5.1	0.16	4
	M 6	1.2	8.7	0.20	5
	M 8	3.0	21.7	0.24	6
	M10	5.8	42.0	0.31	8
	M12	10.0	72.3	0.39	10
	M14	16.0	115.7	0.47	12
	M16	24.0	173.6	0.55	14
	M18	34.0	245.9	0.55	14
	M20	44.0	318.3	0.67	17
	M22	64.0	462.9	0.67	17
PT plug(Material : S45C) Wind a seal tape 1 1/2 to 2 turns round the plug	PT 1/16	0.7	5.1	0.16	4
	PT 1/ 8	1.05	7.59	0.20	5
	PT 1/ 4	1.75	12.66	0.24	6
	PT 3/ 8	3.5	25.3	0.31	8
	PT 1/ 2	5.0	36.2	0.39	10
PF plug(Material : S45C)	PF 1/ 4	3.0	21.7	0.24	6
	PF 1/ 2	10.0	72.3	0.39	10
	PF 3/ 4	15.0	108.5	0.55	14
	PF 1	19.0	137.4	0.67	17
	PF 1 1/4	27.0	195.3	0.67	17
	PF 1 1/2	28.0	202.5	0.67	17

### 3) DISASSEMBLY

- (1) Select place suitable to disassembling.  
Select clean place.  
Spread rubber sheet, cloth or so on overhaul workbench top to prevent parts from being damaged.  
Fix pump casing(271) by using thread 2-M10 x 16 in disassembling.
- (2) Remove dust, rust, etc, from pump surfaces with cleaning oil or so on.
- (3) Remove outlet port plug(469, lower part of pump casing) and let the oil out of pump casing.  
In order to be let the oil out of pump casing easily, remove oil filling port plug(469, upper part of pump casing).
- (4) Remove hexagon socket head cap screws(412, 413) and remove regulators.  
In order to avoid mixing up regulator of drive shaft side with that of driven shaft side, mark each of them.  
Remove hexagon socket head cap screws(435) and remove gear pump.  
Remove hexagon socket head cap screws(407) and remove proportional reducing valve.
- (5) Loosen hexagon socket head cap screws(410, 412) which tighten valve cover(312).
- (6) Loosen hexagon socket head cap screws(410, 411) which tighten valve cover(312).  
Remove regulators, gear pump and proportional reducing valve before starting this work.

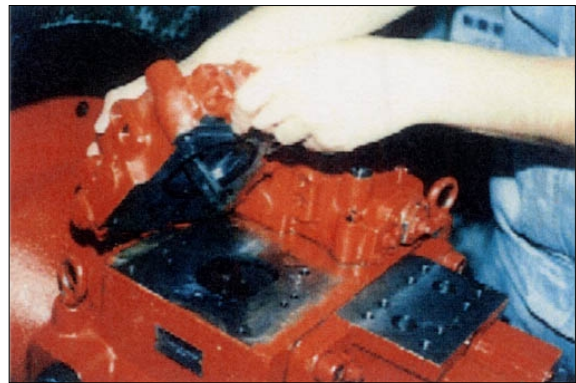

210N78MP29

- (7) Place pump horizontally on workbench and separate pump casing(271) and valve cover(312).

Remove valve cover carefully at this work because it is heavy(about 29kgf).

There are two spring pins for fixing position between pump casing and valve cover. Since they have a tight fit, remove valve cover upright with respect to drive shaft(111) and driven shaft(113), while lightly tapping the valve cover with a plastic hammer.

Take care not to damage fitting surfaces between pump casing and valve cover.

Take care not to drop valve plates(313, 314), check valve subassemblies(541, 543, 545), O-rings (735) and seat packing(752) in removing valve cover.

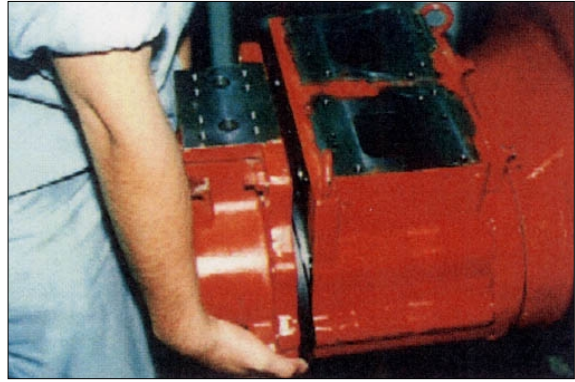

210N78MP03

- (8) If necessary, remove needle bearings(124) from valve cover(312).

Do not remove needle bearings as far as possible, except when it is considered to be out of its life span.

Do not loosen hexagon nut(807) of the valve cover. If loosened, flow setting will be changed.

- (9) Pull cylinders out of pump casing(271) straightly over drive shaft(111) and driven shaft(113). Pull out also pistons(151), set plate(153), spherical bush(156) and cylinder springs(157) simultaneously.

Take care not to damage sliding surfaces of cylinder, spherical bush, shoes, swash plate, and so on.

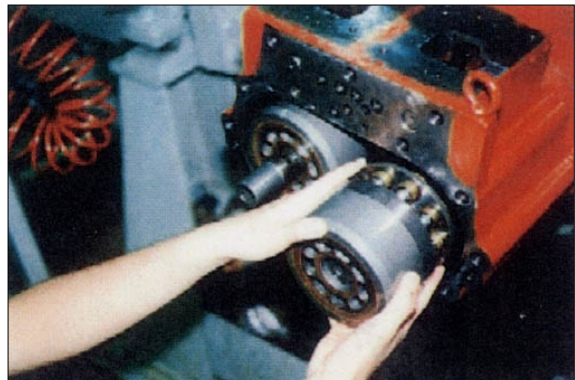

210N78MP04

- (10) Remove shoe plate(211) and swash plate(212) from pump casing(271).  
Separate shoe plate from swash plate, using a flat-blade screwdriver.  
Then remove swash plate.

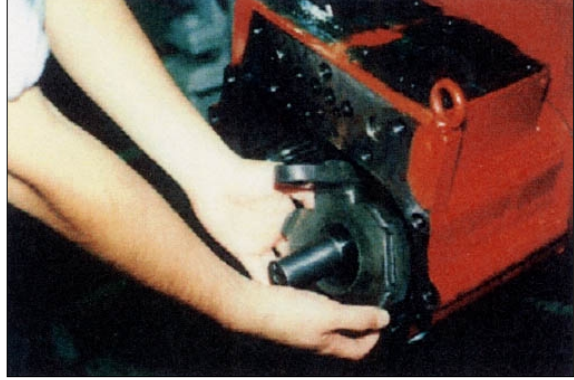

210N78MP05

- (11) If necessary, remove stopper(L, 534), stopper(S, 535), servo piston(532), tilting pin(531), and servo cover(536) from pump casing(271).  
In removing tilting pin, use a protector to prevent pin head from being damaged.  
Since adhesive(No.1305N of Threebond make) is applied to fitting areas of tilting pin and servo piston, take care not to damage servo piston.  
Do not loosen hexagon nut(806) on servo cover(536). If loosened, flow setting will be changed.

- (12) Remove snap ring(827) and front cover(261) from front casing(171).  
A groove is provided on the outer circumference of front cover straight with respect to drive shaft(111) by placing a minus type screwdriver in the groove.  
Since oil seal(774) is fitted on front cover(261), take care not to damage it in removing.

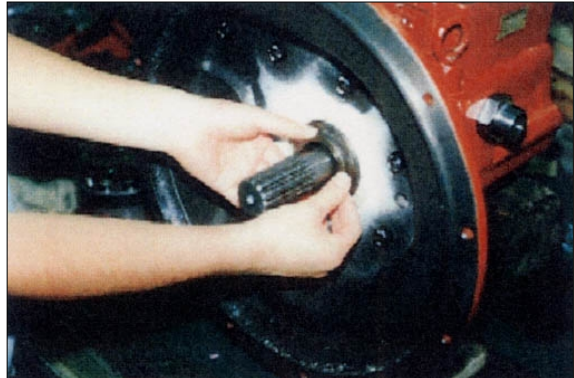

210N78MP06

- (13) Loosen hexagon socket head cap screws(408) which tighten front casing(171).

- (14) Separate front casing(171) and pump casing(271).

Take care of front casing not to fall because it is heavy(about 23kgf).

There are two spring pins(887) for fixing position between front casing and pump casing. Tapping lightly with a plastic hammer, remove front casing perpendicular to drive shaft because they are fitted firmly. When removing, take care not to damage oil seal sliding surface of drive shaft.

Take care not to damage fitting surfaces between front casing and pump casing.

There is a packing(751) between front casing and pump casing. The packing is made of synthetic resin and easy to break. In case it is broken or scored, replace it with a new one.

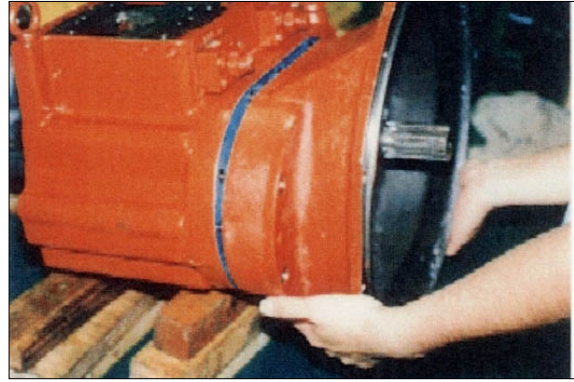

210N78MP07

- (15) Remove snap rings(824, 825), bearing spacers(126, 127), drive gear(191) and driven gear(192).

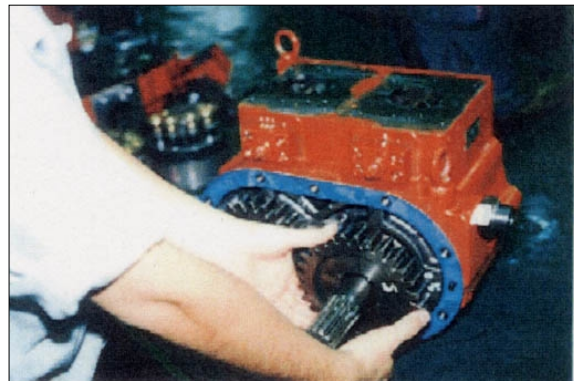

210N78MP24

- (16) Remove snap ring(828) and take out drive shaft(111) and driven shaft(113) tapping lightly ends of them by plastic hammer and so on.

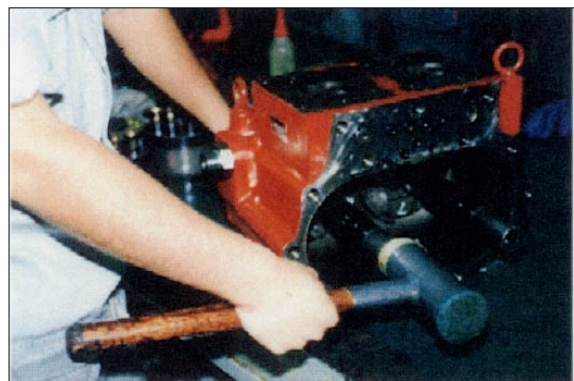

210N78MP08

(17) If necessary, remove snap rings(823, 825, 826), bearing spacer(128, 129), and roller bearing(122, 123) from drive shaft(111) and driven shaft(113).

Do not remove roller bearing as far as possible, except when it is considered to be out of its life span. Use a specified jig in removing because roller bearing is shrinkage fitted to shaft.

(18) Loosen hexagon socket head cap screws(406) which tighten swash plate supports(251) and pump casing(271).

Adhesive(No.1305N of Threebond make) is applied to hexagon socket head cap screws(406).

(19) Remove swash plate supports(251) from pump casing(271).

This is the end of disassembling procedures.

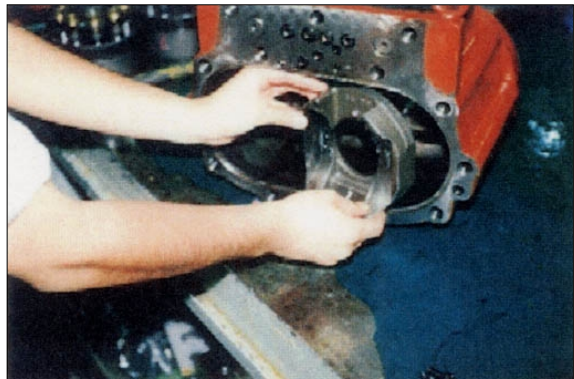

210N78MP09

#### 4) REASSEMBLY

- (1) For reassembling reverse the disassembling procedures, paying attention to the following items.

Do not fail to repair the parts damaged during disassembling, and repair replacement parts in advance.

Clean each part fully with cleaning oil and dry it with compressed air.

Do not fail to apply clean working oil to sliding surfaces, bearings, etc. before assembling them.

In principle, replace seal parts, such as O-rings, oil seals, etc.

Apply grease to O-rings, seat packing, and check valves in assembling them because they tend to come off.

In case of parallel type pump, rotating directions of drive shaft and driven shaft are different. Take care not to mix up parts of the drive shaft side with those of the driven shaft side.

For fitting bolts, plug, etc., prepare a torque wrench or so on, and tighten them with specified torques in this service manual.

- (2) Select place suitable to assembling.

Select clean place.

Spread rubber sheet, cloth or so on overhaul workbench top to prevent parts from being damaged.

Fix pump casing(271) by using thread 2-M10 x 16 in assembling.

- (3) Fit swash plate support(251) to pump casing(271) and fix them with hexagon socket head cap screws(406).

There are O-rings(724) on the matching surface in contact with pump casing(271). Fix them with grease so they do not come off.

Positioning pin(888) is placed on the pump casing(271) side. Adjust it so it enters the groove of swash plate support(251) and fix it.

Fit swash plate support(251) so it enters straight, while tapping it lightly.

Apply adhesive(No.1305N of Threebond make) to hexagon socket head cap screws.

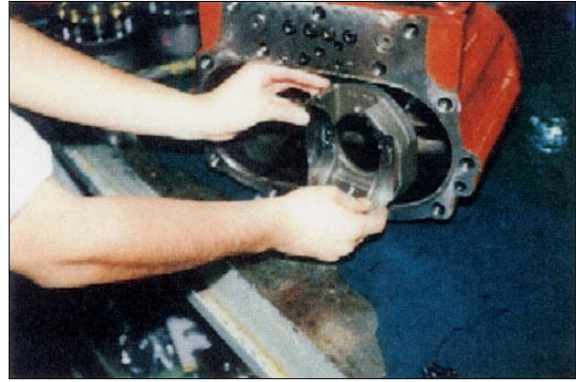

210N78MP09



210N78MP12

- (4) To pump casing(271), fit drive shaft(111) set and driven shaft(113) set with roller bearing(122, 123), bearing spacer(128, 129), and snap rings(823, 826). Then fix them with snap rings(828).

Direct the sharp edge side of snap rings(823, 826) to the outside.

Do not tap shafts with hammer or so on.

Assemble them into pump casing, tapping outer race of bearing lightly with plastic hammer. Fit them fully using steel bar or so on.

When fitting snap rings(828), direct the sharp edge side of snap ring to the outside.



45078MP13

- (5) Fit drive gear(191), driven gear(192), and bearing spacers(126, 127) to drive shaft(111) and driven shaft(113). Then fix them with snap rings(824, 825).

Confirm the attaching direction of drive gear before fitting.

Direct the sharp edge of snap rings(824, 825) to the outside.

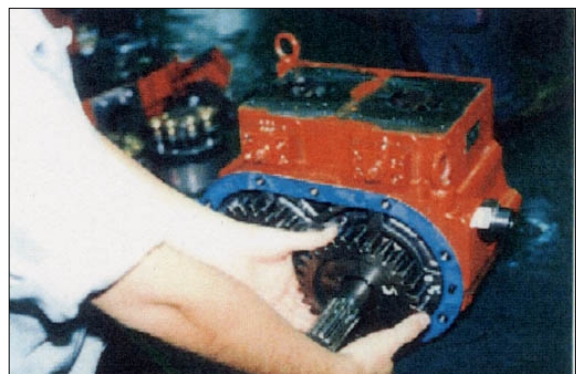

210N78MP24

- (6) Fit front casing(171) to pump casing(271) and fix them with hexagon socket head cap screws(408).

Take care of front casing not to fall because it is heavy(about 23kgf).

There are two spring pins(887) for fixing position between front casing and pump casing. Always fit spring pins(887) to the pump casing side.

Fit front casing to pump casing perpendicular to drive shaft, while tapping it lightly because spring pin(886) has a tight fit. When fitting, take care not to damage oil seal sliding surface of drive shaft.

Take care not to damage fitting surfaces of front casing and pump casing.

There is a packing(751) between front casing and pump casing. The packing is made of synthetic resin and easy to break. In case it is broken or scored, replace it with a new one.

Apply grease to seat packing(751) because it tends to come off.

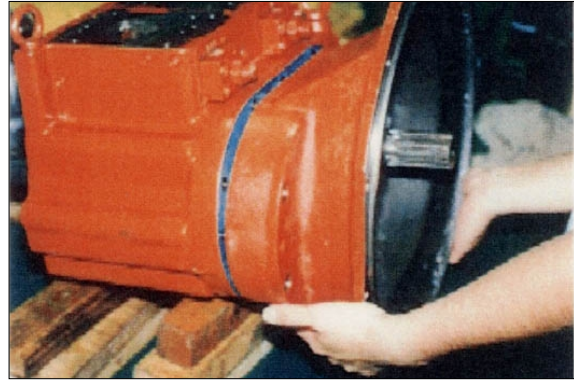

210N78MP07



210N78MP16

- (7) Fit front cover(261) to front casing(171) and fix them with snap ring(827).

Apply grease lightly to oil seal in front cover.

Assembling oil seal, take full care not to damage it.

Direct the sharp edge of snap ring(827) to the outside.



210N78MP06

- (8) Place pump casing(271) horizontally. Fit servo piston(532), tilting pin(531), stopper(L, 534), and stopper(S, 535) to pump casing. Then fit servo cover(536) to pump casing and fix them with hexagon socket head cap screws(406).

Fix pump casing by using thread 2-M10 x 16 in assembling.

In tightening servo piston and tilting pin, use a protector to prevent tilting pin head and feedback pin from being damaged. In addition apply adhesive (No.1305N of Threebond make) to their threaded sections.

- (9) Fit tilting bush(214) of swash plate(212) to tilting pin(531) and fit swash plate to swash plate support(251) correctly. Take care not to mix up parts of drive shaft side with those of driven shaft side. Even after fitting, swash plate(212) comes off from swash plate support(251), in some cases. They do not come off easily if grease is applied to the sliding surfaces. Confirm with fingers of both hands that swash plate can be moved smoothly.

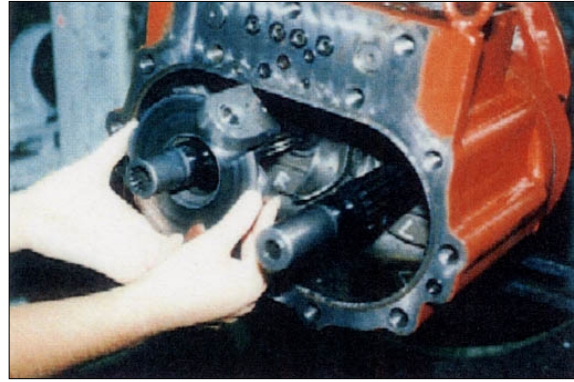

210N78MP17

- (10) Assemble piston cylinder subassembly [cylinder(141), piston subassembly(151, 152), set plate(153), spherical bush(156), cylinder spring(157)]. Fit spline phases of spherical bush and cylinder and insert piston cylinder subassembly into pump casing with respect to drive shaft(111) and driven shaft(113). Take care not to mix up parts of drive shaft side with those of driven shaft side. Confirm that swash plate(212) is not off from swash plate support(251) and from tilting pin(531), before inserting them.

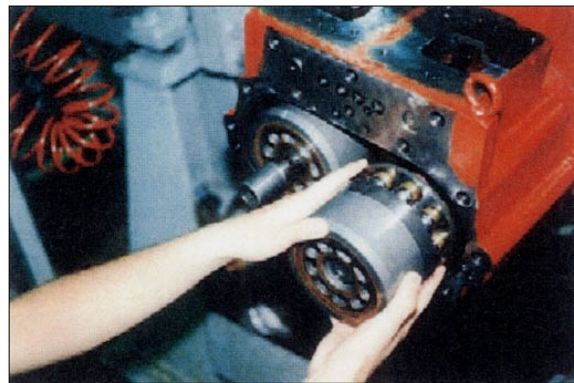

210N78MP25

- (11) Fit valve plates(313, 314) to valve cover, entering valve plate pin(885) into pin hole. Take care not to mistake suction/delivery directions of valve plate. Apply grease to matching surface in contact with valve cover(312) because valve plates(313, 314) tend to come off.

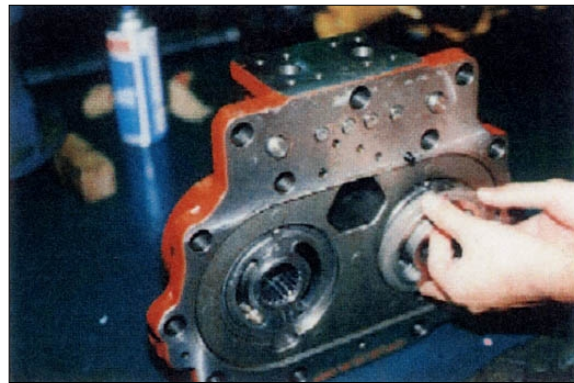

210N78MP18

- (12) Insert check valve subassemblies(541, 543, 545) and needle bearings(124) to valve cover(312). Insert check valve subassemblies into valve cover in correct order. Since check valve subassembly tends to come off, apply grease to matching part of valve cover(312).

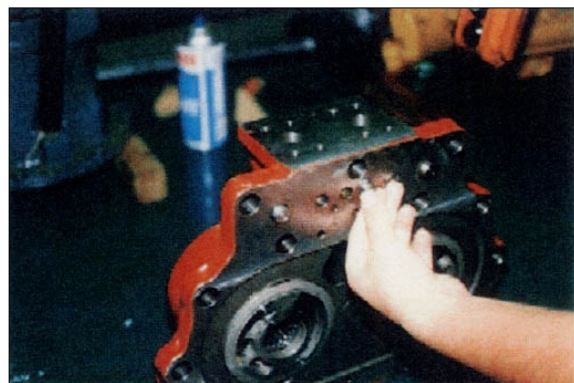

210N78MP26

- (13) Fit O-ring(724, 725, 726) and seat packing(752) to the matching surface of pump casing(271) in contact with valve cover(312).

Since O-rings and seat packing tend to come off, apply grease to matching surface.

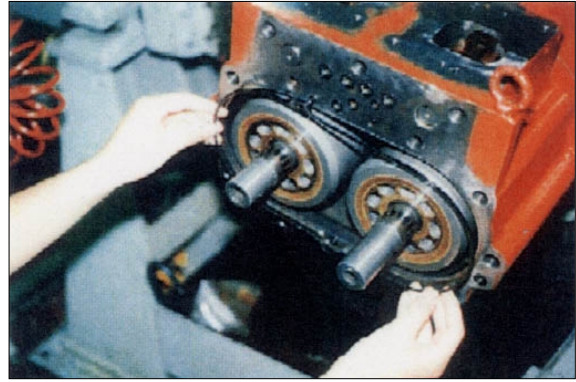

210N78MP19

- (14) Fit valve cover(312) to pump casing(271) and tighten them with hexagon socket head cap screws(410, 412).

Crane valve cover at this work because it is heavy(about 29kgf).

Confirm that swash plate(212) is not off from swash plate support(251) and tilting pin(531) before fitting.

Needle bearings(124) are located on the valve cover side place the valve cover with care.

When fitting, take care as valve plates(313, 314) check valve subassemblies (541, 543, 545), O-rings (735), and seat packing(752) may come off in some cases.

There are two spring pins(886) for fixing position between pump casing and valve cover. Since spring pin(886) has a tight fit, fit valve cover upright to drive shaft(111) and driven shaft(113), while tapping it with a plastic hammer.

Take care not to damage fitting surfaces between valve cover and pump casing.

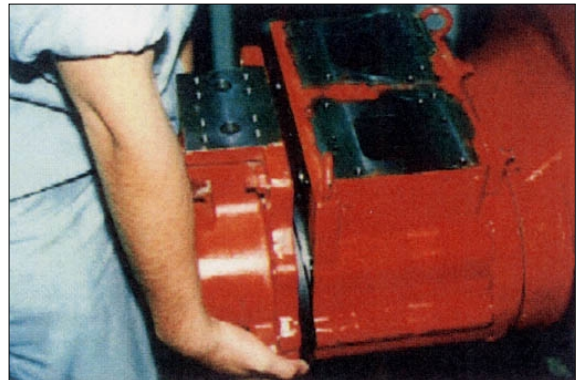

210N78MP03

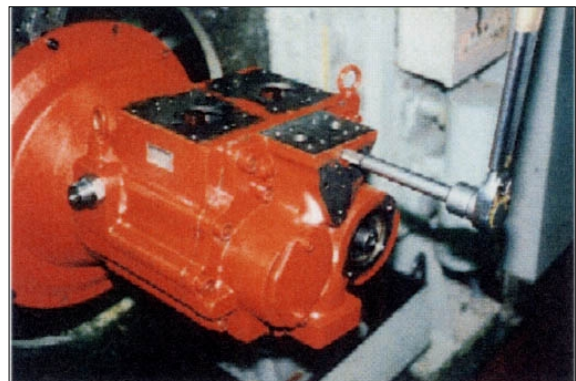

210N78MP21

(15) Putting feedback pin(548) of tilting pin(531) into feedback lever of regulator, fit regulator and tighten hexagon socket head cap screws(412, 413).

Since the regulators on the drive shaft side and the driven shaft side are set at different pressure and flow values, take care not to mistake one for another.

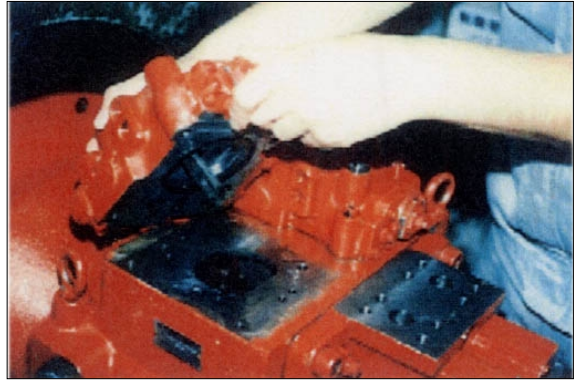

210N78MP29

(16) Install gear pump(04) and proportional reducing valve(080) and tighten them with flang socket bolt(435) (for gear pump) and hexagon socket head cap screws(407) (for proportional reducing valve).

Since gear pump is an aluminum casing, the tightening torque for the flang socket bolts(435) differs from it for hexagon socket head cap screw.

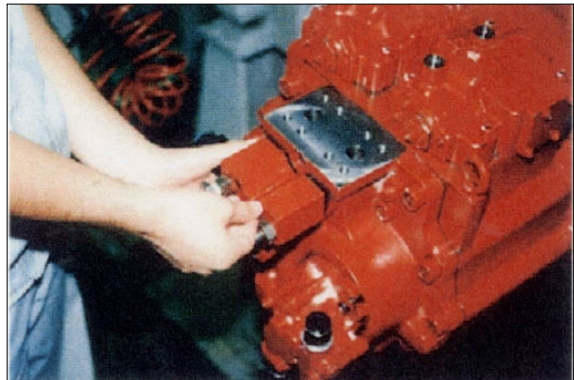

210N78MP28

### 5) REGULATOR(1/2)

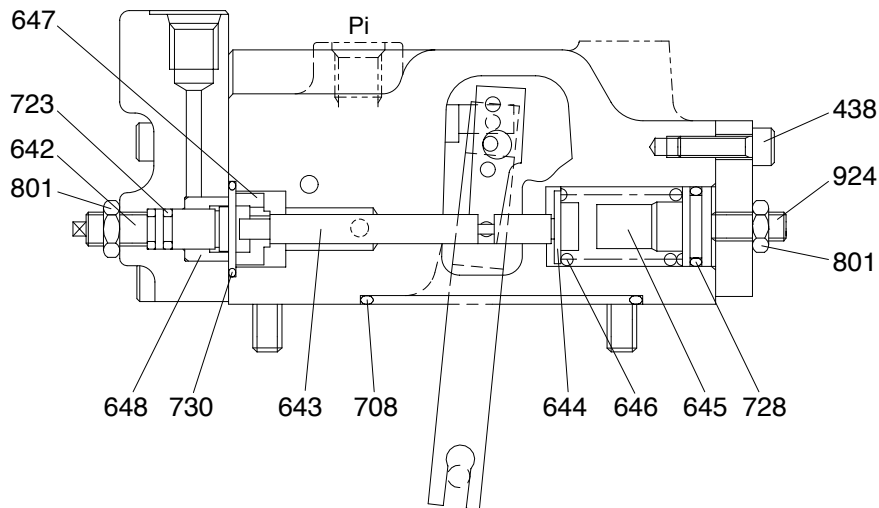
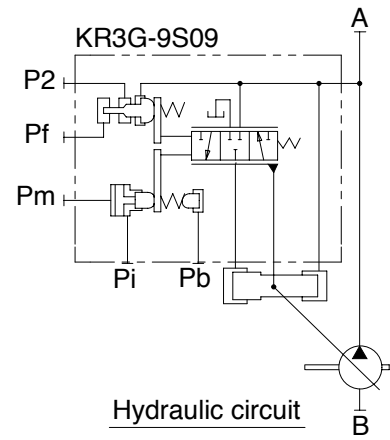
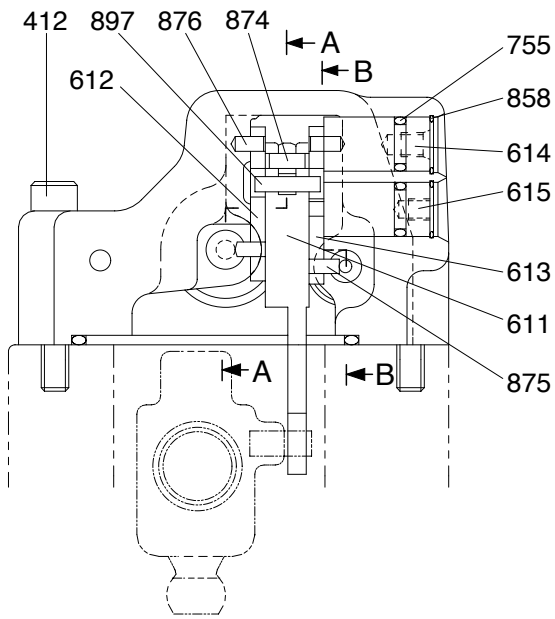

SECTION B-B

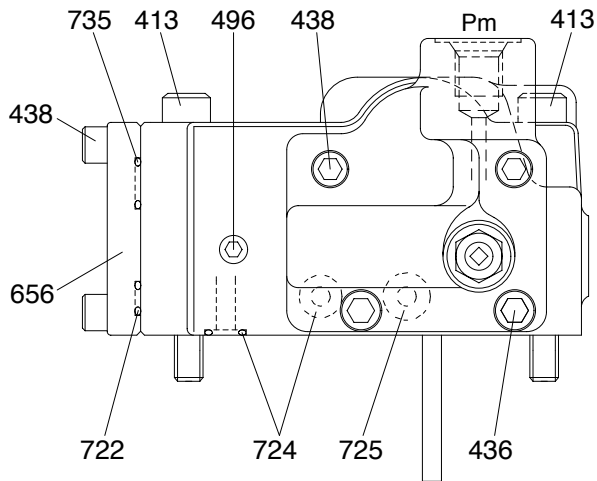

VIEW C

210N72RG01

Port	Port name	port size
Pi	Pilot port	PF 1/4 - 15
Pm	Qmax cut port	PF 1/4 - 15

## REGULATOR(2/2)

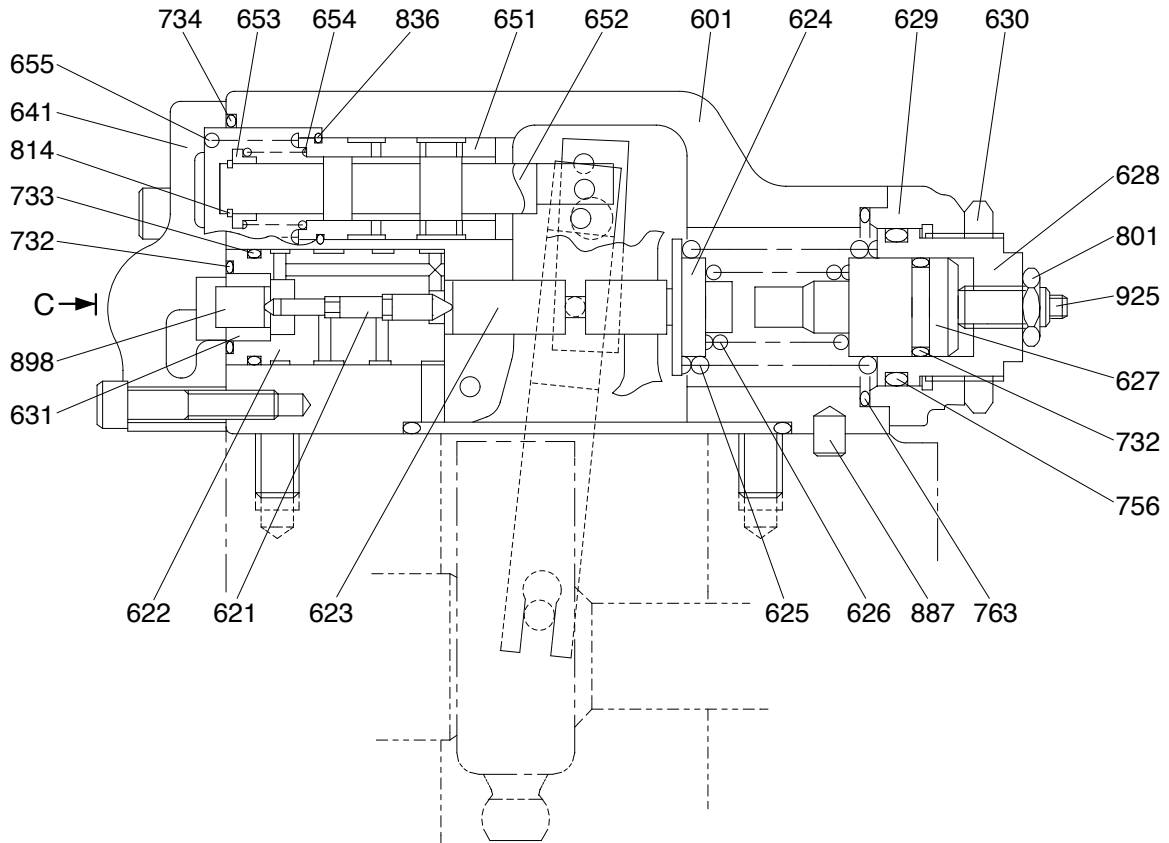

SECTION A-A



210N72RG02

412 Hexagon socket screw	631 Sleeve, pf	730 O-ring
413 Hexagon socket screw	641 Pilot cover	732 O-ring
436 Hexagon socket screw	642 Adjust screw(QMC)	733 O-ring
438 Hexagon socket screw	643 Pilot piston	734 O-ring
496 Plug	644 Spring seat(Q)	735 O-ring
601 Casing	645 Adjust stem(Q)	755 O-ring
611 Feed back lever	646 Pilot spring	756 O-ring
612 Lever(1)	647 Stopper	763 O-ring
613 Lever(2)	648 Piston(QMC)	801 Nut
614 Center plug	651 Sleeve	814 Snap ring
615 Adjust plug	652 Spool	836 Snap ring
621 Compensator piston	653 Spring seat	858 Snap ring
622 Piston case	654 Return spring	874 Pin
623 Compensator rod	655 Set spring	875 Pin
624 Spring seat(C)	656 Block cover	876 Pin
625 Outer spring	708 O-ring	887 Pin
626 Inner spring	722 O-ring	897 Pin
627 Adjust stem(C)	723 O-ring	898 Pin
628 Adjust screw(C)	724 O-ring	924 Set screw
629 Cover(C)	725 O-ring	925 Adjust screw(QI)
630 Lock nut	728 O-ring	

## 6) TOOLS AND TIGHTENING TORQUE

### (1) Tools

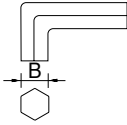
The tools necessary to disassemble/reassemble the regulators are shown in the follow list.

Tool name & size		Part name			
Name	B	Hexagon socket head bolt	PT plug (PT thread)	PO plug (PF thread)	Hexagon socket head setscrew
Allen wrench 	4	M 5	BP-1/16	-	M 8
	5	M 6	BP-1/8	-	M10
	6	M 8	BP-1/4	PO-1/4	M12, M14
Double ring spanner, socket wrench, double(Single) open end spanner 	-	Hexagon head bolt	Hexagon nut	VP plug (PF thread)	
	36	-	-	VP-3/4	
Adjustable angle wrench	Medium size, 1set				
Screw driver	Minus type screw driver, Medium size, 2 sets				
Hammer	Plastic hammer, 1 set				
Pliers	For snap ring, TSR-150				
Steel bar	Ø4 × 100mm				
Torque wrench	Capable of tightening with the specified torques				
Pincers	-				
Hexagon socket head cap screw	M4 × 50mm				

**(2) Tightening torque**

Part name	Bolt size	Torque		Wrench size	
		kgf · m	lbf · ft	in	mm
Hexagon socket head bolt Material : SCM435)	M 5	0.7	5.1	0.16	4
	M 6	1.2	8.7	0.20	5
	M 8	3.0	21.7	0.24	6
	M10	5.8	42.0	0.31	8
	M12	10.0	72.3	0.39	10
	M14	16.0	116	0.47	12
	M16	24.0	174	0.55	14
	M18	34.0	246	0.55	14
	M20	44.0	318	0.67	17
PT Plut(Material : S45C) Wind a seal tape 1 1/2 to 2 turns round the plug	PT1/16	0.7	5.1	0.16	4
	PT 1/8	1.05	7.59	0.20	5
	PT 1/4	1.75	12.7	0.24	6
	PT 3/8	3.5	25.3	0.31	8
	PT 1/2	5.0	36.2	0.39	10
PF Plut(Material : S35C)	PF 1/4	3.0	21.7	0.24	6
	PF 1/2	10.0	72.3	0.39	10
	PF 3/4	15.0	109	0.55	14
	PF 1	19.0	137	0.67	17
	PF 1 1/4	27.0	195	0.67	17
	PF 1 1/2	28.0	203	0.67	17

### 3) DISASSEMBLY

Since the regulator consists of small precision finished parts, disassembling and assembling are rather complicated.

For this reason, replacement of a regulator assembly is recommended, unless there is a special reason, but in case disassembling is necessary for an unavoidable reason, read through this manual to the end before starting disassembling.

- (1) Select a place for disassembling.

Select a clean place.

Spread rubber sheet, cloth, or so on top of work-bench to prevent parts from being damaged.

- (2) Remove dust, rust, etc. from surfaces of regulator with clean oil.

Since the regulators on the drive shaft side and the driven shaft side are set at different pressure and flow values, mark each of them so as not to mix up one of drive shaft side with another.

- (3) Remove hexagon socket head cap screw (412, 413) and remove regulator main body from pump main body.

Take care not to lose O-ring.

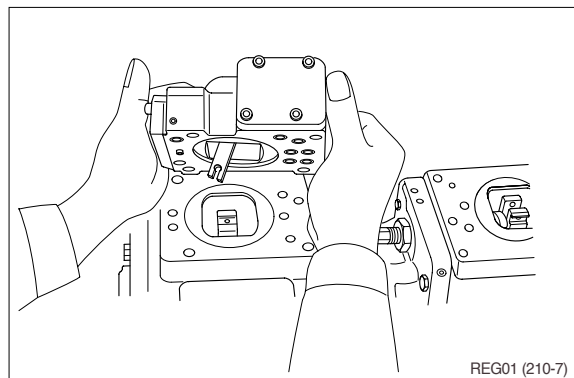

- (4) Remove hexagon socket head screw (438) and remove cover(C,629)

Cover(C) is fitted with adjusting screw (C,QI) (628, 925), adjusting ring(C, 627), lock nut(630), hexagon nut(801) and adjusting screw(924).

Do not loosen these screws and nuts.

If they are loosened, adjusted pressure-flow setting will vary.

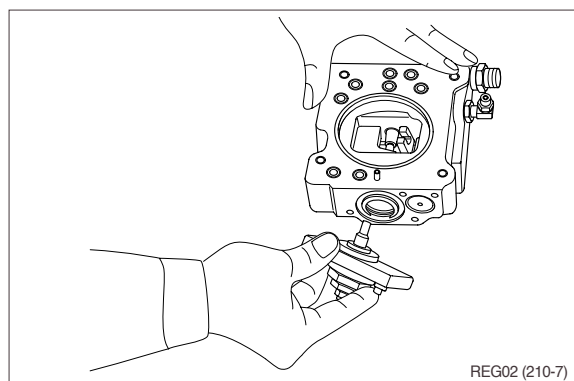

- (5) After removing cover(C, 629) subassembly, take out outer spring(625), inner spring (626) and spring seat(C, 624) from compensating section.

Then draw out adjusting ring(Q, 645), pilot spring(646) and spring seat(644) from pilot section.

Adjusting ring(Q,645) can easily be drawn out with M4 bolt.

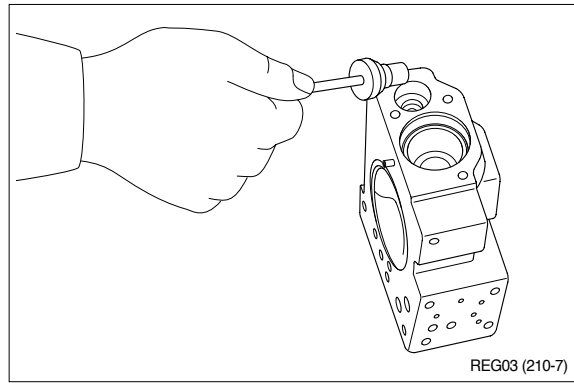

- (6) Remove hexagon socket head screws (436, 438) and remove pilot cover(641).

After removing pilot cover, take out set spring(655) from pilot section.

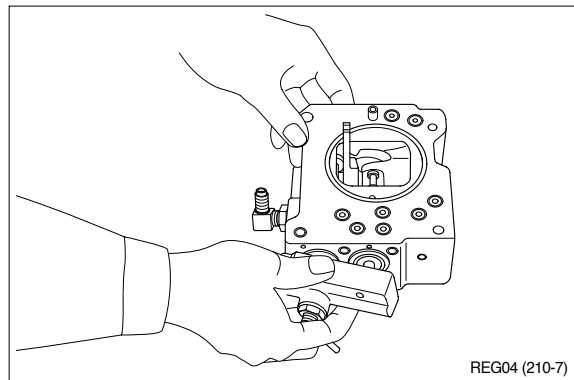

- (7) Remove snap ring(814) and take out spring seat(653), return spring(654) and sleeve(651).

Sleeve(651) is fitted with snap ring(836).

When removing snap ring(814), return spring(654) may pop out.

Take care not to lose it.

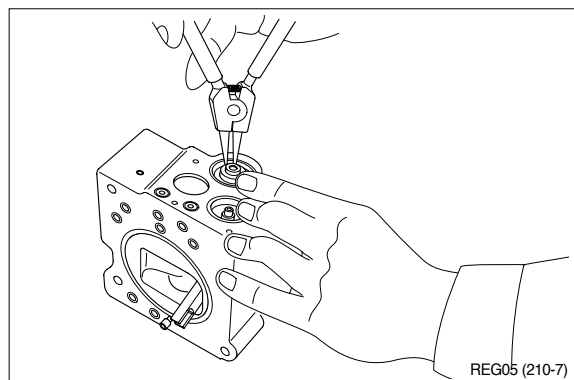

- (8) Remove snap ring(858) and take out fulcrum plug(614) and adjusting plug (615).

Fulcrum plug(614) and adjusting plug (615) can easily be taken out with M6 bolt.

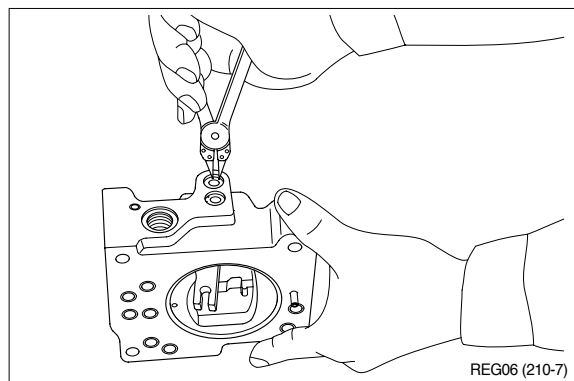

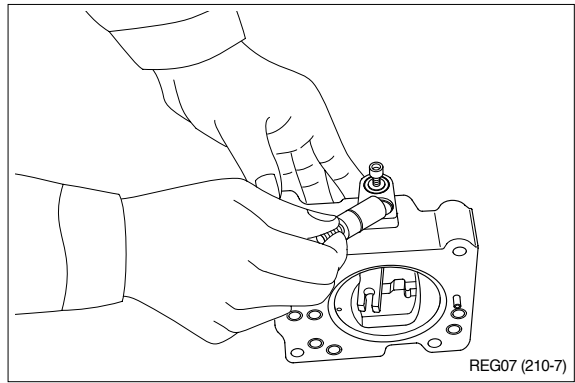

- (9) Remove lever(2, 613). Do not draw out pin(875).  
Work will be promoted by using pincers or so on.

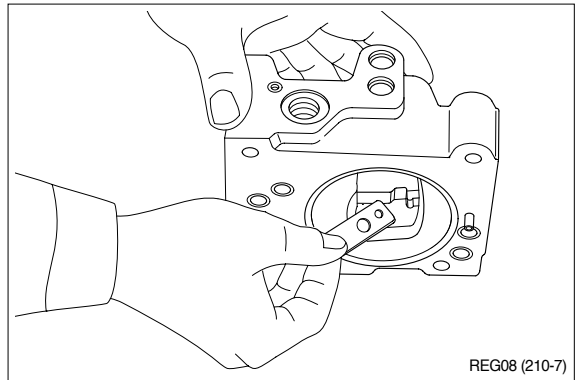

- (10) Draw out pin(874) and remove feedback lever(611).  
Push out pin(874, 4mm in dia.) from above with slender steel bar so that it may not interfere with lever(1, 612).

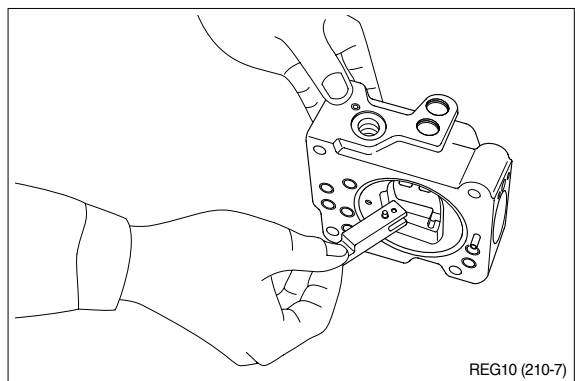
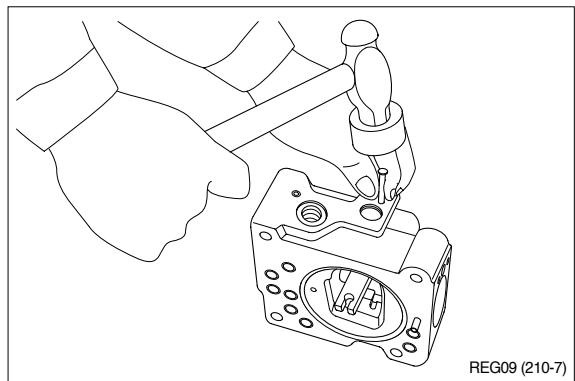

(11) Remove lever(1, 612). Do not draw out pin(875).

(12) Draw out pilot piston(643) and spool(652).

(13) Draw out piston case(622), compensating piston(621) and compensating rod(623).

Piston case(622) can be taken out by pushing compensating rod(623) at opposite side of piston case.

This completes disassembling.

#### 4) ASSEMBLY

- (1) For assembling, reverse disassembling procedures, but pay attention to the following.

Always repair parts that were scored at disassembling.

Get replacement parts ready beforehand.

Mixing of foreign matter will cause malfunction.

Therefore, wash parts well with cleaning oil, let them dry with jet air and handle them in clean place.

Always tighten bolts, plugs, etc. to their specified torques.

Do not fail to coat sliding surfaces with clean hydraulic oil before assembling.

Replace seals such as O-ring with new ones as a rule.

- (2) Put compensating rod(623) into compensating hole of casing(601).
- (3) Put pin force-fitted in lever(1, 612) into groove of compensating rod and fit lever (1) to pin force-fitted in casing.

- (4) Fit spool(652) and sleeve(651) into hole in spool of casing.  
Confirm that spool and sleeve slide smoothly in casing without binding.  
Pay attention to orientation of spool.

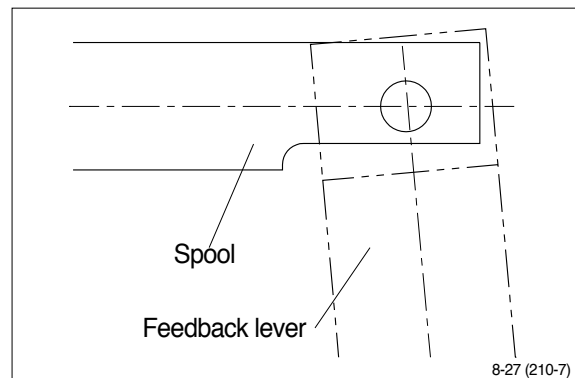

- (5) Fit feedback lever(611), matching its pin hole with pin hole in spool.  
Then insert pin(874).  
Insert pin in feedback lever a little to ease operation.  
Take care not to mistake direction of feedback lever.

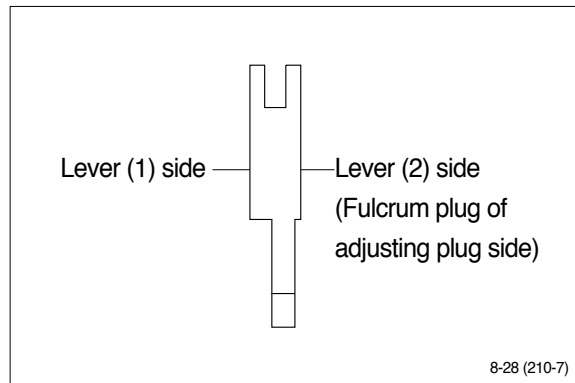

- (6) Put pilot piston(643) into pilot hole of casing.  
Confirm that pilot piston slides smoothly without binding.
- (7) Put pin force-fitted in lever(2, 613) into groove of pilot piston.  
Then fix lever(2).

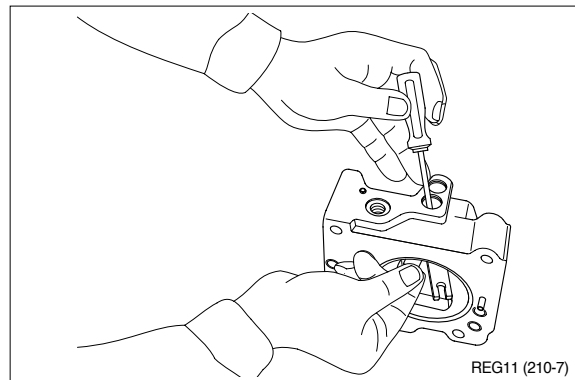

- (8) Fit fulcrum plug(614) so that pin force-fitted in fulcrum plug(614) can be put into pin hole of lever(2).  
Then fix snap ring(858).
- (9) Insert adjusting plug(615) and fit snap ring.  
Take care not to mistake inserting holes for fulcrum plug and adjusting plug.  
At this point in time move feedback lever to confirm that it has no large play and is free from binding.

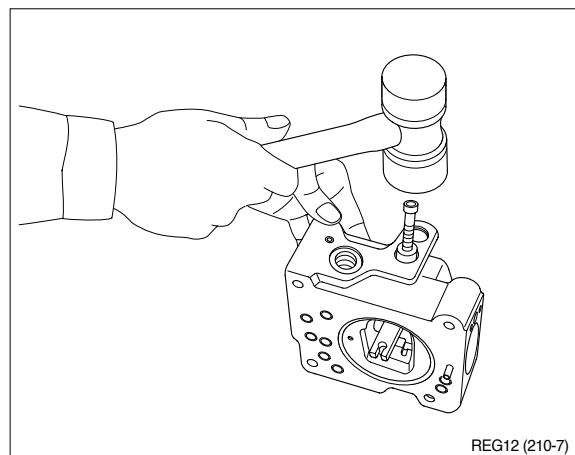

- (10) Fit return spring(654) and spring seat (653) into spool hole and attach snap ring (814).

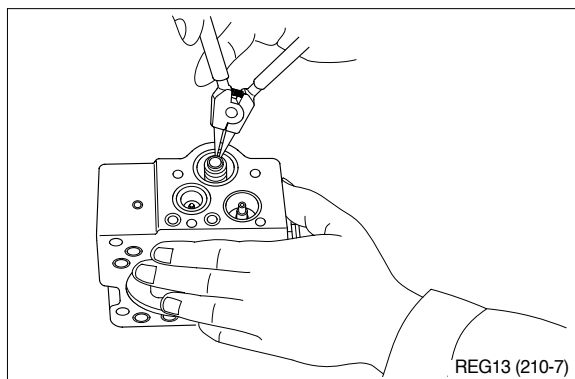

- (11) Fit set spring(655) to spool hole and put compensating piston(621) and piston case(622) into compensating hole.  
Fit pilot cover(641) and tighten it with hexagonal socket head screws(436, 438).  
Confirm that pin(898) slides smoothly in pf sleeve(631) without binding.

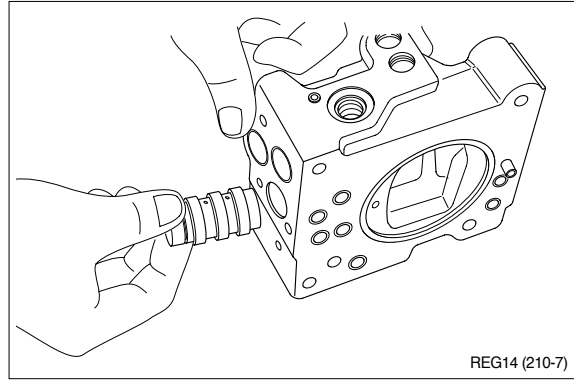

- (12) Put spring seat(644), pilot spring(646) and adjusting ring(Q, 645) into pilot hole.  
Then fix spring seat(624), inner spring (626) and outer spring(625) into compensating hole.  
When fitting spring seat, take care not to mistake direction of spring seat.

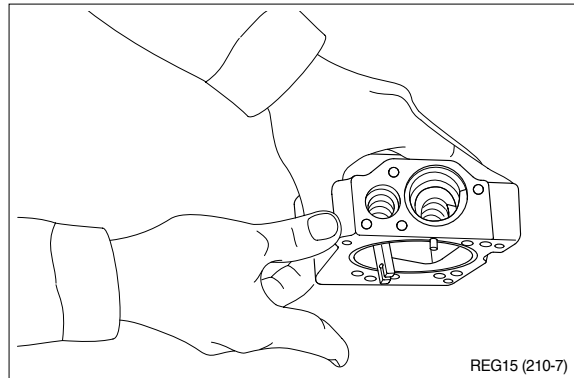

- (13) Install cover(C, 629) fitted with adjusting screws(628, 925), adjusting ring(C, 627), lock nut(630), hexagon nut(801) and adjusting screw(924).  
Then tighten them with hexagonal socket head screws(438).

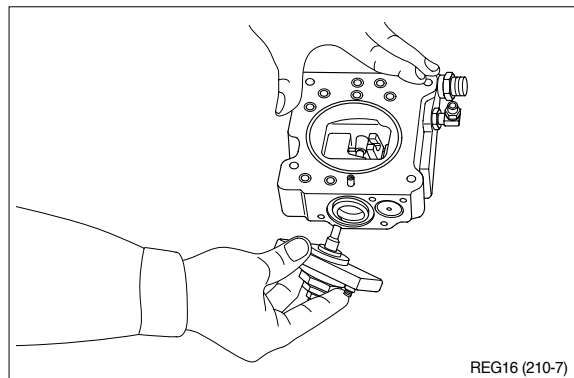

This completes assembling.