

GROUP 13 BOOM, ARM, BUCKET, DOZER AND OUTRIGGER CYLINDER

1. REMOVAL AND INSTALL

1) BUCKET CYLINDER

(1) Removal

Expand the arm and bucket fully, lower the work equipment to the ground and stop the engine.

Operate the control levers and pedals several times to release the remaining pressure in the hydraulic piping.

⚠ Loosen the breather slowly to release the pressure inside the hydraulic tank.

Escaping fluid under pressure can penetrate the skin causing serious injury. Fit blind plugs in the hoses after disconnecting them, to prevent dirt or dust from entering.

Set block between bucket cylinder and arm.

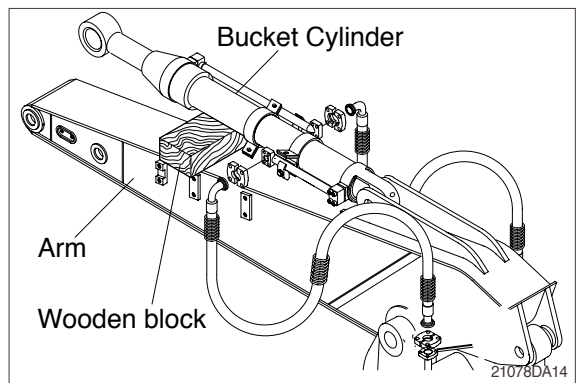

Remove bolt(2), nut(3) and pull out pin (1).

Tie the rod with wire to prevent it from coming out.

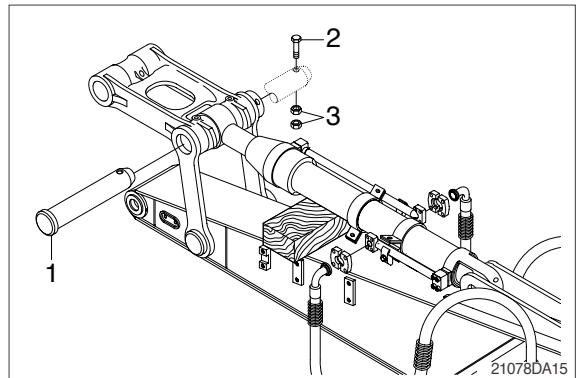

Disconnect bucket cylinder hoses(4) and put plugs(5) on cylinder pipe.

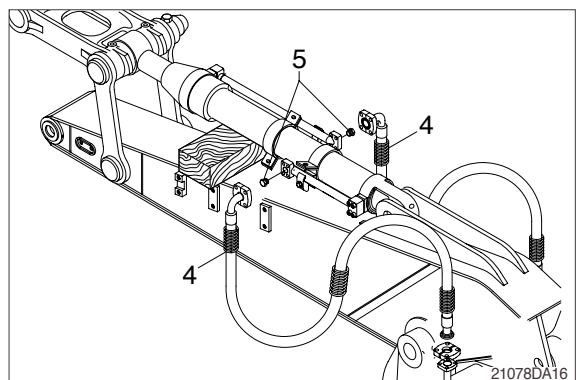

Sling bucket cylinder assembly(8) and remove bolt(6) then pull out pin (5).
Remove bucket cylinder assembly(8).
· Weight : 180kg(400lb)

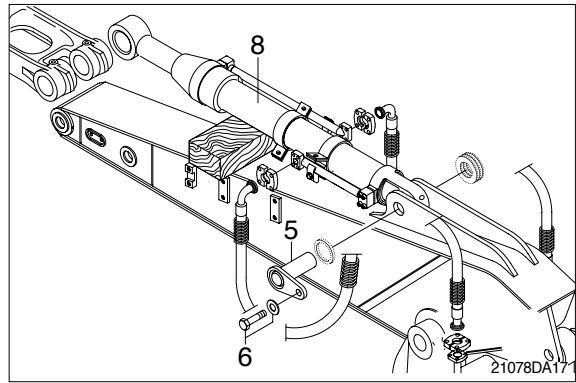

(2) Install

Carry out installation in the reverse order to removal.

- ⚠ When aligning the mounting position of the pin, do not insert your fingers in the pin hole.

Bleed the air from the bucket cylinder.

Confirm the hydraulic oil level and check the hydraulic oil leak or not.

2) ARM CYLINDER

(1) Removal

Expand the arm and bucket fully, lower the work equipment to the ground and stop the engine.

Operate the control levers and pedals several times to release the remaining pressure in the hydraulic piping.

⚠ Loosen the breather slowly to release the pressure inside the hydraulic tank.

Escaping fluid under pressure can penetrate the skin causing serious injury.

Fit blind plugs in the hoses after disconnecting them, to prevent dirt or dust from entering.

Set block between arm cylinder and boom.

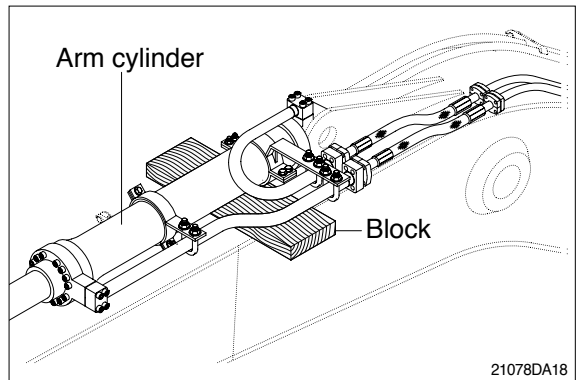

Remove bolt(2) and pull out pin(1).

Tie the rod with wire to prevent it from coming out.

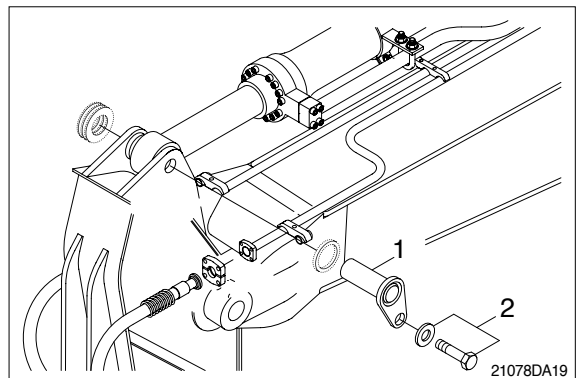

Disconnect arm cylinder hoses(4) and put plugs on cylinder pipe.

Disconnect greasing pipings(5).

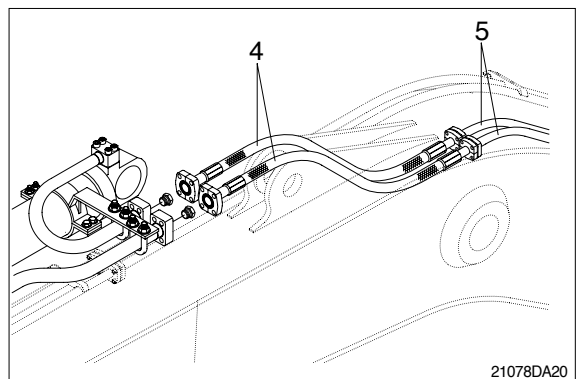

Sling arm assembly(8) and remove bolt (7) then pull out pin(6).
Remove arm cylinder assembly(8).
· Weight : 290kg(640lb)

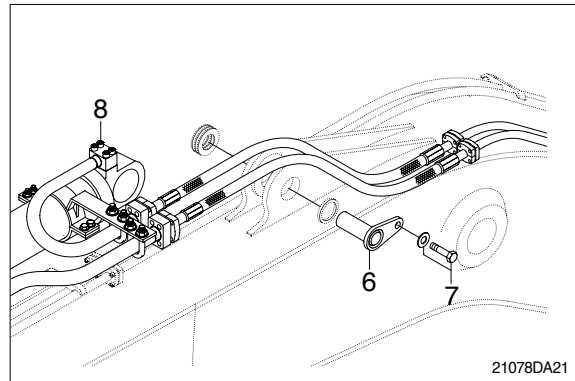

(2) Install

Carry out installation in the reverse order to removal.

- ⚠ When aligning the mounting position of the pin, do not insert your fingers in the pin hole.

Bleed the air from the arm cylinder.

Confirm the hydraulic oil level and check the hydraulic oil leak or not.

3) BOOM CYLINDER

(1) Removal

Expand the arm and bucket fully, lower the work equipment to the ground and stop the engine.

Operate the control levers and pedals several times to release the remaining pressure in the hydraulic piping.

⚠ Loosen the breather slowly to release the pressure inside the hydraulic tank.

Escaping fluid under pressure can penetrate the skin causing serious injury.

Fit blind plugs in the hoses after disconnecting them, to prevent dirt or dust from entering.

Disconnect greasing hoses(1).

Sling boom cylinder assembly.

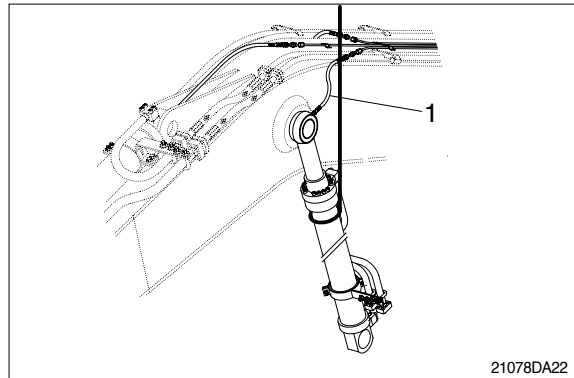

Remove bolt(4), stop plate(5) and pull out pin(2).

Tie the rod with wire to prevent it from coming out.

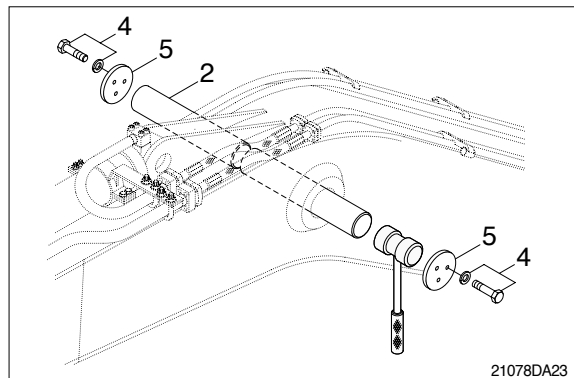

Lower the boom cylinder assembly(6) on a stand.

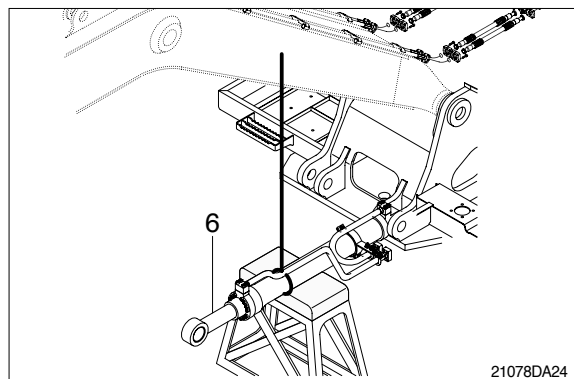

Disconnect boom cylinder hoses(7) and put plugs on cylinder pipe.

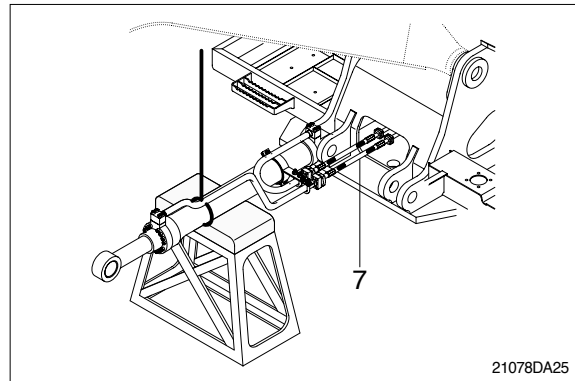

Remove bolt(9) and pull out pin(8).
Remove boom cylinder assembly(6).
· Weight : 190kg(420lb)

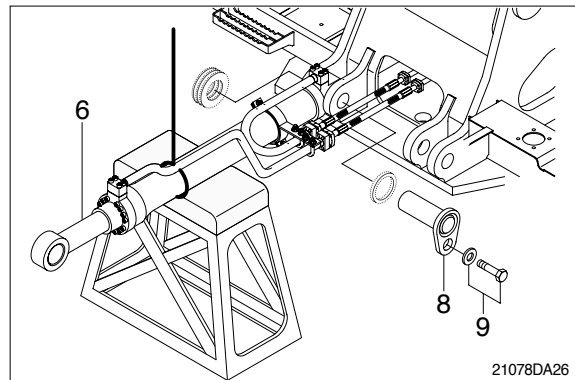

(2) Install

Carry out installation in the reverse order to removal.

▲ When aligning the mounting position of the pin, do not insert your fingers in the pin hole.

Bleed the air from the boom cylinder.

Confirmed the hydraulic oil level and check the hydraulic oil leak or not.

4) DOZER CYLINDER

(1) Removal

Expand the arm and bucket fully, lower the work equipment to the ground and stop the engine.

Operate the control levers and pedals several times to release the remaining pressure in the hydraulic piping.

Loosen the breather slowly to release the pressure inside the hydraulic tank.

⚠ Escaping fluid under pressure can penetrate the skin causing serious injury.

Fit blind plugs in the hoses after disconnecting them, to prevent dirt or dust from entering.

Lower the dozer blade to the ground.

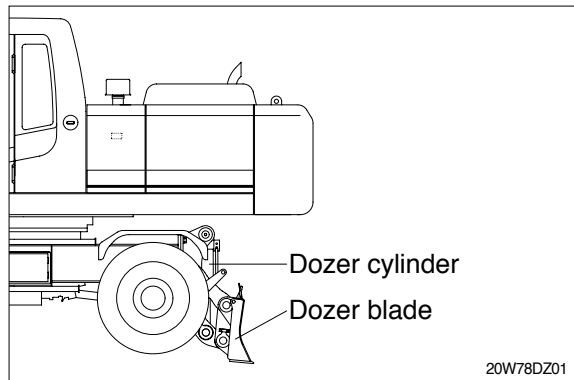

Disconnect dozer cylinder hoses(1), and put plugs on cylinder pipe.

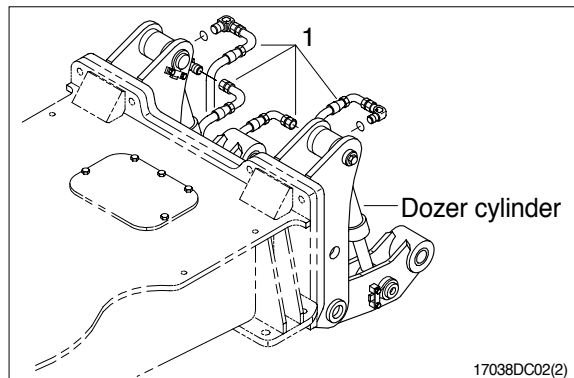

Sling dozer cylinder assembly.
Remove bolt(2) and pull out pin(3).
Tie the rod with wire to prevent it from coming out.

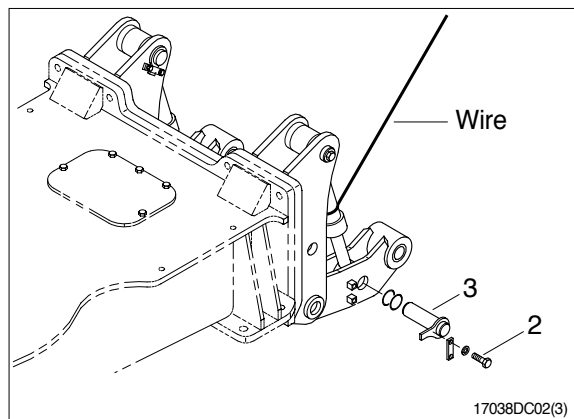

Lower the dozer cylinder rod side on a wooden block.

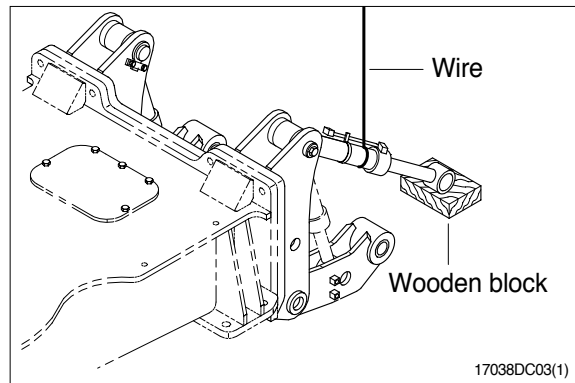

Loosen the bolt(4) and remove lock washer(5), hook plate(6), and spacer(7).
Remove bolt(8) and pull out pin(9).
Remove the dozer cylinder assy(10).
· Weight : 82kg(180lb)

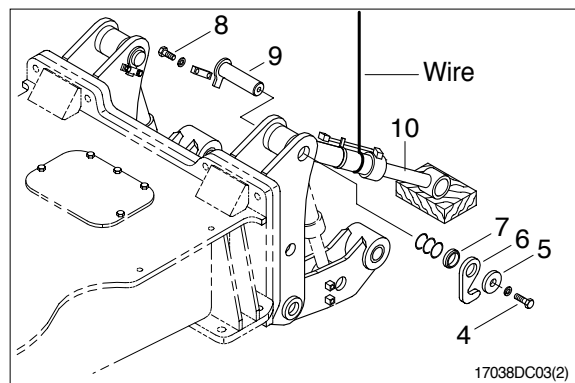

(2) Install

Carry out installation in the reverse order to removal.

▲ When aligning the mounting position of the pin, do not insert your fingers in the pin hole.

Bleed the air from the dozer cylinder.

Confirm the hydraulic oil level and check the hydraulic oil leak or not.

2. DISASSEMBLY AND ASSEMBLY

1) STRUCTURE

(1) Bucket cylinder

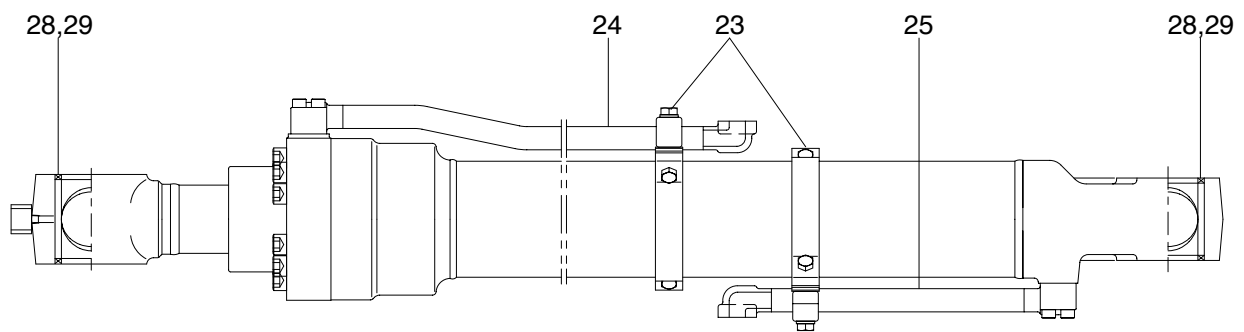
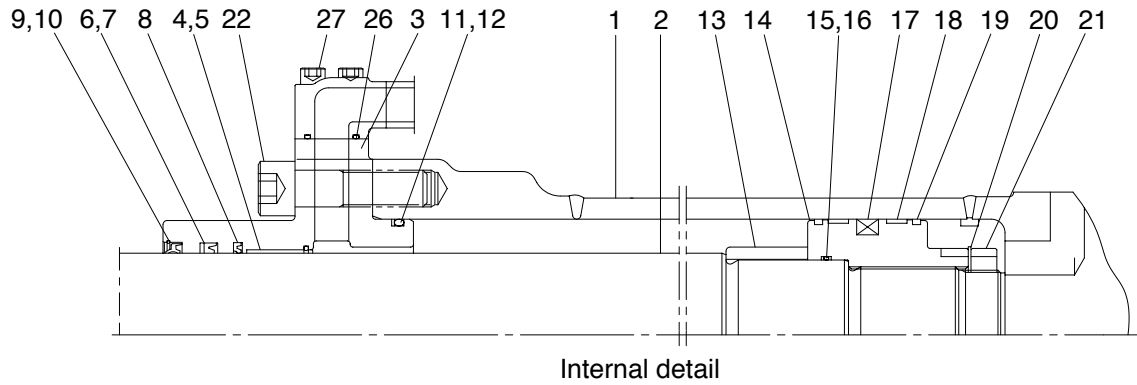

21078DA27

1	Tube assembly	11	O-ring	21	Lock nut
2	Rod assembly	12	Back up ring	22	Hexagon socket head bolt
3	Gland	13	Cushion ring	23	Band assembly
4	DD2 bushing	14	Piston	24	Pipe assembly(R)
5	Snap ring	15	O-ring	25	Pipe assembly(B)
6	Rod seal	16	Back up ring	26	O-ring
7	Back up ring	17	Piston seal	27	Hexagon socket head bolt
8	Buffer ring	18	Wear ring	28	Pin bushing
9	Dust wiper	19	Dust ring	29	Dust seal
10	Snap ring	20	Lock washer		

(2) Arm cylinder

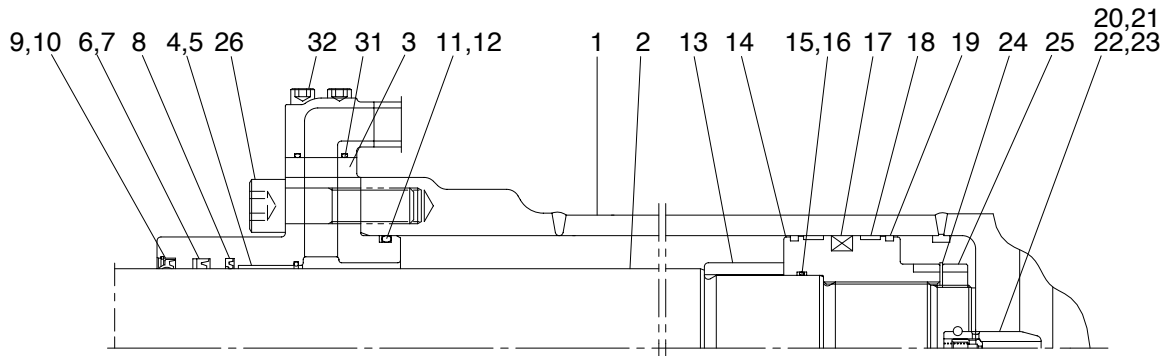

Internal detail

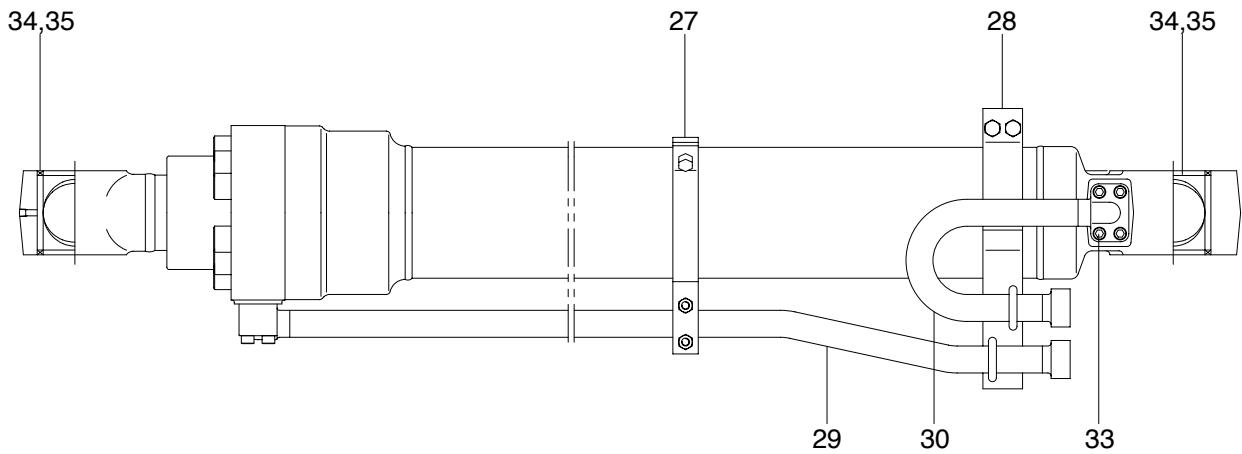

21078DA28

- | | | | | | |
|----|---------------|----|---------------|----|--------------------------|
| 1 | Tube assembly | 13 | Cushion ring | 25 | Lock nut |
| 2 | Rod assembly | 14 | Piston | 26 | Hexagon socket head bolt |
| 3 | Gland | 15 | O-ring | 27 | Band assembly(R) |
| 4 | DD2 bushing | 16 | Back up ring | 28 | Band assembly(B) |
| 5 | Snap ring | 17 | Piston seal | 29 | Pipe assembly(R) |
| 6 | Rod seal | 18 | Wear ring | 30 | Pipe assembly(B) |
| 7 | Back up ring | 19 | Dust ring | 31 | O-ring |
| 8 | Buffer ring | 20 | Cushion spear | 32 | Hexagon socket head bolt |
| 9 | Dust wiper | 21 | Check valve | 33 | Hexagon socket head bolt |
| 10 | Snap ring | 22 | Coil spring | 34 | Pin bushing |
| 11 | O-ring | 23 | Stop ring | 35 | Dust seal |
| 12 | Back up ring | 24 | Lock washer | | |

(3) Boom cylinder

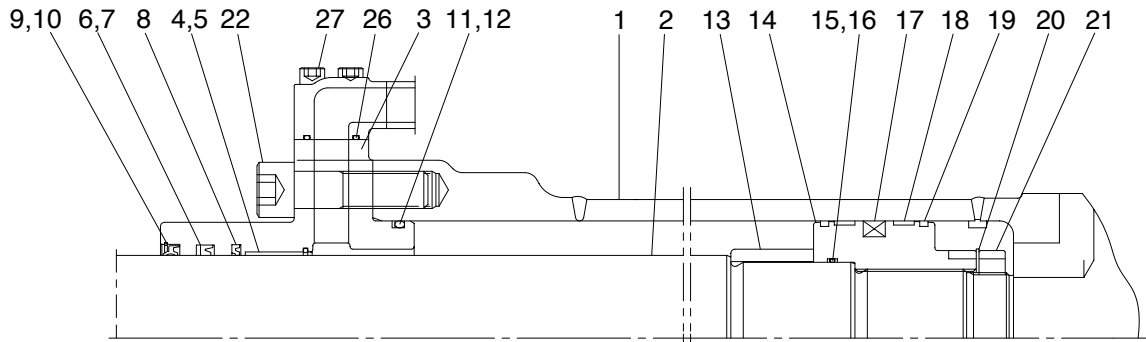

Internal detail

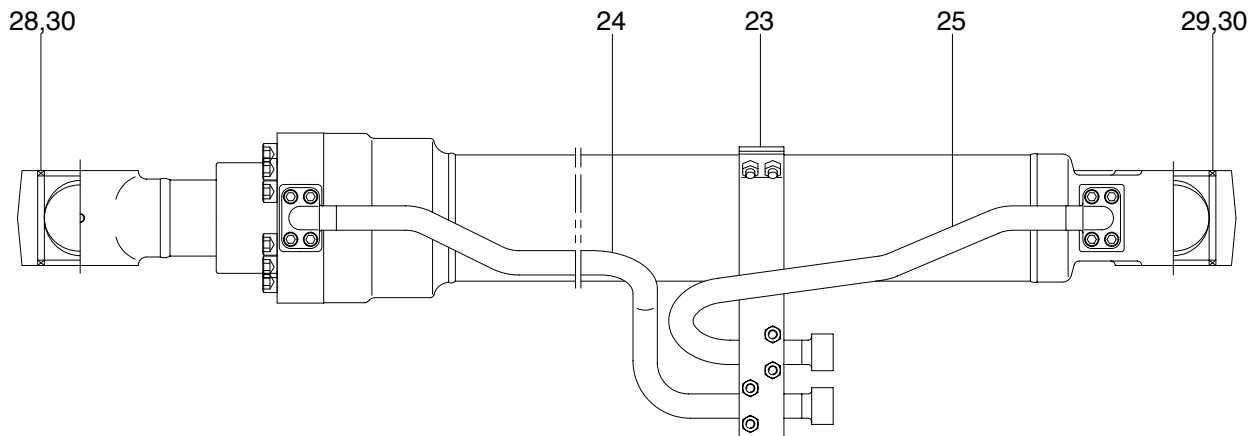

21078DA29

- | | | | | | |
|----|---------------|----|--------------|----|--------------------------|
| 1 | Tube assembly | 11 | O-ring | 21 | Lock nut |
| 2 | Rod assembly | 12 | Back up ring | 22 | Hexagon socket head bolt |
| 3 | Gland | 13 | Cushion ring | 23 | Band assembly |
| 4 | DD2 bushing | 14 | Piston | 24 | Pipe assembly(R) |
| 5 | Snap ring | 15 | O-ring | 25 | Pipe assembly(B) |
| 6 | Rod seal | 16 | Back up ring | 26 | O-ring |
| 7 | Back up ring | 17 | Piston seal | 27 | Hexagon socket head bolt |
| 8 | Buffer ring | 18 | Wear ring | 28 | Pin bushing |
| 9 | Dust wiper | 19 | Dust ring | 29 | Pin bushing |
| 10 | Snap ring | 20 | Lock washer | 30 | Dust seal |

(4) Dozer cylinder

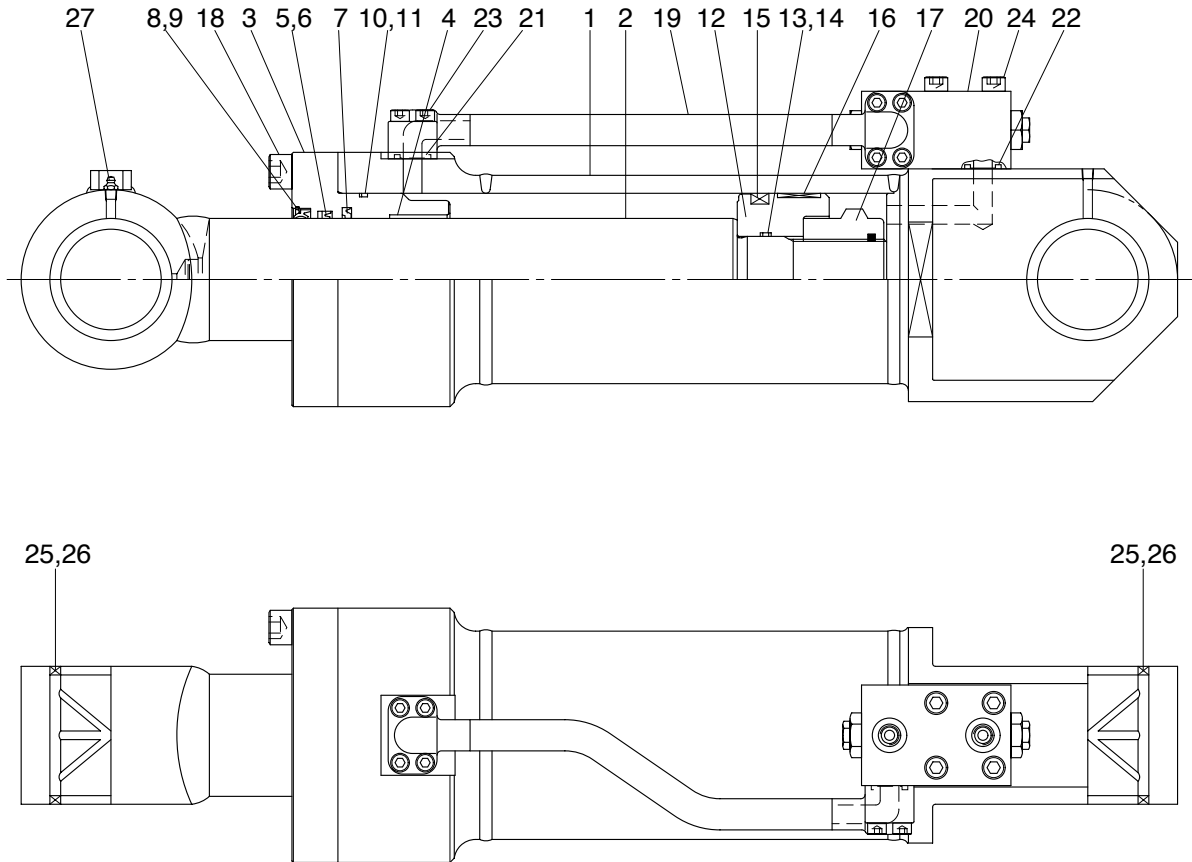

200W38DC00

- | | | | | | |
|---|---------------|----|--------------------------|----|--------------------------|
| 1 | Tube assembly | 10 | O-ring | 19 | Pipe assembly |
| 2 | Rod assembly | 11 | Back up ring | 20 | Check valve block |
| 3 | Gland | 12 | Piston | 21 | O-ring |
| 4 | Du bushing | 13 | O-ring | 22 | O-ring |
| 5 | Rod seal | 14 | Back up ring | 23 | Hexagon socket head bolt |
| 6 | Back up ring | 15 | Piston seal | 24 | Hexagon socket head bolt |
| 7 | Buffer ring | 16 | Wear ring | 25 | Pin bushing |
| 8 | Dust wiper | 17 | Nylon nut | 26 | Dust seal |
| 9 | Snap ring | 18 | Hexagon socket head bolt | 27 | Grease nipple |

(5) Outrigger cylinder

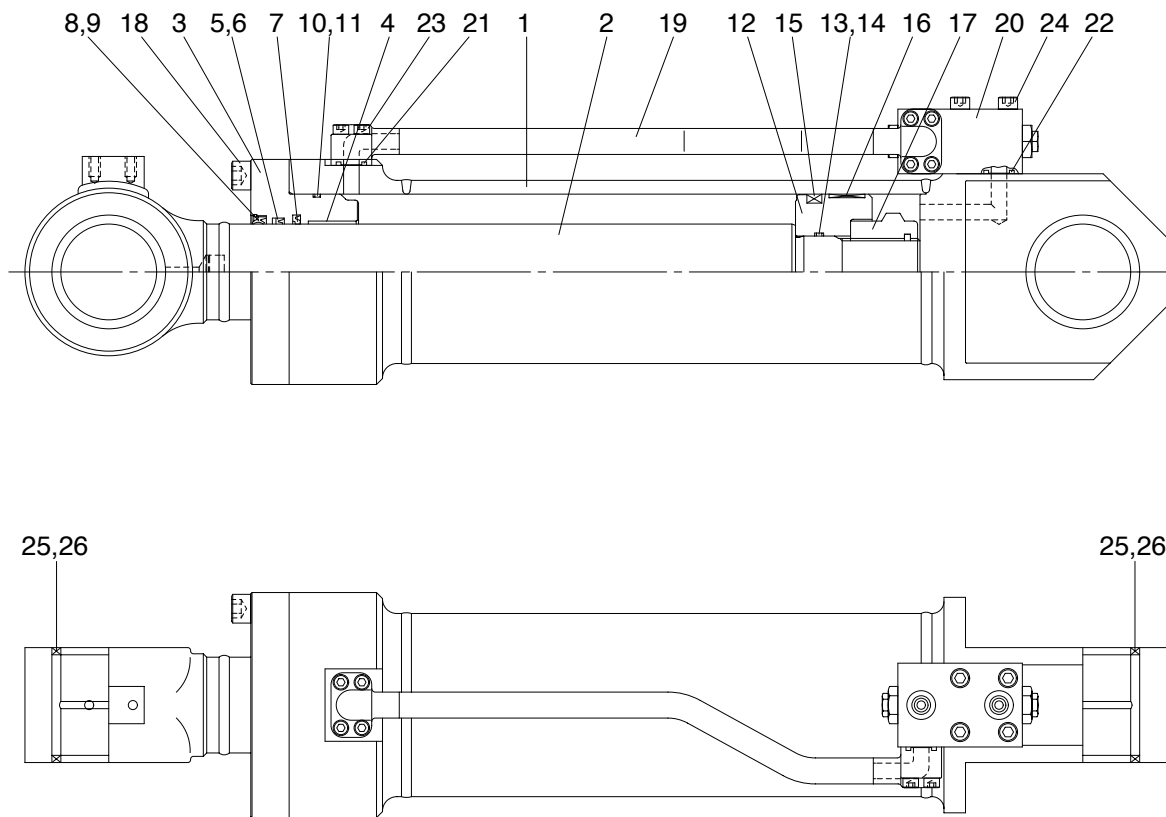

20W780T01

- | | | | | | |
|---|---------------|----|--------------------------|----|--------------------------|
| 1 | Tube assembly | 10 | O-ring | 19 | Pipe assembly |
| 2 | Rod assembly | 11 | Back up ring | 20 | Check valve block |
| 3 | Gland | 12 | Piston | 21 | O-ring |
| 4 | Du bushing | 13 | O-ring | 22 | O-ring |
| 5 | Rod seal | 14 | Back up ring | 23 | Hexagon socket head bolt |
| 6 | Back up ring | 15 | Piston seal | 24 | Hexagon socket head bolt |
| 7 | Buffer ring | 16 | Wear ring | 25 | Pin bushing |
| 8 | Dust wiper | 17 | Nylon nut | 26 | Dust seal |
| 9 | Snap ring | 18 | Hexagon socket head bolt | | |

2) TOOLS AND TIGHTENING TORQUE

(1) Tools

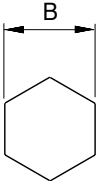
Allen wrench	6		
	8		
	14		
	17		
Spanner	7		
	8		
(-) Driver	Small and large sizes		
Torque wrench	Capable of tightening with the specified torques		

(2) Tightening torque

Part name		Item	Size	Torque	
				kgf · m	lbf · ft
Socket head bolt	Bucket cylinder	22	M16	23 ± 2.0	166 ± 14.5
	Boom cylinder		M16	23 ± 2.0	166 ± 14.5
	Arm cylinder	26	M18	32 ± 3.0	232 ± 21.7
	Dozer cylinder	18	M16	23 ± 2.0	166 ± 14.5
	Outrigger cylinder				
	Bucket cylinder	27	M10	5.4 ± 0.5	39.1 ± 3.6
	Boom cylinder	27			
	Arm cylinder	33			
	Dozer cylinder	23	M8	2.7 ± 0.3	19.5 ± 2.2
	Outrigger cylinder				
	Dozer cylinder	24	M10	5.4 ± 0.5	39.1 ± 3.6
	Outrigger cylinder				
Hexagon head bolt	Bucket	26	M10	3.2 ± 0.3	23.1 ± 2.2
	Boom	25			
	Arm	29			
Lock nut	Bucket cylinder	21	M60	100 ± 10.0	723 ± 72.3
	Boom cylinder	21	M60		
	Arm cylinder	25	M70		
	Dozer cylinder	17	M56	400 ± 40	2893 ± 289
	Outrigger cylinder		M52	300 ± 30	2170 ± 217
Piston	Bucket cylinder	14	-	150 ± 15.0	1085 ± 109
	Boom cylinder				
	Arm cylinder				
	Dozer cylinder	12		100 ± 10	723.3 ± 72.3
	Outrigger cylinder				

3) DISASSEMBLY

(1) Remove cylinder head and piston rod

Hold the clevis section of the tube in a vise.

Use mouth pieces so as not to damage the machined surface of the cylinder tube. Do not make use of the outside piping as a locking means.

Pull out rod assembly(2) about 200mm (7.1in). Because the rod assembly is rather heavy, finish extending it with air pressure after the oil draining operation.

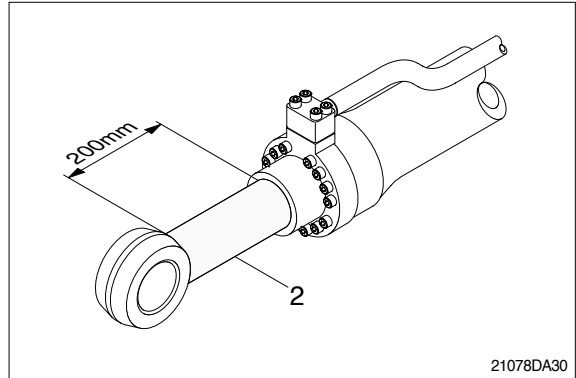

Loosen and remove socket bolts(22) of the gland in sequence.

Cover the extracted rod assembly(2) with rag to prevent it from being accidentally damaged during operation.

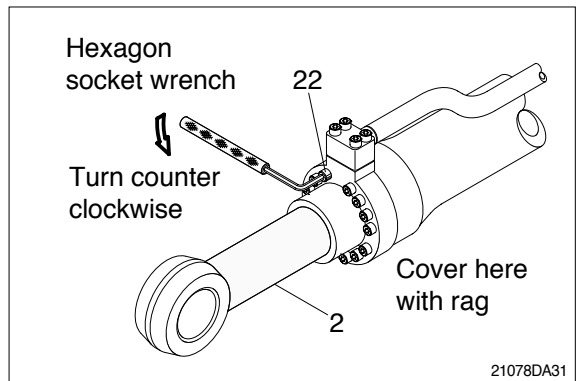

Draw out cylinder head and rod assembly together from tube assembly(1).

Since the rod assembly is heavy in this case, lift the tip of the rod assembly(2) with a crane or some means and draw it out. However, when rod assembly(2) has been drawn out to approximately two thirds of its length, lift it in its center to draw it completely.

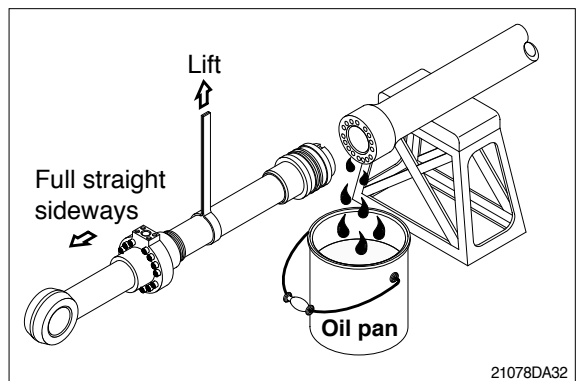

Note that the plated surface of rod assembly(2) is to be lifted. For this reason, do not use a wire sling and others that may damage it, but use a strong cloth belt or a rope.

Place the removed rod assembly on a wooden V-block that is set level. Cover a V-block with soft rag.

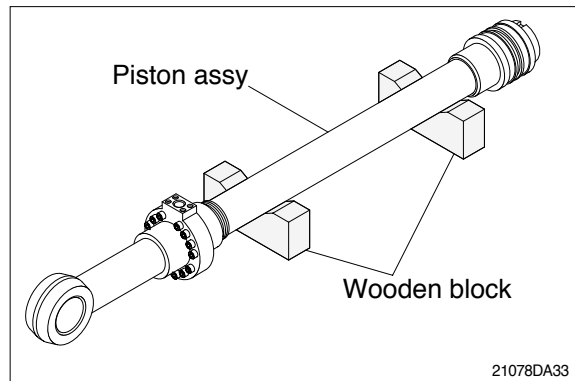

(2) Remove piston and cylinder head

Remove lock nut(21).
 Since lock nut(21) and lock washer(22) is tightened to a high torque, use a hydraulic and power wrench that utilizes a hydraulic cylinder, to remove the lock nut(21) and lock washer (22).
 Remove piston assembly(14), back up ring(16), and O-ring(15).

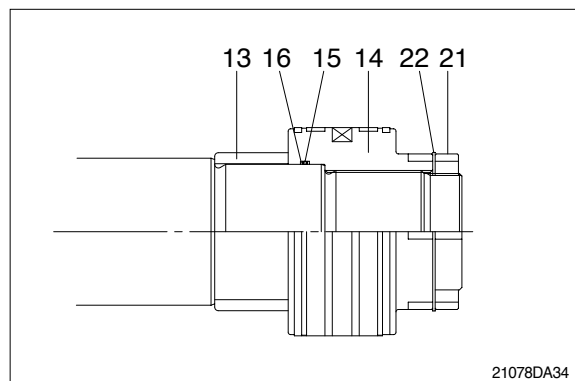

Remove the cylinder head assembly from rod assembly(2).
 If it is too heavy to move, move it by striking the flanged part of cylinder head with a plastic hammer.
 Pull it straight with cylinder head assembly lifted with a crane.
 Exercise care so as not to damage the lip of rod bushing(4) and packing (5,6,7,8,9,10) by the threads of rod assembly(2).

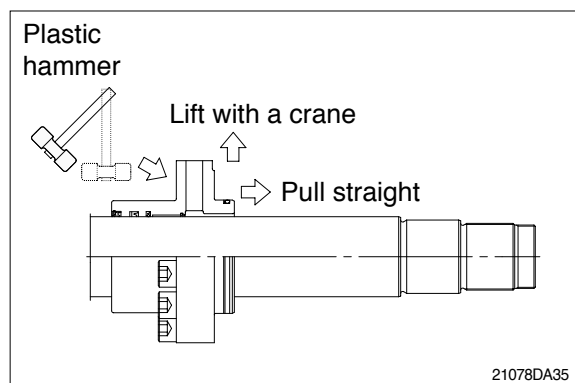

(3) Disassemble the piston assembly

Remove wear ring(18).

Remove dust ring(19) and piston seal (17).

Exercise care in this operation not to damage the grooves.

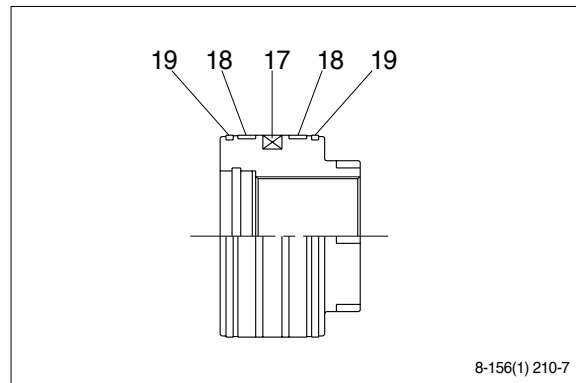

(4) Disassemble cylinder head assembly

Remove back up ring(12) and O-ring (11).

Remove snap ring(10), dust wiper(9).

Remove back up ring(7), rod seal(6) and buffer ring(8).

Exercise care in this operation not to damage the grooves.

Do not remove seal and ring, if does not damaged.

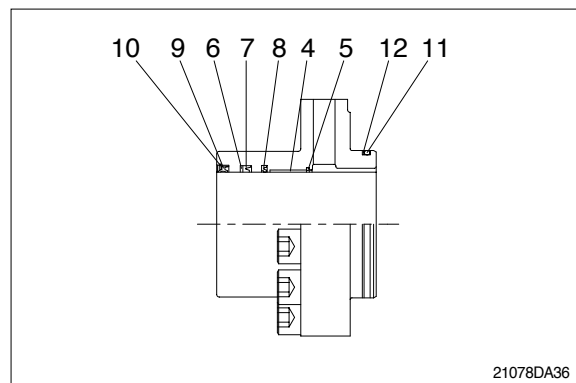

3) ASSEMBLY

(1) Assemble cylinder head assembly

Check for scratches or rough surfaces if found smooth with an oil stone.

Coat the inner face of gland(3) with hydraulic oil.

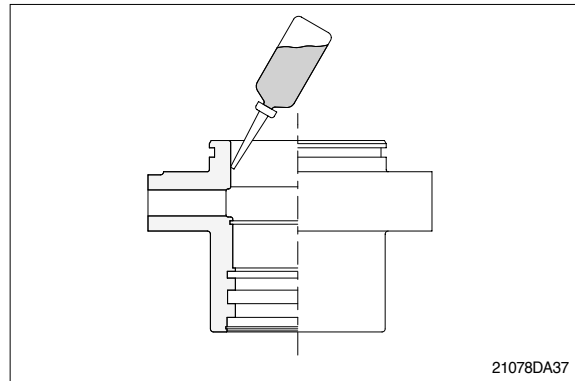

Coat dust wiper(9) with grease and fit dust wiper(9) to the bottom of the hole of dust seal.

At this time, press a pad metal to the metal ring of dust seal.

Fit snap ring(10) to the stop face.

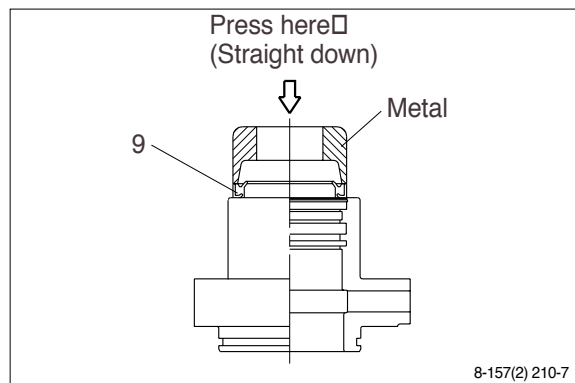

Fit back up ring(7), rod seal(6) and buffer ring(8) to corresponding grooves, in that order.

Coat each packing with hydraulic oil before fitting it.

Insert the backup ring until one side of it is inserted into groove.

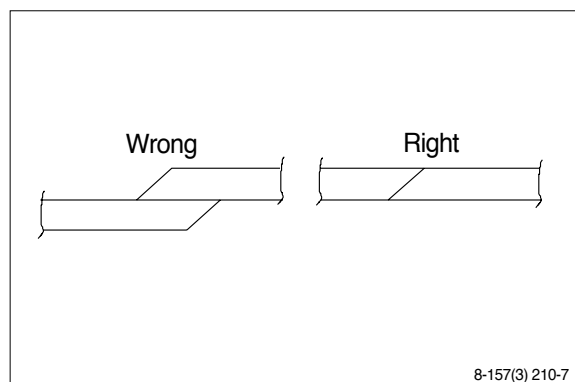

Rod seal(6) has its own fitting direction. Therefore, confirm it before fitting them. Fitting rod seal(6) upside down may damage its lip. Therefore check the correct direction that is shown in fig.

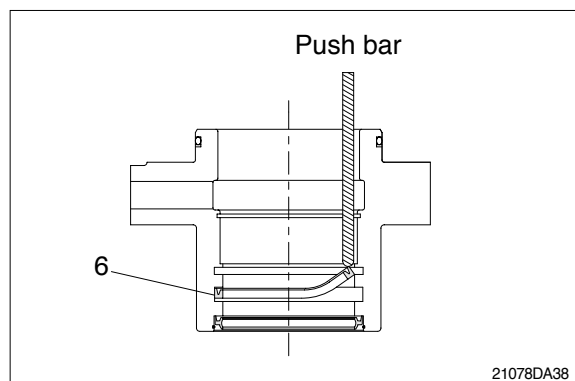

Fit back up ring(12) to gland(3).
 Put the backup ring in the warm water of 30~50,C.
 Fit O-ring(11) to gland(3).

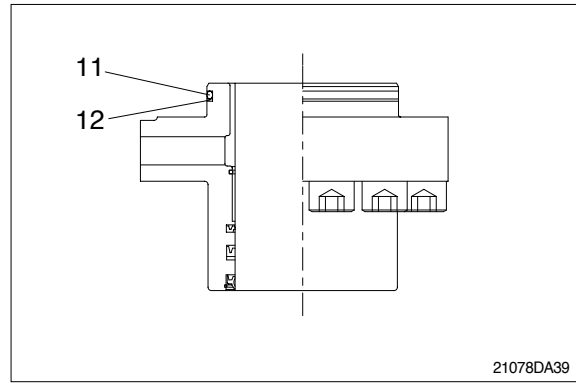

(2) Assemble piston assembly

Check for scratches or rough surfaces.
 If found smooth with an oil stone.
 Coat the outer face of piston(14) with hydraulic oil.

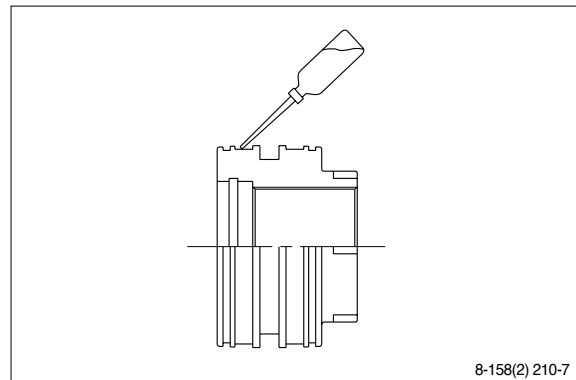

Fit piston seal(17) to piston.
 Put the piston seal in the warm water of 60~100,C for more than 5 minutes.
 After assembling the piston seal, press its outer diameter to fit in.

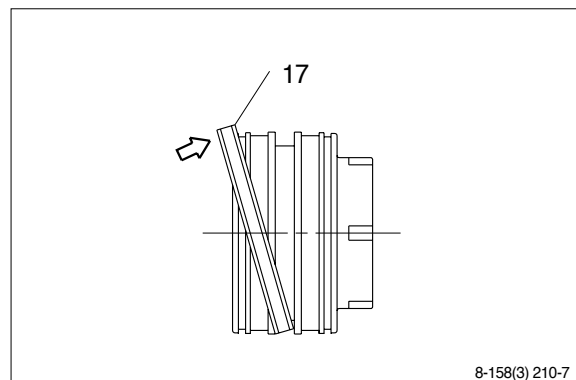

Fit wear ring(18) and dust ring(19) to piston(14).

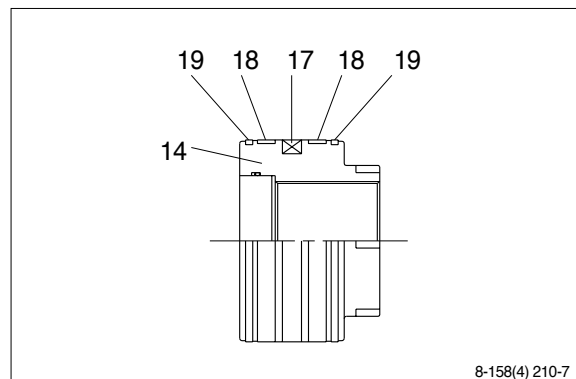

(3) Install piston and cylinder head

Fix the rod assembly to the work bench.
 Apply hydraulic oil to the outer surface of rod assembly(2), the inner surface of piston and cylinder head.
 Insert cylinder head assembly to rod assembly.

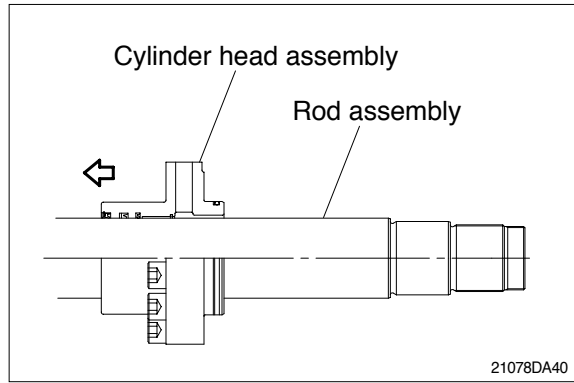

Insert cushion ring(13) to rod assembly.
 Note that cushion ring(13) has a direction in which it should be fitted.

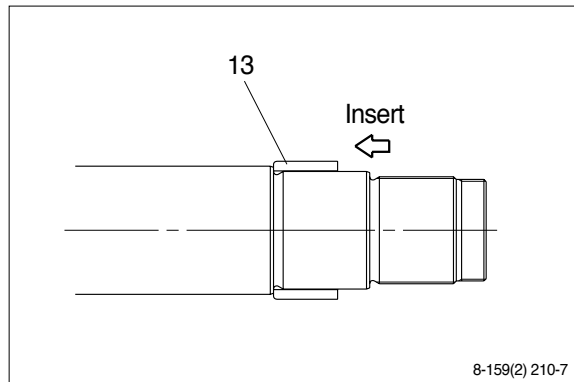

Fit piston assembly to rod assembly.
 · Tightening torque : $100 \pm 10 \text{ kgf} \cdot \text{m}$
 ($723 \pm 72 \text{ lbf} \cdot \text{ft}$)

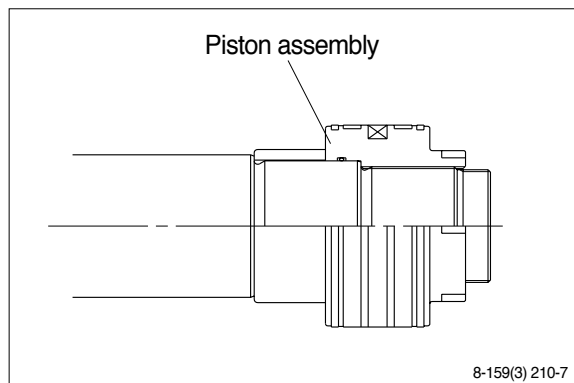

Fit lock nut to piston.
 · Tightening torque :

Item		kgf · m	lbf · ft
Bucket	21	100 ± 10	723 ± 72.3
Boom	21	100 ± 10	723 ± 72.3
Arm	25	100 ± 10	723 ± 72.3
Dozer	17	400 ± 40	2893 ± 289
Outrigger	17	300 ± 30	2170 ± 217

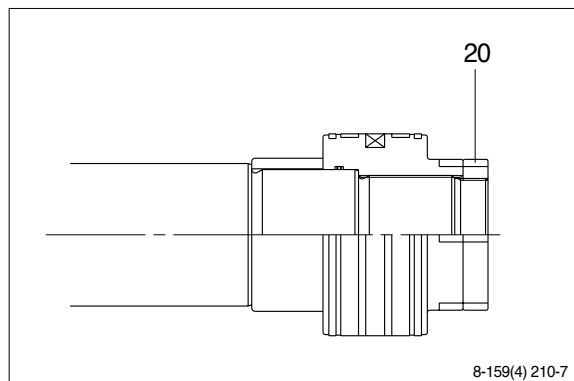

(3) Overall assemble

Place a V-block on a rigid work bench.
Mount the tube assembly(1) on it and fix the assembly by passing a bar through the clevis pin hole to lock the assembly.
Insert the rod assembly in to the tube assembly, while lifting and moving the rod assembly with a crane.
Be careful not to damage piston seal by thread of tube assembly.
Match the bolt holes in the cylinder head flange to the tapped holes in the tube assembly and tighten socket bolts to a specified torque.
Refer to the table of tightening torque.

