

GROUP 12 TURNING JOINT

1. REMOVAL AND INSTALL

1) REMOVAL

- (1) Lower the work equipment to the ground and stop the engine.
- (2) Operate the control levers and pedals several times to release the remaining pressure in the hydraulic piping.
- (3) Loosen the breather slowly to release the pressure inside the hydraulic tank.
- ▲ Escaping fluid under pressure can penetrate the skin causing serious injury. When pipes and hoses are disconnected, the oil inside the piping will flow out, so catch it in oil pan.
- (4) Disconnect all hoses.
- (5) Sling the turning joint assembly (1) and remove the mounting bolt(2).
 - Weight : 100kg(220lb)
 - Tightening torque : $12.2 \pm 1.3\text{kgf} \cdot \text{m}$
($88.2 \pm 9.4\text{lbf} \cdot \text{ft}$)
- (6) Remove the turning joint assembly.
When removing the turning joint, check that all the hoses have been disconnected.

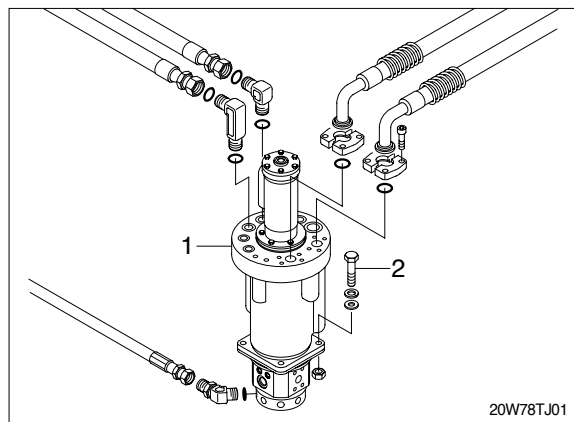

2) INSTALL

- (1) Carry out installation in the reverse order to removal.
Take care of turning joint direction.
Assemble hoses to their original positions.
Confirm the hydraulic oil level and check the hydraulic oil leak or not.

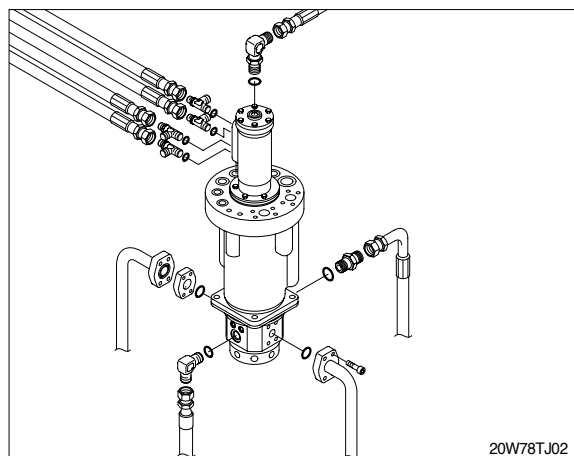

2. DISASSEMBLY AND ASSEMBLY

1) STRUCTURE

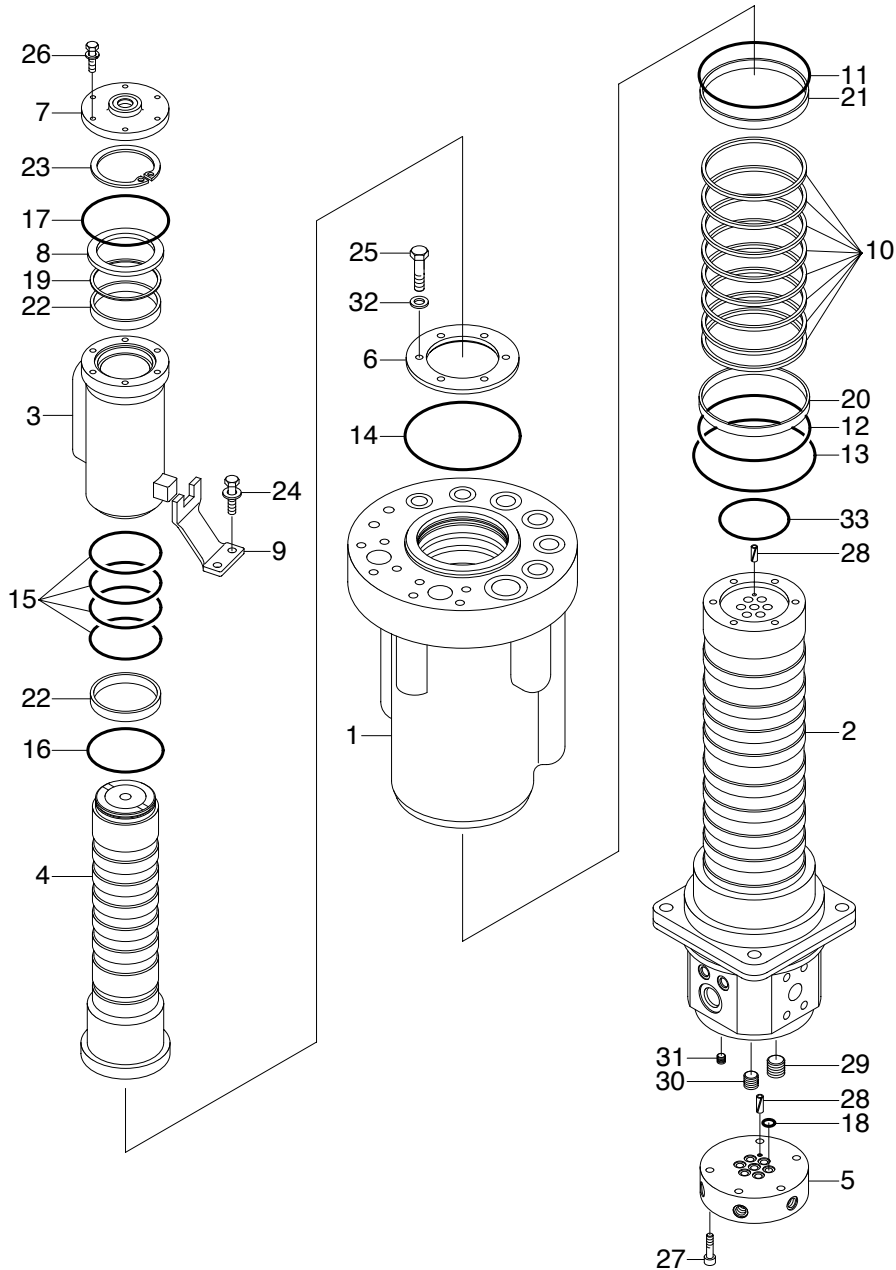

- | | | | | | |
|----|--------------|----|--------------|----|---------------|
| 1 | Main hub | 12 | O-ring | 23 | Retainer ring |
| 2 | Main shaft | 13 | O-ring | 24 | W/washer bolt |
| 3 | Top hub | 14 | O-ring | 25 | Hex bolt |
| 4 | Top shaft | 15 | O-ring | 26 | W/washer bolt |
| 5 | Adaptor | 16 | O-ring | 27 | Socket bolt |
| 6 | Main cover | 17 | O-ring | 28 | Spring pin |
| 7 | Top cover | 18 | O-ring | 29 | Plug |
| 8 | Spacer | 19 | Back up ring | 30 | Plug |
| 9 | Bracket | 20 | Wear ring | 31 | Plug |
| 10 | Slipper seal | 21 | Wear ring | 32 | Plain washer |
| 11 | O-ring | 22 | Wear ring | 33 | O-ring |

20W78TJ03

2) DISASSEMBLY

Before the disassembly, clean the turning joint.

- (1) Loosen the bolt(24) and remove the bracket(9).

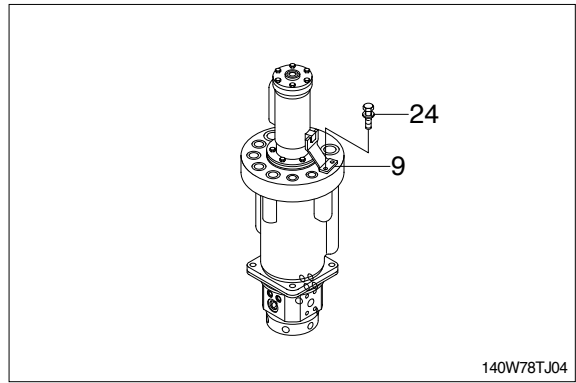

- (2) Loosen the bolt(25) and remove the upside(A) of turning joint. Remove O-ring(14).

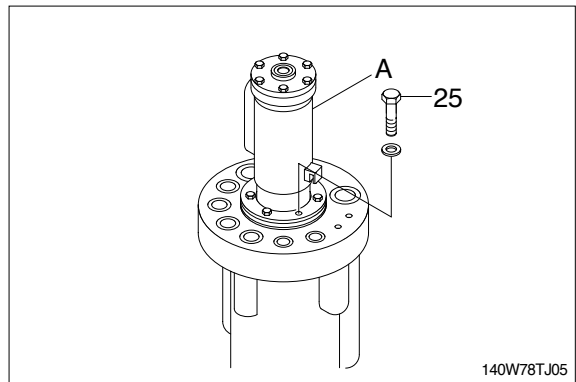

- (3) Loosen the bolt(26) and remove top cover (7).

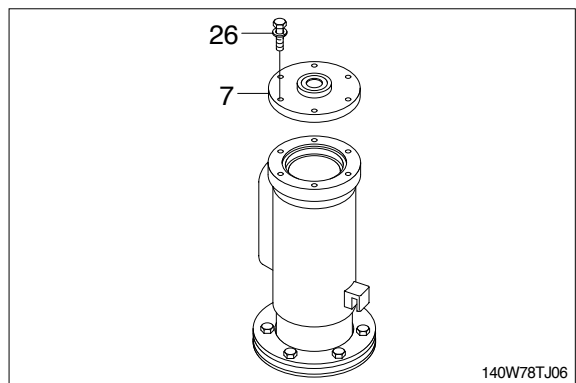

- (4) Remove O-ring(17), retainer ring(23) and spacer(8).

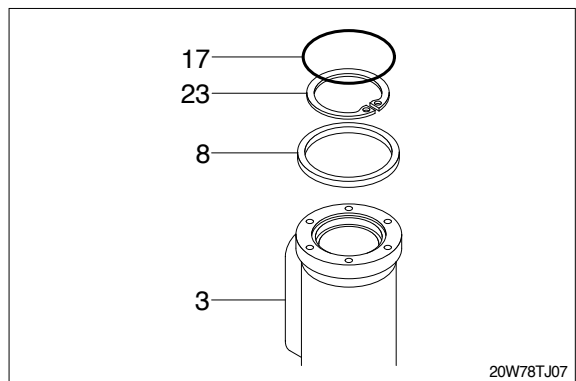

(5) Place hub(3) on a V-block and by using a wood buffer at the shaft end, hit out shaft(4) to about 1/2 from the hub with a hammer.

- ※ Take care not to damage the shaft(4) when remove hub(3) or rest it sideways.
- ※ Put a fitting mark on hub(3) and shaft(4).

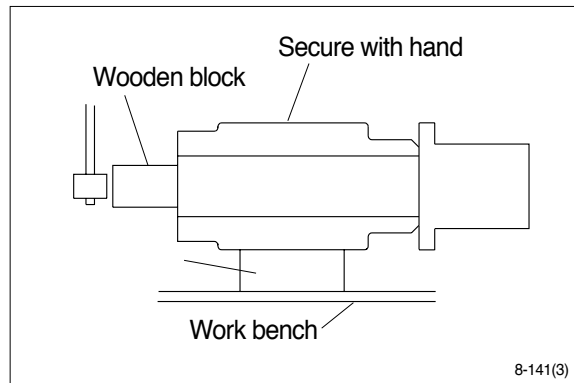

(6) Remove eight O-rings(15), back up ring (19), O-ring(16) and wear ring(22) from hub(3).

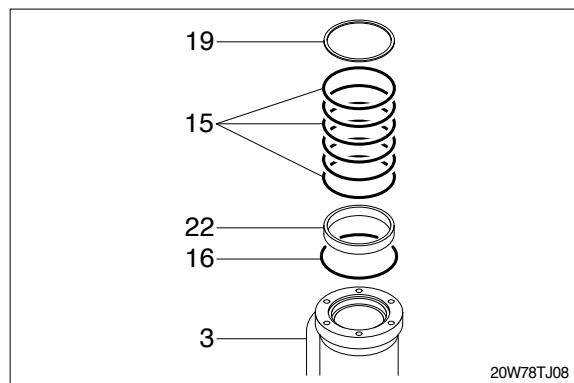

(7) Place main hub(1) on a V-block and by using a wood buffer at the shaft end, hit out main shaft(2) to about 1/2 from the main hub with a hammer.

- ※ Take care not to damage the main shaft(2) when remove main hub(1) or rest it sideways.
- ※ Put a fitting mark on main hub(1) and main shaft(2).

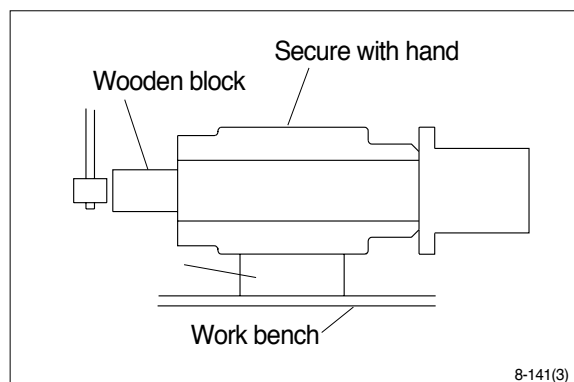

(8) Remove wear ring(21), eight slipper seal(10), O-ring(13) and wear ring(20) from main hub(1).

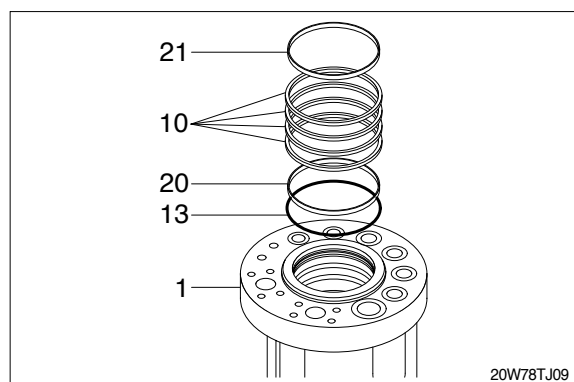

3) ASSEMBLY

Clean all parts.

As a general rule, replace oil seals and O-ring.

Coat the sliding surfaces of all parts with engine oil or grease before installing.

- (1) Fit wear ring(21), eight slipper seal(10), O-ring(13) and wear ring(20).
- (2) Fit O-ring(13) to main shaft(2)

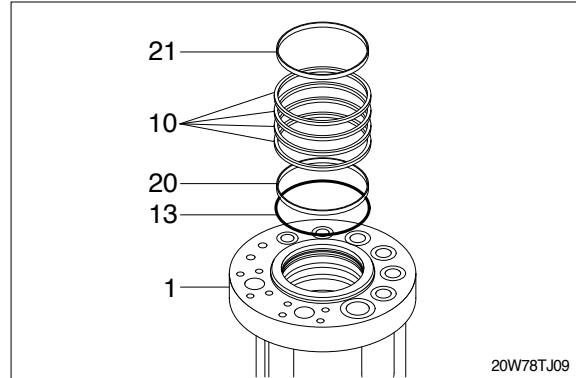

- (3) Set main shaft(2) on block, tap main hub(1) with a plastic hammer to install.

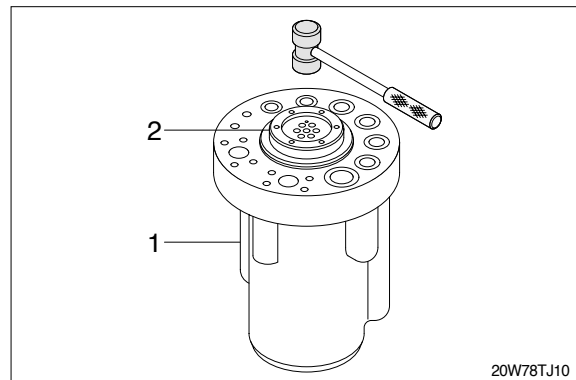

- (4) Fit eight O-ring(15), back up ring(19), O-ring(16) and wear ring(22) to hub(3) of turning joint upside.

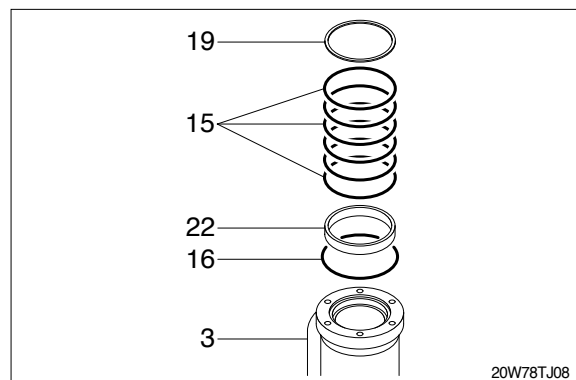

- (5) Set shaft(4) of turning joint upside on block, tap hub(3) with a plastic hammer to install.

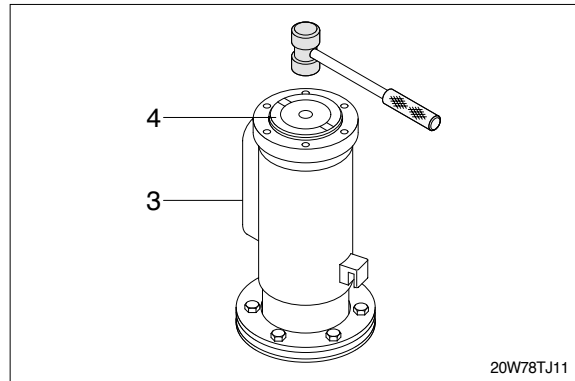

- (6) Fit spacer(8) and retainer ring(23) to shaft(4).
(7) Fit O-ring(17) to hub(3).

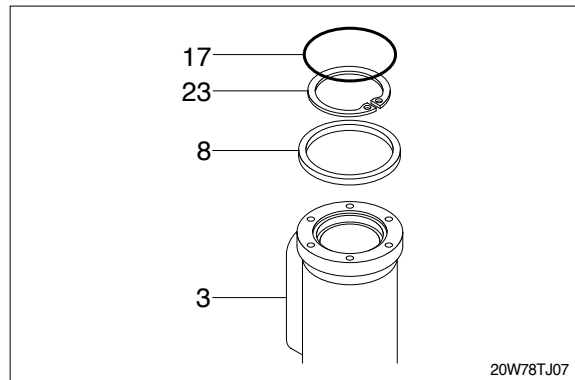

- (8) Set turning joint upside(A) on downside, tighten bolts(25).
· Torque : $3.5 \pm 0.4 \text{ kgf} \cdot \text{m}$

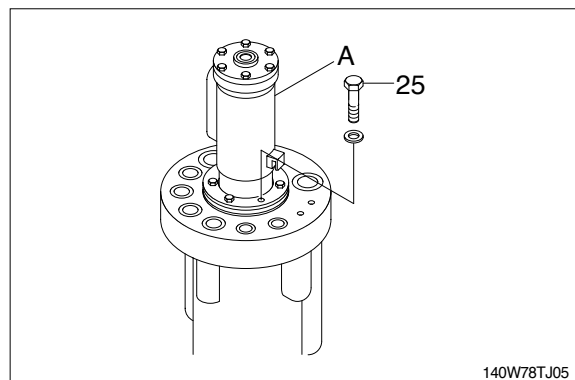

- (9) Fit O-ring(17) to hub(3).
(10) Install cover(7) to hub and tighten bolts(26).
· Torque : $2.35 \pm 0.35 \text{ kgf} \cdot \text{m}$

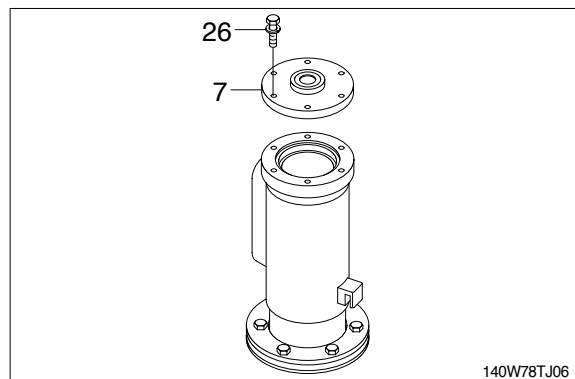

- (11) Install bracket(9) to hub and tighten bolts (24).
· Torque : $5.5 \pm 0.6 \text{kgf} \cdot \text{m}$

This completes assembling

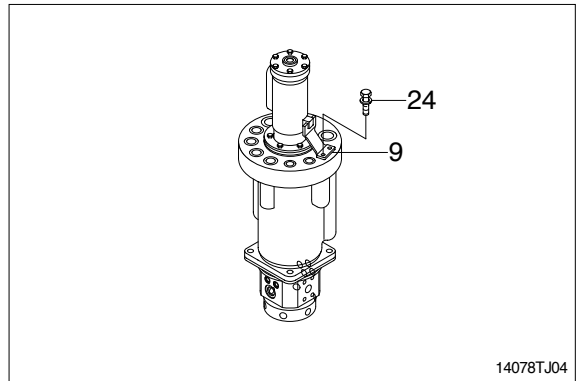

14078TJ04