

# GROUP 4 TRAVEL MOTOR

## 1. CONSTRUCTION

Travel motor consists motor unit, regulator and counter balance valve.

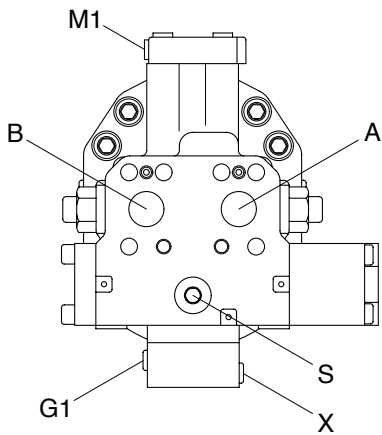
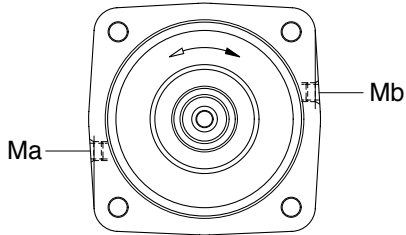
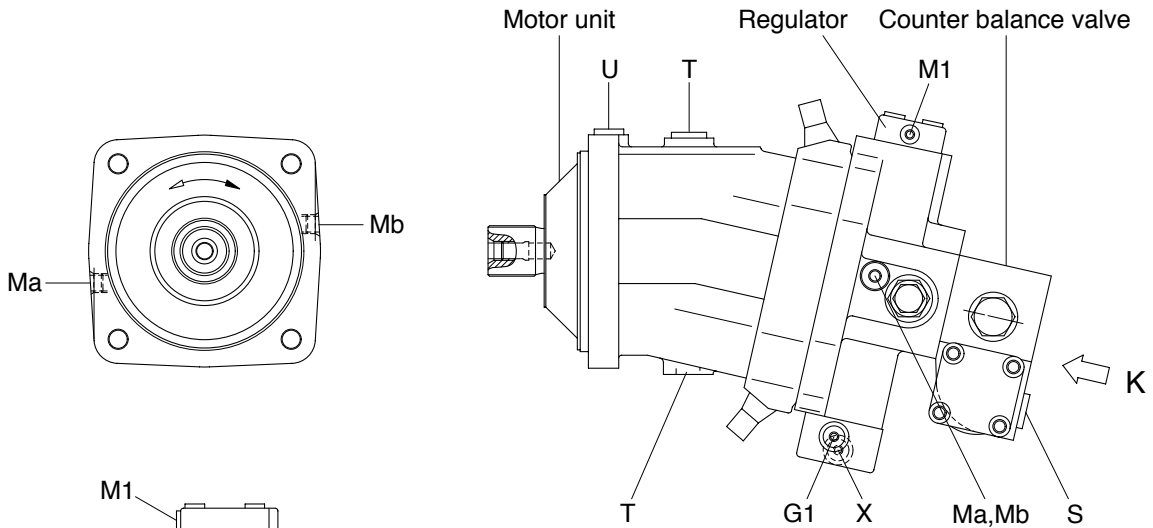

VIEW K

Port	Port name	Port size
A, B	Main port	SAE 6000psi 1 1/4"
G1	Gauge port	M14 × 1.5
M1	Gauge port	M14 × 1.5
X	Gauge port	M14 × 1.5
T	Drain port	M26 × 1.5
U	Gauge port	M22 × 1.5
S	Make up port	M27 × 2.0
Ma, Mb	Gauge port	M18 × 1.5

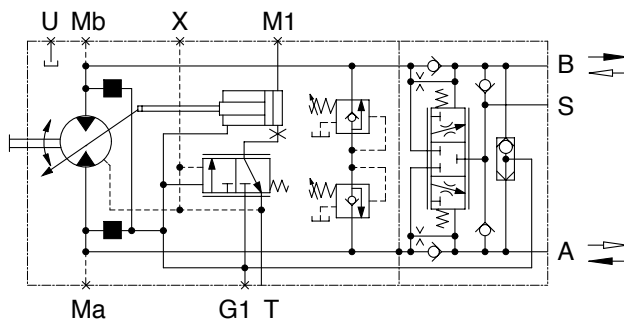

Hydraulic circuit

## 1) MOTOR UNIT

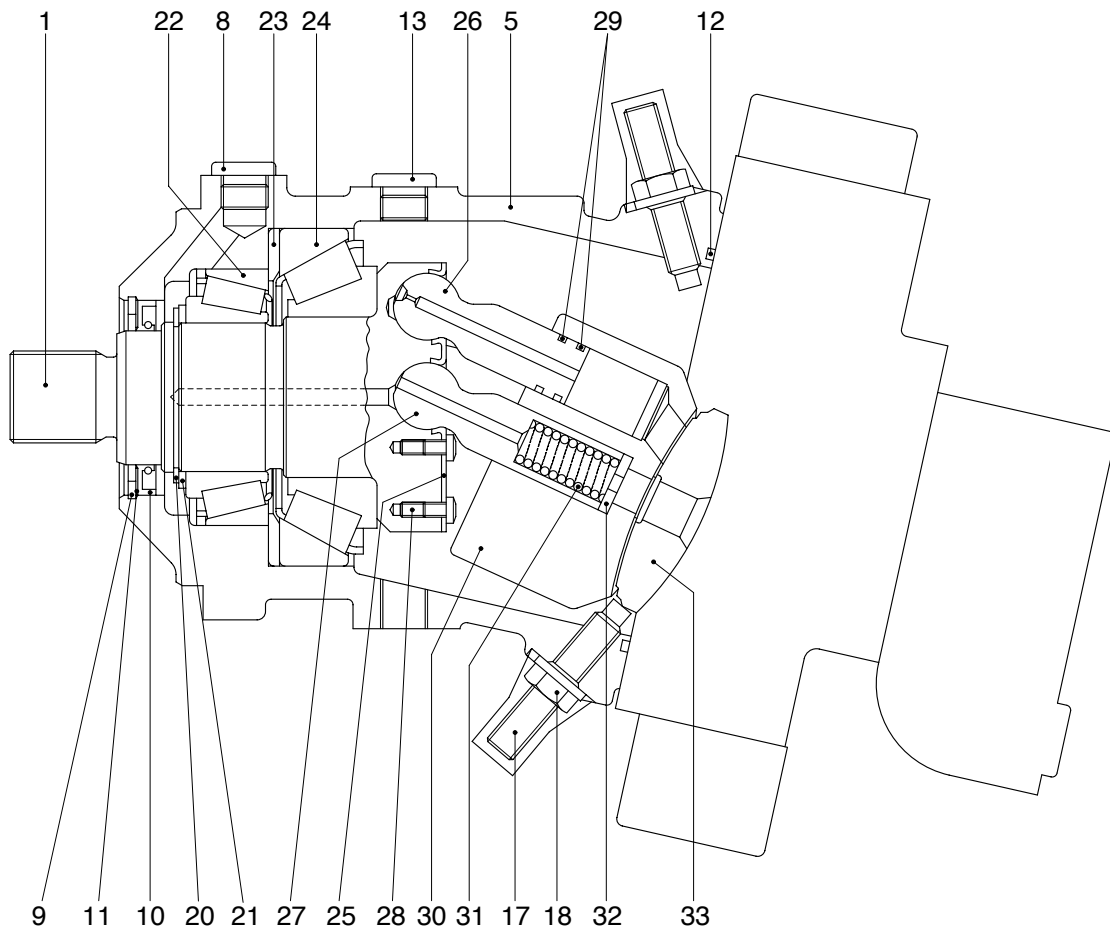

200W34TM02

1	Drive shaft	17	Threaded pin	26	Piston
5	Housing	18	Seal lock nut	27	Center pin
8	Locking screw	20	Retaining ring	28	Pan head screw
9	Retaining ring	21	Back up plate	29	Steel sealing ring
10	Shaft seal ring	22	Taper roller bearing	30	Cylinder block
11	Back up plate	23	Shim	31	Pressure spring
12	O-ring	24	Taper roller bearing	32	Adjustment shim
13	Locking screw	25	Retaining plate	33	Control lens

## 2) REGULATOR

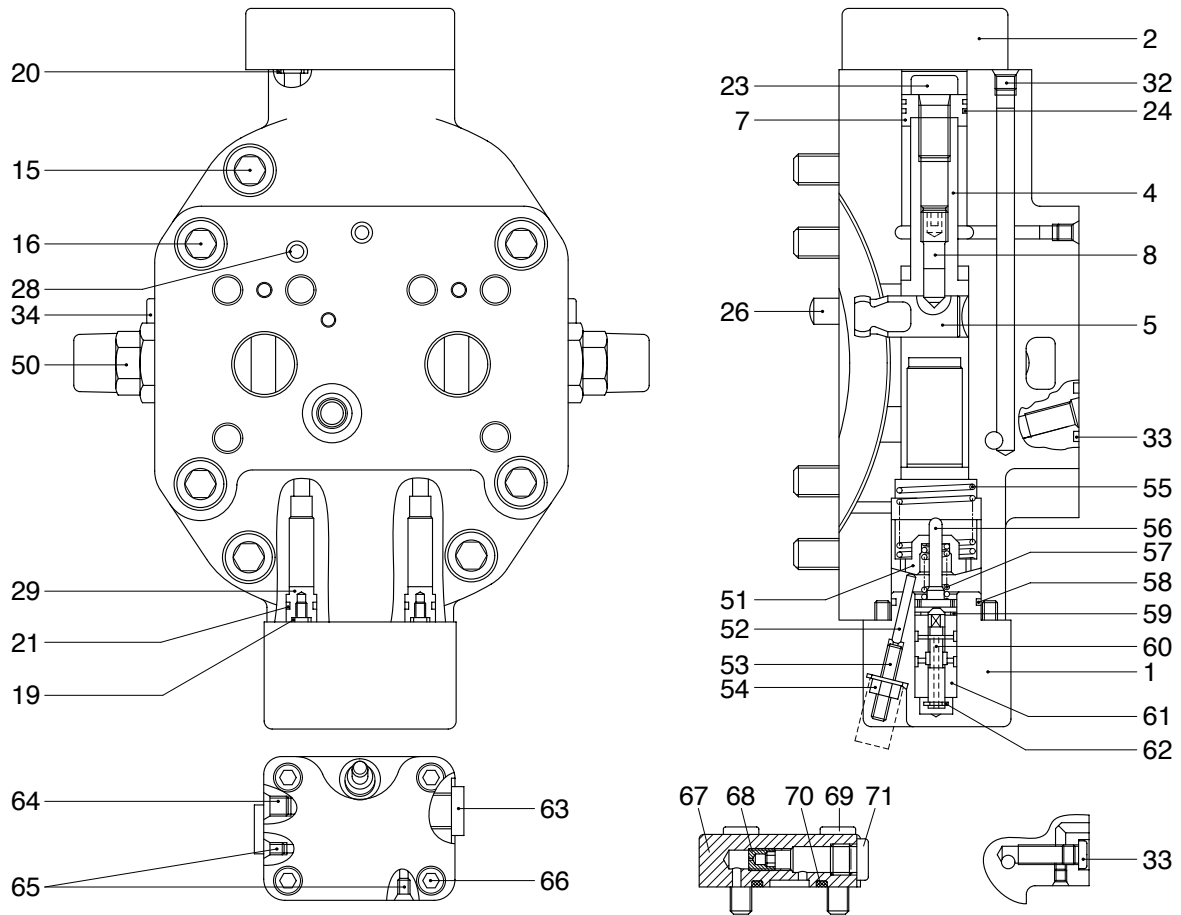

200W34TM03

1	Control housing	28	Double break off pin	59	Retaining ring
2	Cover	29	Plug	60	Control piston
4	Positioning piston	32	Double break off pin	61	Control bushing
5	Positioning trunnion	33	O-ring	62	Retaining disc
7	Piston	34	Locking screw	63	Locking screw
8	Threaded pin	50	Relief valve	64	Double break off pin
15	Socket head screw	51	Adjusting bushing	65	Double break off pin
16	Socket head screw	52	Cylinder pin	66	Socket head screw
19	O-ring	53	Threaded pin	67	Cover
20	O-ring	54	Seal lock nut	68	Throttle screw
21	O-ring	55	Pressure spring	69	Socket head screw
23	Socket head screw	56	Spring collar	70	O-ring
24	Square ring	57	Pressure spring	71	Locking screw
26	Cylinder pin	58	O-ring		

## 2. FUNCTION

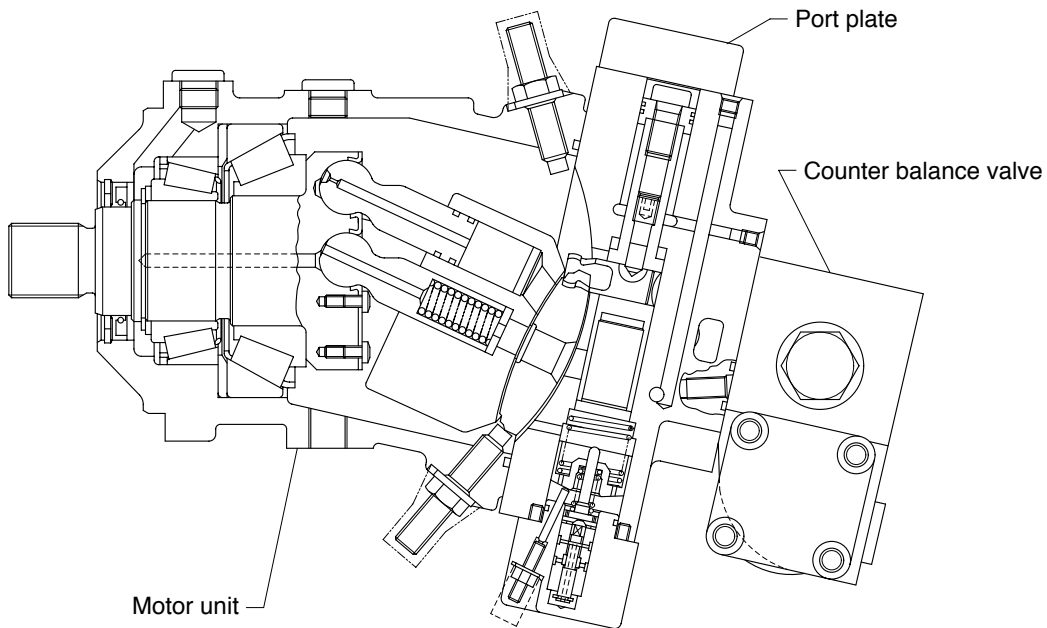

200W34TM05

### 1) VARIABLE DISPLACEMENT MOTOR(With integrated counterbalance valve)

The variable displacement motor has a rotary group in bent axis design.

The torque is generated directly at the drive shaft.

The cylinder barrel is driven by a tapered piston arrangement.

The change of displacement is generated by the control lens via positioning piston. The control lens slides on a circular shaped surface.

#### **In case of constant pump flow volume and high pressure**

- The output speed is increased at smaller swivel angle, the torque is reduced
- The torque rises at swivel angle increase, the output speed is decreased

The max swivel angle is 25°, the min swivel angle is 0°.

The variable displacement motor with integrated counterbalance valve is designed to be operated in open loop.

Min and max displacement are limited by a stop screw. Stepless adjustment to various higher values is possible.

**Reduction to smaller displacement may result in overspeeding the motor.**

### 2) PORT PLATE

With high pressure dependent control HA1, mounted counterbalance valve, integrated secondary pressure relief valves, plugged gauge and boosting ports, service ports to the rear.

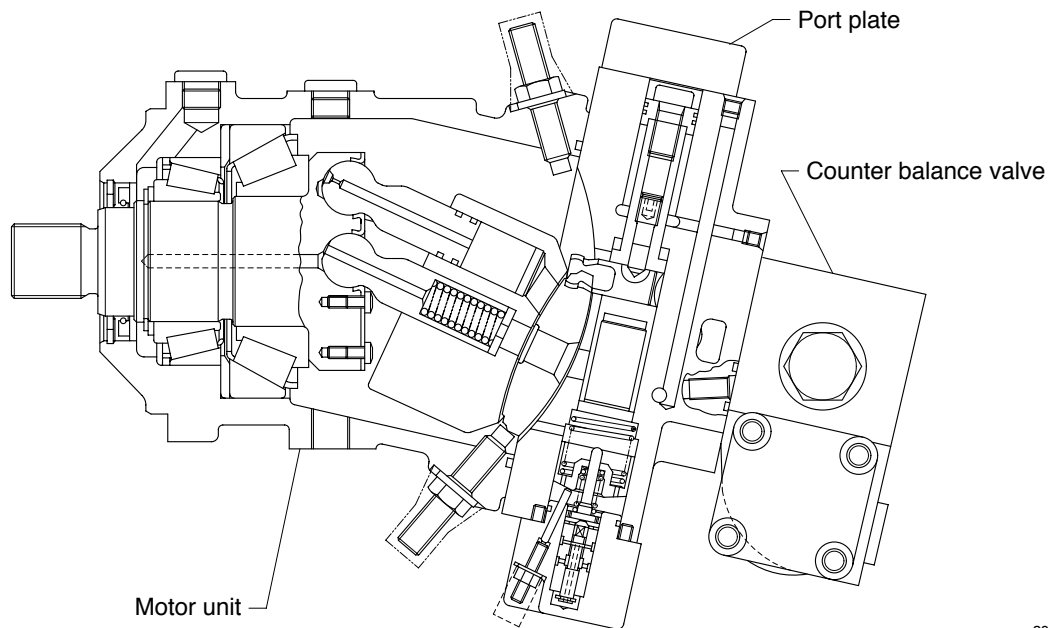

200W34TM05

### 3) HIGH PRESSURE DEPENDENT CONTROL

The displacement is dependent on operating pressure - automatically adjusted. Upon reaching the operating pressure set at the control valve - internally measured at A or B - the motor swivels from  $V_{gmin}$  to  $V_{gmax}$  until output torque = load torque. For values lower than the adjusted one the motor keeps min swivel angle. The necessary positioning energy is taken from the respective high pressure side via shuttle valve.

Swivelling results in a change of the displacement.

Swivel time is controlled by an orifice installed in the cover of the large positioning piston side.

### 4) COUNTERBALANCE VALVE

Mounted at the rear of the port plate.

In case of downhill traveling or deceleration of the machine a counterbalance valve avoids overspeeding and cavitation of hydraulic motor.

### 5) FUNCTION AS TO CIRCUIT DIAGRAM

Check valves in the inlet line A and B for by passing of the counterbalance valve.

At traveling forward the return oil flow is controlled by a counterbalance spool. At drop in inlet pressure the counterbalance spool throttles the return oil flow. The motor is locked. The oil behind the spool is led to the low pressure side via an additional check valve. Same function for traveling forward and backward.

Braking means for the motor that

- At reduced or zero inlet flow the counterbalance spool reaches a modulating position or a neutral position caused by spring force
- The high pressure oil (At outlet side of the motor) is returned to the low pressure side (At inlet side) of the motor via crossover relief valves.

As the control pressure for regulation of the HA control via the integrated shuttle valve is no longer available, the motor with HA control and counterbalance valve will swivel to its minimum displacement during deceleration.

In addition, an external boost flow/pressure can be applied at port S for preventing cavitation.

**Counterbalance valves do not replace the service and parking brake.**

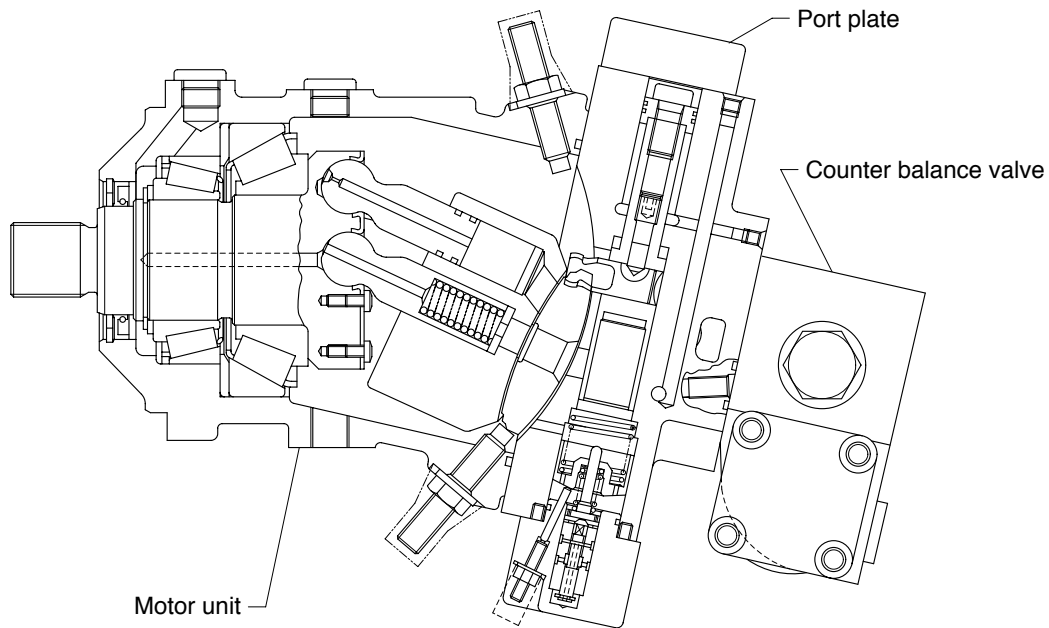

200W34TM05

#### 6) INSTALLATION

The housing must be filled entirely with oil and shall also not run empty at rotary group standstill.

#### 7) FILTRATION

According to purity class 9 as to NAS 1638, 6 as to SAE, ASTM, AIA and 18/15 as to ISO/DIS 4406.

#### 8) PRESSURE

Ports A or B : Normal 400bar, peak pressure 450bar

Port A + B : Pressure summation below 700bar

Max permissible intermittent case pressure : 6bar

#### 9) DIRECTION OF ROTATION/ DIRECTION OF FLOW

With view on the drive shaft - clockwise/ A to B; Counter-clockwise/ B to A

#### 10) LEAKAGE OIL TEMPERATURE

In the bearing area max permitted -25,C to +80,C; Short time operation -40,C to +115,C

#### 11) COMMISSIONING

Fill the housing entirely with oil through highest located T port. Also connect the leakage oil pipe at this port. After commissioning check sealing and make visual control of the complete installation.