

# GROUP 2 SPECIFICATIONS

## 1. MAJOR COMPONENT

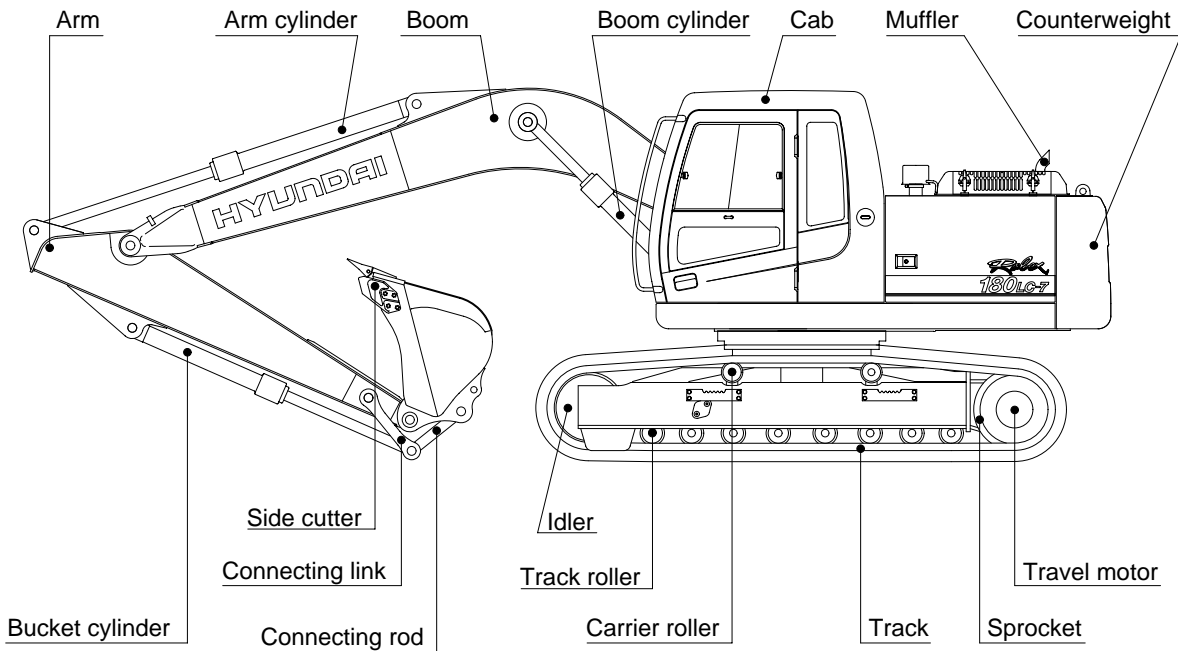
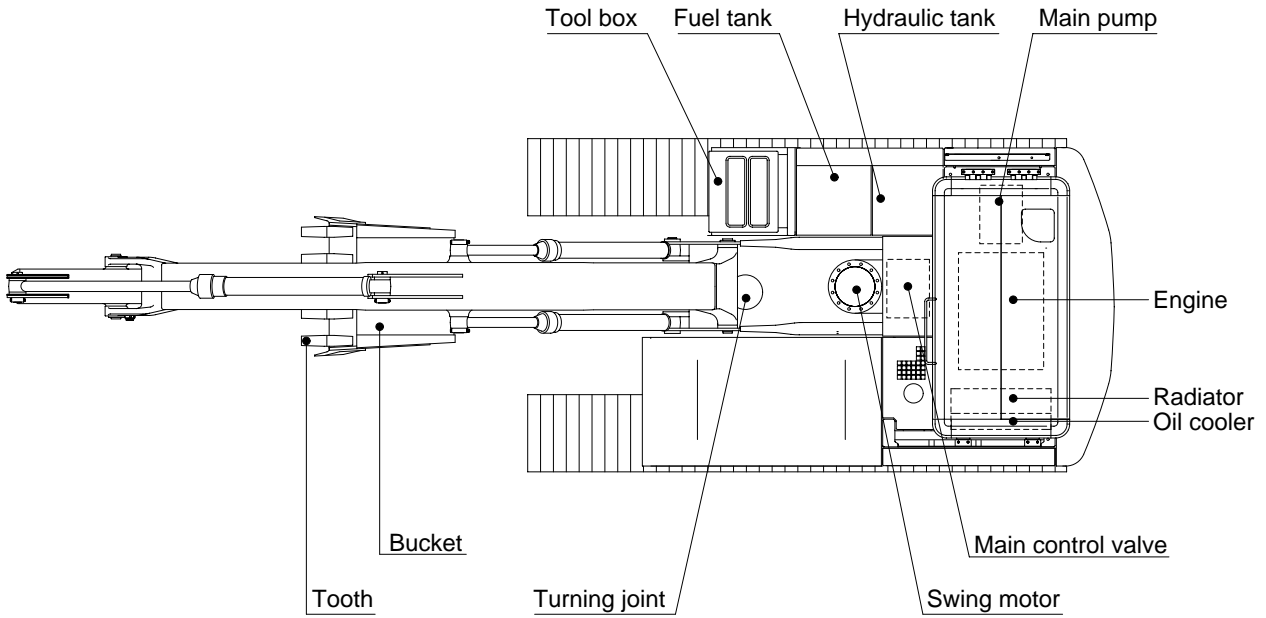

18072SP01

## 2. SPECIFICATIONS

### 1) 5.1m(16' 9") ONE PIECE BOOM, 2.6m(8' 6") ARM

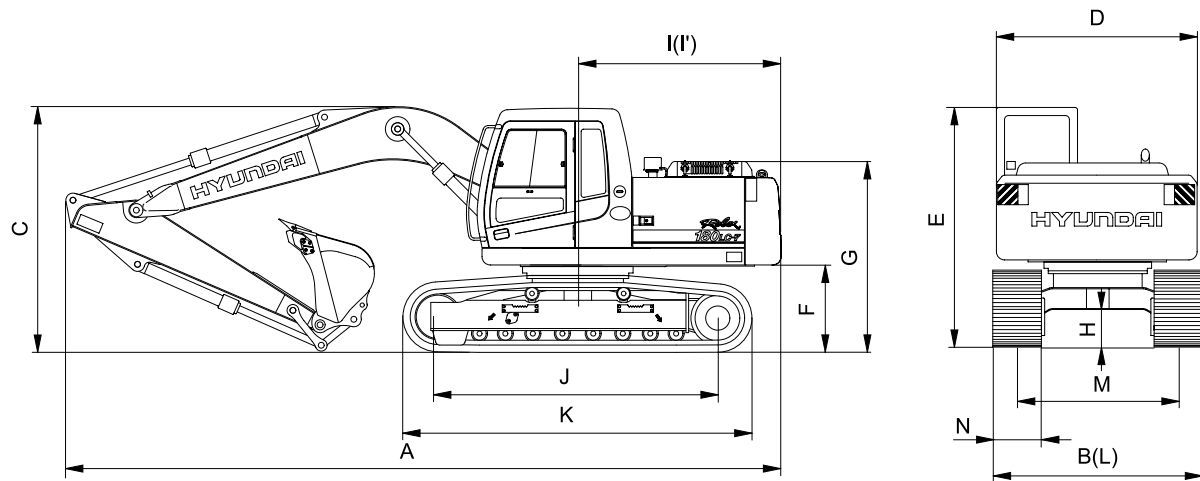

18072SP02

Description	Unit	Specification
Operating weight	kg(lb)	18200(40120)
Bucket capacity(SAE heaped), standard	m <sup>3</sup> (yd <sup>3</sup> )	0.76(0.99)
Overall length	A	8600(28' 3")
Overall width, with 600mm shoe	B	2590( 8' 6")
Overall height	C	2910( 9' 7")
Superstructure width	D	2475( 8' 1")
Overall height of cab	E	2915( 9' 7")
Ground clearance of counterweight	F	1050( 3' 5")
Engine cover height	G	2295( 7' 6")
Minimum ground clearance	H	460( 1' 6")
Rear-end distance	I	2530( 8' 4")
Rear-end swing radius	I'	2480( 8' 2")
Distance between tumbler	J	3360(11' 0")
Undercarriage length	K	4190(13' 9")
Undercarriage width	L	2590( 8' 6")
Track gauge	M	2250( 7' 5")
Track shoe width, standard	N	600(24")
Travel speed(Low/high)	km/hr(mph)	3.3/5.2(2.0/3.2)
Swing speed	rpm	12.0
Gradeability	Degree(%)	30(58)
Ground pressure(600mm shoe)	kgf/cm <sup>2</sup> (psi)	0.42(5.97)

## 2) 5.1m(16' 9") HYDRAULIC ADJUSTABLE BOOM, 2.6m(8' 6") ARM

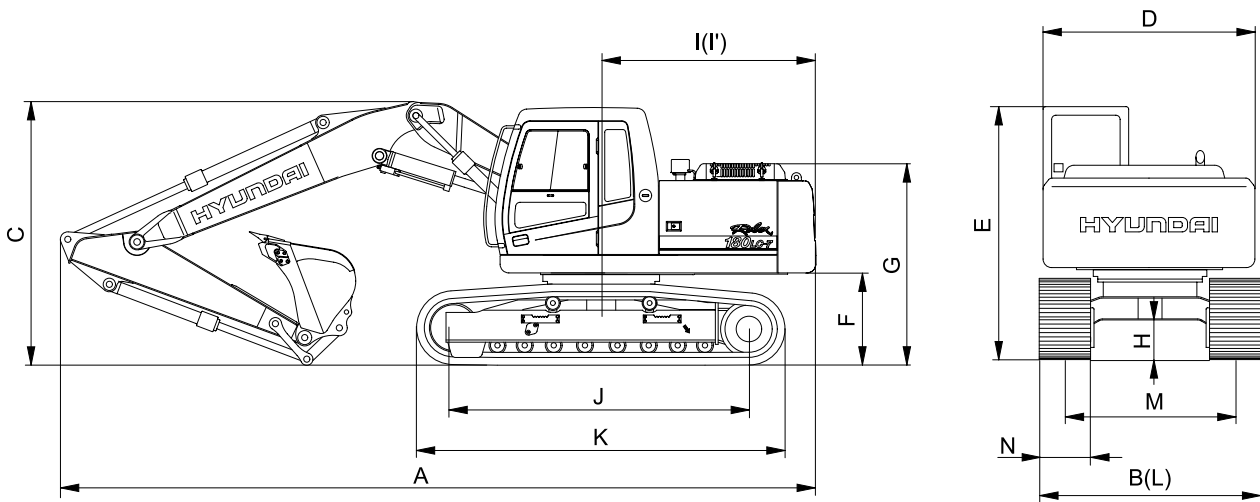

18072SP05

Description		Unit	Specification
Operating weight		kg(lb)	18200(40120)
Bucket capacity(SAE heaped), standard		m <sup>3</sup> (yd <sup>3</sup> )	0.76(0.99)
Overall length	A	mm(ft-in)	8570(28' 1")
Overall width, with 600mm shoe	B		2590( 8' 10")
Overall height	C		2820( 9' 3")
Superstructure width	D		2530( 8' 4")
Overall height of cab	E		2915( 9' 7")
Ground clearance of counterweight	F		1050( 3' 5")
Engine cover height	G		2295( 7' 6")
Minimum ground clearance	H		460( 1' 6")
Rear-end distance	I		2530( 8' 4")
Rear-end swing radius	I'		2480( 8' 2")
Distance between tumblers	J		3360(11' 0")
Undercarriage length	K		4190(13' 9")
Undercarriage width	L		2690( 8' 10")
Track gauge	M		2250( 6' 6")
Track shoe width, standard	N		600(24")
Travel speed(Low/high)		km/hr(mph)	3.3/5.2(2.0/3.2)
Swing speed		rpm	12.0
Gradeability		Degree(%)	30(58)
Ground pressure(600mm shoe)		kgf/cm <sup>2</sup> (psi)	0.42(5.97)

### 3. WORKING RANGE

#### 1) 5.1m(16' 9") MONO BOOM

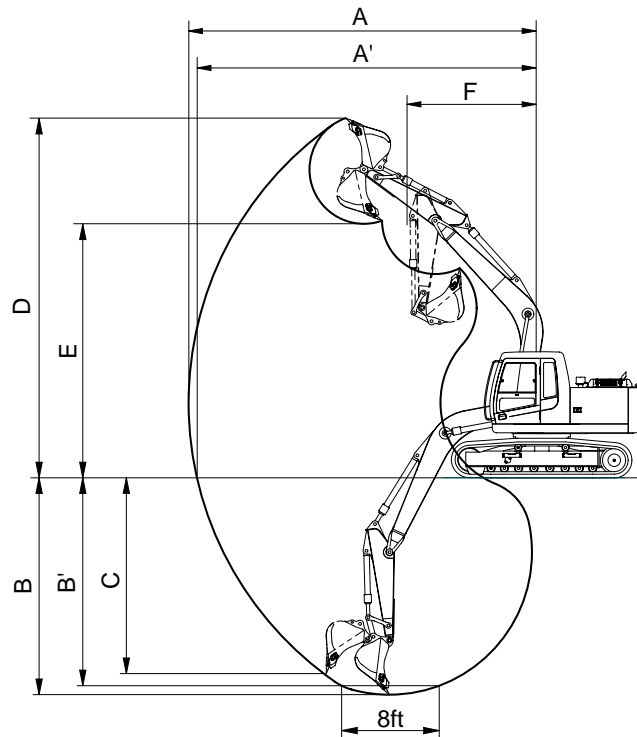

18072SP03

Description		2.2m(7' 3") Arm	2.6m(8' 6") Arm	3.1m(10' 2") Arm
Max digging reach	A	8690mm (28' 6")	9030mm (29' 8")	9450mm (31' 0")
Max digging reach on ground	A'	8530mm (27'12")	8870mm (29' 1")	9300mm (30' 6")
Max digging depth	B	5660mm (18' 7")	6060mm (19'11")	6560mm (21' 6")
Max digging depth (8ft level)	B'	5440mm (17'10")	5860mm (19' 3")	6370mm (20'11")
Max vertical wall digging depth	C	5140mm (16'10")	5440mm (17'10")	5730mm (18'10")
Max digging height	D	8740mm (28' 8")	8870mm (29' 1")	8970mm (29' 5")
Max dumping height	E	6100mm (20' 0")	6240mm (20' 6")	6380mm (20'11")
Min swing radius	F	3180mm (10' 5")	3170mm (10' 5")	3180mm (10' 5")
Bucket digging force	SAE	108.6 [118.4]kN	108.6 [118.4] kN	108.6 [118.4] kN
		11070 [12080]kgf	11070 [12080] kgf	11070 [12080] kgf
		24410 [26630]lbf	24410 [26630] lbf	24410 [26630] lbf
	ISO	124.5 [135.9]kN	124.5 [135.9] kN	124.5 [135.9] kN
		12700 [13850]kgf	12700 [13850] kgf	12700 [13850] kgf
		28000 [30550]lbf	28000 [30550] lbf	28000 [30550] lbf
Arm digging force	SAE	85.2 [93.0]kN	75.0 [81.8] kN	67.4 [73.5] kN
		8690 [9480]kgf	7650 [8350] kgf	6870 [7490] kgf
		19160 [20900]lbf	16870 [18400] lbf	15150 [16530] lbf
	ISO	89.0 [97.1]kN	77.6 [84.6] kN	69.4 [75.7] kN
		9080 [9910]kgf	7910 [8630] kgf	7080 [7720] kgf
		20020 [21840]lbf	17440 [19030] lbf	15610 [17030] lbf

[ ] : Power boost

## 2) 5.1m(16' 9") HYDRAULIC ADJUSTABLE BOOM

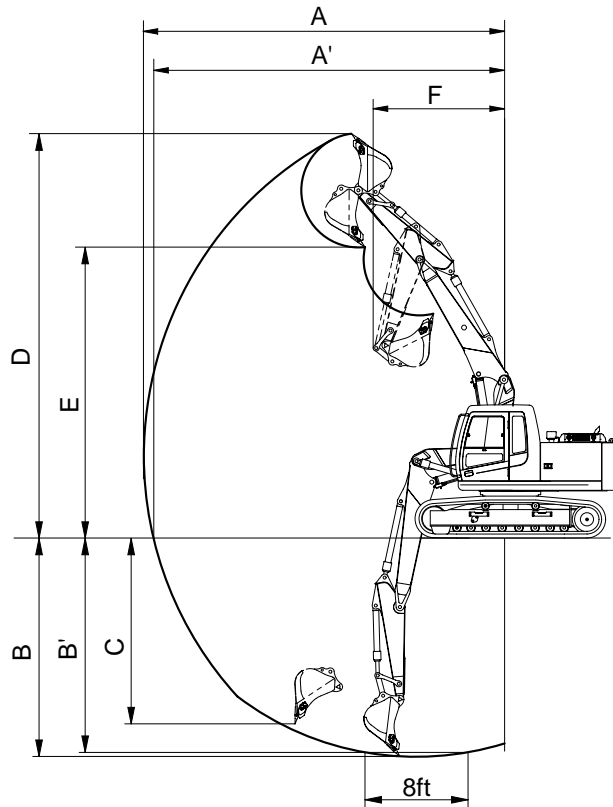

18072SP04

Description		2.2m(7' 3") Arm	2.6m(8' 6") Arm
Max digging reach	A	8750mm (28' 8")	9110mm (29'11")
Max digging reach on ground	A'	8600mm (28' 3")	8960mm (29' 5")
Max digging depth	B	5460mm (17'11")	5830mm (19' 2")
Max digging depth (8ft level)	B'	5350mm (17' 7")	5750mm (18'10")
Max vertical wall digging depth	C	4670mm (15' 4")	5030mm (16' 6")
Max digging height	D	9390mm (30'10")	9600mm (31' 6")
Max dumping height	E	6680mm (21'11")	6900mm (22' 8")
Min swing radius	F	3130mm (10' 3")	2970mm ( 9' 9")
Bucket digging force	SAE	108.6 [118.4]kN	108.6 [118.4] kN
		11070 [12080]kgf	11070 [12080] kgf
		24410 [26630]lbf	24410 [26630] lbf
	ISO	124.5 [135.9]kN	124.5 [135.9] kN
		12700 [13850]kgf	12700 [13850] kgf
		28000 [30550]lbf	28000 [30550] lbf
Arm digging force	SAE	85.2 [93.0]kN	75.0 [81.8] kN
		8690 [9480]kgf	7650 [8350] kgf
		19160 [20900]lbf	16870 [18400] lbf
	ISO	89.0 [97.1]kN	77.6 [84.6] kN
		9080 [9910]kgf	7910 [8630] kgf
		20020 [21840]lbf	17440 [19030] lbf

[ ] : Power boost

#### 4. WEIGHT

Item	kg	lb
Upperstructure assembly	7480	16490
Main frame weld assembly	1400	3090
Engine assembly	350	770
Main pump assembly	90	200
Main control valve assembly	80	180
Swing motor assembly	250	550
Hydraulic oil tank assembly	180	400
Fuel tank assembly	140	310
Counterweight	2950	6500
Cab assembly	310	680
Lower chassis assembly	7670	16910
Track frame weld assembly	2130	4700
Swing bearing	260	570
Travel motor assembly	240	530
Turning joint	50	120
Track recoil spring	140	310
Idler	160	350
Carrier roller	20	45
Track roller	50	120
Track-chain assembly(600mm standard triple grouser shoe)	1180	2600
Front attachment assembly(5.1m boom, 2.6m arm, 0.76m <sup>3</sup> SAE heaped bucket)	3050	6720
5.1m boom assembly	1250	2760
2.6m arm assembly	800	1760
0.76m <sup>3</sup> SAE heaped bucket	570	1260
Boom cylinder assembly	160	350
Arm cylinder assembly	180	400
Bucket cylinder assembly	140	310
Bucket control link assembly	120	265











## 5. LIFTING CAPACITIES

### 1) R180LC-7

(1) 5.1m(16' 9") boom, 2.2m(7' 3") arm equipped with 0.76m<sup>3</sup>(SAE heaped) bucket and 600mm(24") triple grouser shoe.













•  : Rating over-front

•  : Rating over-side or 360 degree













Load point height		Load radius								At max. reach		
		1.5m(5ft)		3.0m(10ft)		4.5m(15ft)		6.0m(20ft)		Capacity		Reach m(ft)
												
7.5m (25ft)	kg lb									*3380 *7450	*3380 *7450	5.81 (19.1)
6.0m (20ft)	kg lb									*3320 *7320	2730 6020	7.16 (23.5)
4.5m (15ft)	kg lb					*4240 *9350	*4240 *9350	*3800 *8380	3590 7910	*3340 *7360	2230 4920	7.92 (26.0)
3.0m (10ft)	kg lb			*8440 *18610	*8440 *18610	*5370 *11840	*5370 *11840	*4250 *9370	3450 7610	3230 7120	2010 4430	8.30 (27.2)
1.5m (5ft)	kg lb					*6520 *14370	5100 11240	*4780 *10540	3290 7250	3160 6970	1950 4300	8.34 (27.4)
Ground Line	kg lb			*6730 *14840	*6730 *14840	*7130 *15720	4870 10740	*5110 *11270	3170 6990	3310 7300	2030 4480	8.06 (26.4)
-1.5m (-5ft)	kg lb	*6630 *14620	*6630 *14620	*10510 *23170	9380 20680	*7050 *15540	4810 10600	*5050 *11130	3120 6880	*3580 *7890	2330 5140	7.42 (24.3)
-3.0m (-10ft)	kg lb	*10580 *23320	*10580 *23320	*8940 *19710	*8940 *19710	*6190 *13650	4870 10740			*3360 *7410	3090 6810	6.28 (20.6)
-4.5m (-15ft)	kg lb			*5810 *12810	*5810 *12810							

- Note
1. Lifting capacity are based on SAE J1097 and ISO 10567.
  2. Lifting capacity of the ROBEX series does not exceed 75% of tipping load with the machine on firm, level ground or 87% of full hydraulic capacity.
  3. The load point is a hook located on the back of the bucket.
  4. \*indicates load limited by hydraulic capacity.













(2) 5.1m(16' 9") boom, 2.6m(8' 6") arm equipped with 0.76m<sup>3</sup>(SAE heaped) bucket and 600mm(24") triple grouser shoe.

Load point height		Load radius										At max. reach		
		1.5m(5ft)		3.0m(10ft)		4.5m(15ft)		6.0m(20ft)		7.5m(25ft)		Capacity		Reach
														m(ft)
7.5m (25ft)	kg lb											*3060 *6750	*3060 *6750	6.33 (20.8)
6.0m (20ft)	kg lb						*2730 *6020	*2730 *6020				*3040 *6700	2480 5470	7.56 (24.8)
4.5m (15ft)	kg lb						*3480 *7670	*3480 *7670				*3090 *6810	2050 4520	8.28 (27.2)
3.0m (10ft)	kg lb			*7340 *16180	*7340 *16180	*4920 *10850	*4920 *10850	*3970 *8750	3460 7630	*2540 *5600	2340 5160	3010 6640	1850 4080	8.64 (28.3)
1.5m (5ft)	kg lb			*7700 *16980	*7700 *16980	*6170 *13600	5120 11290	*4550 *10030	3280 7230	*3320 *7320	2270 5000	2940 6480	1790 3950	8.68 (28.5)
Ground Line	kg lb			*7450 *16420	*7450 *16420	*6950 *15320	4850 10690	*4980 *10980	3130 6900	*3150 *6940	2200 4850	3050 6720	1860 4100	8.42 (27.6)
-1.5m (-5ft)	kg lb	*6320 *13930	*6320 *13930	*10020 *22090	9260 20410	*7070 *15590	4740 10450	*5050 *11130	3060 6750			*3430 *7560	2100 4630	7.81 (25.6)
-3.0m (-10ft)	kg lb	*9350 *20610	*9350 *20610	*9550 *21050	9390 20700	*6450 *14220	4770 10520	*4500 *9920	3090 6810			*3350 *7390	2700 5950	6.75 (22.1)
-4.5m (-15ft)	kg lb			*6930 *15280	*6930 *15280	*4590 *10120	*4590 *10120							













(3) 5.1m(16' 9") boom, 3.1m(11' 1") arm equipped with 0.76m<sup>3</sup>(SAE heaped) bucket and 600mm(24") triple grouser shoe.

Load point height		Load radius										At max. reach			
		1.5m(5ft)		3.0m(10ft)		4.5m(15ft)		6.0m(20ft)		7.5m(25ft)		Capacity		Reach	
														m(ft)	
7.5m (25ft)	kg lb											*2700 *5950	*2700 *5950	6.92 (22.7)	
6.0m (20ft)	kg lb							*2620 *5780	*2620 *5780				*2730 *6020	2200 4850	8.05 (26.4)
4.5m (15ft)	kg lb							*3090 *6810	*3090 *6810	*1910 *4210	*1910 *4210	*2800 *6170	1840 4060	8.73 (28.6)	
3.0m (10ft)	kg lb					*4350 *9590	*4350 *9590	*3620 *7980	3460 7630	*2820 *6220	2330 5140	2690 5930	1660 3660	9.06 (29.7)	
1.5m (5ft)	kg lb			*9480 *20900	*9480 *20900	*5700 *12570	5150 11350	*4260 *9390	3260 7190	*3540 *7800	2240 4940	2620 5780	1610 3550	9.10 (29.9)	
Ground Line	kg lb			*8230 *18140	*8230 *18140	*6680 *14730	4820 10630	*4790 *10560	3090 6810	3490 7690	2150 4740	2710 5970	1660 3660	8.85 (29.0)	
-1.5m (-5ft)	kg lb	*5980 *13180	*5980 *13180	*9760 *21520	9120 20110	*7020 *15480	4670 10300	4890 10780	2990 6590	*2950 *6500	2110 4650	3000 6610	1850 4080	8.28 (27.2)	
-3.0m (-10ft)	kg lb	*8450 *18630	*8450 *18630	*10130 *22330	9180 20240	*6670 *14700	4650 10250	*4720 *10410	2980 6570			*3270 *7210	2300 5070	7.30 (24.0)	
-4.5m (-15ft)	kg lb	*11670 *25730	*11670 *25730	*8010 *17660	*8010 *17660	*5360 *11820	4770 10520								

(4) 5.1m(16' 9") hydraulic adjustable boom, 2.2m(7' 3") arm equipped with 0.76m<sup>3</sup>(SAE heaped) bucket and 600mm(24") triple grouser shoe.

Load point height		Load radius										At max. reach		
		1.5m(5ft)		3.0m(10ft)		4.5m(15ft)		6.0m(20ft)		7.5m(25ft)		Capacity		Reach
														m(ft)
6.0m (20ft)	kg lb											*3370 *7430	2670 5890	7.24 (23.8)
4.5m (15ft)	kg lb						*3840 *8470	3600 7940				*3340 *7360	2180 4810	7.99 (26.2)
3.0m (10ft)	kg lb					*5410 *11930	*5410 *11930	*4260 *9390	3450 7610			3200 7050	1960 4320	8.36 (27.4)
1.5m (5ft)	kg lb					*6470 *14260	5080 11200	*4740 *10450	3270 7210	*3220 *7100	2270 5000	3140 6920	1900 4190	8.41 (27.6)
Ground Line	kg lb			*5880 *12960	*5880 *12960	*7010 *15450	4840 10670	*5030 *11090	3140 6920			3290 7250	2000 4410	8.13 (26.7)
-1.5m (-5ft)	kg lb	*5870 *12940	*5870 *12940	*9760 *21520	9340 20590	*6870 *15150	4780 10540	*4920 *10850	3100 6830			*3320 *7320	2290 5050	7.50 (24.6)
-3.0m (-10ft)	kg lb			*8470 *18670	*8470 *18670	*5920 *13050	4860 10710					*2910 *6420	*2910 *6420	6.37 (20.9)

(5) 5.1m(16' 9") hydraulic adjustable boom, 2.6m(8' 6") arm equipped with 0.76m<sup>3</sup>(SAE heaped) bucket and 600mm(24") triple grouser shoe.

Load point height		Load radius										At max. reach		
		1.5m(5ft)		3.0m(10ft)		4.5m(15ft)		6.0m(20ft)		7.5m(25ft)		Capacity		Reach
														m(ft)
6.0m (20ft)	kg lb											*3100 *6830	2410 5310	7.66 (25.1)
4.5m (15ft)	kg lb											*3090 *6810	2000 4410	8.37 (27.5)
3.0m (10ft)	kg lb							*3990 *8800	3460 7630	*2920 *6440	2330 5140	2970 6550	1800 3970	8.72 (28.6)
1.5m (5ft)	kg lb			*6670 *14700	*6670 *14700	*6150 *13560	5110 11270	*4530 *9990	3260 7190	*3680 *8110	2250 4960	2900 6390	1740 3840	8.77 (28.8)
Ground Line	kg lb			*6670 *14700	*6670 *14700	*6860 *15120	4820 10630	*4910 *10820	3110 6860	3630 8000	2190 4830	3020 6660	1820 4010	8.50 (27.9)
-1.5m (-5ft)	kg lb	*5710 *12590	*5710 *12590	*9370 *20660	9220 20330	*6910 *15230	4710 10380	*4940 *10890	3040 6700			*3180 *7010	2060 4540	7.90 (25.9)
-3.0m (-10ft)	kg lb	*8910 *19640	*8910 *19640	*9130 *20130	*9130 *20130	*6210 *13690	4750 10470	*4310 *9500	3080 6790			*2940 *6480	2640 5820	6.86 (22.5)
-4.5m (-15ft)	kg lb			*6310 *13910	*6310 *13910	*4190 *9240	*4190 *9240							

## 6. BUCKET SELECTION GUIDE

### 1) GENERAL BUCKET

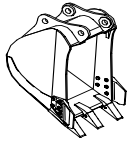
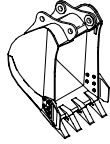
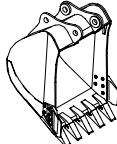
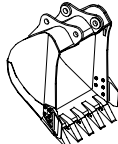
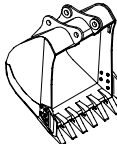
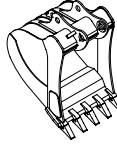
					
0.39m <sup>3</sup> SAE heaped bucket	0.50m <sup>3</sup> SAE heaped bucket	0.64m <sup>3</sup> SAE heaped bucket	0.76m <sup>3</sup> SAE heaped bucket	1.05m <sup>3</sup> SAE heaped bucket	0.69m <sup>3</sup> SAE heaped bucket

Capacity		Width		Weight	Recommendation				
					5.1m (16' 9") Mono boom			5.1m (16' 9") Hydraulic adjustable boom	
SAE heaped	CECE heaped	Without side cutter	With side cutter		2.0m arm (7' 3")	2.6m arm (8' 6")	3.1m arm (10' 2")	2.2m arm (7' 3")	2.6m arm (8' 6")
0.39m <sup>3</sup> (0.51yd <sup>3</sup> )	0.34m <sup>3</sup> (0.44yd <sup>3</sup> )	620mm (24.4")	740mm (29.1")	410kg (900lb)					
0.50m <sup>3</sup> (0.65yd <sup>3</sup> )	0.44m <sup>3</sup> (0.58yd <sup>3</sup> )	760mm (29.9")	880mm (34.6")	470kg (1040lb)					
0.64m <sup>3</sup> (0.84yd <sup>3</sup> )	0.55m <sup>3</sup> (0.72yd <sup>3</sup> )	920mm (36.2")	1040mm (40.9")	510kg (1120lb)					
0.76m <sup>3</sup> (0.99yd <sup>3</sup> )	0.65m <sup>3</sup> (0.85yd <sup>3</sup> )	1060mm (41.7")	1180mm (46.5")	570kg (1260lb)					
0.89m <sup>3</sup> (1.16yd <sup>3</sup> )	0.77m <sup>3</sup> (1.01yd <sup>3</sup> )	1220mm (48.0")	1340mm (52.8")	610kg (1340lb)					
1.05m <sup>3</sup> (1.37yd <sup>3</sup> )	0.90m <sup>3</sup> (1.18yd <sup>3</sup> )	1400mm (55.1")	1520mm (59.8")	680kg (1500lb)					
0.69m <sup>3</sup> (0.9yd <sup>3</sup> )	0.62m <sup>3</sup> (0.81yd <sup>3</sup> )	990mm (39.0")	-						

: Standard bucket

: Heavy duty bucket

 Applicable for materials with density of 2000kg/m<sup>3</sup> (3370lb/yd<sup>3</sup>) or less

 Applicable for materials with density of 1600kg/m<sup>3</sup> (2700lb/yd<sup>3</sup>) or less

 Applicable for materials with density of 1100kg/m<sup>3</sup> (1850lb/yd<sup>3</sup>) or less

## 7. UNDERCARRIAGE

### 1) TRACKSTRACKS

X-leg type center frame is integrally welded with reinforced box-section track frames. The design includes dry tracks, lubricated rollers, idlers, sprockets, hydraulic track adjusters with shock absorbing springs and assembled track-type tractor shoes with triple grousers.

### 2) TYPES OF SHOES

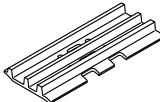
Model	Shapes		Triple grouser			
						
R180LC-7	Shoe width	mm(in)	500(20)	600(24)	700(28)	800(32)
	Operating weight	kg(lb)	17950(39570)	18200(40120)	18450(40670)	18710(41250)
	Ground pressure	kgf/cm <sup>2</sup> (psi)	0.50(7.11)	0.42(5.97)	0.37(5.26)	0.32(4.55)
	Overall width	mm(ft-in)	2750(9' 0")	2850(9' 4")	2950(9' 8")	3050(10' 0")

### 3) NUMBER OF ROLLERS AND SHOES ON EACH SIDE

Item	Quantity
Carrier rollers	2EA
Track rollers	8EA
Track shoes	51EA

### 4) SELECTION OF TRACK SHOE

Suitable track shoes should be selected according to operating conditions.

#### Method of selecting shoes

Confirm the category from the list of applications in **table 2**, then use **table 1** to select the shoe. Wide shoes(Categories B and C) have limitations on applications. Before using wide shoes, check the precautions, then investigate and study the operating conditions to confirm if these shoes are suitable.

Select the narrowest shoe possible to meet the required flotation and ground pressure. Application of wider shoes than recommendations will cause unexpected problem such as bending of shoes, crack of link, breakage of pin, loosening of shoe bolts and the other various problems.

**Table 1**

Track shoe	Specification	Category
500mm triple grouser	Option	A
600mm triple grouser	Standard	A
700mm triple grouser	Option	B
800mm triple grouser	Option	C

**Table 2**

Category	Applications	Precautions
A	Rocky ground, river beds, normal soil	<ul style="list-style-type: none"><li>• Travel at low speed on rough ground with large obstacles such as boulders or fallen trees</li></ul>
B	Normal soil, soft ground	<ul style="list-style-type: none"><li>• These shoes cannot be used on rough ground with large obstacles such as boulders or fallen trees</li><li>• Travel at high speed only on flat ground</li><li>• Travel slowly at low speed if it is impossible to avoid going over obstacles</li></ul>
C	Extremely soft ground (Swampy ground)	<ul style="list-style-type: none"><li>• Use the shoes only in the conditions that the machine sinks and it is impossible to use the shoes of category A or B</li><li>• These shoes cannot be used on rough ground with large obstacles such as boulders or fallen trees</li><li>• Travel at high speed only on flat ground</li><li>• Travel slowly at low speed if it is impossible to avoid going over obstacles</li></ul>

## 8. SPECIFICATIONS FOR MAJOR COMPONENTS

### 1) ENGINE

Item	Specification
Model	Mitsubishi S6S-DT
Type	4-cycle turbocharged diesel engine, low emission
Cooling method	Water cooling
Number of cylinders and arrangement	6 cylinders, in-line
Firing order	1-5-3-6-2-4
Combustion chamber type	Direct injection type
Cylinder bore x stroke	94 x 120mm(3.70" x 4.72")
Piston displacement	4996cc(305cu in)
Compression ratio	19.5 : 1
Rated gross horse power(SAE J1349)	126Hp at 2100rpm(94kW at 2100rpm)
Maximum torque at 1500rpm	42.5kgf · m(307lbf · ft)
Engine oil quantity	16.5 (4.4U.S. gal)
Dry weight	355kg(783lb)
High idling speed	2200+ 50rpm
Low idling speed	950 ± 100rpm
Rated fuel consumption	169.3g/Hp · hr at 2100rpm
Starting motor	Mitsubishi 24V-5.0kW
Alternator	Mitsubishi 24V-5.0A
Battery	2 x 12V x 100Ah

### 2) MAIN PUMP

Item	Specification
Type	Variable displacement tandem axis piston pumps
Capacity	2 x 80cc/rev
Maximum pressure	330kgf/cm <sup>2</sup> (4694psi) [360kgf/cm <sup>2</sup> (5120psi)]
Rated oil flow	2 x 168 /min (44.3U.S. gpm/ 40U.K. gpm)
Rated speed	2100rpm

[ ]: Poer boost

### 3) GEAR PUMP

Item	Specification
Type	Fixed displacement gear pump single stage
Capacity	15cc/rev
Maximum pressure	35kgf/cm <sup>2</sup> (500psi)
Rated oil flow	31.5 /min(8.3U.S. gpm/7.0U.K. gpm)

### 4) MAIN CONTROL VALVE

Item	Specification
Type	11 spools mono-block
Operating method	Hydraulic pilot system
Main relief valve pressure	330kgf/cm <sup>2</sup> (4695psi) [360kgf/cm <sup>2</sup> (5120psi)]
Overload relief valve pressure	380kgf/cm <sup>2</sup> (5550psi)

[ ]: Poer boost

### 5) SWING MOTOR

Item	Specification
Type	Two fixed displacement axial piston motor
Capacity	117.8cc/rev
Relief pressure	240kgf/cm <sup>2</sup> (3414psi)
Braking system	Automatic, spring applied hydraulic released
Braking torque	56kgf · m(405lb · ft)
Brake release pressure	20kgf/cm <sup>2</sup> (284psi)
Reduction gear type	2 - stage planetary
Swing speed	12.0rpm

### 6) TRAVEL MOTOR

Item	Specification
Type	Variable displacement axial piston motor
Relief pressure	330kgf/cm <sup>2</sup> (4695psi)
Reduction gear type	Planetary & differential type
Braking system	Automatic, spring applied hydraulic released
Brake release pressure	6kgf/cm <sup>2</sup> (85psi)
Braking torque	40.6kgf · m(294lb · ft)

## 7) REMOTE CONTROL VALVE

Item		Specification
Type		Pressure reducing type
Operating pressure	Minimum	6.5kgf/cm <sup>2</sup> (92psi)
	Maximum	26kgf/cm <sup>2</sup> (370psi)
Single operation stroke	Lever	61mm(2.4in)
	Pedal	123mm(4.84in)

## 8) CYLINDER

Item		Specification
Boom cylinder	Bore dia x Rod dia x Stroke	Ø115 x Ø80 x 1090mm
	Cushion	Extend only
Arm cylinder	Bore dia x Rod dia x Stroke	Ø120 x Ø85 x 1340mm
	Cushion	Extend and retract
Bucket cylinder	Bore dia x Rod dia x Stroke	Ø115 x Ø80 x 950mm
	Cushion	Extend only

**Discoloration of cylinder rod can occur when the friction reduction additive of lubrication oil spreads on the rod surface.**

**Discoloration does not cause any harmful effect on the cylinder performance.**

## 9) SHOE

Item		Width	Ground pressure	Link quantity	Overall width
R180LC-7	Option	500mm(20")	0.50kgf/cm <sup>2</sup> (7.11psi)	51	2750mm( 9' 0")
	Standard	600mm(24")	0.42kgf/cm <sup>2</sup> (5.97psi)	51	2850mm( 9' 4")
	Option	700mm(28")	0.36kgf/cm <sup>2</sup> (5.12psi)	51	2950mm( 9' 8")
	Option	800mm(32")	0.32kgf/cm <sup>2</sup> (4.55psi)	51	3050mm(10' 0")

## 10) BUCKET

Item		Capacity		Tooth quantity	Width		
		SAE heaped	CECE heaped		Without side cutter	With side cutter	
R180LC-7	STD	0.76m <sup>3</sup> (0.99yd <sup>3</sup> )	0.65m <sup>3</sup> (0.85yd <sup>3</sup> )	5	1060mm(41.7")	1180mm(46.5")	
	OPT		0.39m <sup>3</sup> (0.51yd <sup>3</sup> )	0.34m <sup>3</sup> (0.44yd <sup>3</sup> )	3	620mm(24.4")	740mm(29.1")
			0.50m <sup>3</sup> (0.65yd <sup>3</sup> )	0.44m <sup>3</sup> (0.58yd <sup>3</sup> )	4	760mm(29.9")	880mm(34.6")
			0.64m <sup>3</sup> (0.84yd <sup>3</sup> )	0.55m <sup>3</sup> (0.72yd <sup>3</sup> )	5	920mm(36.2")	1040mm(40.9")
			0.89m <sup>3</sup> (1.16yd <sup>3</sup> )	0.77m <sup>3</sup> (1.01yd <sup>3</sup> )	6	1220mm(48.0")	1340mm(52.8")
			1.05m <sup>3</sup> (1.37yd <sup>3</sup> )	0.90m <sup>3</sup> (1.18yd <sup>3</sup> )	6	1400mm(55.1")	1520mm(59.8")
			0.69m <sup>3</sup> (0.90yd <sup>3</sup> )	0.62m <sup>3</sup> (0.81yd <sup>3</sup> )	5	990mm(39.0")	-

: Heavy duty bucket

## 9. RECOMMENDED OILS

Use only oils listed below or equivalent.  
Do not mix different brand oil.

Service point	Kind of fluid	Capacity (U.S. gal)	Ambient temperature °C(,°F)						
			-20 (-4)	-10 (14)	0 (32)	10 (50)	20 (68)	30 (86)	40 (104)
Engine oil pan	Engine oil	16.5(4.3)	SAE 30						
			SAE 10W						
			SAE 10W-30						
			SAE 15W-40						
Swing drive	Gear oil	5(1.3)	SAE 85W-140						
Final drive		5.4 × 2 (1.4 × 2)							
Hydraulic tank	Hydraulic oil	Tank: 160(42.2) System: 240(63.4)	ISO VG 32						
			ISO VG 46						
			ISO VG 68						
Fuel tank	Diesel fuel	260(68.7)	ASTM D975 NO.1						
			ASTM D975 NO.2						
Fitting (Grease nipple)	Grease	As required	NLGI NO.1						
			NLGI NO.2						
Radiator (Reservoir tank)	Mixture of antifreeze and water 50 : 50	30(7.9)	Ethylene glycol base permanent type						

**SAE** : Society of Automotive Engineers

**API** : American Petroleum Institute

**ISO** : International Organization for Standardization

**NLGI** : National Lubricating Grease Institute

**ASTM** : American Society of Testing and Material