

# GROUP 6 STRUCTURE

## 1. CAB AND ACCESSORIES MOUNTING

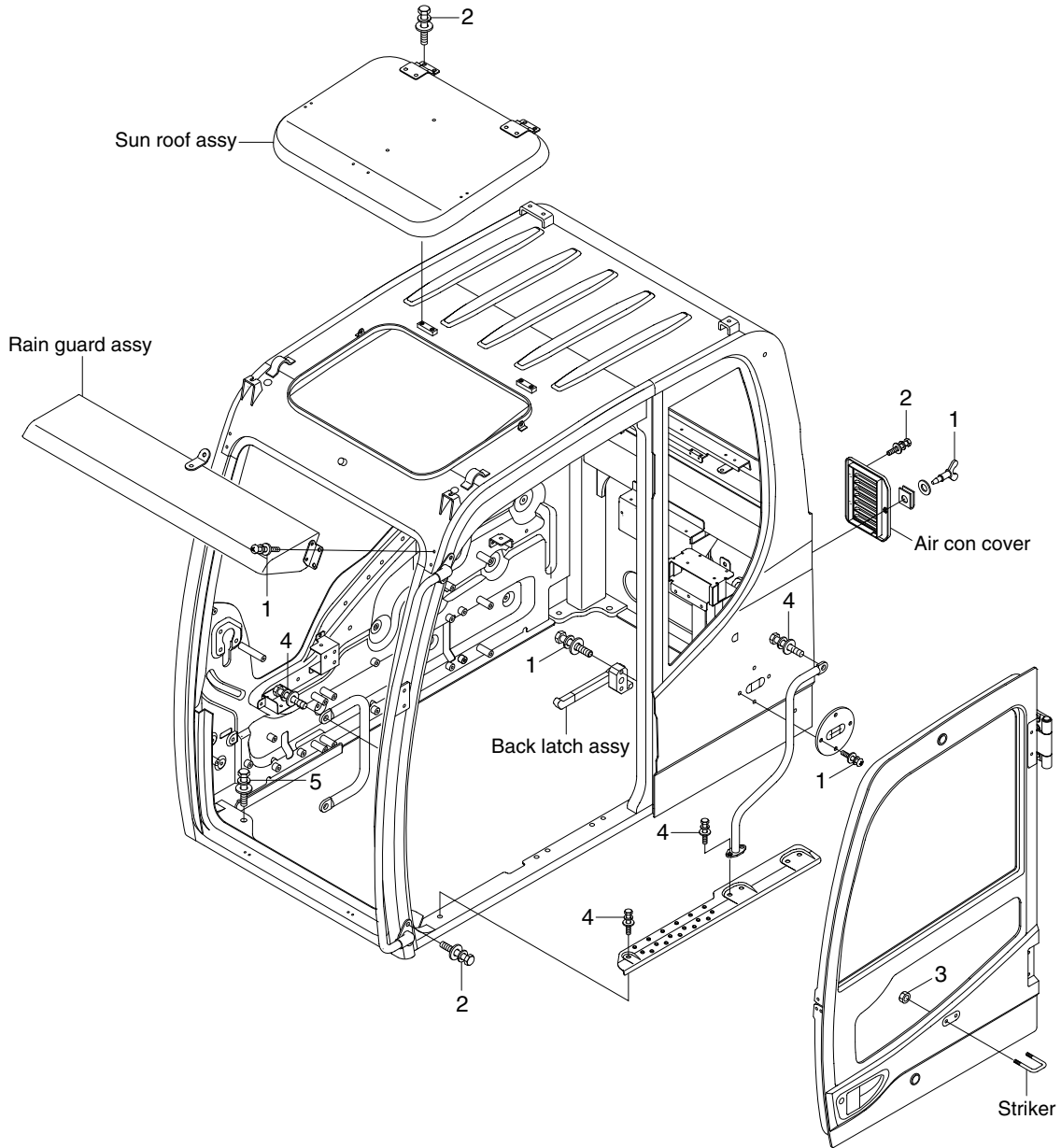

14W99CM10

· Tightening torque

Item	Size	kgf · m	kgf · m
1	M 6×1.0	1.44±0.3	10.4±2.2
2	M 8×1.25	2.5±0.5	18.1±3.6
3	M10×1.5	4.7±0.9	34±6.5

Item	Size	kgf · m	kgf · m
4	M10×1.5	6.9±1.4	49.9±10.1
5	M12×1.75	12.8±3.0	92.6±21.7

## 2. CAB INTERIOR MOUNTING

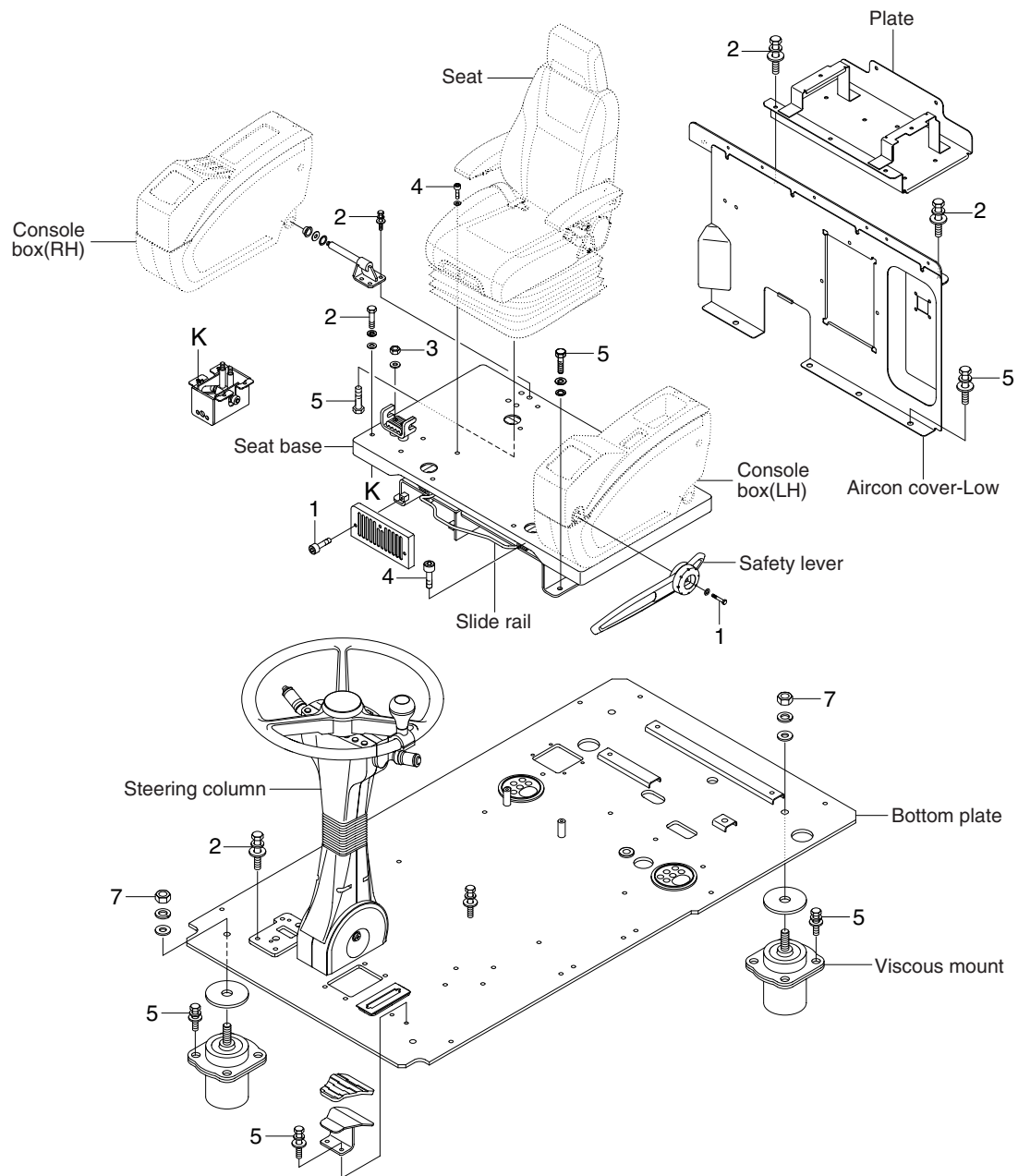

14W99CM11

### · Tightening torque

Item	Size	kgf · m	kgf · m
1	M 6×1.0	1.05±0.2	7.6±1.4
2	M 8×1.25	2.5±0.5	18.1±3.6
3	M 8×1.25	3.43±0.7	24.8±5.1

Item	Size	kgf · m	kgf · m
4	M 8×1.25	4.05±0.8	29.3±5.8
5	M10×1.5	6.9±1.4	49.9±10.1
6	M16×2.0	29.7±4.5	215±32.5

### 3. COWLING MOUNTING

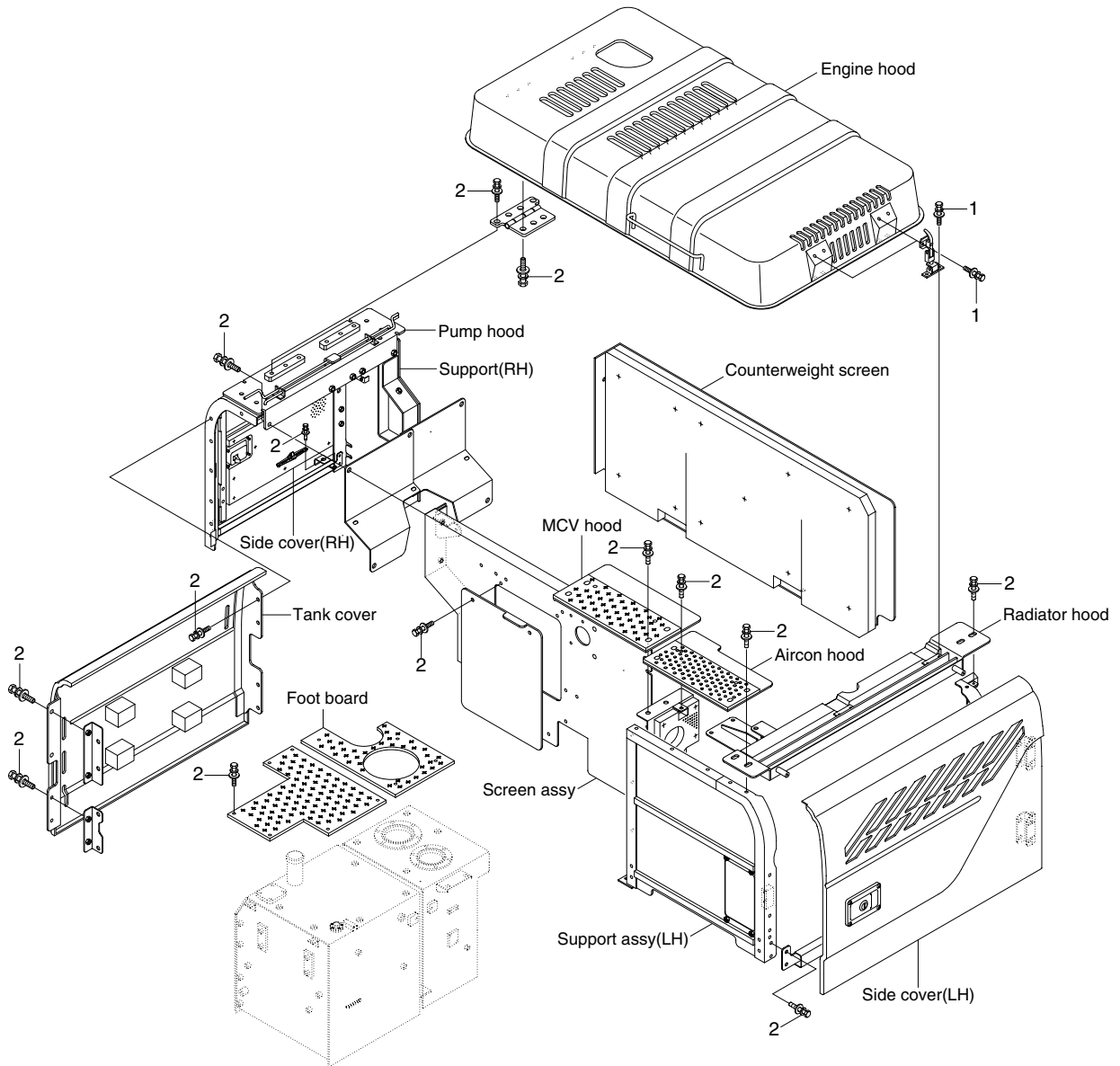

17W99CM12

· Tightening torque

Item	Size	kgf · m	kgf · m
1	M 8×1.25	1.05±0.2	7.6±1.4
2	M12×1.75	12.8±3.0	92.6±21.7

# COUNTERWEIGHT AND COVERS MOUNTING

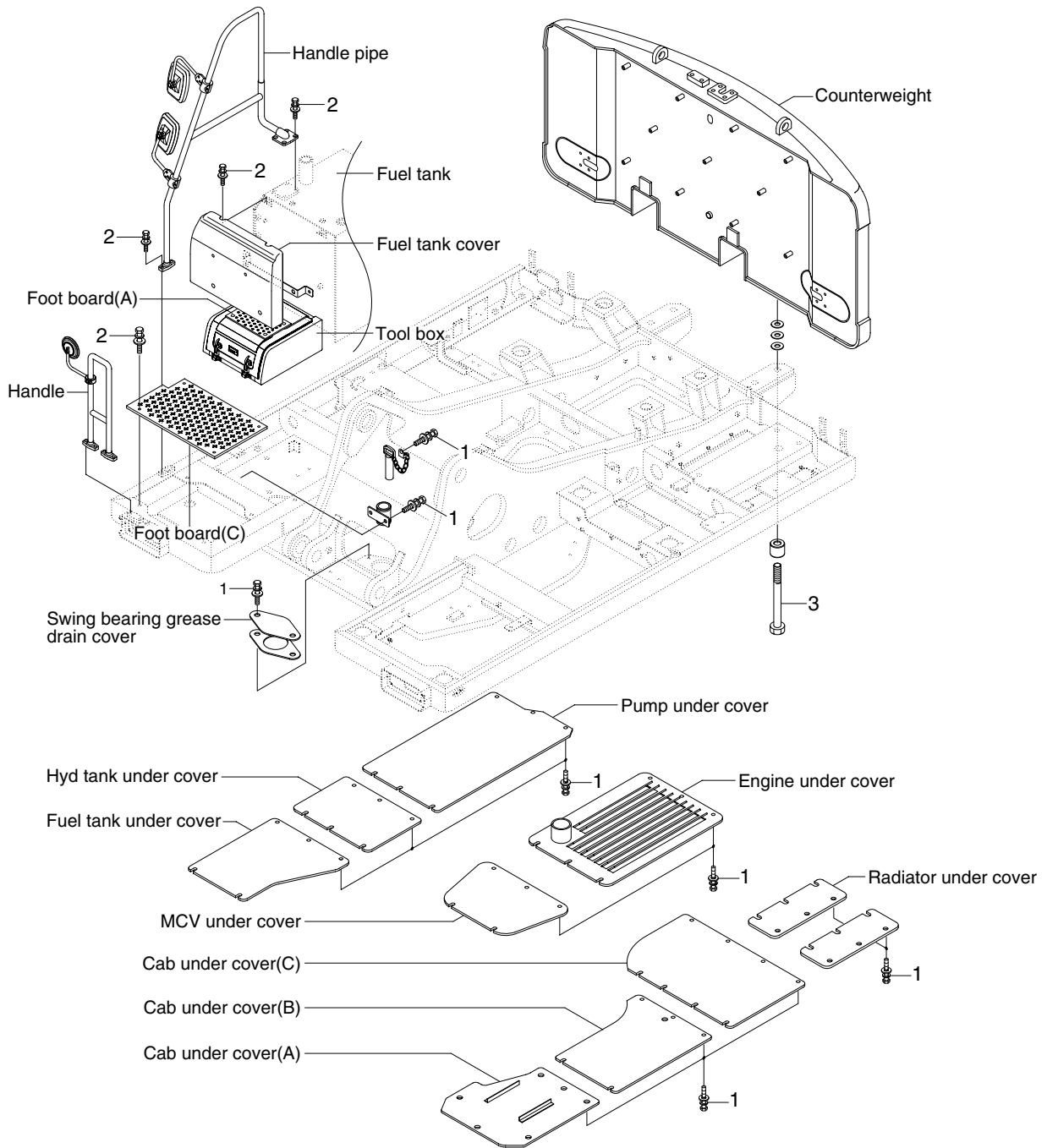

17W99CM13

## · Tightening torque

Item	Size	kgf · m	kgf · m
1	M10×1.5	6.9±1.4	49.9±10.1
2	M12×1.75	12.8±3.0	92.6±21.7

Item	Size	kgf · m	kgf · m
3	M30×3.0	199±30	1439±217