

GROUP 9 FRONT AXLE

1. REMOVAL FRONT AXLE

- 1) Propeller shaft mounting nut (1, M10)
 - Tightening torque : 5.9 ± 0.6 kgf · m
(42.7 ± 4.3 lbf · ft)
- 2) Wheel nut (2, M22)
 - Tightening torque : 60^{+0}_{-5} kgf · m
(433^{+0}_{-36} lbf · ft)
- 3) Oscillating cylinder supporting mounting bolt (3, M16)
 - Tightening torque : 29.6 ± 3.2 kgf · m
(214 ± 23.1 lbf · ft)
- 4) Pipe assy (4)
- 5) Hose assy (5)
- 6) Front axle weight : 630 kg (1390 lb)

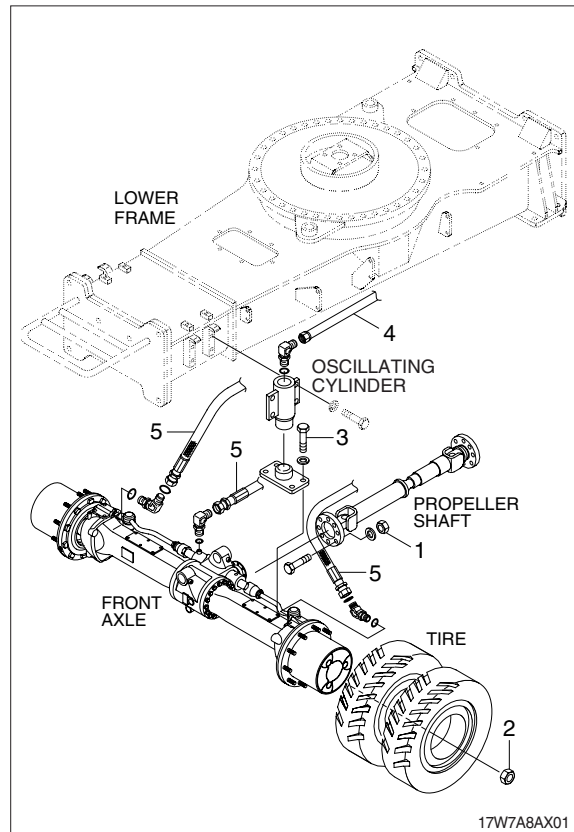

3. GENERAL INSTRUCTIONS

1) GENERAL WORKING INSTRUCTIONS

- (1) This manual has been developed for the skilled serviceman, trained by the ZF-Passau.
- (2) During all operations, pay attention to cleanliness and skilled working.
Therefore, axle removed from the machine, must be cleaned prior to open them.
- (3) We assume that the special tools, specified by ZF, will be used.
The special tools are available from ZF-Passau.
- (4) After the disassembly, all components must be cleansed, especially corners, cavities and recesses of housing and covers.
- (5) The old sealing compound must be carefully removed.
- (6) Check lubricating holes, grooves and pipes for free passage. They must be free of residues, foreign material or protective compounds.
- (7) The latter refers especially to new parts.
- (8) Parts which have been inevitably damaged in a disassembly operation, must be generally replaced by new ones, e.g. rotary seal rings, O-rings, U-section rings, cap boots, protective caps etc..
- (9) Components such as roller bearings, thrust washers, synchronizing parts etc. which are subject to normal wear in automotive operation, must be checked by the skilled Serviceman.
He will decide if the parts can be reused.
- (10) For the heating of bearings etc., hot plates, rod heaters or heating furnaces must be used.
- (11) Never heat parts directly with the flame. An auxiliary solution would be to immerse the bearing in a vessel filled with oil, which is then heated with the flame.
In this way, damage to the bearings could be avoided.
- (12) Ball bearings, covers, flanges and parts like that must be heated to about 90 to 100°C.
- (13) Hot-mounted parts must be reset after cooling in order to assure a proper contact.
- (14) Before pressing shafts, bearings etc. in position, both parts must be lubricated.
- (15) During to reassembly, all specified adjustment values, testing specifications and tightening torque must be respected.
- (16) After the repair, units are filled up with oil.
- (17) After the oil filling, the oil level plugs and oil drain plugs must be tightened to the specified tightening torque.

2) IMPORTANT INSTRUCTIONS CONCERNING THE LABOUR SAFETY

- (1) In principle, repairers are themselves responsible for the labour safety.
- (2) The observance of all valid safety regulations and legal rules is a precondition to prevent damage to individuals and products during the maintenance and repair operations.
- (3) Before starting the work, the repairers have to make themselves familiar with these regulations.
- (4) The proper repair of these products requires especially trained personnel.
- (5) The repairer himself is obliged to provide for the training.

3) LUBRICANT SPECIFICATIONS

- (1) Gear oils with limited - slip additives.
- (2) API GL-5
- (3) MIL-L-2105D (SAE 85W-90, 85W-140 with LS-Additive)

4) BRAKE LINING WEARING TEST

(1) The measurement of wear on the multi-disc brake only gives limited information on the total state of the plate pack without disassembling the output.

Make measurement of lining wear at least once per year, in particular, however, in case of a different braking behaviour, like :

- Braking noises
- Reduced braking power
- Different deceleration
- Different brake oil level
- Different braking pressure

※ To avoid injury when opening the oil drain/ oil filler plug (1), due to a possible pressure build-up in the planetary carrier bring drain hole to topmost position (12 o'clock) and carefully unscrew oil drain and filler plug (1).

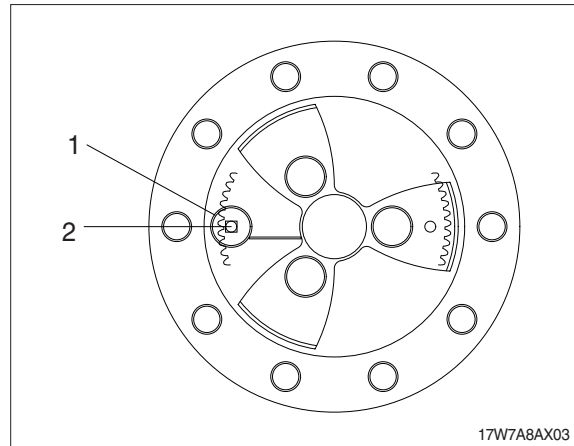

(2) Then turn output until oil filler / oil drain hole (2) is on 9 o'clock position.

- 1 = Oil filler-/oil drain hole
- 2 = Gauge hole ($\varnothing = 10$ mm) in ring gear 9 o'clock position
- 3 = Dial indicator with solenoid support
- 4 = Planetary carrier
- 5 = Ring gear
- 6 = Piston
- 7 = Plate pack
- X = Piston stroke

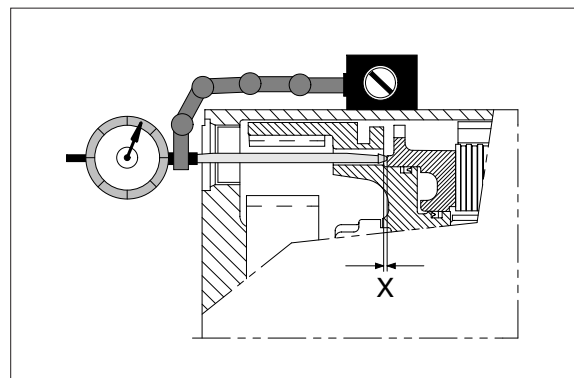
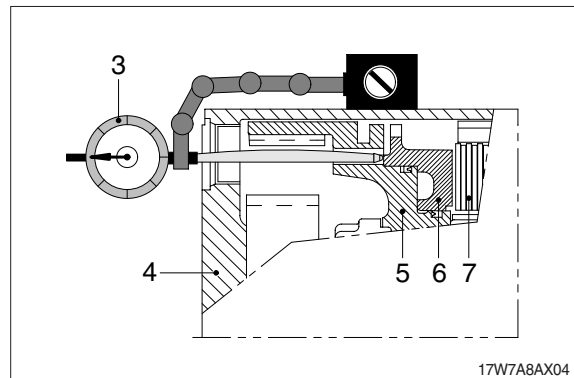

3. DISASSEMBLY

1) STEERING

(1) Fix the axle to the assembly truck.

(S) Assembly truck 5870 350 000

(S) Support 5870 350 106



17W98FA001

(2) Loosen locknut.

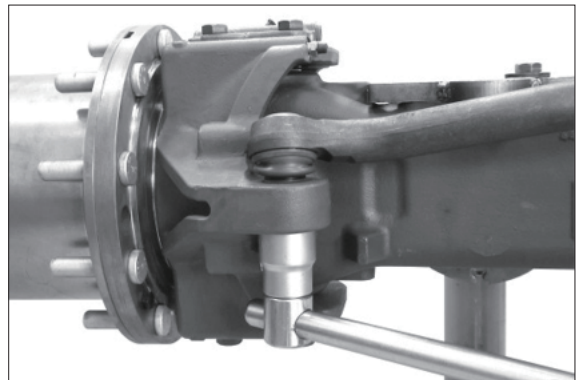

17W98FA002

(3) Force out tie rod from bevel seat.

※ Use suitable mandrel (brass or aluminum).

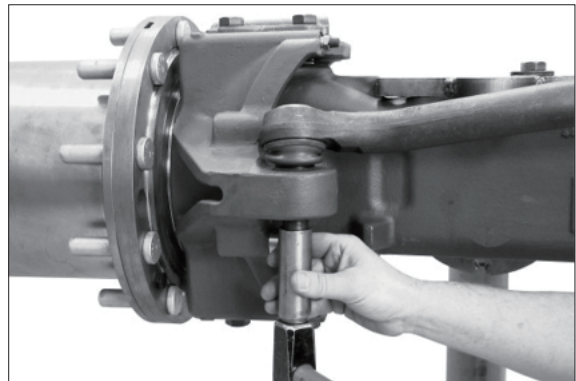

17W98FA003

(4) Warm up piston rod by means of hot air blower.

※ Axial joint is installed with Loctite no. 243.

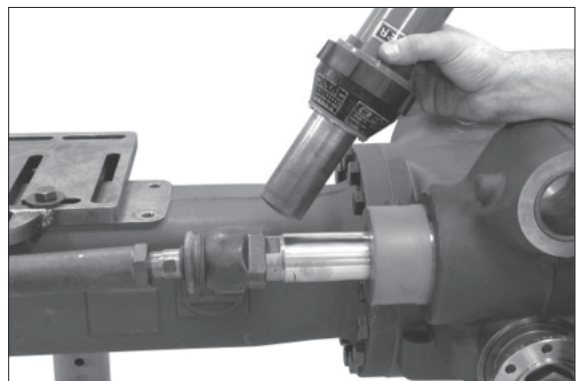

17W98FA004

(5) Separate both tie rods from piston rod.

- ※ If work is just to be done on piston rod, guide or sealing elements, no disassembly of the steering cylinder assy is required.

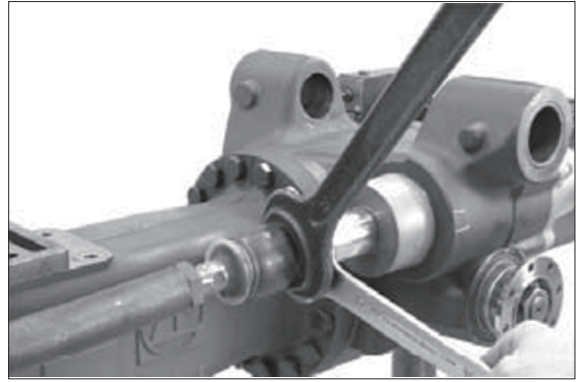

17W98FA005

(6) Loosen hexagon screws.

- ※ Mark radial installation position of steering cylinder to axle housing – assembly aid.

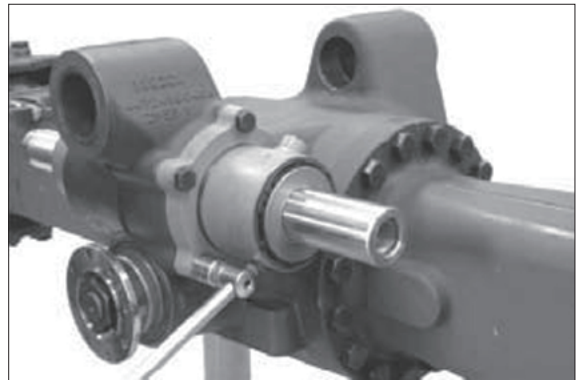

17W98FA006

(7) Drive out steering cylinder assy from axle housing hole.

- ※ Use a plastic hammer.

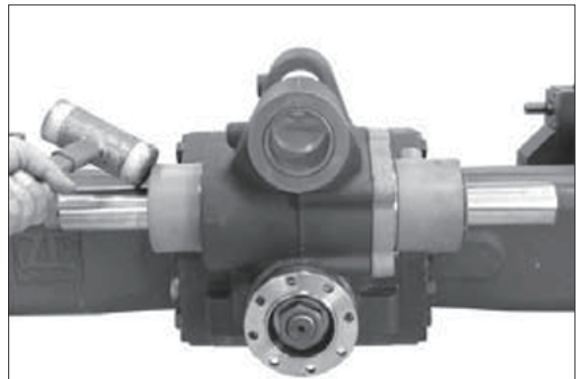

17W98FA007

(8) Unsnap the retaining ring and remove the releasing flange.



17W98FA008

(9) Unsnap retaining ring.



17W98FA009

(10) Push/force the brake head into the cylinder tube, until the retaining ring (see figure FA011) can be removed.



17W98FA010

(11) Unsnap retaining ring.

Then drive out piston rod together with brake head from cylinder tube.



17W98FA011

(12) Pull off brake head from the piston rod.

Then remove all sealing elements from piston rod, brake head and cylinder tube.



17W98FA012

2) OUTPUT

- (1) Loosen screw plug and drain oil from the axle.

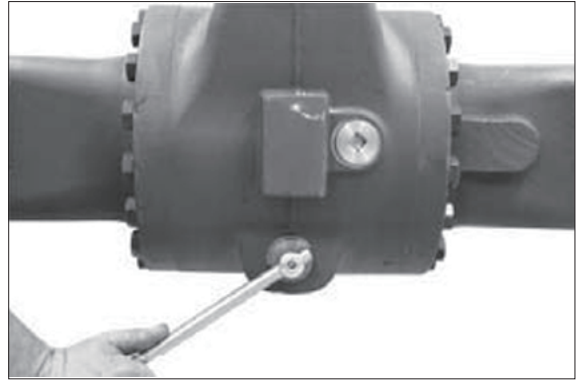

17W98FA013

- (2) Loosen screw plug and drain oil from the planetary carrier.

- ※ To avoid injury due to a possible pressure build-up in the oil system of the planetary carrier, bring oil filler and control plug to 12 o'clock position and carefully unscrew. Then bring drain hole to 6 o'clock position and drain oil.
- ※ Use suitable collecting basin environmental protection.



17W98FA014

(3) Planetary carrier

Loosen both hexagon screws and separate planetary carrier from hub.

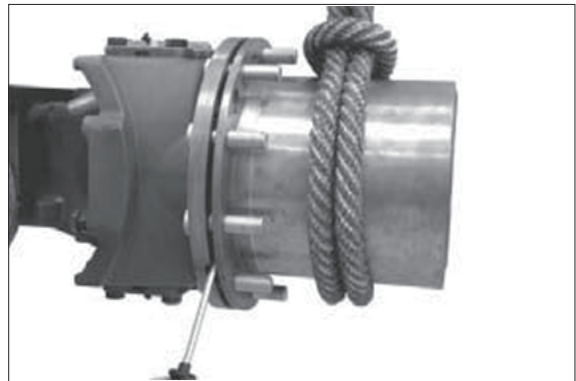

17W98FA015

- (4) Unsnap retaining ring.

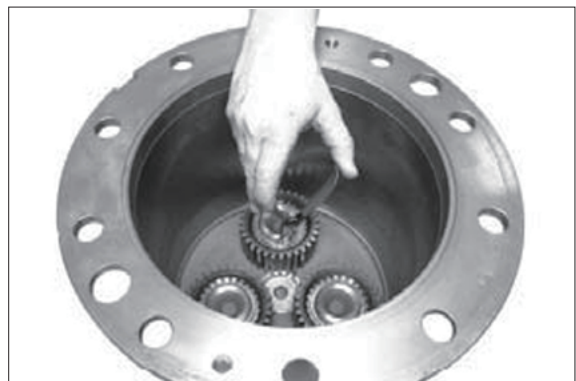

17W98FA016

- (5) Pull off planetary gear together with cylindrical roller bearing.

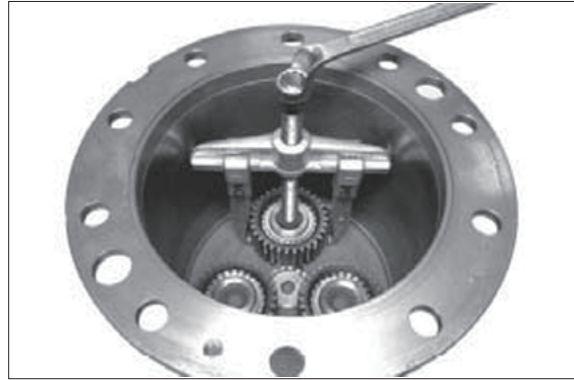

17W98FA017

- (6) **Brake**
Unsnap retaining ring and remove both thrust washers.

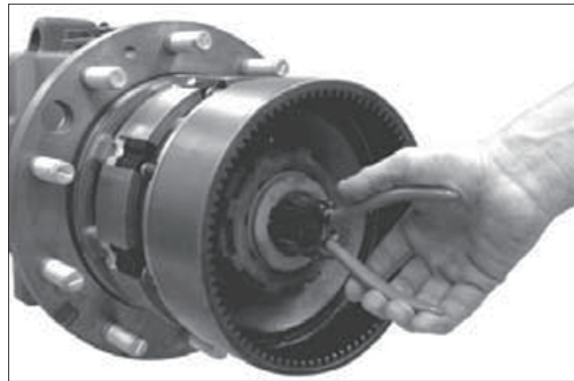

17W98FA018

- (7) Loosen cylindrical screw (slotted nut fixing).

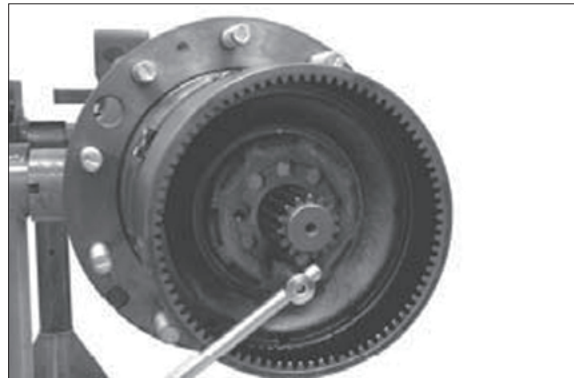

17W98FA019

- (8) Loosen slotted nut.
(S) Socket wrench 5870 656 097



17W98FA020

(9) Press off ring gear together with piston from joint housing.

(S) Assembly lever 5870 345 036

※ Pay attention to releasing O-ring (arrow).

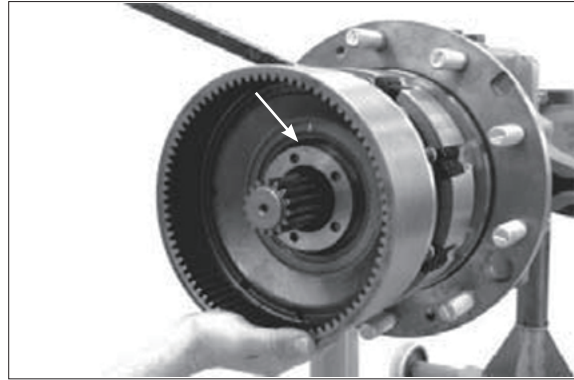

17W98FA021

(10) Loosen hexagon screws and remove releasing spring sleeves and compression springs.



17W98FA022

(11) Press off piston from ring gear.



17W98FA023

(12) Remove sealing elements from the annular grooves (see arrows) of the ring gear.



17W98FA024

(13) Remove disk package.

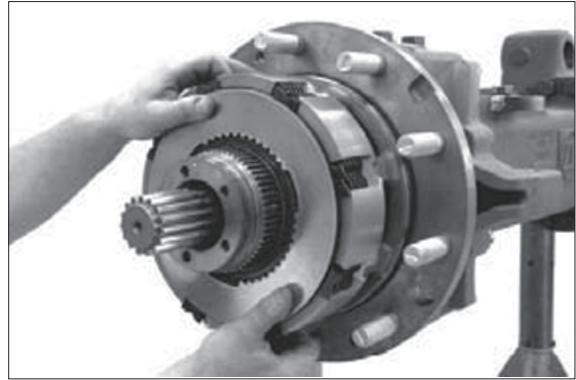

17W98FA025

(14) Remove O-ring (see arrow) and lift off disk carrier from the joint housing.

(S) Adjusting device 5870 400 001

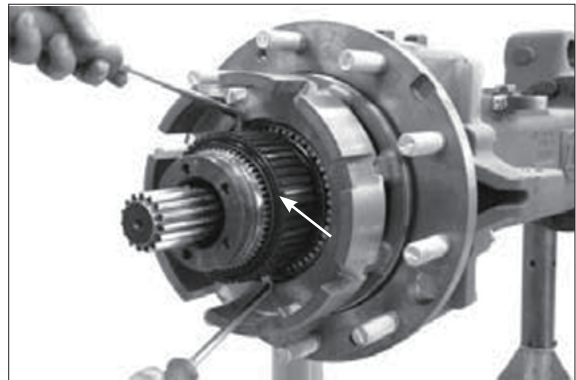

17W98FA026

(15) Hub

Remove O-ring (see arrow).

Secure hub with lifting bracket (S) and pull from joint housing by means of a two armed puller.

(S) Lifting bracket 5870 281 043

(S) Pressure piece 5870 100 067

※ Pay attention to releasing bearing inner ring.

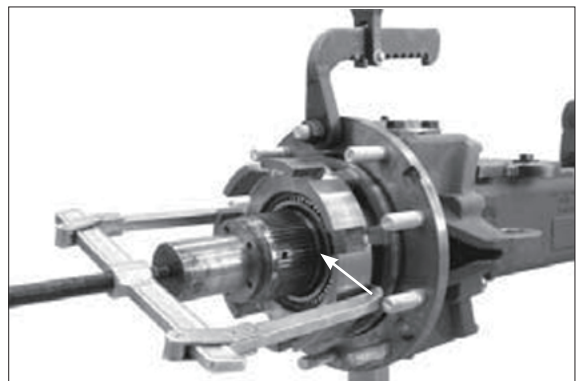

17W98FA027

(16) Use a lever to lift-off shaft seal ring (see arrow) from hub hole and force both bearing outer rings out of the hub.



17W98FA028

(17) Remove spacer bushing.

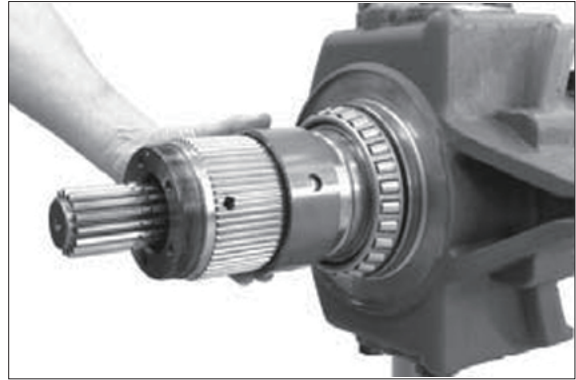

17W98FA029

(18) Pull tapered roller bearing from joint housing.

(S) Grab sleeve 5873 004 026

(S) Pressure piece 5870 100 067

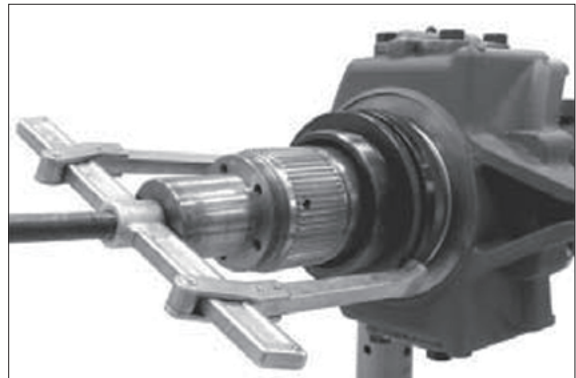

17W98FA030

(19) Knuckle housing

Loosen threaded joint and remove upper bearing pin.

- ※ Pay attention to releasing O-ring.
- ※ Remove lower bearing pin only after securing the knuckle housing (see figure FA032).

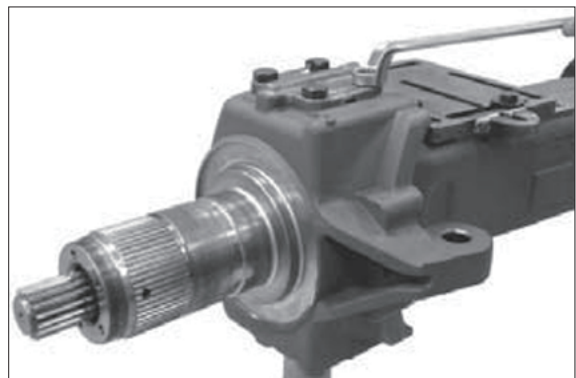

17W98FA031

(20) Secure knuckle housing by means of lifting tackle.

Then loosen threaded joint and remove lower bearing pin.

(S) Eyebolts (M 18) 5870 204 085

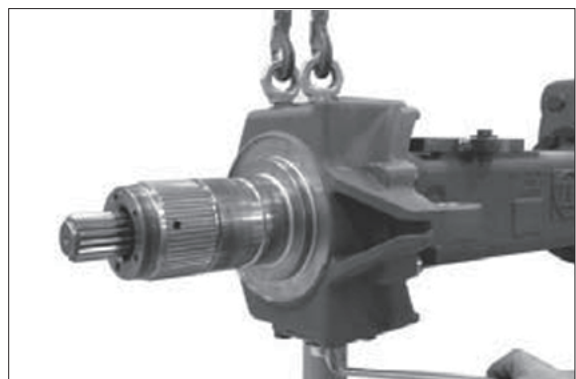

17W98FA032

(21) Use lever to remove tapered roller bearing (1) from bearing pin, remove releasing sealing cap (2) and the O-ring lying behind.

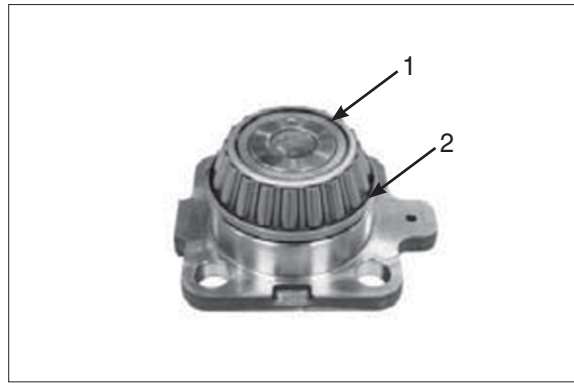

17W98FA033

(22) Separate knuckle housing with double u-joint shaft from the axle housing.

※ Pay attention to shaft seal ring in the axle housing risk of damage.

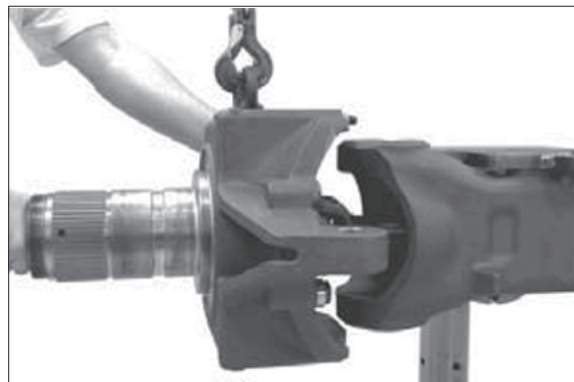

17W98FA034

(23) Pull out double u-joint shaft from knuckle housing.

※ Pay attention to shaft seal ring in the knuckle housing risk of damage.

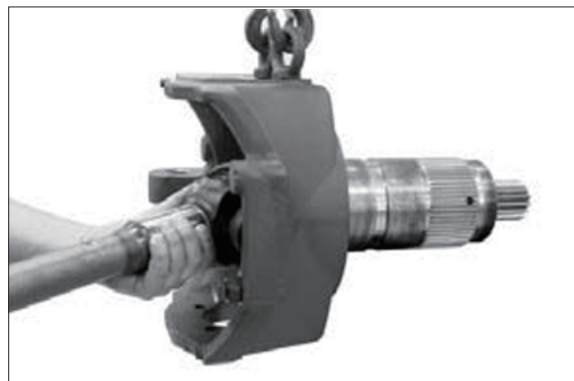

17W98FA035

(24) Pull out shaft seal ring and afterwards the bushing behind from the axle housing.

(S) Internal extractor 5870 300 017

(S) Counter support 5870 300 020



17W98FA036

(25) Pull out shaft seal ring and afterwards the bushing behind from the axle housing.

(S) Internal extractor 5870 300 017

(S) Counter support 5870 300 020

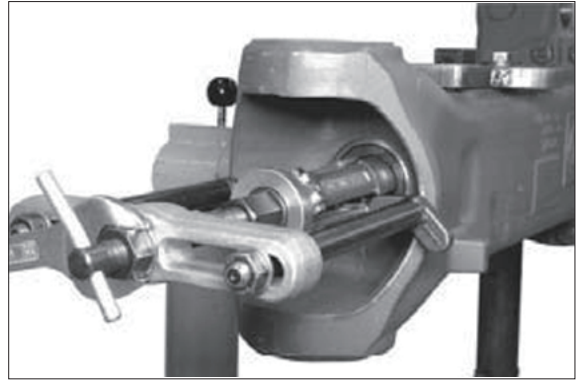

17W98FA037

(26) Pull out both bearing outer rings from the pivot bearing holes.

(S) Internal extractor 5870 300 019

(S) Counter support 5870 300 020

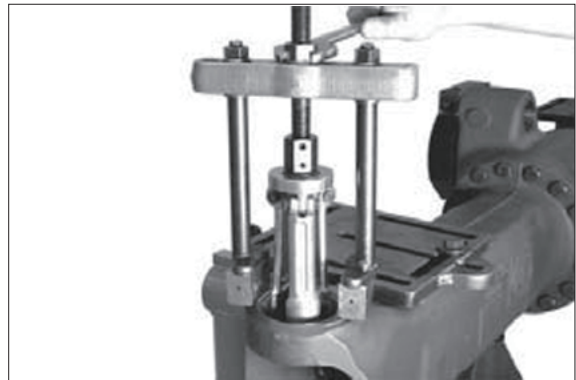

17W98FA038

(27) Output assy

※ If work is required on the differential or pinion, you may disassembly the output as complete unit (operation FA039 and FA040).

Secure output assy by means of lifting tackle (S).

(S) Lifting bracket 5870 281 043

Then loosen threaded joints of both bearing pins.

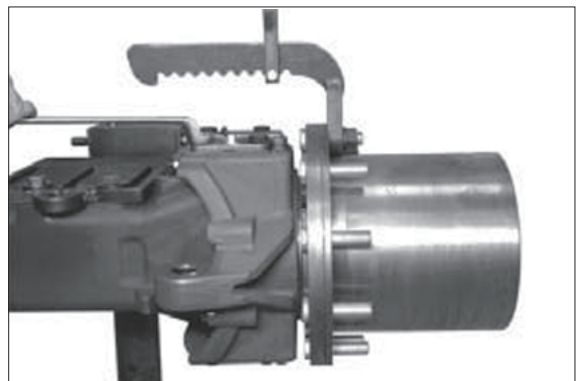

17W98FA039

(28) Remove both bearing pins and separate the output assy from the axle housing.

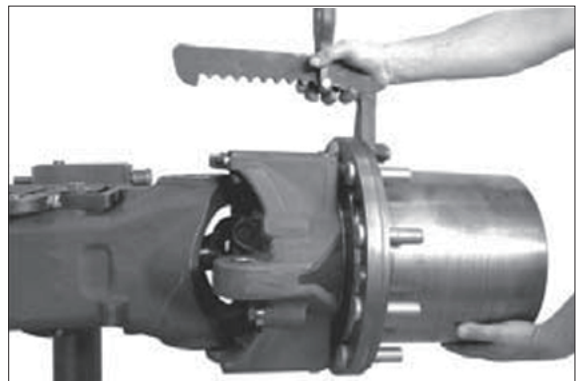

17W98FA040

3) INPUT

- (1) Support axle to axle drive housing (see arrow).

Then secure axle housing (crown wheel side) by means of lifting tackle and loosen threaded joint.

Then separate axle housing from axle drive housing.

- ※ Pay attention to possibly releasing differential.

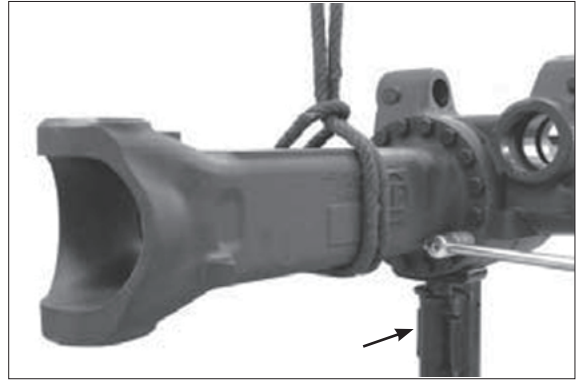

17W98FA041

- (2) Pull bearing outer ring (arrow 1) from the bearing hole and remove releasing shim.
Then remove O-ring (arrow 2).

(S) Striker 5870 650 004

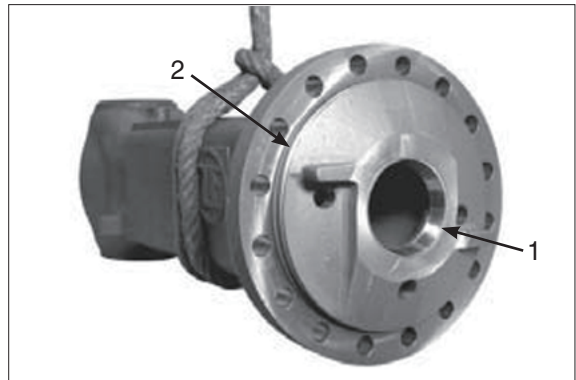

17W98FA042

- (3) Lift differential out of the axle drive housing.

- ※ Disassembly of the differential is described as of page 8-189.

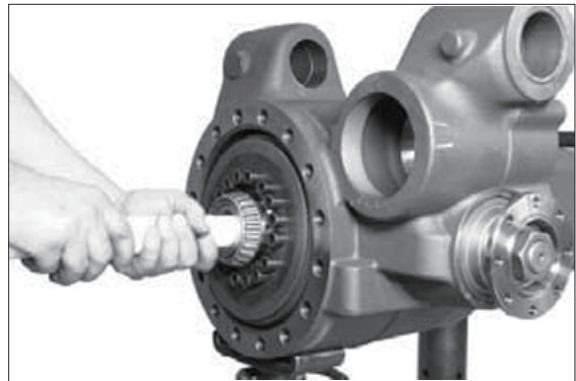

17W98FA043

- (4) Use striker (S) to pull bearing outer ring out of the bearing hole (axle housing) and remove releasing shim.

(S) Striker 5870 650 004

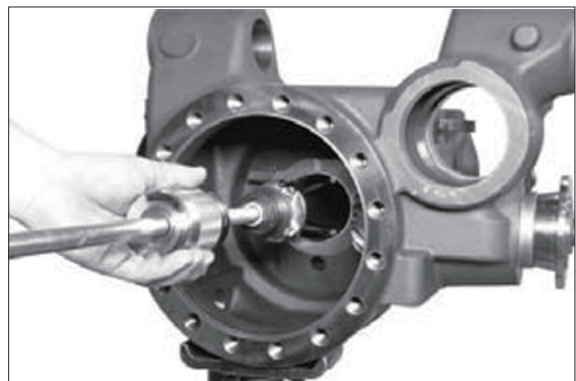

17W98FA044

- (5) Warm up hexagon nut by means of hot air blower.
Then loosen hexagon nut and remove the releasing shim.

(S) Clamping fork 5870 240 025

- ※ Hexagon nut is installed with Loctite no. 262.

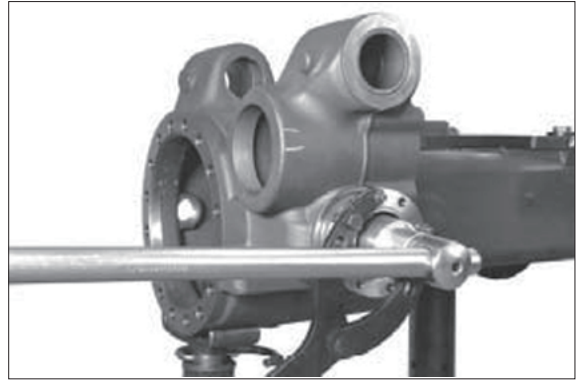

17W98FA045

- (6) Pull input flange from pinion.
If necessary, remove screen sheet from flange.



17W98FA046

- (7) Use a lever to remove the shaft seal ring from the housing hole.



17W98FA047

- (8) Force out input pinion and remove releasing roller bearing.

- ※ Use plastic hammer.
※ If tapered roller bearings should not be replaced, pay attention that the outer bearing inner ring with all its rolls is in contact with bearing outer ring when forcing out the input pinion.



17W98FA048

(9) Remove spacer ring.



17W98FA049

(10) Press roller bearing from input pinion.

(S) Grab sleeve 5873 001 037

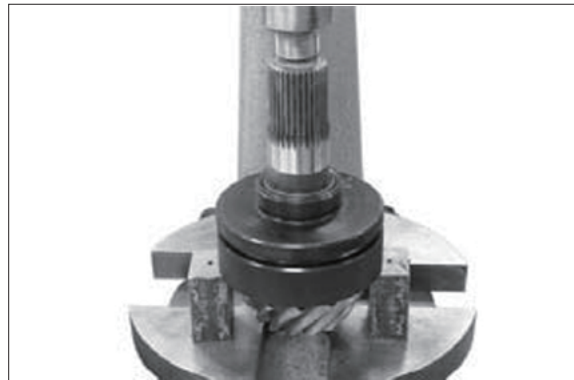

17W98FA050

(11) Pull off outer bearing outer ring from bearing hole.

(S) Internal extractor 5870 300 019

(S) Counter support 5870 300 020



17W98FA051

(12) Force out bearing outer ring from the inner bearing hole pay attention to the shim behind.

※ Mark shim (with regard to position/bearing allocation) assembly aid.

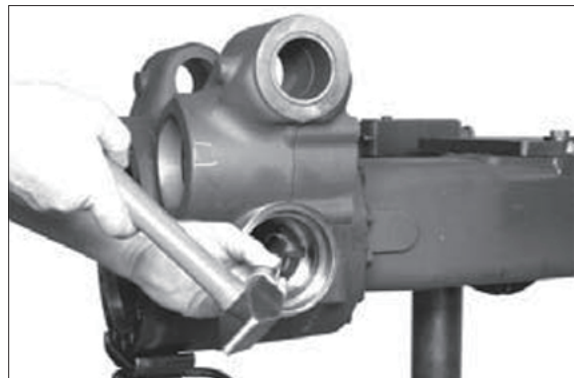

17W98FA052

(13) If necessary, provide bushings with a separating slot (see arrow) and remove from holes.

※ Bushings are destroyed by this.

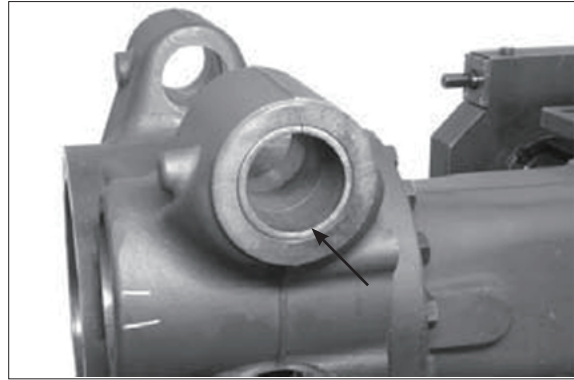

17W98FA053

4) DIFFERENTIAL

(1) Differential - versions:
b = Constant spacers

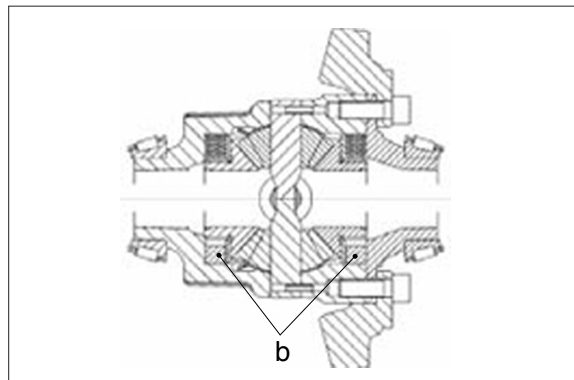

17W98FA054

(2) Pull both tapered roller bearings from differential carrier.

(S) Grab sleeve	5873 011 019
(S) Basic tool	5873 001 000
(S) Pressure piece	5870 100 009



17W98FA055

(3) Use press to fix differential and loosen threaded joint crown wheel / differential carrier.

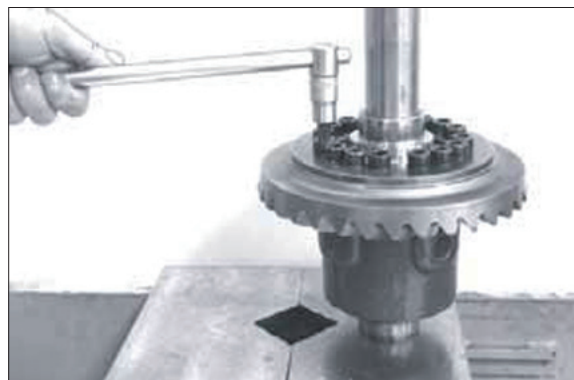

17W98FA056

(4) Press crown wheel from differential.



17W98FA057

(5) Remove single parts.
Remove axle bevel gear together with thrust washer and constant spacer from the differential carrier.



17W98FA058

(6) Force slotted pins (considering position "X", see subsequent sketch FA060) into the spider shafts.



17W98FA059

(7) Comment on sketch:
1 = Differential carrier
2 = Spider shafts (short)
3 = Slotted pins
4 = Differential bevel gears
5 = Axle bevel gear
X = Position of the slotted pin to force out the spider shafts

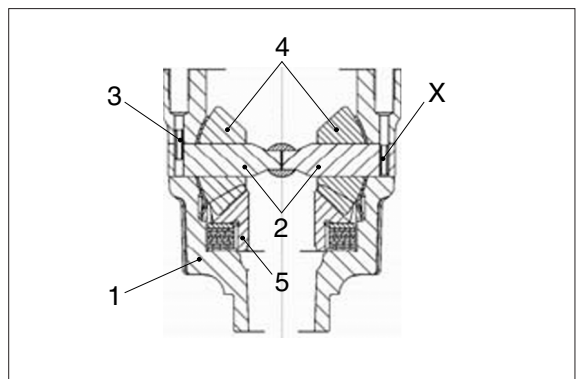

17W98FA060

(8) Force out both spider shafts (short).



17W98FA061

(9) Remove all single parts.



17W98FA062

4. REASSEMBLY

1) DIFFERENTIAL

(1) b = Constant spacers

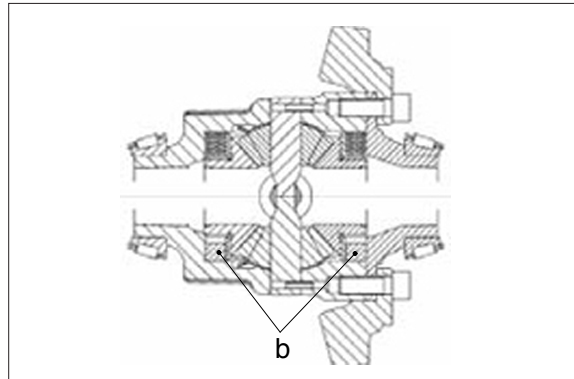

17W98FA054

(2) All outer and inner disks are replaced by a constant spacer (see figure FA066).

1 = Axle bevel gear

2 = Pressure disk

3 = Constant ring

※ No measuring / setting of the axial play of the two axle bevel gears is required, therefore single parts can be immediately oiled.

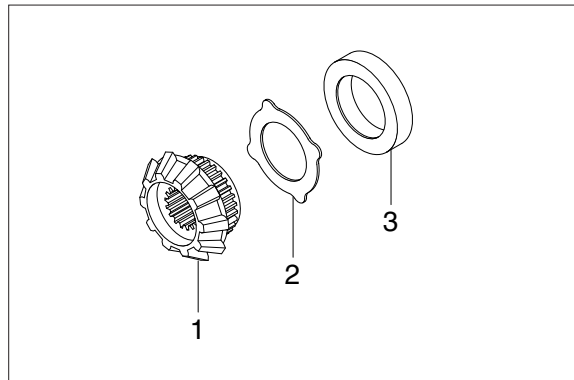

17W98FA065

(3) Insert premounted axle bevel gear into the differential carrier.



17W98FA066

(4) Insert differential bevel gears (1) with thrust washers (2) and fix with spider shafts (3 and 4).

※ Pay attention to radial installation position of the thrust washers.



17W98FA067

(5) Check axial play of the axle bevel gear $0.0 \sim 0.15$ mm.

※ If the axial play is not within the specified tolerance, correct with the corresponding outer disks.

After the setting procedure separate the single parts again.

Then oil and reassemble all single parts again.

※ Make sure that thickness and arrangement of the second disk package are identical (figure FA071).



17W98FA068

(6) Fix both spider shafts (short) by means of slotted pins (considering installation dimension, see sketch FA070).



17W98FA069

(7) Comment on sketch:

1 = Slotted pin

2 = Spider shaft (short)

3 = Spider shaft

4 = Differential carrier

X = Installation dimension 34 ± 0.5 mm

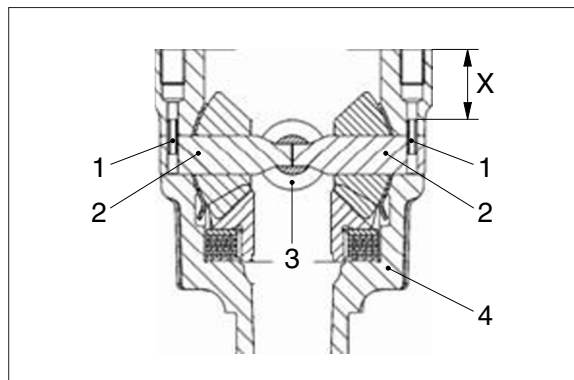

17W98FA070

(8) Mount second axle bevel gear with thrust washer and constant spacer (see also figure FA065).

※ Mount the pressure disk with the coated surface showing to the outer disk.

※ Thickness and arrangement of the disk package must be identical on both sides of the differential gear.



17W98FA071

(9) Check axial play of the second axle bevel gear 0.0~0.15 mm.

※ If the axial play is not within the specified tolerance, correct with the corresponding outer disks.

After the resetting procedure remove the second axle bevel gear together with the disk package from the differential carrier.

Then oil and reassemble all single parts.



17W98FA072

(10) Mount two adjusting screws (S) and insert cover.

(S) Adjusting screws (M12×1.5)

5870 204 027



17W98FA073

(11) Press crown wheel onto the cover / differential carrier until contact position is obtained.



17W98FA074

(12) Fix differential with press and tighten crown wheel with cylindrical screws.

Tightening torque (M12×1,5/12.9)

. MA = 145 Nm



17W98FA075

(13) Press on both bearing inner rings until contact is obtained.

- ※ Use an appropriate support (arrow differential may not be supported on the bearing cage).

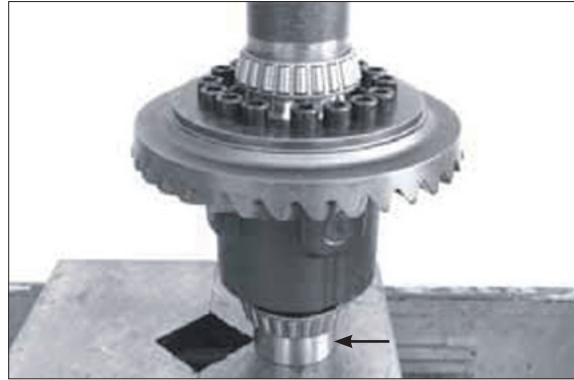

17W98FA076

2) INPUT

(1) Input pinion

- ※ The following measuring procedures must be carried out with utmost accuracy. Inaccurate measurements lead to an incorrect contact pattern and another disassembly and reassembly of the input pinion is required.

(2) Determine thickness of the shim to obtain a correct contact pattern

Read dimension I from the axle drive housing.

Dimension I e.g. 154.05 mm

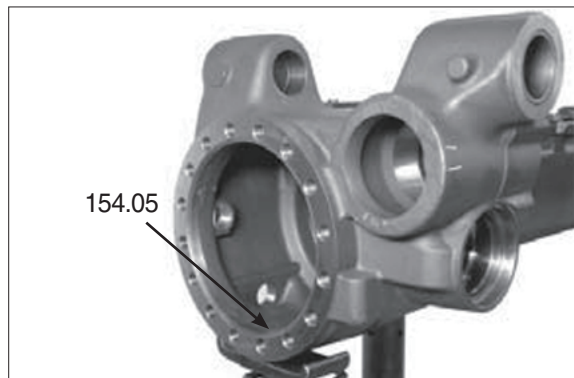

17W98FA077

(3) Read dimension II (pinion dimension).

Dimension II e.g. 116.00 mm

In case of a + or – deviation of the pinion dimension for production reasons the relevant value is marked by hand on the pinion.

Pinion dimension (without + or – deviation) = 116.0 mm

Pinion dimension with an indicated + 0.1 deviation = 116.1 mm

Pinion dimension with an indicated – 0.1 deviation = 115.9 mm

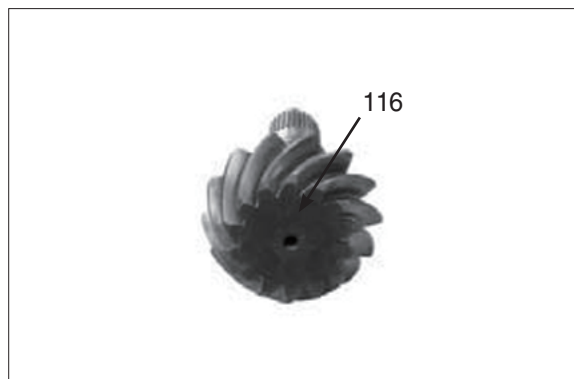

17W98FA078

(4) Determine dimension III (bearing width).

※ Make sure that the rollers are located without any play (rotate bearing g inner ring several times in both directions roller setting).

Since the installed roller bearing is subject to a pre-load in installation position, consider an experience deduction of 0.1 mm.

Dimension III, e.g. 36.60 mm – 0.1 mm
 = 36.50 mm

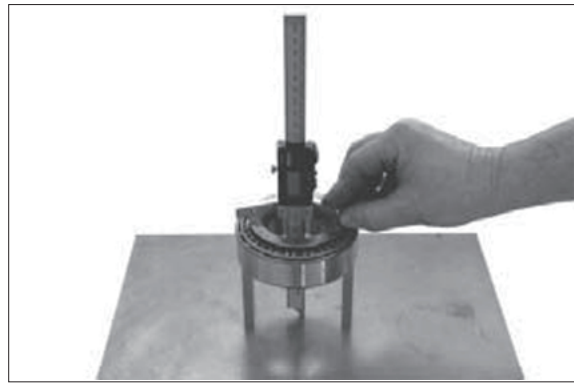

17W98FA079

(5) Calculation example "B" :

Dimension I 154.05 mm
 Dimension X - 152.50 mm
 Difference = shim s = 1.55 mm

Insert the determined shim (e.g. s = 1.55 mm) into the inner bearing hole.

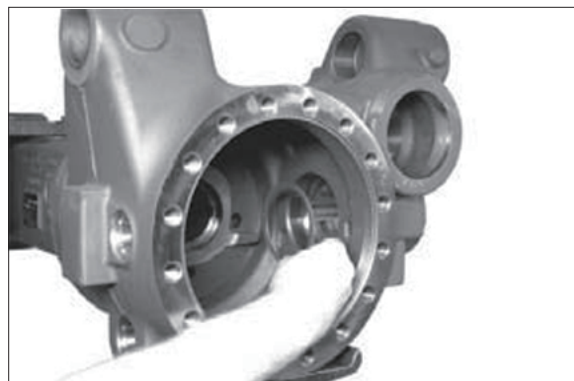

17W98FA080

(6) Undercool bearing outer ring (see arrow) and bring into contact position in the bearing hole by using the assembly fixture (S).

(S) Assembly fixture 5870 345 049
 (S) Pressure ring 5870 345 056

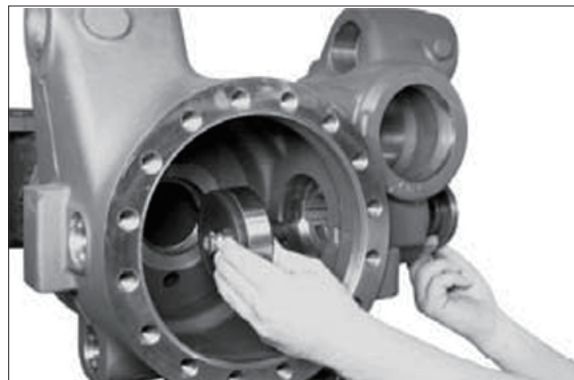

17W98FA081

(7) Undercool outer bearing outer ring and insert into bearing hole until contact is obtained.

(S) Assembly fixture 5870 345 049
 (S) Pressure ring 5870 345 056



17W98FA082

(8) Setting of rolling torque of the input pinion bearing 1.0 ... 3.0 Nm (without shaft seal ring)

Warm up roller bearing and insert until contact is obtained.

※ Adjust bearing after cooling down.



17W98FA083

(9) Insert spacer ring (e.g. $s = 16.96$ mm).

※ According to our experience, the necessary rolling torque is obtained when reusing the spacer ring which has been removed during disassembly (e.g. $s = 16.96$ mm).

A later check of the rolling torque, however, is absolutely necessary.



17W98FA084

(10) Insert the preassembled input pinion into the axle housing and mount the heated roller bearing until contact is obtained.

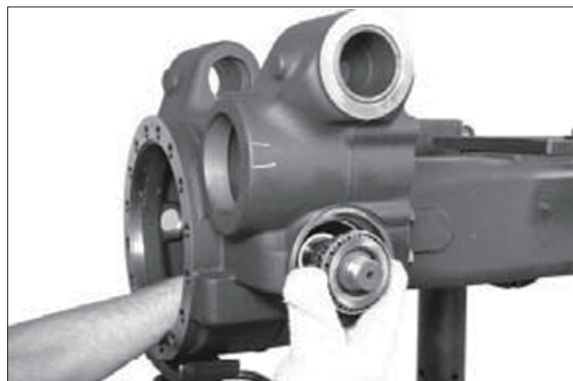

17W98FA085

(11) Press screen sheet (see arrow) onto the input flange until contact is obtained.

※ The shaft seal ring is mounted only after contact pattern check.



17W98FA086

(12) Mount input flange, fix with disk and hexagon nut.

Tightening torque (M30x1,5)
..... MA = 600 Nm

(S) Clamping fork 5870 240 025

- ※ During the tightening process rotate the input pinion several times in both directions.

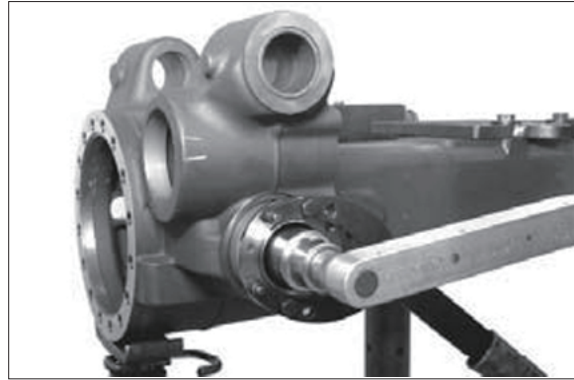

17W98FA087

(13) Check rolling torque (1.0 ... 3.0 Nm without shaft seal ring).

- ※ When installing new bearings try to achieve the upper value of the rolling torque.
- ※ In case of deviations from the necessary rolling torque correct with a corresponding spacer ring (Figure FA084) as specified below.

Insufficient rolling torque
install thinner spacer ring
Excessive rolling torque
install thicker spacer ring.



17W98FA088

(14) Determine shim for setting the bearing rolling torque (differential bearing) and backlash (bevel gear set).

- ※ The required shims must be determined on the basis of the read value (test dimension / crown wheel) and the corresponding specifications of the table next page : (KRS – SET – RIGHT) :
Read test dimension from crown wheel rear.



17W98FA089

- ※ Test dimension "70" is stamped into the crown wheel rear. Without + or deviation specification, this corresponds to test dimension / Actual value "70" in the table below.
According to this value the necessary shims are allocated in the table next page.

※ In case of + or – deviation of the test dimension for production reasons, it is additionally signed on the crown wheel rear (e.g. - 20 or - 10 . 10 or 20) .

※ In accordance with this deviation the necessary shims are allocated in the below table.

(15) Comment on sketch:

1 = Crown wheel 2 = Differential carrier

3 = Shim 4 = Shim
(crown wheel side) (diff. carrier side)

5 = Axle housing 6 = Axle housing

7 = Axle drive housing 8 = Input pinion

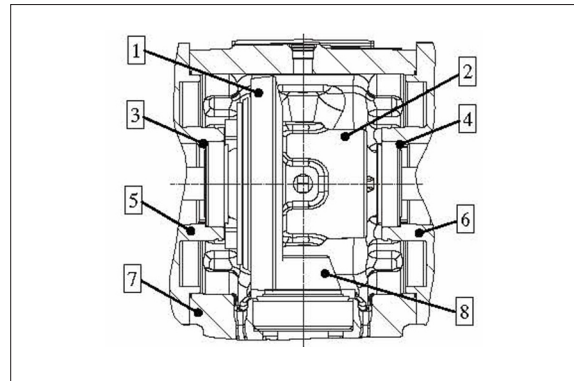

17W98FA090

Setting disks for differential					
Test dimension/Marking of crown wheel 70 and deviation	-20	-10	0	10	20
Result → Test dimension / Act. value	69.80	69.90	70.0	70.10	70.20
Shim/Diff. carrier side Required disk thickness	0.95	1.05	1.15	1.25	1.35
Shim no.	0730 006 518	0730 006 519	0730 006 521	0730 006 522	0730 006 524
Shim/Crown wheel side Required disk thickness	1.35	1.25	1.15	1.05	0.95
Shim no.	0730 006 524	0730 006 522	0730 006 521	0730 006 519	0730 006 518

(16) Insert the determined shim (e.g. $s = 1.15$ mm) and the bearing outer ring into the hole of the axle housing on the differential carrier side.

※ Pivot axle housing 90°.

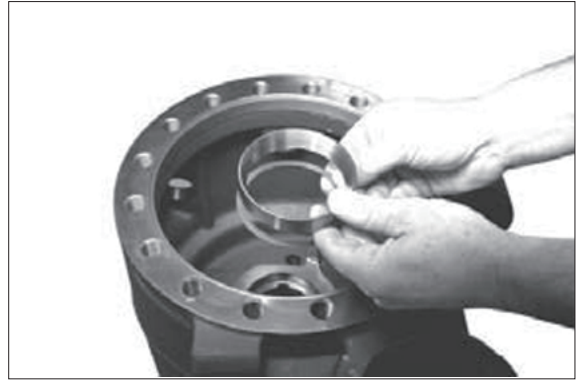

17W98FA091

(17) Insert the determined shim (e.g. $s = 1.15$ mm) and the bearing outer ring into the hole of the axle housing on the crown wheel side.

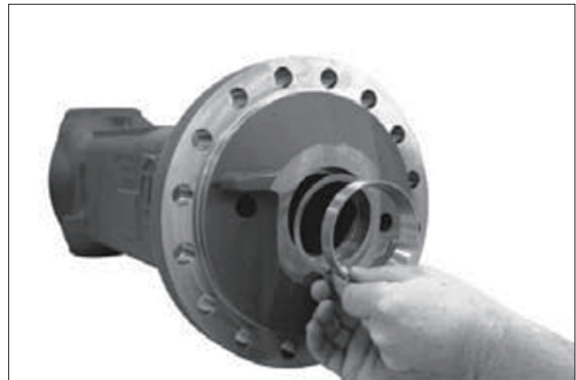

17W98FA092

(18) Check the contact pattern of the bevel gear set

Wet some drive and coast flanks of the crown wheel with marking ink.



17W98FA093

(19) Insert the preassembled differential into the axle drive housing.

(S) Internal extractor 5870 300 005



17W98FA094

(20) Use lifting tackle to mount the axle housing (crown wheel side) and preliminarily fix with hexagon screws.

Tightening torque (M18/10.9)
..... MA = 390 Nm

※ Preliminarily fix axle housing without O-ring.



17W98FA095

(21) Roll the crown wheel by rotation on the input flange several times in both directions over the input pinion.

Then remove axle housing again and lift differential out of the axle drive housing. Compare the obtained contact pattern with contact pattern example page 0/4 and 0/5.

※ In case of a contact pattern deviation a measuring mistake was made when determining the shim (figure FA080), which must be absolutely corrected.

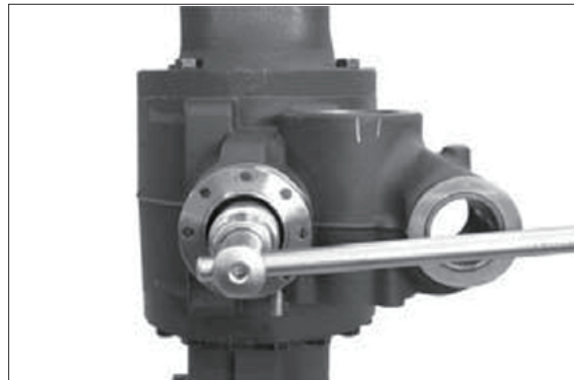

17W98FA096

(22) Grease O-ring (see arrow) and mount to axle housing.

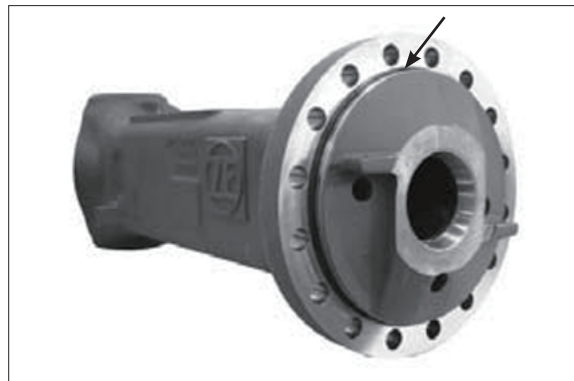

17W98FA097

(23) Use lifting tackle to mount the axle housing (part II), finally tighten with hexagon screws.

Tightening torque (M18/10.9)
..... MA = 390 Nm

Then bring axle into horizontal position and reassemble the second clamping angle (S) (see also figure FA001).



17W98FA098

(24) Mount shaft seal ring (input flange)

Loosen hexagon nut and pull the input flange from the input pinion.

(S) Clamping fork 5870 240 025

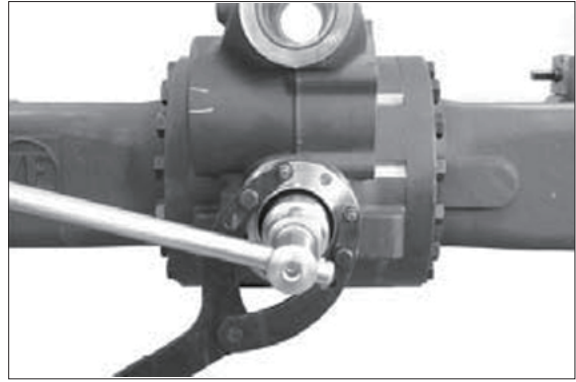

17W98FA099

(25) Comment on sketch:

- 1 = Input pinion
- 2 = Axle drive housing
- 3 = Tapered roller bearing
- 4 = Shaft seal ring
- 5 = Screen sheet
- 6 = Input flange
- 7 = Disk
- 8 = Hexagon nut
- X = Installation dimension → 13.5 +0, 2 mm

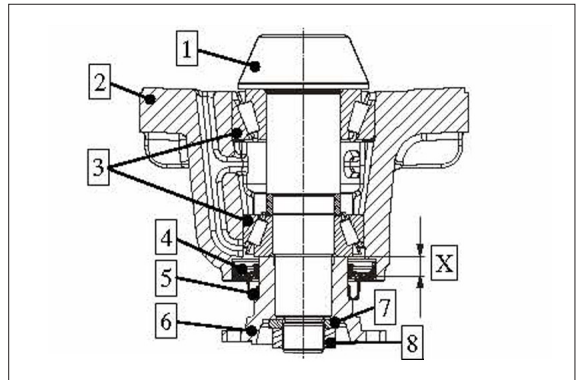

17W98FA100

(26) Mount shaft seal ring with the seal lip showing to the oil chamber.

(S) Driver tool 5870 048 286

- ※ Use of the specified driver tool (S) ensures the exact installation position of the shaft seal ring.
- ※ Just before fitting, wet contact face shaft seal ring/axle drive housing with lubricant. Apply grease on seal and dust lip of the shaft seal ring.

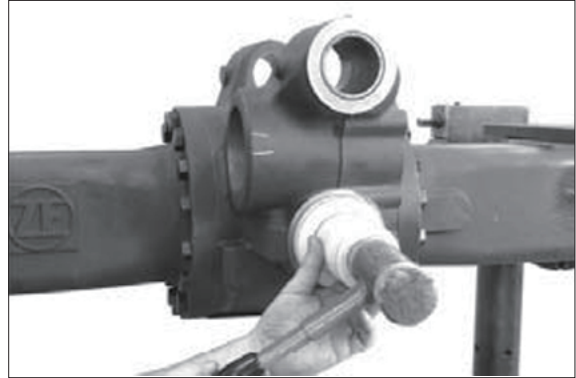

17W98FA101

(27) Mount input flange, finally tighten with disk and hexagon nut.

Tightening torque (M30x1.5)
..... MA = 600 Nm

(S) Clamping fork 5870 240 025

- ※ Wet thread of the hexagon nut with Loctite no. 262.



17W98FA102

3) OUTPUT

(1) Preassembly axle housing

Insert bushing into hole of axle housing considering installation dimension "B" and installation position "Y" (see also sketch FA104 and FA106).

(S) Driver tool 5870 055 090

(S) Handle 5870 260 002



17W98FA103

(2) Comment on sketch:

1 = Axle housing

2 = Bushing

B = Installation dimension 1.0 ± 0.3 mm

Y = Installation position / lubrication groove outlet of bushing (top view)

※ Lubrication groove outlet (V-point) must be mounted in 6 o'clock position (bottom) and showing to the oil chamber side.

※ Use of the specified driver tool (S) ensures the exact installation depth of the bushing.

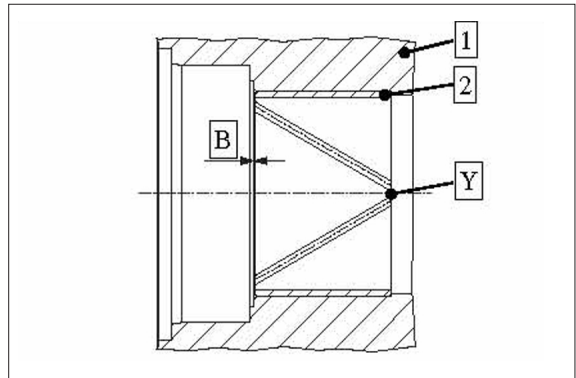

17W98FA104

(3) Flush-mount seal ring with the seal lip showing to the oil chamber (see sketch FA106) into the axle housing hole.

(S) Driver tool 5870 055 090

(S) Handle 5870 260 002

※ Use of the specified driver tool (S) ensures the exact installation position of the shaft seal ring.



17W98FA105

※ Just before fitting wet the contact face shaft seal ring/axle drive housing with lubricant.

Apply grease on seal and dust lip of the shaft seal ring.

(4) Comment on sketch:

1 = Axle housing

2 = Shaft seal ring

3 = Bushing

4 = Bearing outer rings (pivot bearing)

Y = Lubrication groove outlet (V-point – in 6 o'clock position and on oil chamber side)

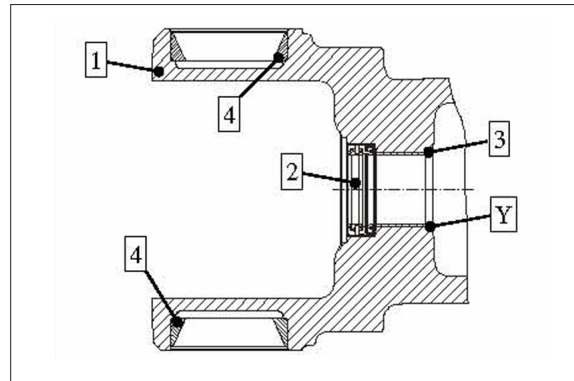

17W98FA106

(5) Insert both bearing outer rings into the pivot bearing holes of the axle housing.

(S) Driver tool 5870 058 022

(S) Handle 5870 260 002

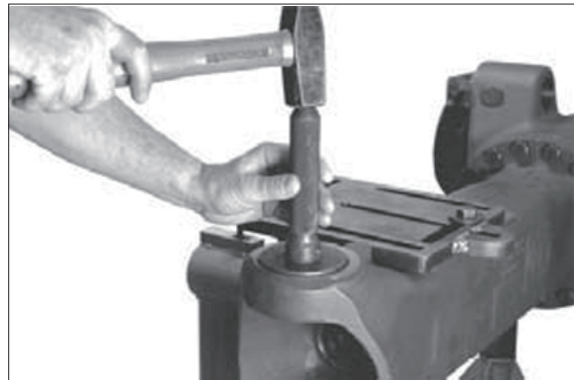

17W98FA107

(6) Install the u-joint shaft by inserting the u-joint shaft into the axle bevel gear teeth.

※ Pay attention to shaft seal ring in the axle housing risk of damage.

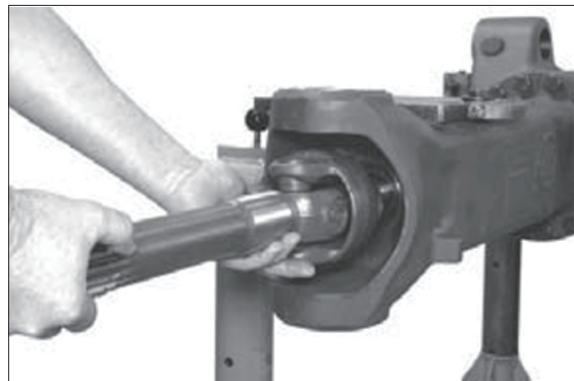

17W98FA108

(7) Knuckle housing (pivot bearing-SET-RIGHT)

Seal machining openings of oil supply holes – position 1 and 2 with plugs.

(S) Lever riveting tongs 5870 320 016

※ Operation is only required when using a new knuckle housing.

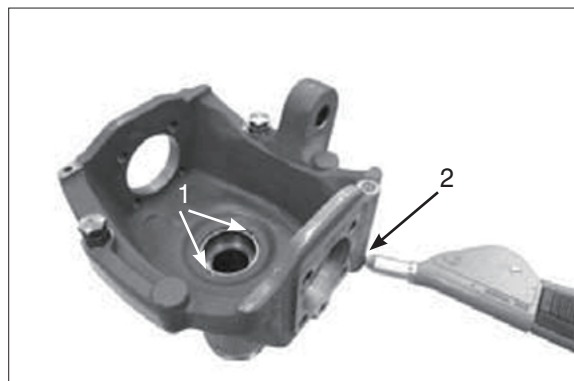

17W98FA109

- (8) Insert bushing into the hole of the knuckle housing considering the installation dimension "B" and installation position "Y" (see also sketch FA111 and FA113).

(S) Driver tool 5870 055 090
(S) Handle 5870 260 002



17W98FA110

- (9) Comment on sketch:

1 = Knuckle housing

2 = Bushing

B = Installation dimension . . . 2.0 ± 0.2 mm

Y = Installation position / lubrication groove outlet of the bushing

- ※ Lubrication groove outlet (V-point) must be mounted in 6 o'clock position (bottom) and showing to the oil chamber side (referred to the axle fitted into the vehicle).
- ※ Use of the specified driver tool (S) ensures the exact installation depth of the bushing.

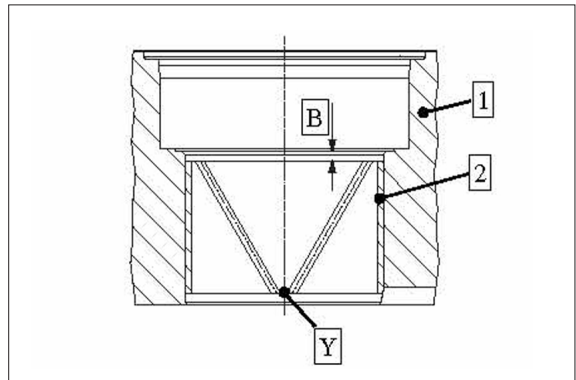

17W98FA111

- (10) Insert shaft seal ring into the hole of the knuckle housing with the seal lip showing to the oil chamber – considering the installation dimension "W" (see also sketch below).

(S) Driver tool 5870 055 090
(S) Handle 5870 260 002

- ※ Use of the specified driver tool (S) ensures the exact installation position of the shaft seal ring.



17W98FA112

(11) Comment on sketch:

1 = Knuckle housing

2 = Shaft seal ring

3 = Bushing

W = Installation dimension – shaft seal ring
..... 3.5 ± 0.2 mm

Y = Lubrication groove outlet (V-point)
must be mounted in 6 o'clock
position and showing to the oil
chamber side (referred to the axle
fitted into the vehicle)

※ Just before fitting wet contact face shaft
seal ring / knuckle housing with sealing
agent.

Apply grease on seal and dust lip of the
seal ring.

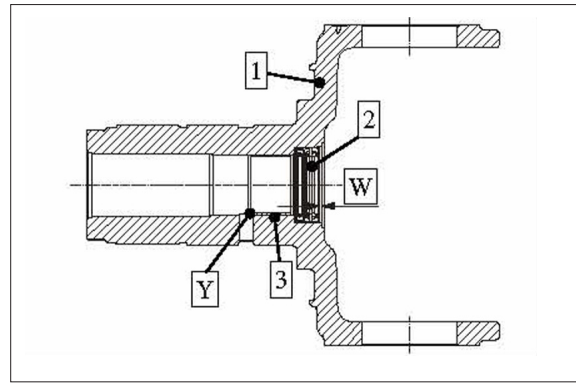

17W98FA113

(12) Grease O-ring (see arrow) and insert it
into the groove of the bearing pin.



17W98FA114

(13) Place sealing cap (see arrow) and mount
the tapered roller bearing until contact
position is obtained.



17W98FA115

(14) Locate pre-assembled knuckle housing on axle housing and carefully mount u-joint shaft.

(S) Eyebolts (M 18) 5870 204 085

※ Pay attention to shaft seal ring in the knuckle housing risk of danger.

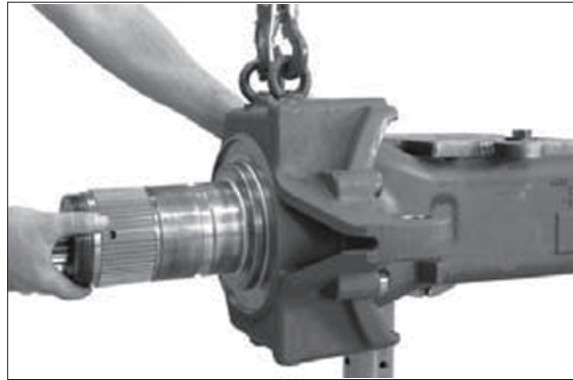

17W98FA116

(15) Insert the pre-assembled lower bearing pin and preliminarily fix with hexagon screws.

※ Pay attention to installation position mount bearing pin with lubrication nipple showing to axle centre.

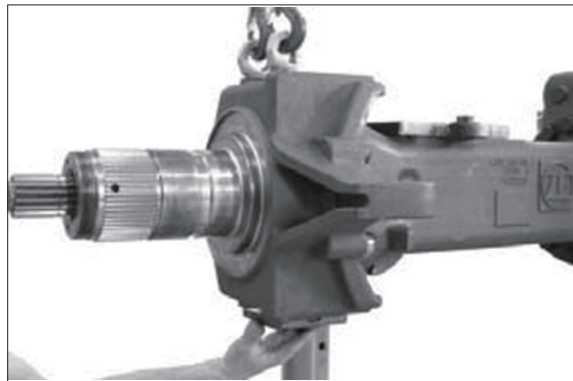

17W98FA117

(16) Insert O-ring (see arrow) or O-rings into countersink of the knuckle housing.

1 pcs for version with breather valve in the knuckle housing

2 pcs for version with breather valve in the bearing pin

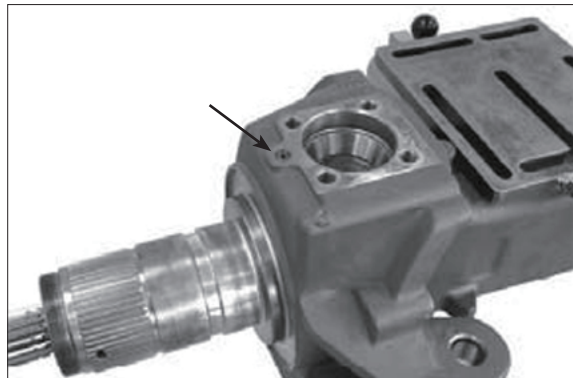

17W98FA118

(17) Insert pre-assembled upper bearing pin.

※ Observe installation position mount bearing pin with oil supply holes showing to axle centre.

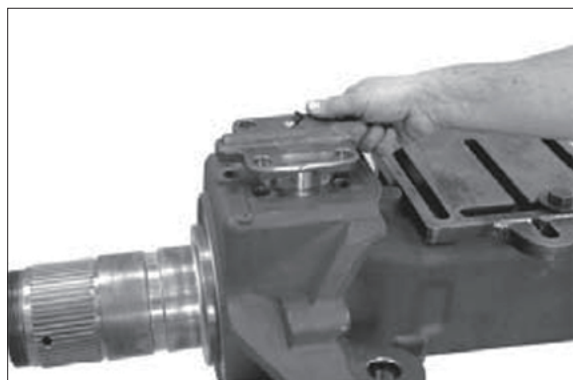

17W98FA119

(18) Fix both bearing pins definitely.

※ Tightening torque (M 18/10.9)
..... MA = 390 Nm

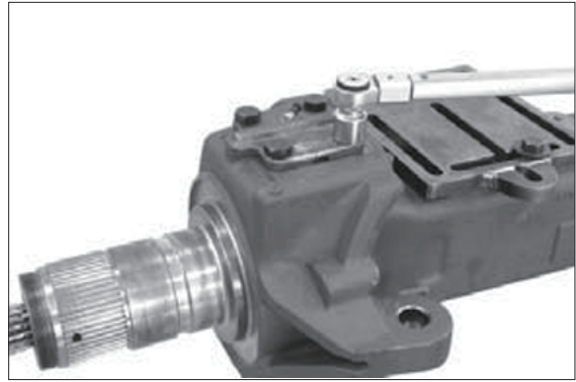

17W98FA120

(19) Mount lubrication nipple in both bearing pins (arrow 1 showing to the axle centre) and apply grease to the pivot bearing.

Tightening torque (M 10×1)
..... MA = 3 Nm

Mount breather valve (arrow 2, position depending on version : integrated in the knuckle housing or in the bearing lid) and provide with dust cap.

Tightening torque (M 14×1,5)
..... MA = 20Nm

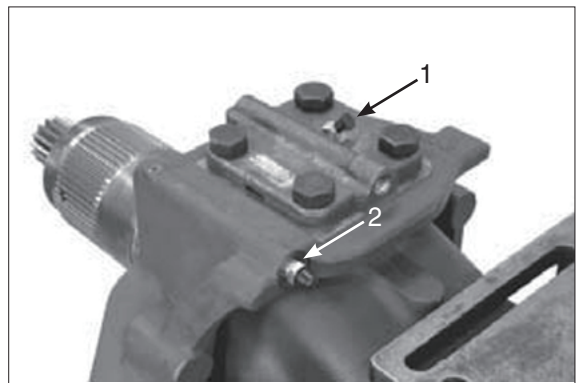

17W98FA121

4) HUB (Hub bearing-SET-RIGHT)

- (1) Insert both bearing outer rings (1) of the hub bearing until contact position is obtained.

Press wheel bolts (2) into the hub until contact position is obtained.

Oil O-ring (3) and locate in annular groove of hub.

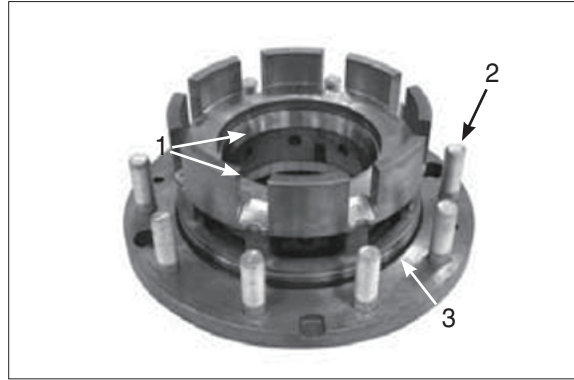

17W98FA122

- (2) Press shaft seal ring with the marking "OUT SIDE" showing outside (upwards) into the hub.

(S) Driver tool 5870 051 035

- ※ Use of the specified driver tool (S) ensures the exact installation position of the shaft seal ring.
- ※ Wet the outer diameter of the shaft seal ring with Loctite no. 574.



17W98FA123

- (3) Comment on sketch:

1 = Hub
2 = Shaft seal ring
X = Installation dimension – Shaft seal ring
..... 0.0~0.3 mm

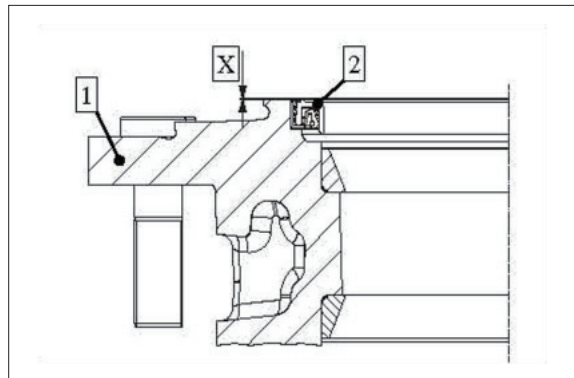

17W98FA124

- (4) Heat the tapered roller bearing and mount until contact position with the knuckle housing is obtained.

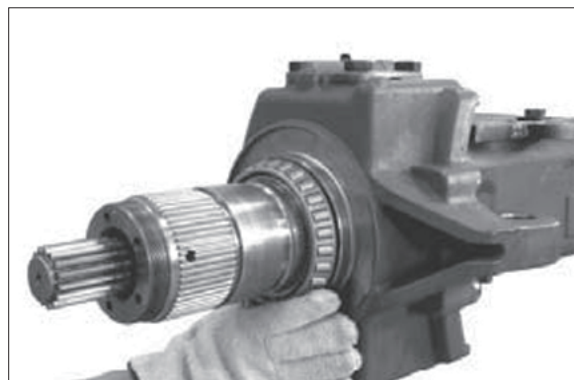

17W98FA125

(5) Insert spacer bushing.

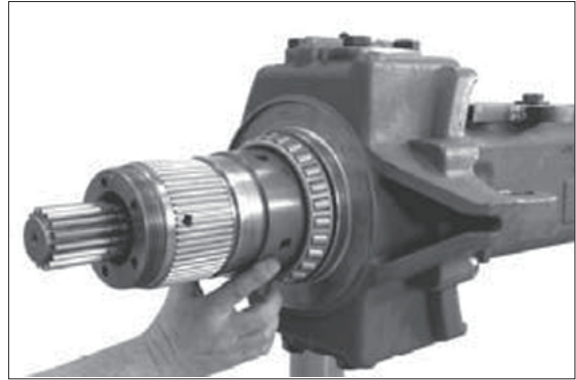

17W98FA126

(6) Install preassembled hub until contact is obtained and fix with heated tapered roller bearing.

(S) Lifting bracket 5870 281 043

※ Just before fitting wet the seal lips of the shaft seal ring with lubricant.



17W98FA127

(7) Oil O-ring and insert it into the annular groove (see arrow) of the knuckle housing.

Then install disk carrier.

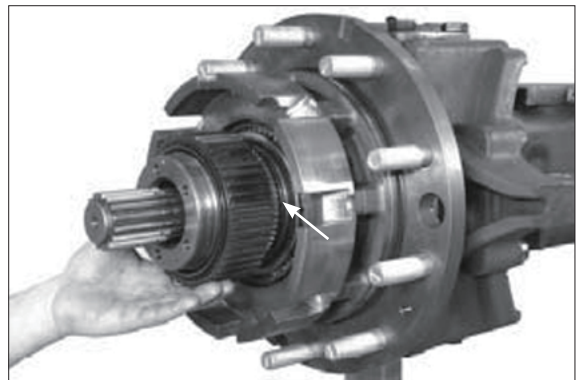

17W98FA128

(8) Bring disk carrier and hub bearing into contact position (figure FA129 and FA130)

Install ring gear (without sealing elements).

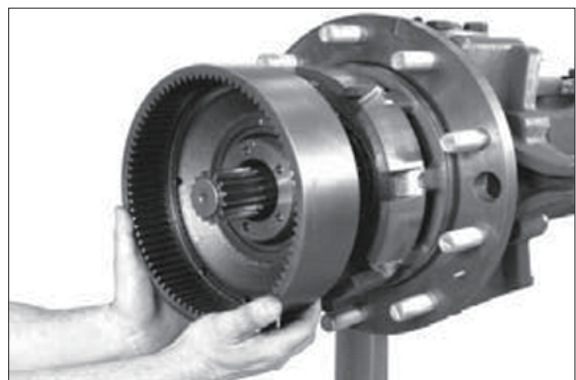

17W98FA129

- (9) Bring hub bearing into contact position for this purpose tighten slotted nut with a tightening torque of max. 1400 Nm.

(S) Socket wrench 5870 656 097

- ※ While tightening the slotted nut rotate hub in both directions several times roller setting.
- ※ Apply lubricant to thread knuckle housing / slotted nut.



17W98FA130

- (10) Loosen slotted nut again and remove ring gear.

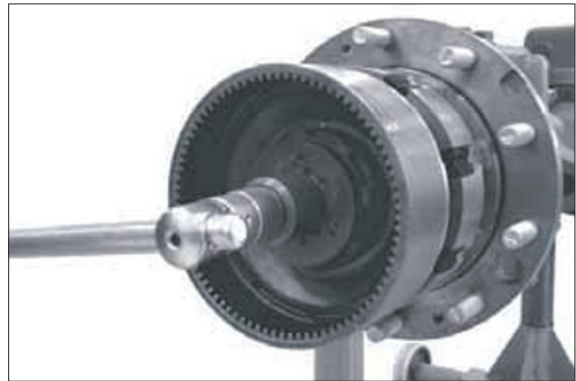

17W98FA131

5) DISK BRAKE

- (1) Install disk package alternately starting with an outer disk.

- ※ Take the actually required disk fitting / arrangement from the corresponding spare parts list.
- ※ Bring inner clutch disks in a position where one of the tooth recesses (see arrow) is in 6 o'clock position with axle being installed in the vehicle.



17W98FA132

- (2) Oil O-ring and locate in annular groove of disk carrier.



17W98FA133

(3) Oil U- and support rings and insert them into the annular grooves of the ring gear.

※ Observe installation position, see sketch below.



17W98FA134

(4) Comment on sketch:

- 1 = Ring gear
- 2 = Support ring
- 3 = U-ring
- 4 = U-ring
- 5 = Support ring

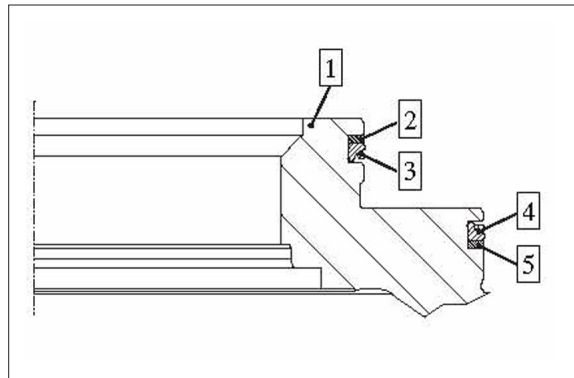

17W98FA135

(5) Mount cylindrical pins into piston, considering installation dimension "X".

X = Installation dimension 16.00 mm

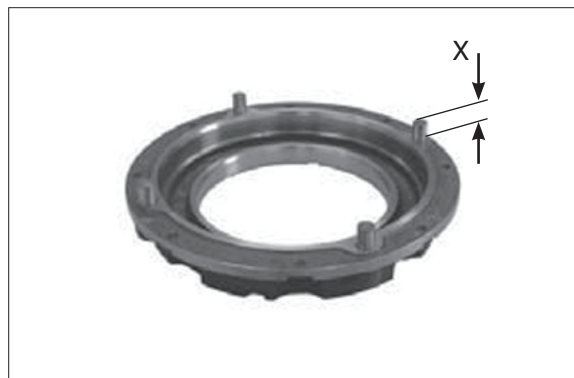

17W98FA136

(6) Install piston on ring gear.



17W98FA137

- (7) Fix piston with "new" hexagon screws (1), spring sleeves (2) and compression springs (3 and 4).

Tightening torque (M 6/8.8)
 MA = 8 Nm

※ Use hexagon screws just once.



17W98FA138

- (8) Comment on sketch:

1 = Hexagon screw (special version)

2 = Spring sleeve

3 = Compression spring

4 = Compression spring

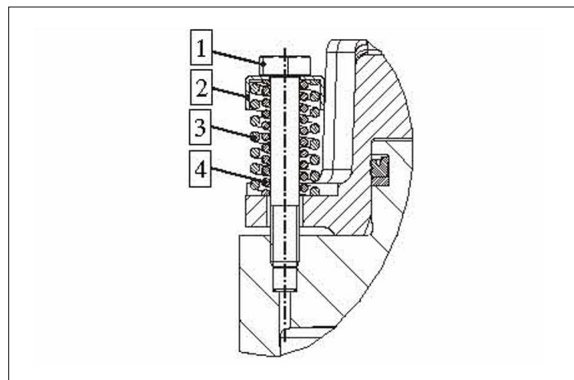

17W98FA139

- (9) Mount preassembled ring gear considering the installation position (markings O in 12 o'clock position - see arrows).

※ Ensure exact tooting position of oil supply holes knuckle housing / ring gear (pressure oil supply to brake piston).

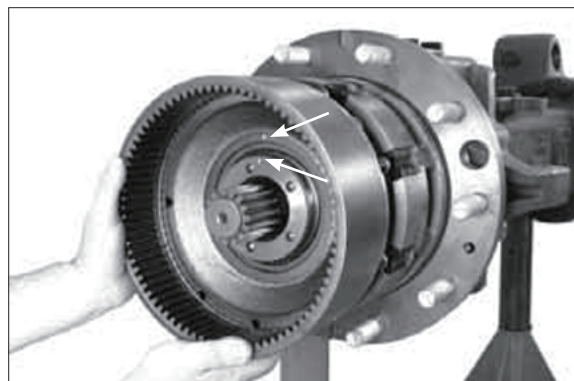

17W98FA140

- (10) Oil O-ring and insert in recess (see arrow).



17W98FA141

(11) Fix ring gear with slotted nut.

Tightening torque:

(M 110 x 1.5) MA = 1400 + 600 Nm

(S) Socket wrench 5870 656 097

- ※ First tighten slotted nut with 1400 Nm, then retighten slotted nut until a fixing hole overlaps a threaded hole in the knuckle housing.

While tightening the slotted nut rotate hub in both directions several times roller setting.

- ※ Wet thread knuckle housing / slotted nut with lubricant.



17W98FA142

(12) Make leakage test of multi-disk brake

Mount threaded coupling (S) and connect HP pump.

(S) HP pump 5870 287 007

(S) Threaded coupling (M14x1.5) 5870 950 102

(S) Breather bottle 5870 286 072

- ※ Breathe brake completely before starting the test.

Test media :

Motor oils SAE-10W

High-pressure test:

Build up test pressure $p = 100$ bar and close locking valve of HP pump.

A pressure drop by max. 3 bar is permissible during a 5-minute test duration.

Low pressure test:

Reduce test pressure $p = 5$ bar and close locking valve.

No pressure drop is allowed during a 5-minute testing duration.

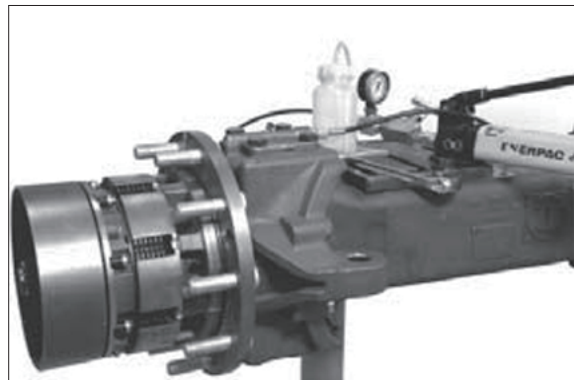

17W98FA143

(13) Adjust and check piston stroke

Piston stroke / disk clearance = 0.7 1.3 mm
 Build up braking pressure (100 bar) and close locking valve of the HP pump.

Determine dimension "A", from face of the ring gear (1) through measuring hole (see also sketch FA145) to the face of the piston (3).

Dimension "A" e.g. 83.10 mm

※ Breathe brake completely before starting the measuring operation.

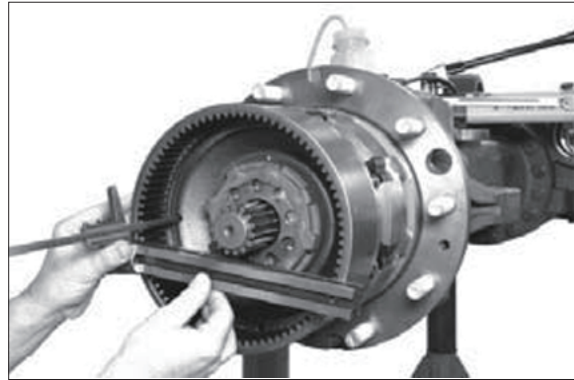

17W98FA144

(14) Then open locking valve of the HP pump and release pressure from brake (reset piston through compression springs).

Determine dimension "B", from the face of the ring gear (1) through the measuring hole (see also sketch FA146) to the face of the piston (3).

Dimension "B" e.g. 82.10 mm

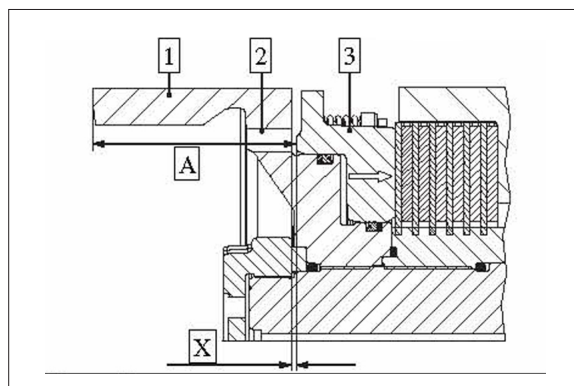

17W98FA145

(15) CALCULATION EXAMPLE:

Dimension "A" e.g. 83.10 mm

Dimension "B" e.g. - 82.10 mm

Difference = Piston stroke = 1.00 mm

※ If the required piston stroke (0.7 ... 1.3 mm) is not achieved, correct it with the corresponding inner clutch disk (s) – refer to corresponding spare parts list.

Then remove HP pump (S), breather bottle (S) and threaded coupling (S).

Comment on sketch 43 and 44:

1 = Ring gear

2 = Measuring hole

3 = Piston

X = Piston stroke / disk clearance

(S) Straightedge 5870 200 022

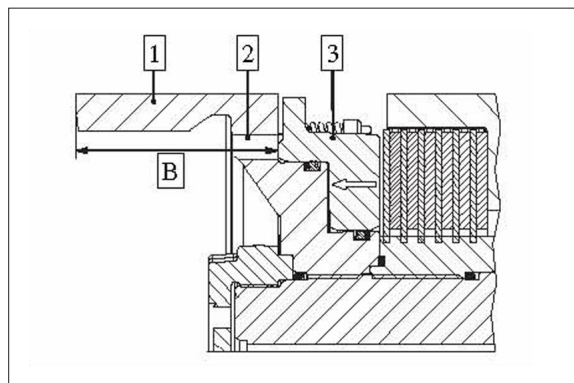

17W98FA146

(16) Secure slotted nut with cylindrical screw
(please also refer to figure FA142)

Tightening torque (M 10/8.8)
..... MA = 32 Nm



17W98FA147

(17) Insert thrust washer.

※ Observe installation position ensure that
both lugs of the thrust washer are
engaged each in a spare fixing hole of the
slotted nut.



17W98FA148

(18) Mount thrust washer with shoulder
showing to the retaining ring (outwards).



17W98FA149

(19) Fix thrust washers by using a retaining
ring.

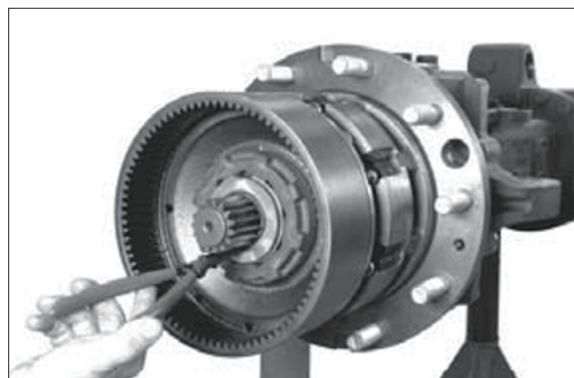

17W98FA150

6) PLANETARY CARRIER

- (1) Press thrust washer into the planetary carrier until contact position is obtained.

(S) Driver tool 5870 048 263

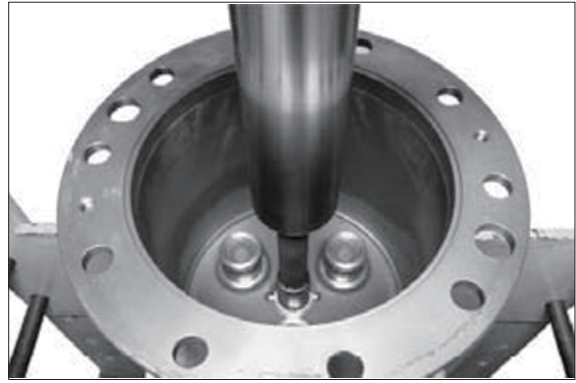

17W98FA151

- (2) Insert the cylindrical roller bearing into the planetary gear for this purpose press the cylindrical roller bearing through the packaging sleeve until the snap ring engages into the annular groove of the planetary gear.

※ Use packaging sleeve to facilitate assembly.

1 = Cylindrical roller bearing

2 = Packaging sleeve

3 = Snap ring

4 = Planetary gear

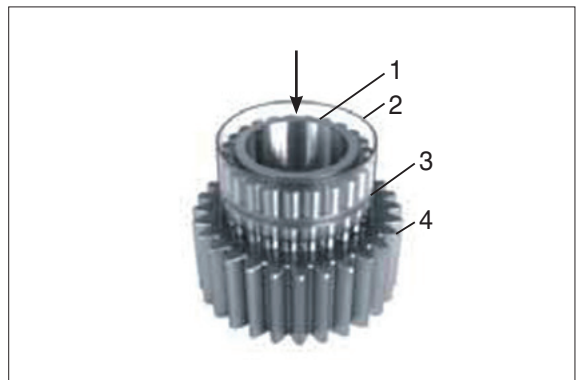

17W98FA152

- (3) Warm up bearing inner ring and install pre-assembled planetary gear until contact is obtained.

※ Mount bearing inner ring with large radius, showing to the planetary carrier (downwards).

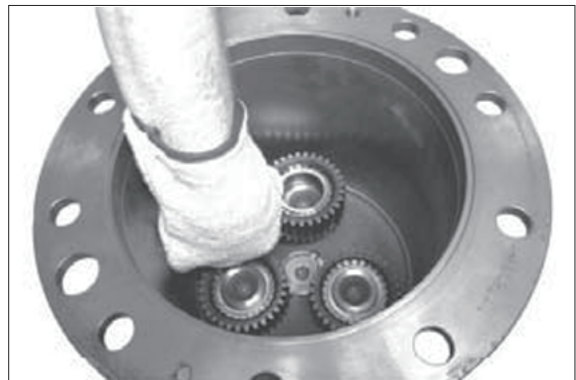

17W98FA153

- (4) Fix planetary gear by means of retaining ring.

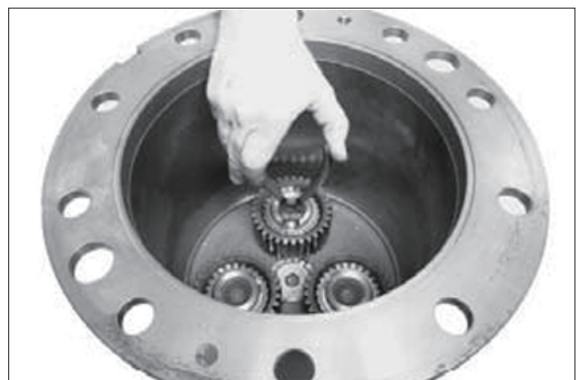

17W98FA154

- (5) Install preassembled planetary carrier and fix with hexagon screws.

Tightening torque (M12/8.8)
 MA = 55 Nm

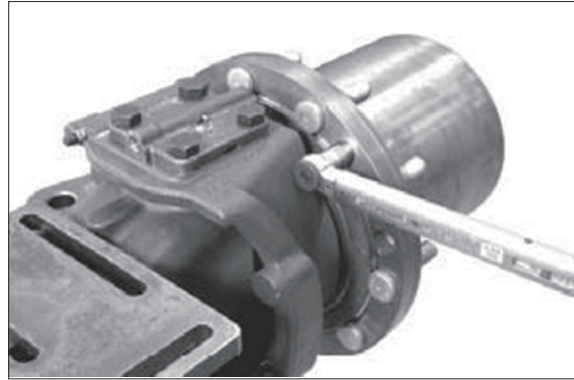

17W98FA155

(6) Output assy

Locate output assy on the axle by means of the lifting bracket (S) by installing the u-joint shaft in the axle bevel gear toothing.

(S) Lifting bracket 5870 281 043

- ※ Pay attention to shaft seal ring in the axle housing risk of damage.

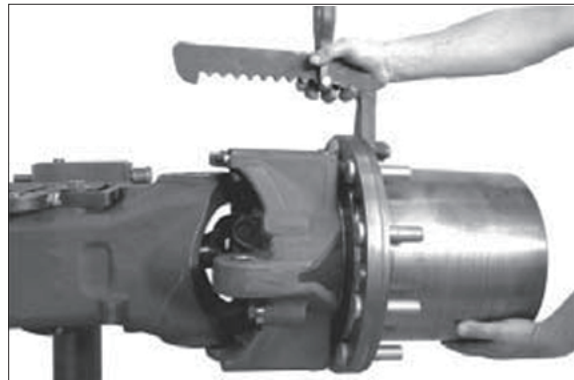

17W98FA156

- (7) Insert O-ring (see arrow) or O-rings into the countersink (s) of the knuckle housing.

1 pc for version with breather valve in knuckle housing.

2 pcs. for version with breather valve in bearing pin.

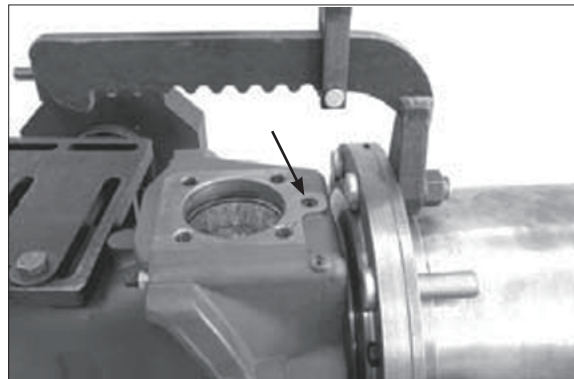

17W98FA157

- (8) Mount both bearing pins and fix with hexagon screws or locking screws.

Tightening torque (M 18/10.9)
 MA = 390 Nm

- ※ Observe installation position, mount upper bearing pin with oil supply holes showing to axle centre.

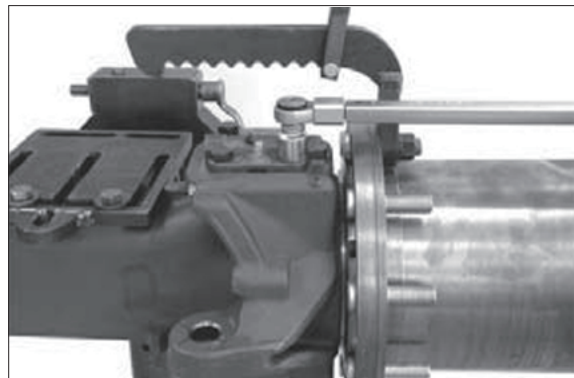

17W98FA158

(9) Pivot bearing

Super-cool bushings and insert into the heated pivot bearing hole until contact is obtained.

- ※ Observe installation position for bushing version with slot, insert bushings with slot in 12 o'clock position.
- ※ Prior to putting the axle into operation, fill in oil.

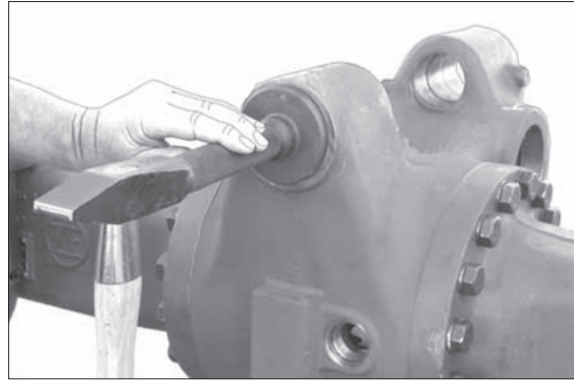

17W98FA159

7) STEERING

(1) Comment on sketch:

- 1 = Steering cylinder
 - 2 = Grooved ring
 - 3 = Scraper
 - 4 = Piston rod
 - 5a = O-ring
 - 5b = Form seal ring
 - 6 = Guide ring
 - 7 = Brake head
 - 8 = Dual ring
 - 9 = Retaining ring
 - 10 = O-Ring (only for version "with" O-ring)
 - 11 = Retaining ring
 - 12 = Flange
 - 13 = Retaining ring
 - 14 = Wrench point of attack (piston rod)
- } Piston sealing

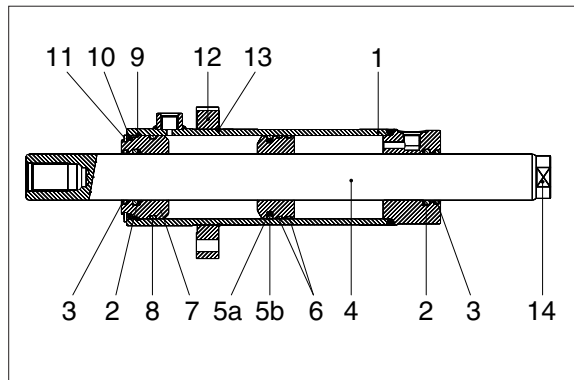

17W98FA160

(2) Preassemble steering

Mount U-ring (2) and scraper (3) in the steering cylinder (1).

- ※ Observe installation position – see detailed sketch.

Detailed sketch:

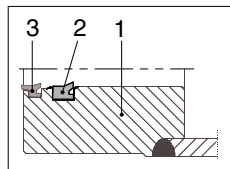

17W98FA161

- (3) Position inner installer (S1) on piston rod (4).

Mount O-ring (5a) and press with inner installer (S2) into annular groove (arrow) of the piston (4).

(S) Inner installer (S1) 5870 651 086

(S) Inner installer (S2) 5870 651 087

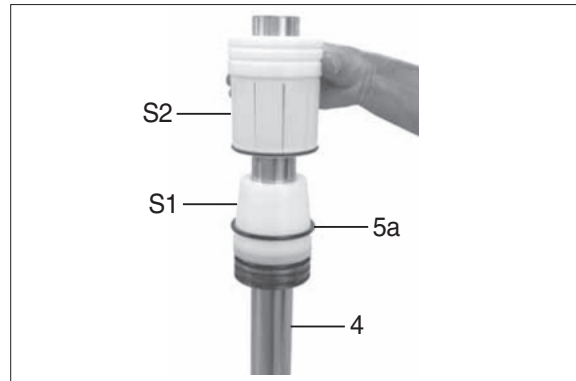

17W98FA162

- (4) Install form seal ring (5b) and press with inner installer (S2) into the annular groove of the piston (4).

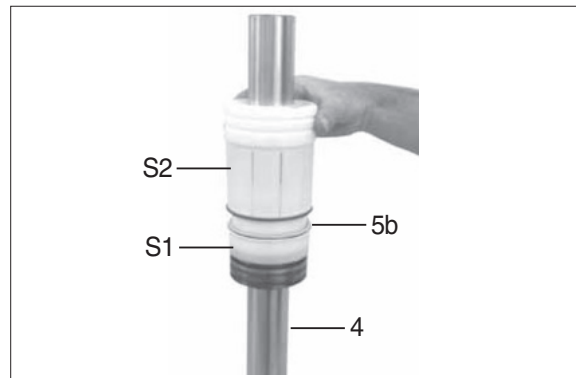

17W98FA163

- (5) Calibrate form seal ring (5b) with calibration bush (S3).

(S) Calibration bush (S3) 5870 651 090

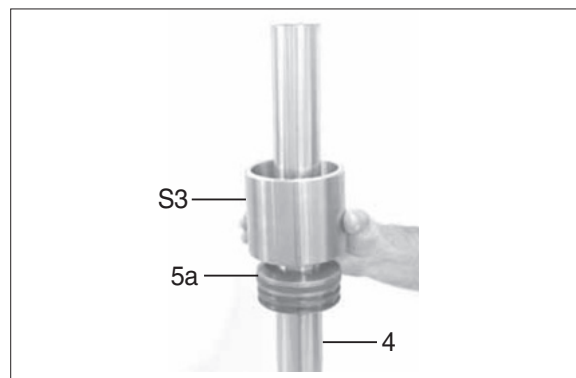

17W98FA164

- (6) Place both guide rings (6) into the annular grooves of the piston rod.

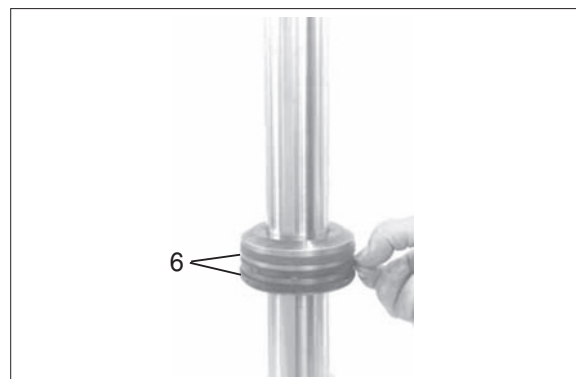

17W98FA165

(7) Insert preassembled piston rod into the steering cylinder.

- ※ Slightly oil all sealing elements before installing the piston rod.
- ※ Observe installation position, insert piston rod with wrench point of attack (14, see also sketch FA160) showing in direction of arrow.

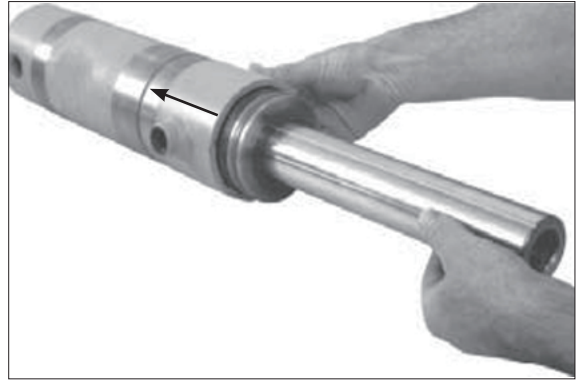

17W98FA166

(8) Insert U-ring (2), scraper (3) and dual ring (8) into the grooves of the brake head (7).

- ※ Observe installation position in this connection refer to detailed sketch.

Detailed sketch:

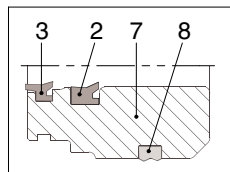

17W98FA167

(9) Push preassembled brake head into the steering cylinder so that the retaining ring (see figure FA169) can be mounted.

- ※ Slightly oil all sealing elements before inserting the brake head.



17W98FA168

(10) Engage retaining ring (9) into the groove of the cylinder tube.



17W98FA169

(11) Position the inserted brake head (7) on the snap ring (9) until contact is obtained (arrow).

Only for version with O-ring (see corresponding spare parts list) : Oil O-ring (10) and place into the recess.

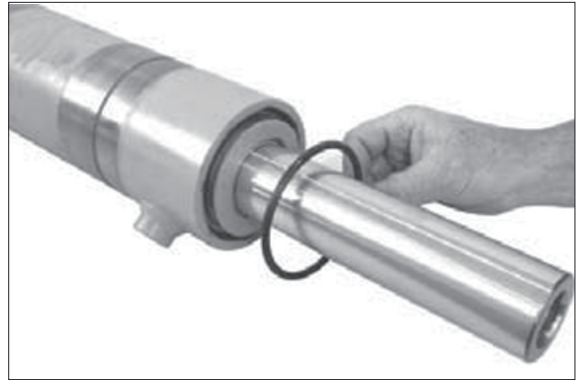

17W98FA170

(12) Fix brake head (7) with retaining ring (11).



17W98FA171

(13) Install flange (12) and engage retaining ring (13).

※ Observe installation position of flange mount flange with chamfer (see arrow) showing to the snap ring.

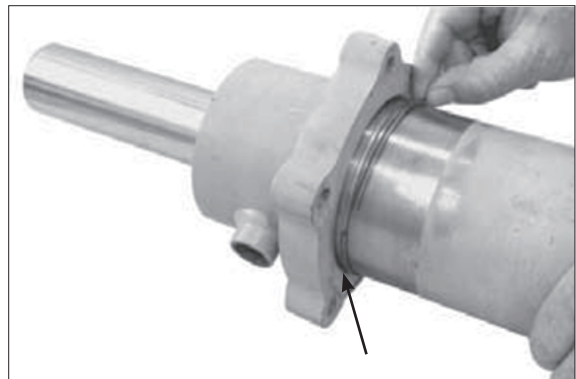

17W98FA172

(14) Mount steering

Apply anti-corrosive agent (Weicon Anti-Seize) on contact faces (cylinder tube / axle housing, see arrow).

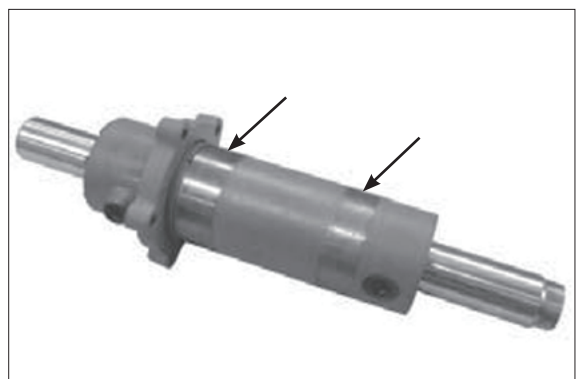

17W98FA173

(15) Insert preassembled steering cylinder into axle housing and fix with hexagon screws.

Tightening torque (M 12/8.8)
..... MA = 79 Nm

- ※ The radial installation position of the steering cylinder (position of the hydr. connections) is customer specific see also disassembly instructions figure FA018.
- ※ Wet the thread of the hexagon screws with Loctite no. 243.

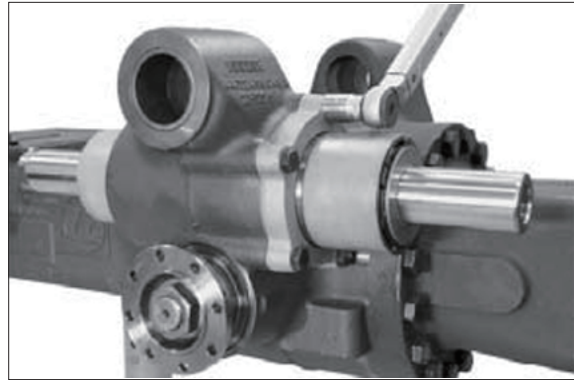

17W98FA174

(16) Bolt hexagon nut (2) and ball joint (3) to axial joint (1).

- ※ Do not tighten hexagon nut before setting the track.

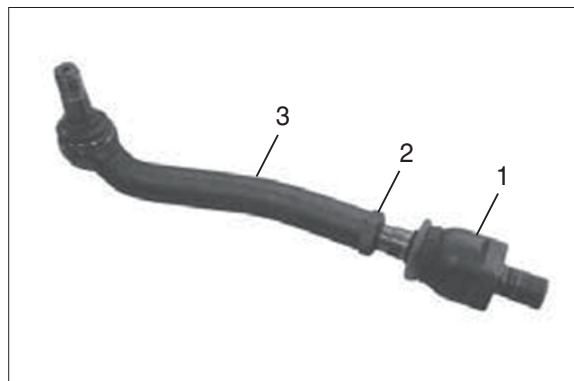

17W98FA175

(17) Fix both tie rods to piston rod (with offset showing to the axle housing).

Tightening torque (M30 × 1.5)
..... MA = 450 Nm

(S) Socket wrench (SW 55) 5870 656 100

- ※ Wet thread of the axial joint with Loctite no. 243.

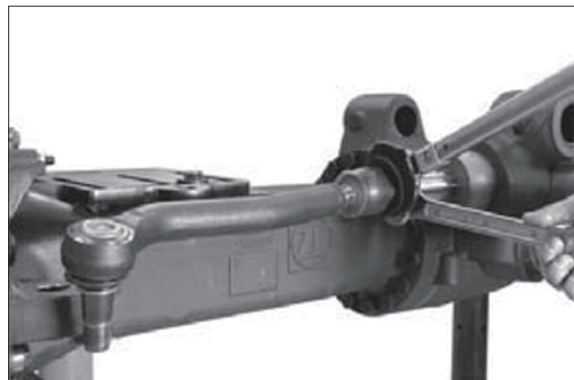

17W98FA176

(18) Install tie rod into knuckle housing and fix with "new" locking nut.

Tightening torque (M 27 × 1.5)
..... MA = 600 Nm

- ※ Use locking screws just once.

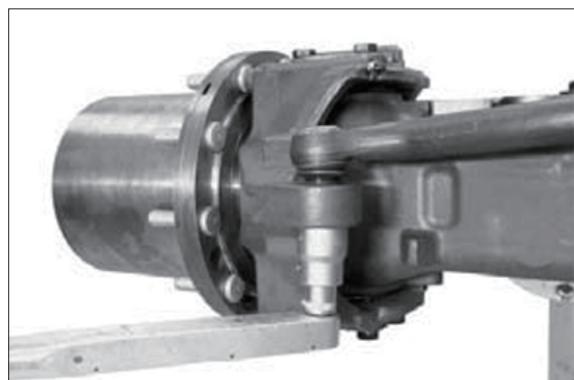

17W98FA177

(19) Steering setting and checking

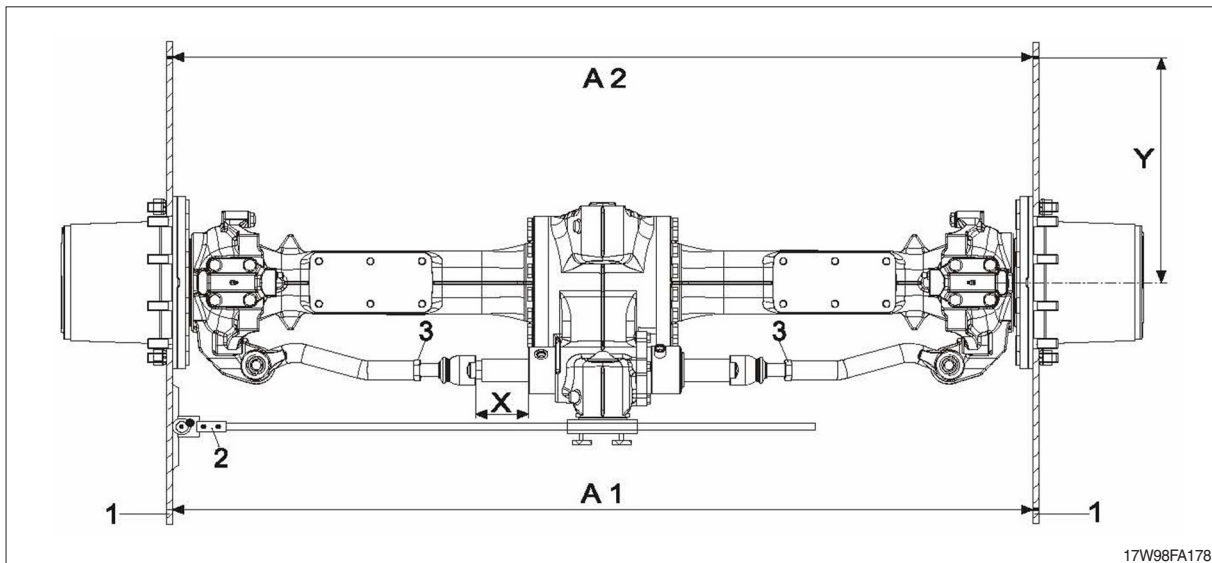

1 = (S) Straightedge 5870 200 029

2 = (S) Measuring device 5870 200 033

3 = Hexagon nut

X = Installation dimension (central position – piston rod)

Y = Distance – wheel center to rim flange

(20) Basic track setting

Bring piston rod in central position.

Dimension X = 119 mm (measured from front face/steering cylinder to contact face/axial joint).

※ Do not change axial position of piston rod any more during track setting.

Mount straightedge (1) in horizontal and central axis position.

Fix measuring device (2) to yoke.

Loosen hexagon nut (3) and set length of tie rod (axial joint) until the measuring device (2) indicates 0° (corresponds to a track setting of zero mm).

※ For a toe-in and toe-out setting, which might be required, stick to the vehicle manufacturer's specification.

※ Make setting on both output sides.

Check track setting (0°):

Determine dimension A1.

Rotate both outputs by 180° – dimension A2 must equal dimension A1.

Dimension "Y" = distance between rim center and rim flange.

Then fix both tie rods (axial joint) by means of hexagon nut (3).

Tightening torque (M28 × 1.5) MA = 390 - 410 Nm

(21) Steering angle setting

- ※ When track setting is required, steering angle setting may only be carried out after track setting has been completed.

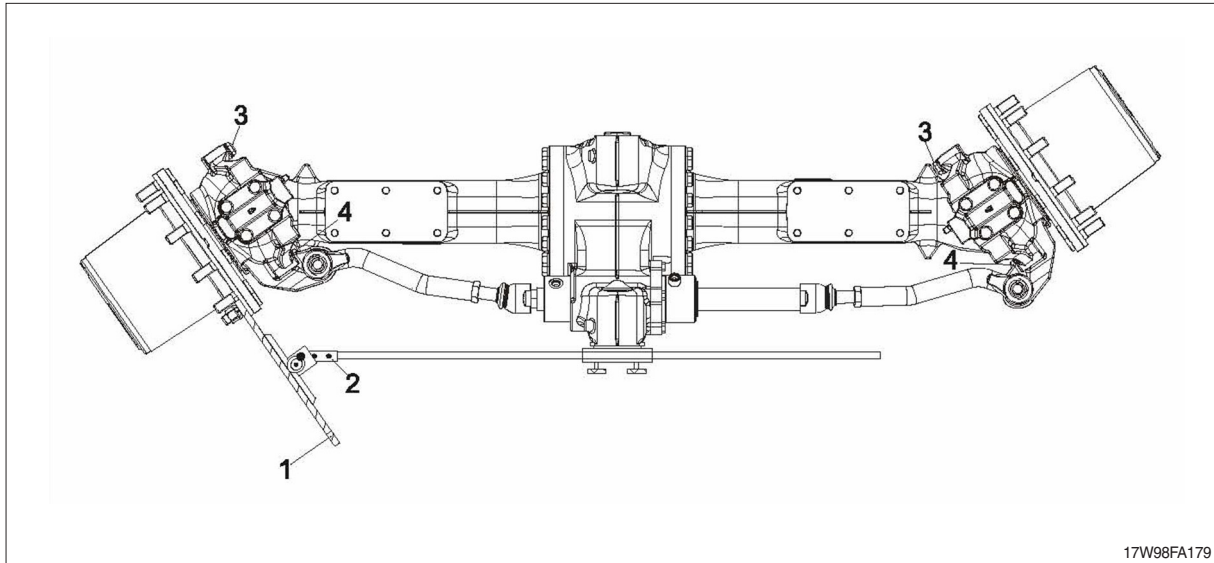

- 1 = (S) Straightedge 5870 200 029
- 2 = (S) Measuring device 5870 200 033
- 3 = Stop screw with stop washer (optional)
- 4 = Stop screw with hexagon nut

Mount straightedge (1) in horizontal and central axis position.

Fix measuring device (2) to yoke.

Pivot output until the required steering angle (e.g. 35°) is indicated on the measuring device (2).

- ※ Take the value of the steering angle to be set from the vehicle manufacturer's specifications.

Bring the stop screw (4) on the axle housing in contact position and lock with hexagon nut.

Tightening torque (M18/10.9) MA = 300 Nm

Then set inner stop by means of stop screw (3) and stop washer (s = optional).

Tightening torque (M18/10) MA = 390 Nm

- ※ Make setting on both output sides.

(22) Check leakage of steering

Make leakage test of steering in both steering directions by means of HP pump.

Test pressure: 200 bar

Test medium: Engine oils SAE 10W

Test pressure p = Build up 200 bar (bleed pressure chamber).

Then close connection to HP pump by means of locking valve.

A 5 bar pressure drop is permissible during a test duration of 20 sec.

(S) HP pump 5870 287 007

(S) Reduction 5870 950 161

(S) Clutch 0501 207 939

※ Prior to putting the axle into operation fill it with oil.

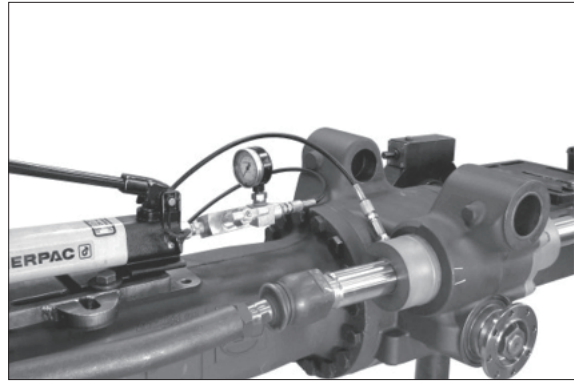

17W98FA180