

GROUP 7 TRANSMISSION

1. REMOVAL AND INSTALL

1) REMOVAL

- (1) Swing the work equipment 90° and lower it completely to the ground.
- (2) Operate the control levers and pedals several times to release the remaining pressure in the hydraulic piping.
- (3) Loosen the breather slowly to release the pressure inside the hydraulic tank.

▲ Escaping fluid under pressure can penetrate the skin causing serious injury.

※ When pipes and hoses are disconnected, the oil inside the piping will flow out, so catch it in oil pan.

- (4) Remove the transmission guard plate mounting bolt (1).
- (5) Remove the propeller shaft mounting nuts (2).
 - Tightening torque : $5.9 \pm 0.6 \text{ kgf} \cdot \text{m}$
($42.7 \pm 4.3 \text{ lbf} \cdot \text{ft}$)
- (6) Remove the travel motor mounting bolt (3).
 - Tightening torque : $29.7 \pm 4.5 \text{ kgf} \cdot \text{m}$
($215 \pm 32.5 \text{ lbf} \cdot \text{ft}$)
- (7) Remove the hoses (4).
Fit blind plugs to the disconnected hoses.
- (8) Remove the mounting bolts (5), then remove the transmission device assembly.
 - Weight : 140 kg (310 lb)
 - Tightening torque : $58.4 \pm 6.4 \text{ kgf} \cdot \text{m}$
($422 \pm 46.3 \text{ lbf} \cdot \text{ft}$)

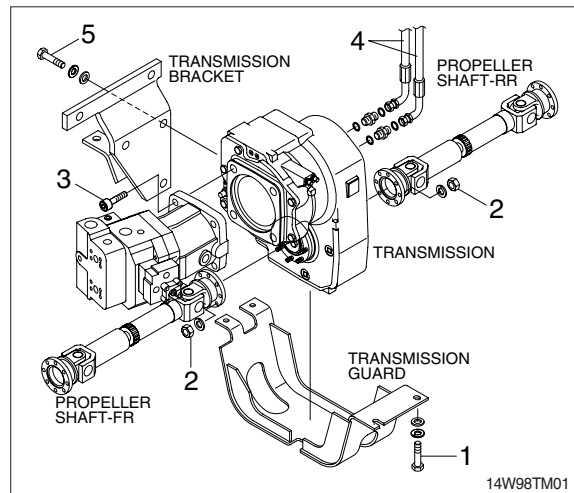

2) INSTALL

- (1) Carry out installation in the reverse order to removal.
- (2) Bleed the air from the transmission.
 - ① Remove the air vent plug.
 - ② Pour in hydraulic oil until it overflows from the port.
 - ③ Tighten plug lightly.
 - ④ Start the engine, run at low idling, and check oil come out from plug.
 - ⑤ Tighten plug fully.
- (3) Confirm the hydraulic oil level and check the hydraulic oil leak or not.

GROUP 7 TRANSMISSION

1. REMOVAL AND INSTALL

1) REMOVAL

- (1) Swing the work equipment 90° and lower it completely to the ground.
- (2) Operate the control levers and pedals several times to release the remaining pressure in the hydraulic piping.
- (3) Loosen the breather slowly to release the pressure inside the hydraulic tank.

▲ Escaping fluid under pressure can penetrate the skin causing serious injury.

※ When pipes and hoses are disconnected, the oil inside the piping will flow out, so catch it in oil pan.

- (4) Remove the transmission guard plate mounting bolt (1).
- (5) Remove the propeller shaft mounting nuts (2).
 - Tightening torque : $5.9 \pm 0.6 \text{ kgf} \cdot \text{m}$
($42.7 \pm 4.3 \text{ lbf} \cdot \text{ft}$)
- (6) Remove the travel motor mounting bolt (3).
 - Tightening torque : $29.6 \pm 3.2 \text{ kgf} \cdot \text{m}$
($214 \pm 23.1 \text{ lbf} \cdot \text{ft}$)
- (7) Remove the hoses (4).
Fit blind plugs to the disconnected hoses.
- (8) Remove the mounting bolts (5), then remove the transmission device assembly.
 - Weight : 140 kg (310 lb)
 - Tightening torque : $39 \pm 4.2 \text{ kgf} \cdot \text{m}$
($282 \pm 30.4 \text{ lbf} \cdot \text{ft}$)

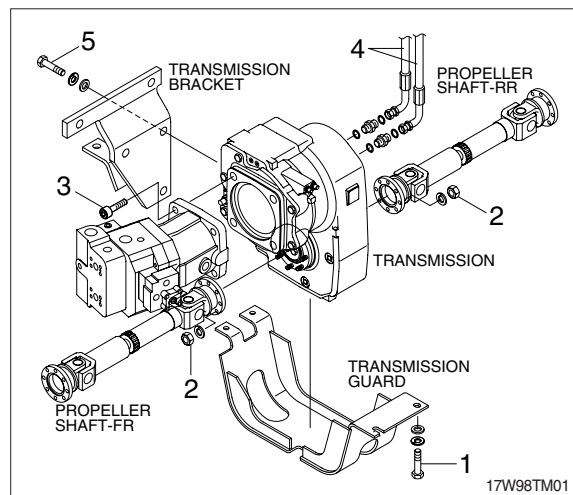

2) INSTALL

- (1) Carry out installation in the reverse order to removal.
- (2) Bleed the air from the transmission.
 - ① Remove the air vent plug.
 - ② Pour in hydraulic oil until it overflows from the port.
 - ③ Tighten plug lightly.
 - ④ Start the engine, run at low idling, and check oil come out from plug.
 - ⑤ Tighten plug fully.
- (3) Confirm the hydraulic oil level and check the hydraulic oil leak or not.

2. GENERAL INSTRUCTIONS

1) GENERAL WORKING INSTRUCTIONS

- (1) This manual has been developed for the skilled serviceman, trained by manufacturer.
- (2) During all operations, pay attention to cleanliness and skilled working.
Therefore, transmission removed from the machine must be cleaned prior to open them.
- (3) We assume that the special tools, specified by manufacturer, will be used.
The special tools are available from manufacturer.
- (4) After the disassembly, all components must be cleaned, especially corners, cavities and recesses of housing and covers.
- (5) The old sealing compound must be carefully removed.
- (6) Check lubricating holes, grooves and pipes for free passage. They must be free of residues, foreign material or protective compounds.
- (7) The latter refers especially to new parts.
- (8) Parts which have been inevitably damaged in a disassembly operation, must be generally replaced by new ones, e.g. rotary seal rings, O-rings, U-section rings, cap boots, protective caps etc..
- (9) Components such as roller bearings, thrust washers, synchronizing parts etc. which are subject to normal wear in automotive operation, must be checked by the skilled Serviceman.
He will decide if the parts can be reused.
- (10) For the heating of bearings etc., hot plates, rod heaters or heating furnaces must be used.
- (11) Never heat parts directly with the flame. An auxiliary solution would be to immerse the bearing in a vessel filled with oil, which is then heated with the flame.
In this way, damage to the bearings could be avoided.
- (12) Ball bearings, covers, flanges and parts like that must be heated to about 90 to 100°C.
- (13) Hot-mounted parts must be reset after cooling in order to assure a proper contact.
- (14) Before pressing shafts, bearings etc. in position, both parts must be lubricated.
- (15) During to reassembly, all specified adjustment values, testing specifications and tightening torque must be respected.
- (16) After the repair, units are filled up with oil.
- (17) After the oil filling, the oil level plugs and oil drain plugs must be tightened to the specified tightening torque.

2) IMPORTANT INSTRUCTIONS CONCERNING THE LABOUR SAFETY

- (1) In principle, repairers are themselves responsible for the labour safety.
- (2) The observance of all valid safety regulations and legal rules is a precondition to prevent damage to individuals and products during the maintenance and repair operations.
- (3) Before starting the work, the repairers have to make themselves familiar with these regulations.
- (4) The proper repair of these products requires especially trained personnel.
- (5) The repairer himself is obliged to provide for the training.

3. DISASSEMBLY AND REASSEMBLY

1) REMOVE BRAKE/CLUTCH/PLANET CARRIER

- (1) Loosen the screw plug and drain the oil use a suitable collector.

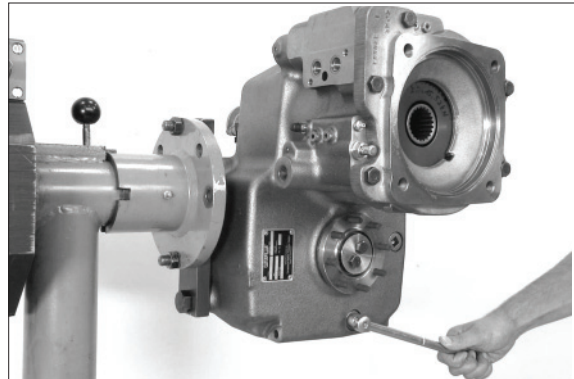

14W7A8TM002

- (2) Remove the lube oil pump or the downshift interlock.

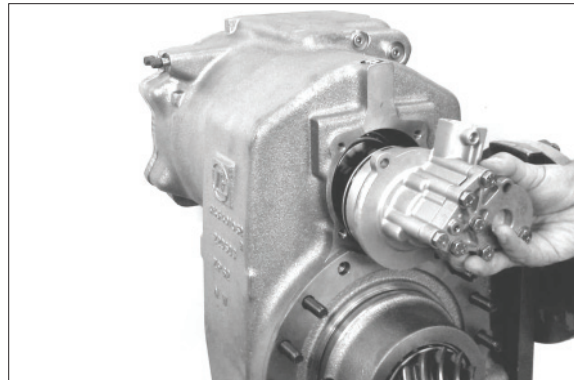

14W7A8TM003

- (3) Loosen the screw and pull off the speed transmitter.

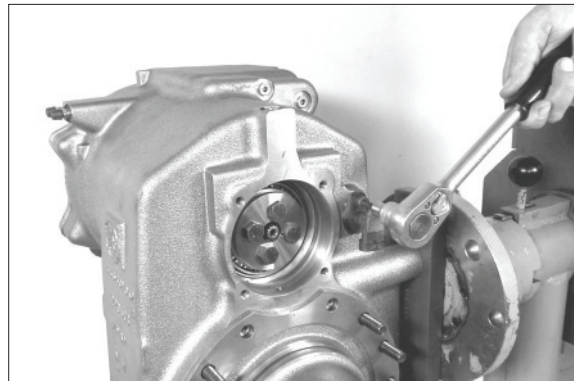

14W7A8TM004

- (4) Remove the bleeder.

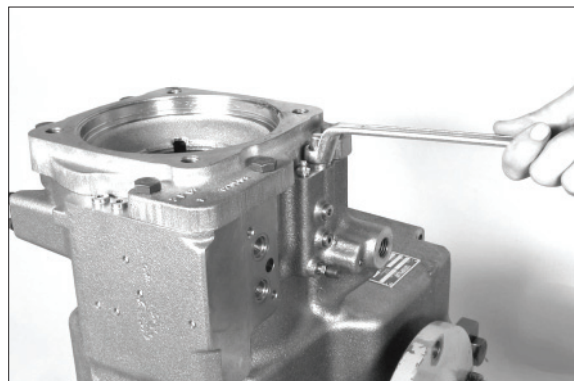

14W7A8TM005

- (5) Remove the compression spring and the ball.

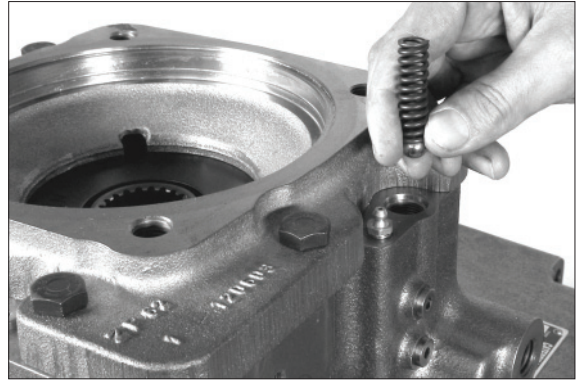

14W7A8TM006

- (6) Remove the threaded element (see detail X) with O-ring from the bore.

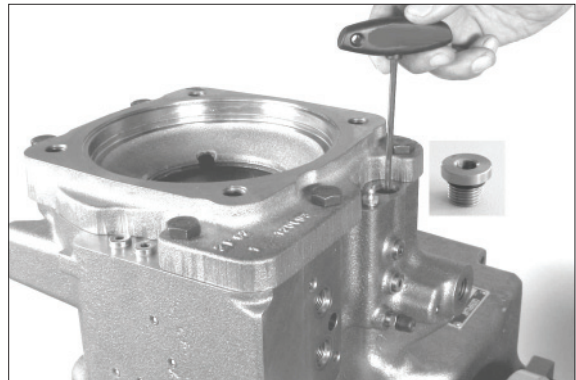

14W7A8TM007

- (7) Remove the lubrication nipple, both screw plugs and the bleeder valve- see arrow.

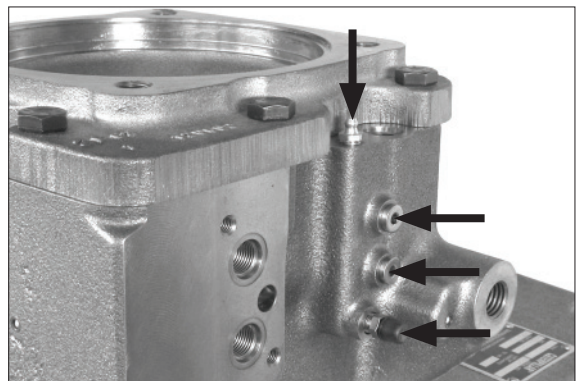

14W7A8TM008

- (8) Loosen the bolt connection of the input housing equally- the input housing is subject to a cup spring and compression spring preload !



14W7A8TM009

- (9) Take off the input housing and remove the O-ring (arrow).

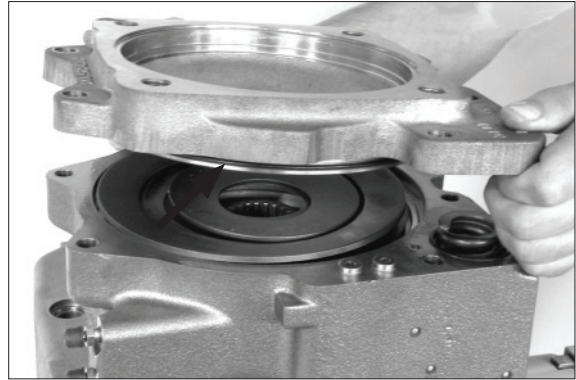

14W7A8TM010

- (10) Modulation valve :
Remove the compression spring and the O-ring (arrow).

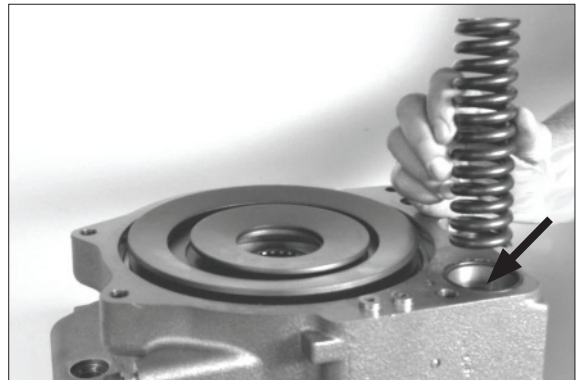

14W7A8TM011

- (11) Pull the complete piston out of the bore.
(S) Set of external pliers 5870 900 015

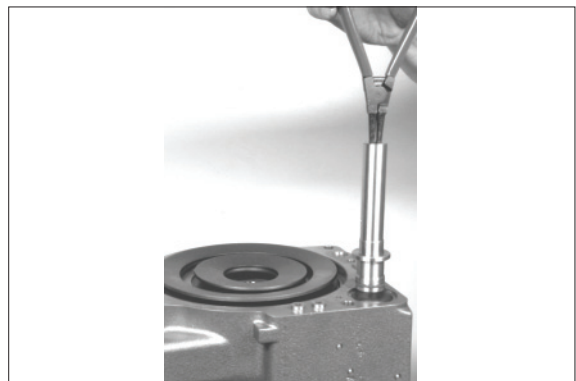

14W7A8TM012

- (12) Remove the cup springs from the brake.



14W7A8TM013

(13) Remove the cup springs from the clutch.

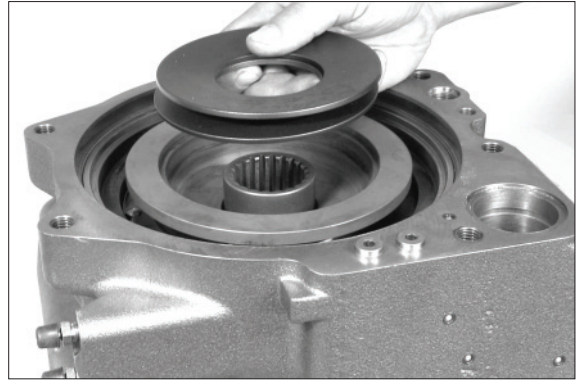

14W7A8TM014

(14) Remove the piston.

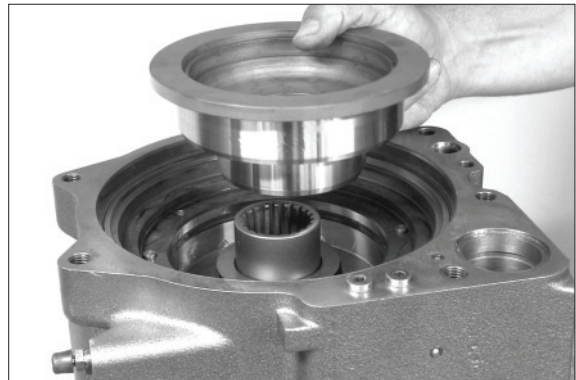

14W7A8TM015

(15) Pull off both cylinder pins (arrows).



14W7A8TM016

(16) Attach two eyebolts and pull the piston cautiously out of the housing - risk of damage!

(S) Eyebolts assortment 5870 204 002

(S) Lifting chain 5870 221 047

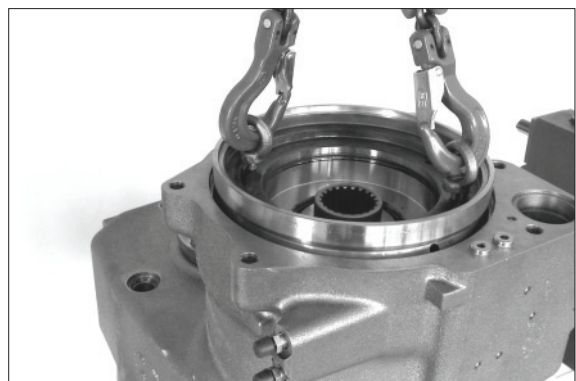

14W7A8TM017

(17) Remove both seals (arrows) from the piston.

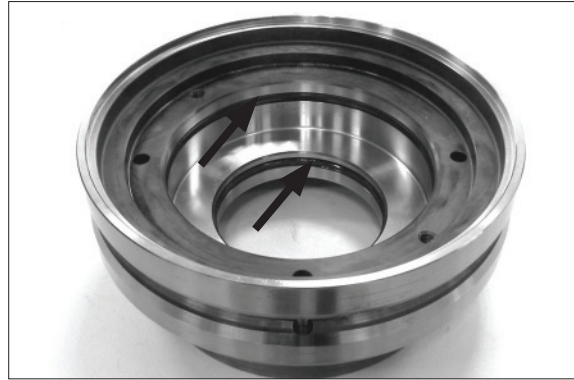

14W7A8TM018

(18) Remove the axial roller cage with both thrust washers.

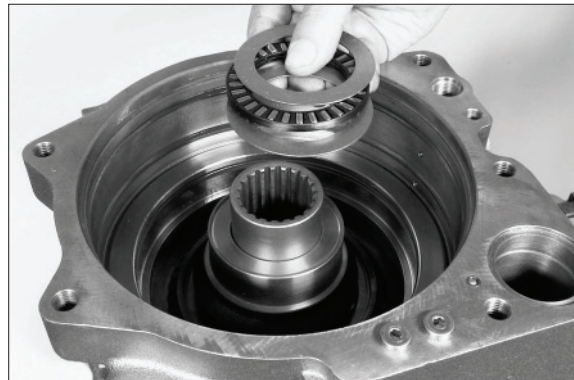

14W7A8TM019

(19) Remove the pressure piece and the compression spring.

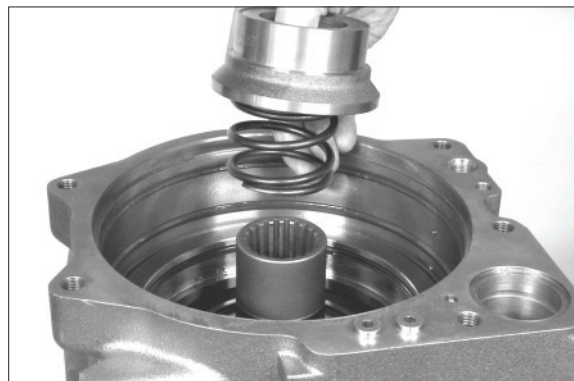

14W7A8TM020

(20) Remove the pressure ring with ring - also see Fig. TM 022 - cautiously by means of lever action - risk of damaging the sealing surfaces !

※ Ring can also remain in the housing- disassemble the ring separately!

(S) Resetting device 5870 400 001

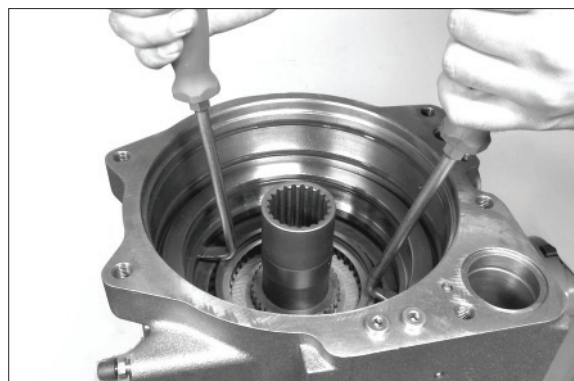

14W7A8TM021

(21) Remove the pressure ring from the ring cautiously by means of lever action - risk of damaging the sealing surfaces !

(S) Resetting device 5870 400 001



14W7A8TM022

(22) Remove the gasket and O-rings from the pressure ring / ring.



14W7A8TM023

(23) Take the disc set of the brake with end shim (s) out of the housing.

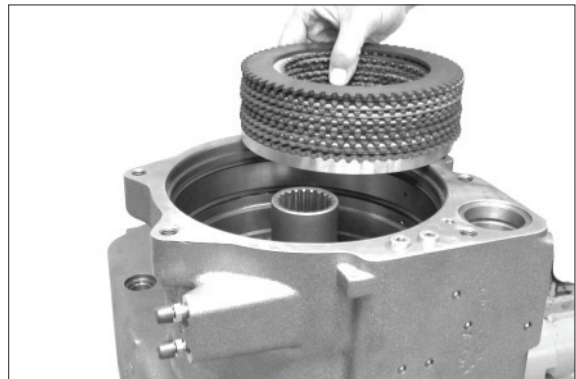

14W7A8TM024

(24) Unsnap the retaining ring.

(S) Clamping pliers 5870 900 021

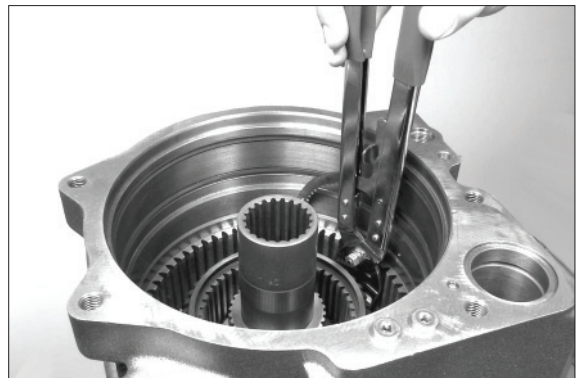

14W7A8TM025

(25) Remove the snap ring and the shim.

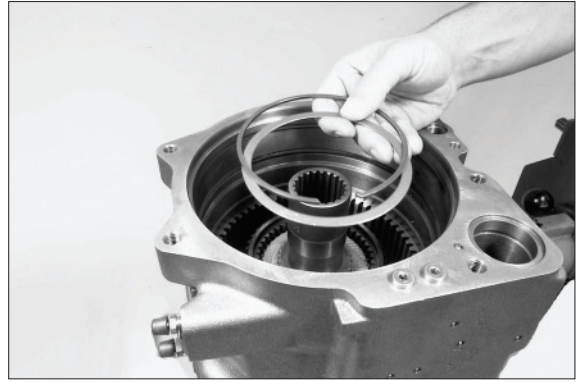

14W7A8TM026

(26) Take the disc set of the clutch (with end shim/s) out of the internal gear.

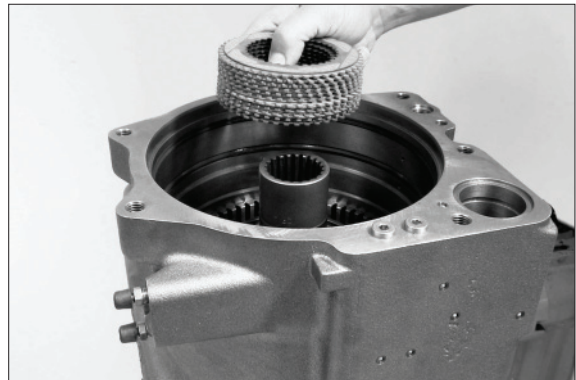

14W7A8TM027

(27) Remove the cpl. input shaft with internal gear from the housing.

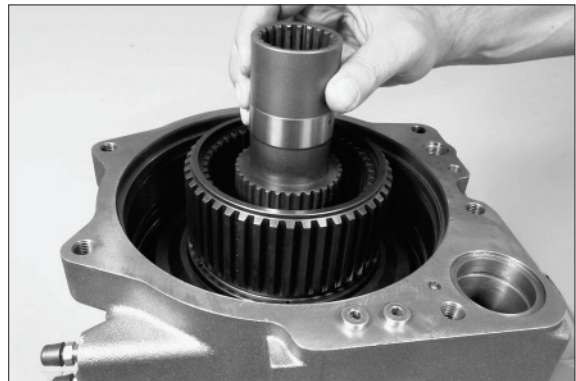

14W7A8TM028

(28) Unsnap the retaining ring.

(S) Set of external pliers 5870 900 015



14W7A8TM029

(29) Press the input shaft out of the ball bearing/internal gear.



14W7A8TM030

(30) Unsnap the retaining ring.

(S) Set of external pliers 5870 900 015



14W7A8TM031

(31) Press the centering disc from the input shaft.

※ In case of an extremely fixed seat - heat the centering disc - disassembly aid !



14W7A8TM032

(32) Unsnap the retaining ring and remove the ball bearing.

(S) Clamping pliers 5870 900 021



14W7A8TM033

(33) Planet carrier :

Remove the axial needle cage with both thrust washers.

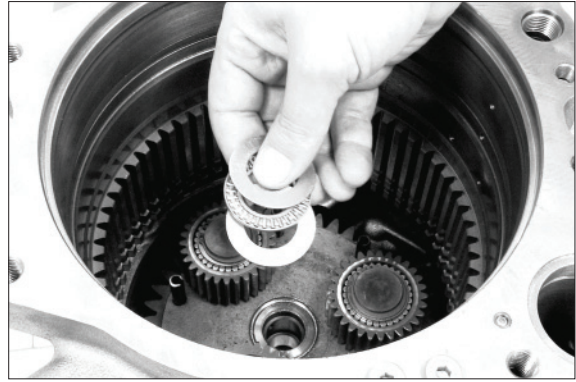

14W7A8TM034

(34) If not yet disassembled before - remove the lube oil pump or the downshift interlock.

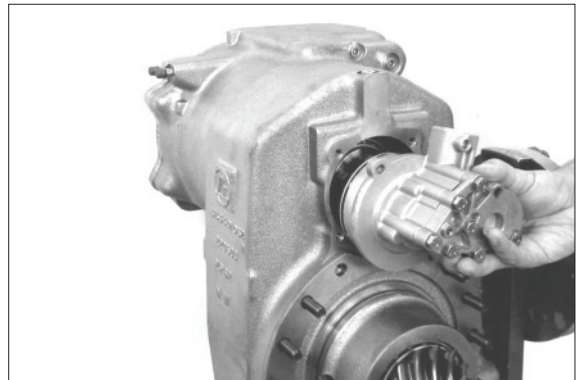

14W7A8TM035

(35) Loosen the bolt connection and remove the washer - fasten the output flange by means of the fixture.

(S) Fixture

5870 240 025

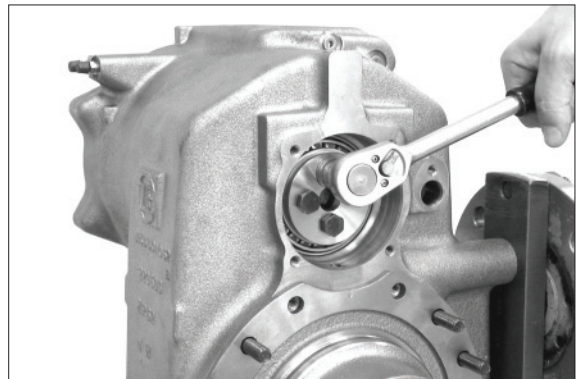

14W7A8TM036

(36) Press the cpl. planet carrier out of the roller bearing.

※ Pay attention to the released planet carrier and the bearing inner ring !

(S) Extractor

5870 000 017

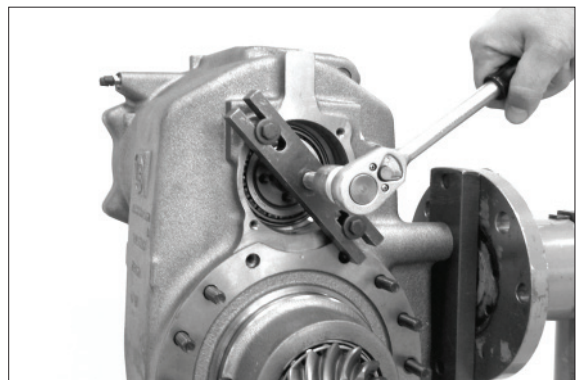

14W7A8TM037

(37) Pull the second bearing inner ring from the planet carrier.

(S) Rapid grip 5873 012 021

(S) Basic tool 5873 002 001



(38) If required - expel both bearing outer rings (arrow) from the bearing bore.

※ If the taper roller bearings are reused - pay attention to the bearing location, i.e. respective bearing inner ring to bearing outer ring !

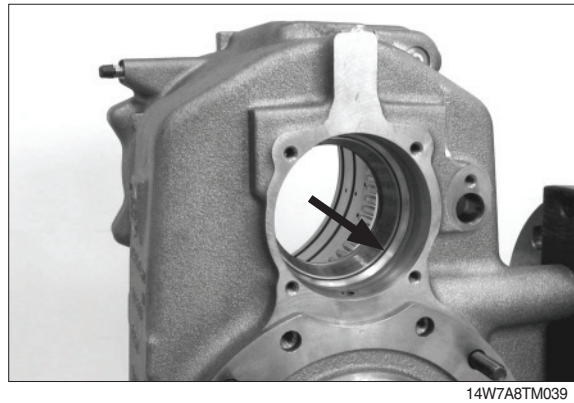

(39) Unsnap the retaining ring.

(S) Set of external pliers 5870 900 015

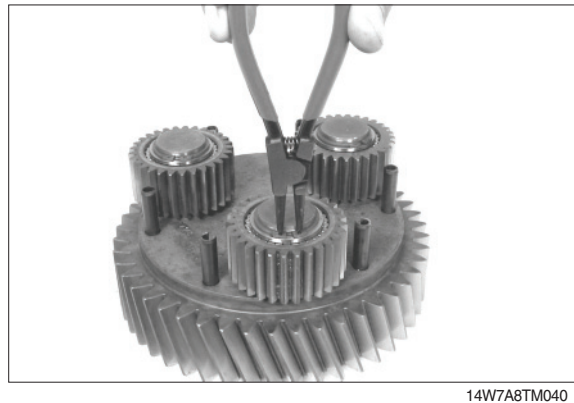

(40) Remove the planetary gear by means of lever action - pay attention to the released shim and the cylindrical rollers !

(S) Resetting device 5870 400 001

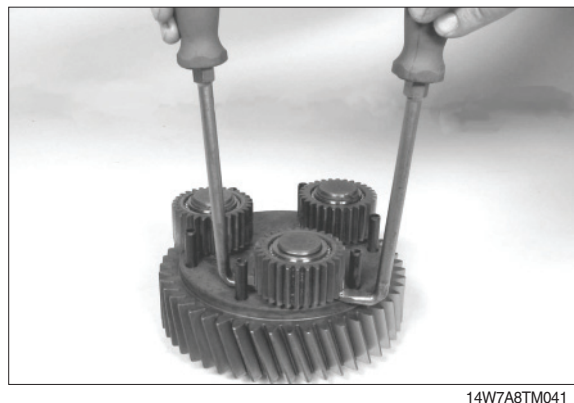

(41) Pull off the bearing inner ring - in case of an extremely fixed seat heat the bearing inner ring.

(S) Three-armed puller 5870 971 003



14W7A8TM042

(42) Remove both seals (1).

Remove both bleeder valves (2) and all screw plugs (3) with sealing and O-ring respectively.

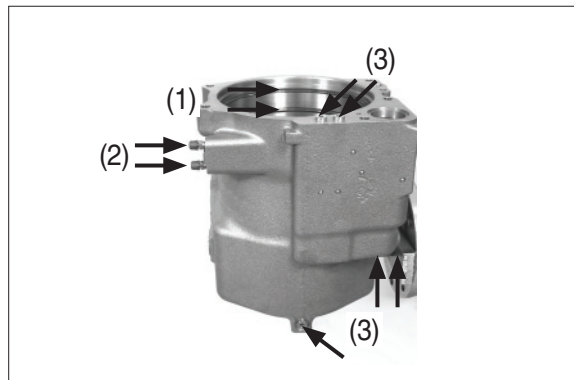

14W7A8TM043

(43) Loosen the countersunk screws and remove the screen sheet.

※ Countersunk screws are installed with locking compound (loctite) - heating for disassembly, if necessary !



14W7A8TM044

(44) Remove the screen sheet (2) from the planet carrier (1).

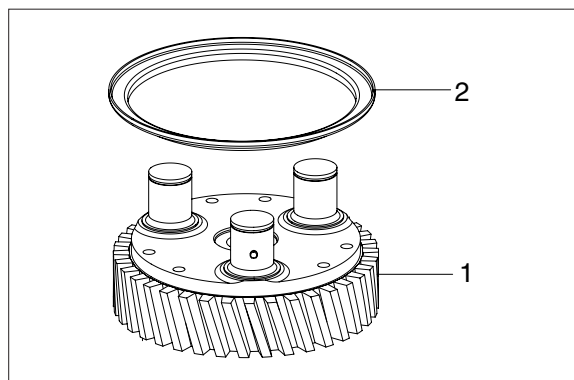

14W7A8TM045

2) REMOVE AND DISASSEMBLE OUTPUT

- (1) 1 = Input
- 2 = Output - Front axle
- 3 = Output - Rear axle

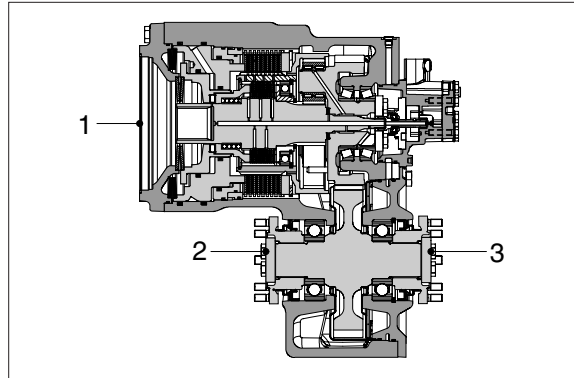

14W7A8TM046

- (2) Fasten the output flange by means of the fixture.
Loosen the bolt connection-pull off washer, O-ring and flange.

(S) Fixture 5870 240 025

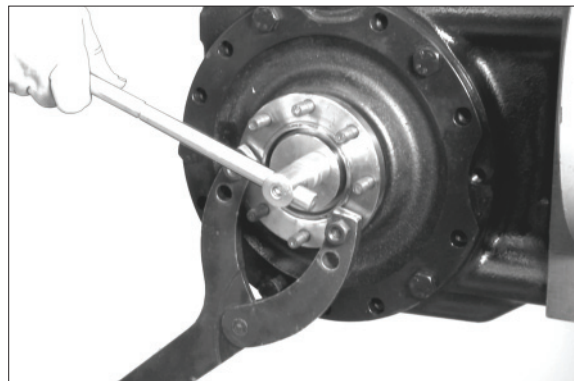

14W7A8TM047

- (3) Press off the shaft by lever action.

※ Install the second output flange and the shaft seal analogously!

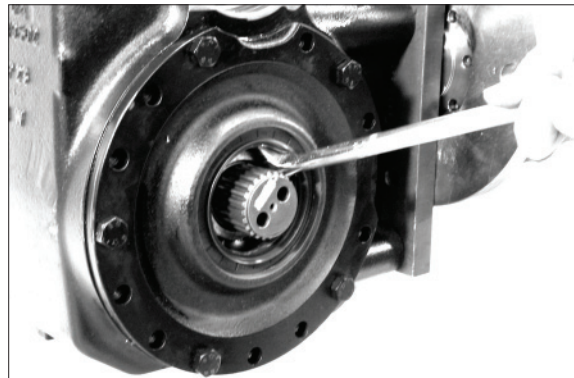

14W7A8TM048

- (4) Loosen the bolt connection.

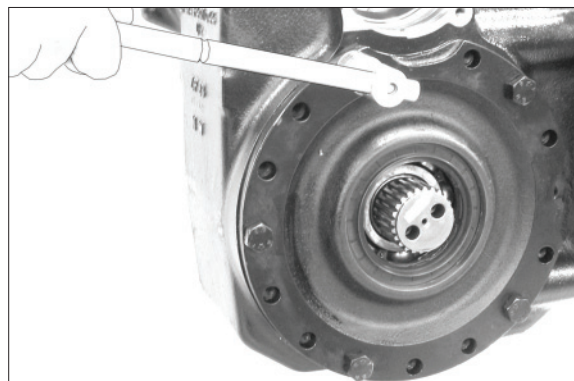

14W7A8TM049

- (5) By means of lifting tackle separate the output gear with cover from the transmission housing.

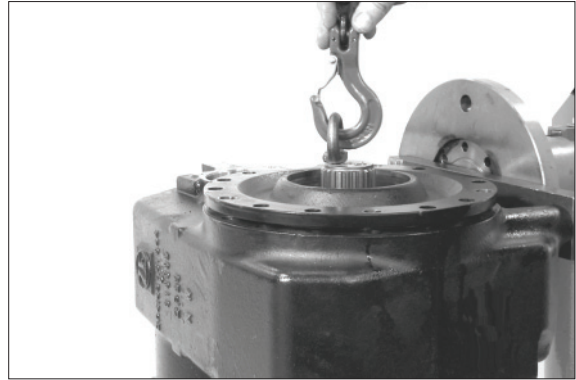

14W7A8TM050

- (6) Press the output gear oil of the ball bearing/cover-remove the released oil baffle plate.

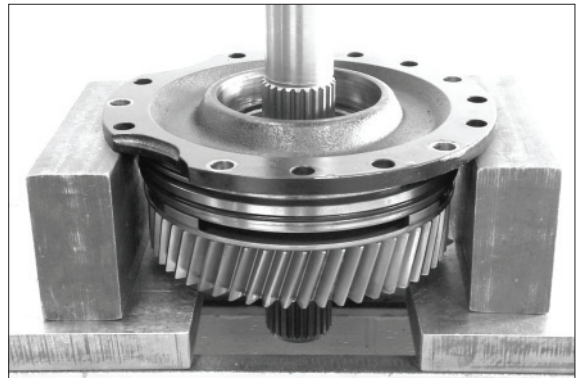

14W7A8TM051

- (7) Unsnap the retaining and expel the ball bearing from the cover.

(S) Set of internal pliers 5870 900 013

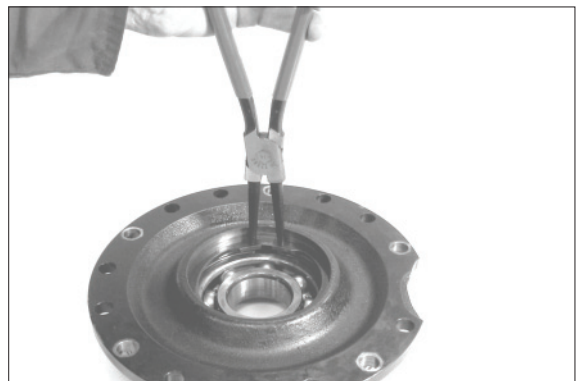

14W7A8TM052

- (8) Remove both O-rings (arrows) from the cover.



14W7A8TM053

(9) Remove the screen sheet from the transmission housing.

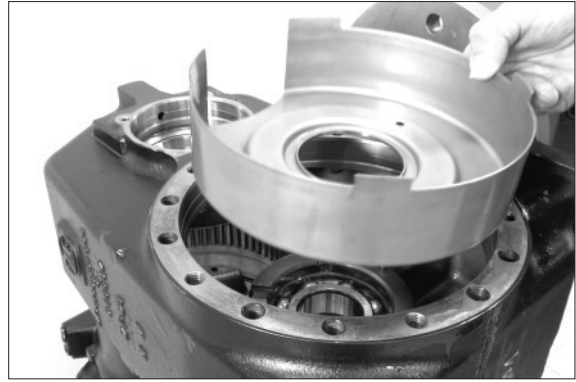

14W7A8TM054

(10) Expel the ball bearing from the housing bore.

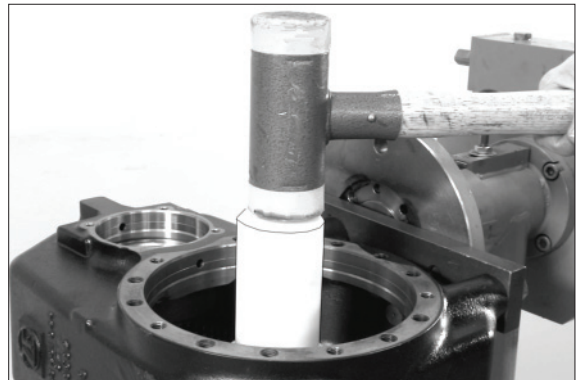

14W7A8TM055

3) REASSEMBLY OUTPUT

- (1) 1 = Transmission housing
- 2 = Ball bearing
- 3 = Screen sheet
- 4 = Cover
- 5 = Ball bearing
- 6 = Retaining ring
- 7 = O-ring
- 8 = Oil baffle plate
- 9 = Output gear
- 10 = Shaft seal
- 11 = Output gear
- 12 = Stud bolt
- 13 = Dirt deflector
- 14 = O-ring
- 15 = Washer
- 16 = Hexagon screw

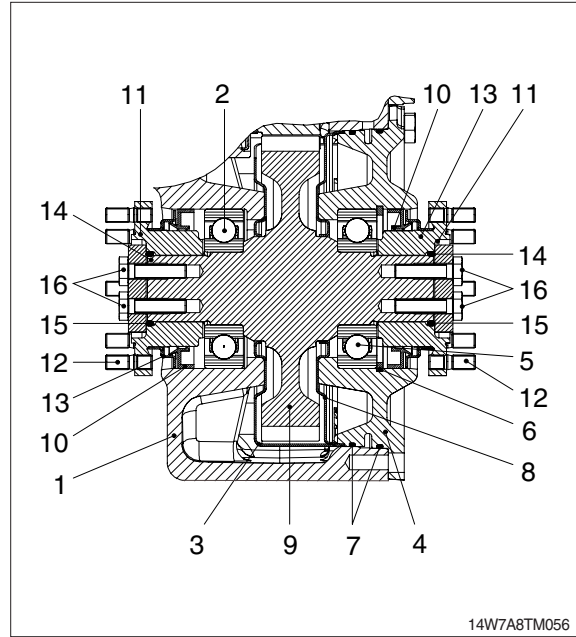

- (2) Insert ball bearing (2) until contact is obtained.

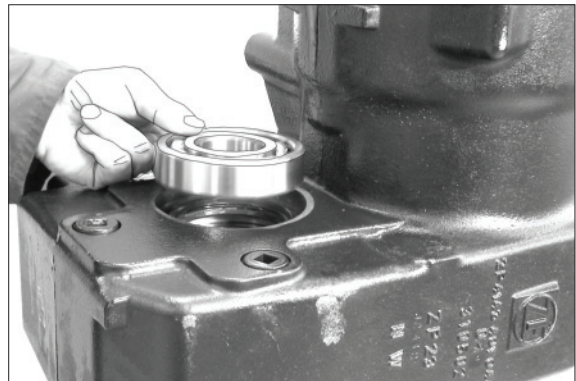

- (3) Rotate the transmission by 180°.
- ※ Insert the slotted pin (arrow).

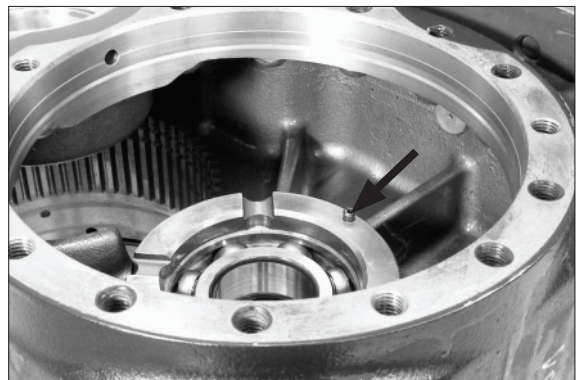

(4) Position the screen sheet-with slotted pin (see figure TM 058) into the fixing bore (arrow).

※ Observe the installation position - slotted pin = radial fixing of the screen!

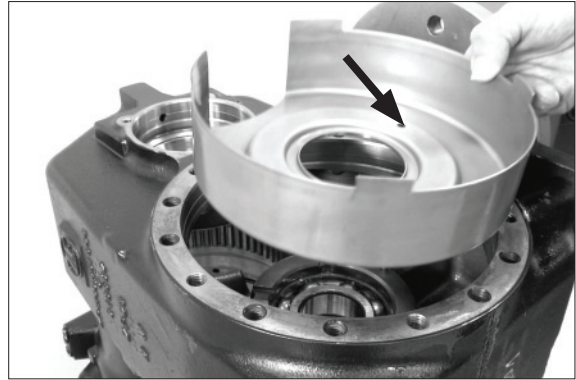

14W7A8TM059

(5) Insert the ball bearing into the cover and fasten it by means of the retaining ring.



14W7A8TM060

(6) Oil both O-rings (arrows) and put it into the ring grooves of the planet carrier.



14W7A8TM061

(7) Bend the edges of the fixing of the oil baffle plate slightly-assembly aid (sheet is fixed to the bearing cover see figure TM 063).



14W7A8TM062

(8) Mount the oil baffle plate on the bearing cover.

- ※ Observe the installation position - locate the fixing lug (arrow) into the recess of the bearing cover (radial fixing!).

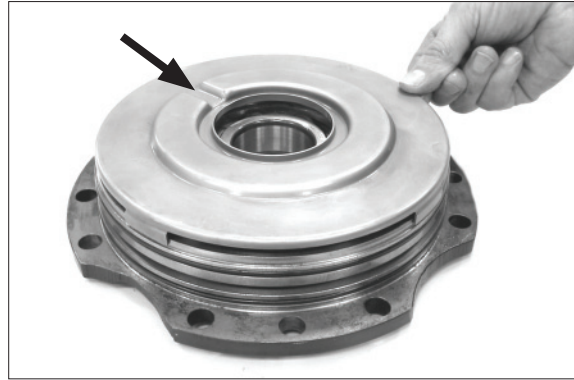

14W7A8TM063

(9) Press the output into the ball bearing / bearing cover.

- ※ Rest the ball bearing against the bearing inner ring!

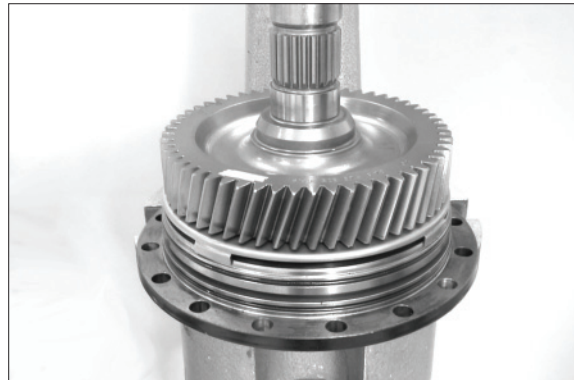

14W7A8TM064

(10) Heat the bearing inner ring of the bearing.

- (S) Hot-air blower 230V 5870 221 500
- (S) Hot-air blower 115V 5870 221 501



14W7A8TM065

(11) Attach two adjusting screws (M12) and mount the preassembled bearing cover/ output gear until contact is obtained.

- (S) Adjusting screws (M12) 5870 204 021

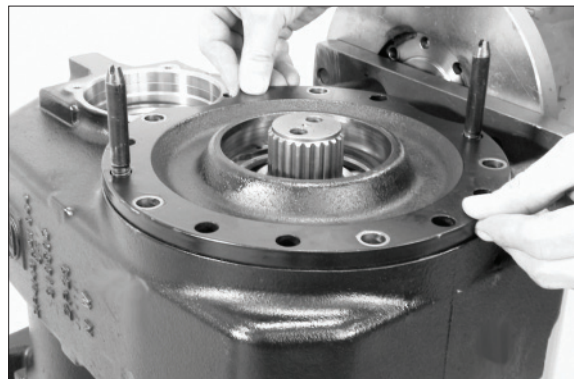

14W7A8TM066

(12) Fasten the bearing cover by means of hexagon screws.

- Tightening torque (M12/8.8) :
8.2 kgf · m (59 lbf · ft)

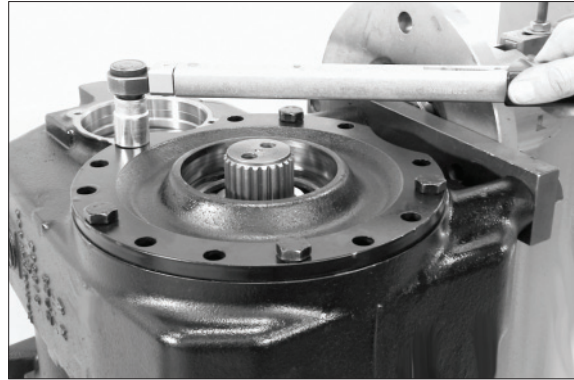

14W7A8TM067

(13) Shaft seal / Output flange :

- 1 = Shaft seal
- 2 = Screen sheet
- 3 = Flange
- 4 = Ball bearing
- 5 = Bearing cover

M = Installation dimension → 17.6_{-0.5}mm

N = Installation dimension → 27.5^{+0.3}mm

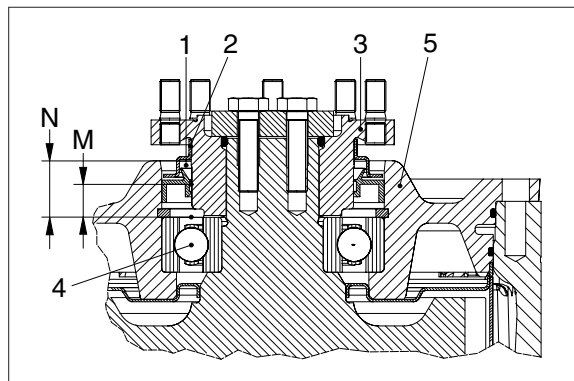

14W7A8TM068

(14) Contact face (external shell of the shaft seal) if :

- Rubberized ⇒ to be wet with spirit
- Metal ⇒ to be provided with sealing compound (Loctite No. 586).

- ※ Installation position of the shaft seal - Sealing lip showing to the oil pump (above figure).
- ※ Install the shaft seal (1) considering the required installation position (Dim. M above figure)
- ※ Grease the shaft seal in the area around the sealing and dust lip.

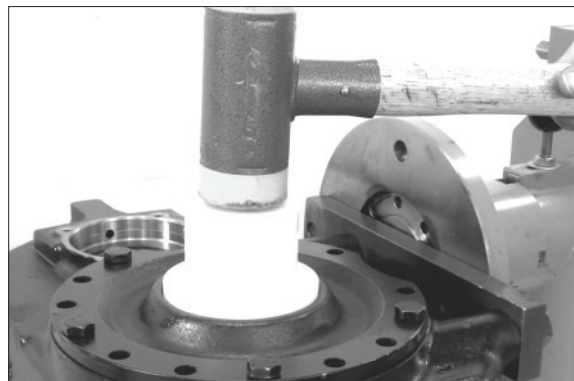

14W7A8TM069

(15) Exact installation position of the shaft seal is guaranteed by use of the specified mounting tool!

(S) Mounting tool 5870 048 279

- ※ Only for installation of a new flange or if stud bolts were removed.
- ※ Install the stud bolts.
Installation position-stud bolts with short thread length into flange!

- Tightening torque (M10 × 1) :
2.04 kgf · m (14.8 lbf · ft)



14W7A8TM070

(16) Only for installation of a new flange / screen sheet or if removed :

Install the screen sheet (2), considering the required installation position (Dim. N - See TM 069).

※ Exact installation position of the screen sheet is guaranteed by use of the specified mounting tool!

(S) Mounting tool 5870 506 150

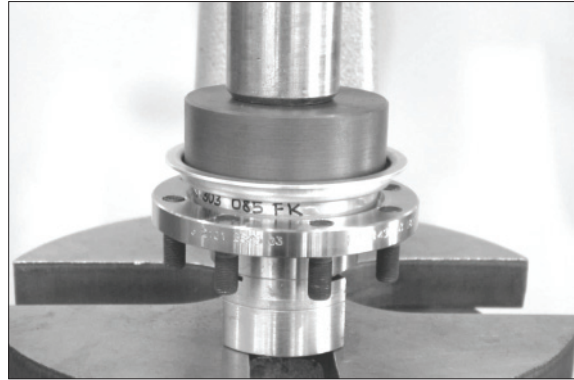

14W7A8TM071

(17) Mount the preassembled output flange.

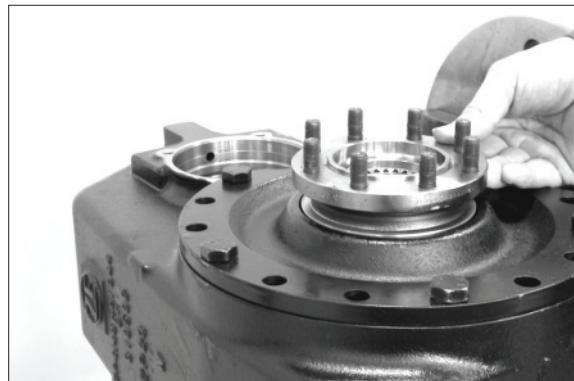

14W7A8TM072

(18) Insert the O-ring.

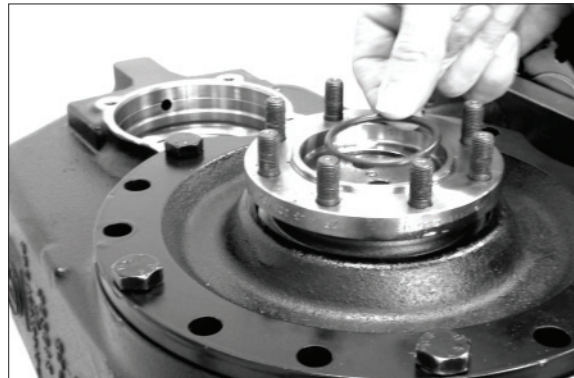

14W7A8TM073

(19) Position the washer and fasten the output flange by means of hexagon screws.

※ Install the second shaft seal / output flange (front axle output) analogously.

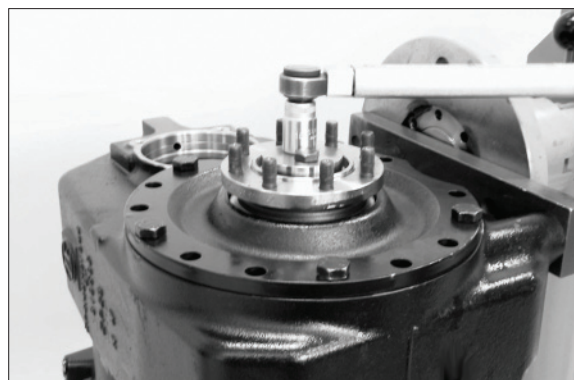

14W7A8TM074

4) REASSEMBLY BRAKE / CLUTCH / PLANET CARRIER

(1) PLANET CARRIER

Install the bearing outer until contact.

- ※ Observe the bearing location-bearing inner ring to bearing outer ring-also see instructions for disassembly page 8-101, TM039.

(S) Mounting tool 5870 058 051
 Handle 5870 260 002

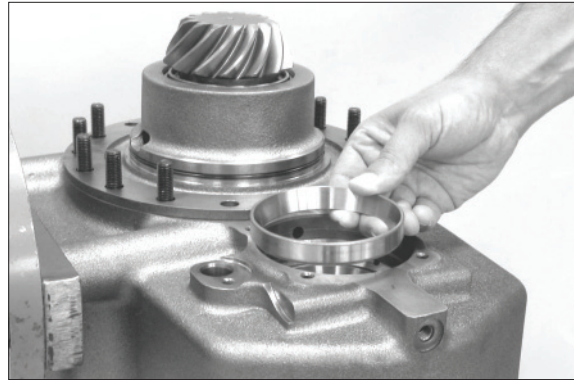

14W7A8TM075

(2) Rotate transmission by 180°.

Install the second bearing outer ring until contact.

- ※ Observe the bearing location-bearing inner ring to bearing outer ring-also see instructions for disassembly page 8-101, TM039.

(S) Mounting tool 5870 058 051
 Handle 5870 260 002

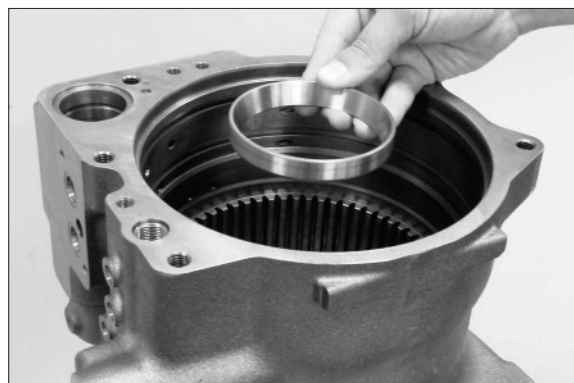

14W7A8TM076

(3) Insert the screen sheet and fasten it with countersunk screws.

- ※ Secure the countersunk screws with locking compound (loctite No. 243)!



14W7A8TM077

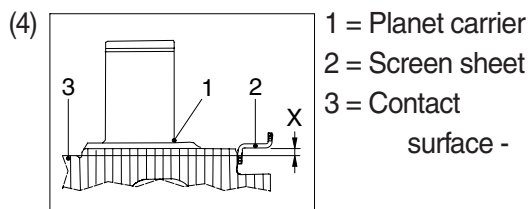

Axial needle cage / axial washer

X = Installation dimension → 1.5_{-0.5}mm

Install the screen sheet (2) considering the installation dimension X onto the planet carrier (1).

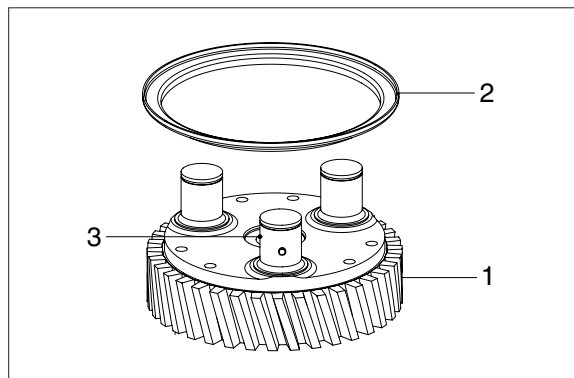

14W7A8TM078

- (5) Insert the slotted pins (6x), considering the installation dimension $X=28.0_{-1.0}mm$ and the installation position see sketch No. 6 (slot is showing to the center).

Prior to installation grease the slotted pin-assembly aid!

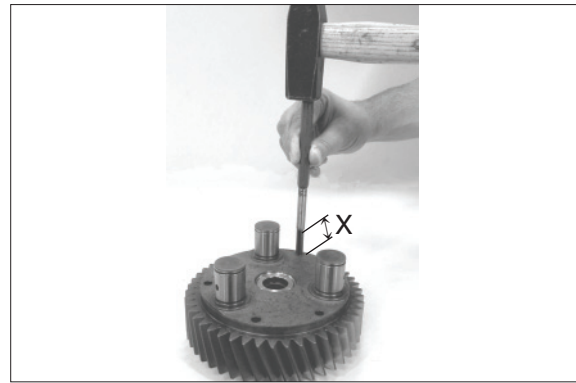

14W7A8TM079

- (6) 1 = Planet carrier
2 = Slotted pins (6x)
3 = Center (planet carrier)

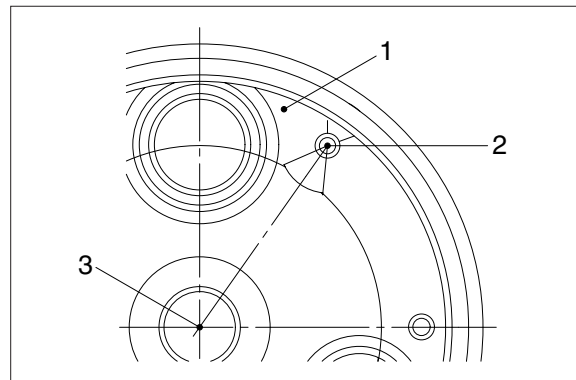

14W7A8TM080

- (7) 1 = Bearing inner ring with cylinder rollers
1a = Packing sleeve + assembly aid
3 = Cylinder rollers
3a = Packing sleeve + assembly aid
4 = Shim

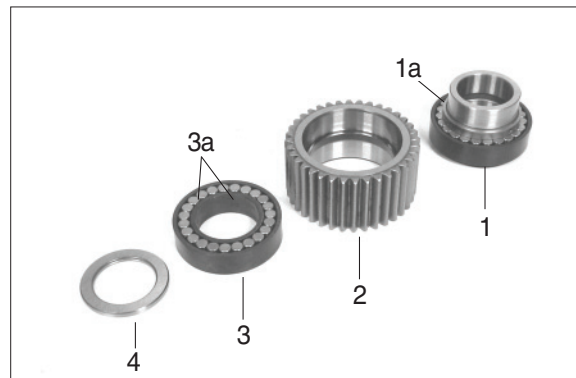

14W7A8TM081

- (8) Position the planetary gear (2) with the marking showing downwards.
Put the bearing inner ring (1) onto the planetary gear (2) and press it until contact is obtained.

Then remove the loose packing sleeve (1a).

- ※ Keep the bearing inner ring to contact and rotate the planetary gear by 180°



14W7A8TM082

- (9) Position the cylinder rollers (3) onto the planetary gear (2).

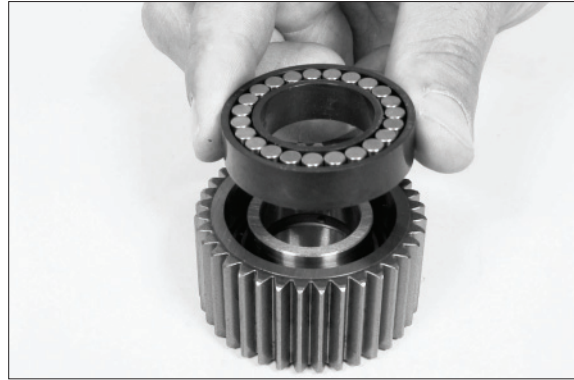

14W7A8TM083

- (10) By means of the mounting tool press the cylinder rollers (2) into the planetary gear (2).
Then remove the two loose packing sleeves (3a).

(S) Mounting tool 5870 048 282

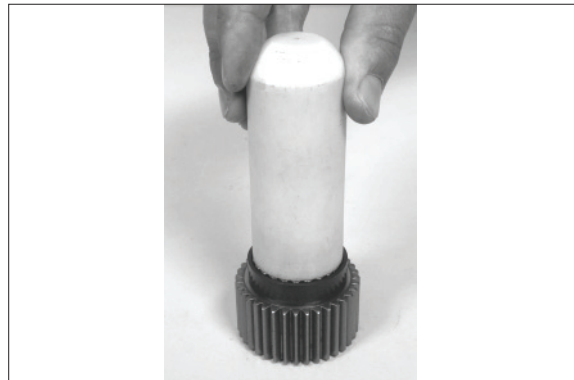

14W7A8TM084

- (11) Keep the bearing inner ring with cylinder rollers to contact and mount the preassemble the planetary gear to the planet carrier pin.

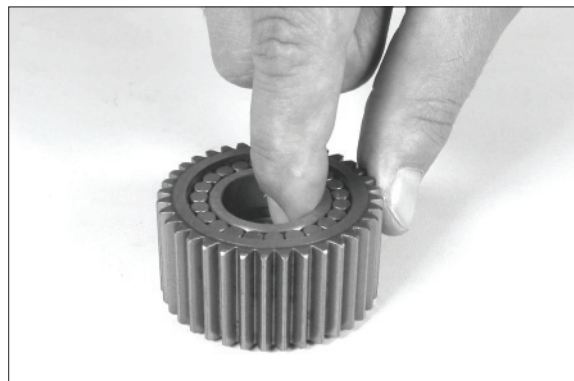

14W7A8TM085

- (12) Press the planetary gear (bearing inner ring) until contact.

(S) Mounting tool 5870 048 282

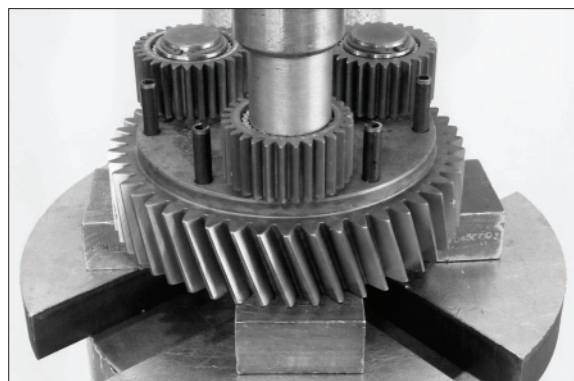

14W7A8TM086

(13) Mount the shim (4) marking showing upwards- and snap in the retaining ring.

※ Install the retaining ring subsequently until contact at the groove base is obtained.

Install the remaining planetary gear analogously.

(S) Set of external pliers 5870 900 015

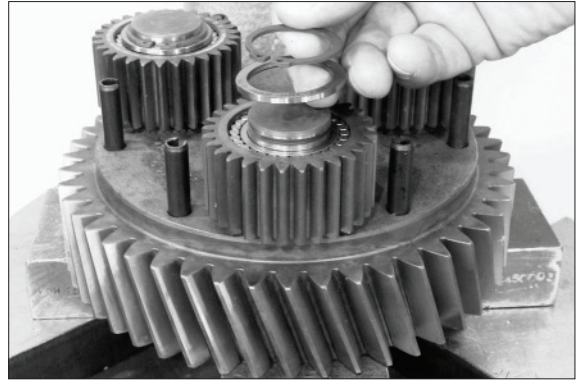

14W7A8TM087

(14) Press the bearing inner ring onto the planet carrier until contact is obtained.

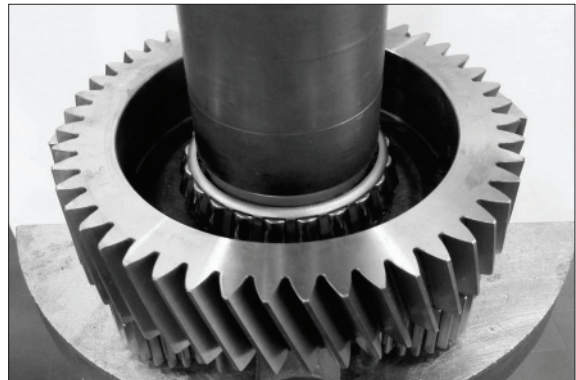

14W7A8TM088

(15) Insert the preassembled planet carrier.

(S) Set of external pliers 5870 900 015



14W7A8TM089

(16) Fasten the planet carrier by means of pressure plate and clamping bar.

(S) Clamping bar 5870 654 049



14W7A8TM090

(17) Rotate the transmission by 180°.

Check locating of the bearing outer ring (arrow) - installation of the bearing outer ring-see TM 075.

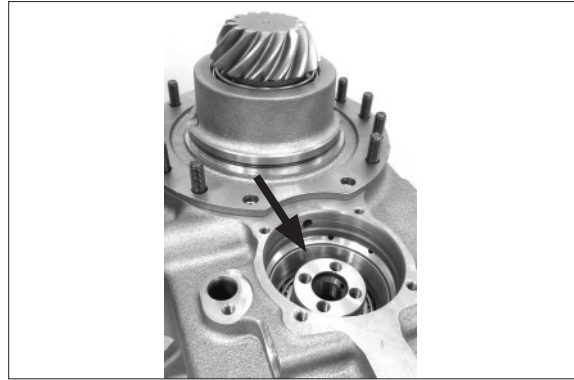

14W7A8TM091

(18) Mount the heated bearing inner ring until contact.

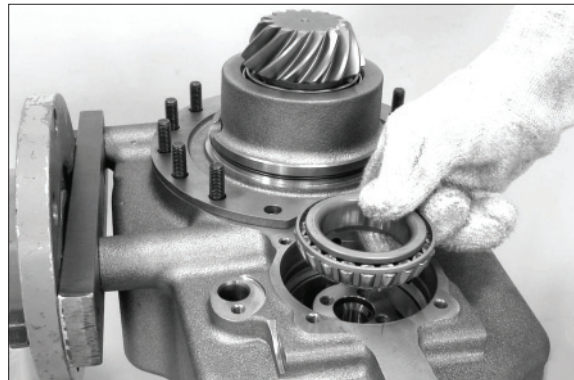

14W7A8TM092

(19) Position the shim and attach the hexagon screws by hand (fixing of the planet carrier).

Then remove the clamping bar - see figure TM 090.

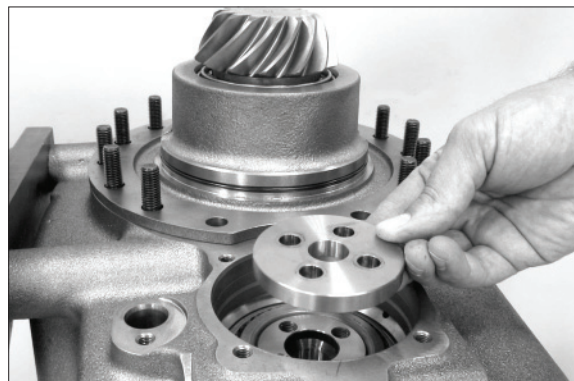

14W7A8TM093

(20) Fasten the fixture to the output flange.

Tighten the hexagon screws equally-risk of distortion!

- Tightening torque (M 10/8.8) :
4.7kgf · m (34lbf · ft)

※ When tightening the hexagon bolts rotate the planet carriers into both directions several times (aligning of rollers)!

(S) Fixture 5870 240 025

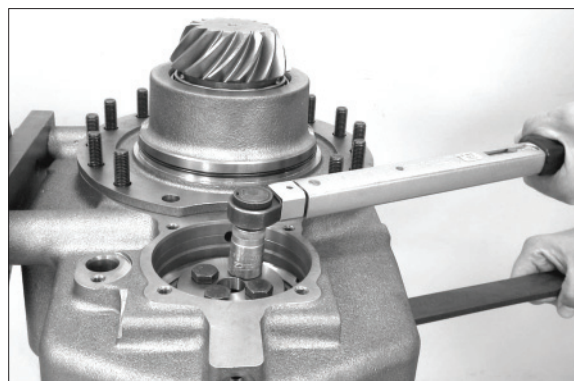

14W7A8TM094

(21) Brake / Clutch :

Mount the heated centering disc and press it until contact is obtained.

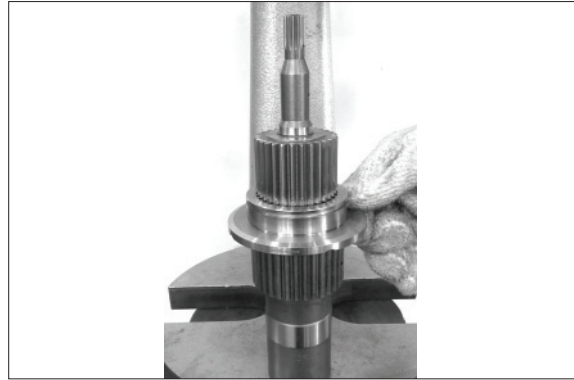

14W7A8TM095

(22) Fasten the centering disc by means of the retaining ring.

(S) Set of external pliers 5870 900 015



14W7A8TM096

(23) Insert the ball bearing into the internal gear and fasten it by means of the retaining ring.

(S) Clamping pliers 5870 900 021



14W7A8TM097

(24) Heat the bearing inner ring of the ball bearing.

(S) Hot-air blower (230V) 5870 221 500

(S) Hot-air blower (115V) 5870 221 501



14W7A8TM098

(25) Mount the preassembled internal gear to the input shaft until contact is obtained.



14W7A8TM099

(26) Snap in the retaining ring.

(S) Set of external pliers 5870 900 015



14W7A8TM100

(27) Rotate the transmission by 180°.

Position the axial needle cage with both thrust washers (1x each, underneath and onto the axle needle cage respectively).

※ Fix the axial needle cage and the thrust washers by means of grease centrally assembly aid!

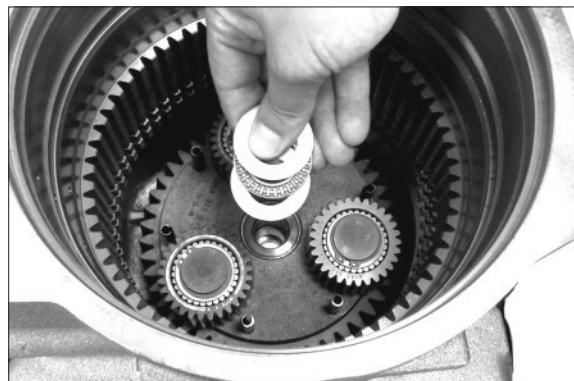

14W7A8TM101

(28) Mount the preassembled input shaft (with internal gear).



14W7A8TM102

(29) Disc components brake and clutch :

A = lower ring groove (Item retaining ring-1)
 B = Upper ring groove (Item retaining ring-1)

- 1 = Retaining ring
- 2 = End shim / Brake (1 Pc.)
- 3 = Outer disc / Brake (6 Pcs.)
- 4 = Inner disc / Brake (6 Pcs.)
- 5 = End shim / Clutch (1 Pc.)
- 6 = Inner disc / Clutch (10 Pcs.)
- 7 = Inner disc / Clutch (9 Pcs.)
- 8 = Transmission housing
- 9 = Disc carrier / Internal gear

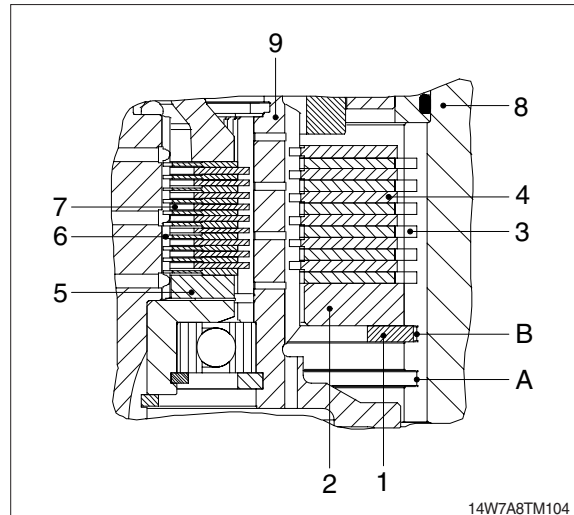

14W7A8TM104

(30) Brake

Snap the retaining ring (1) into the ring groove (A).

(S) Clamping pliers 5870 900 021

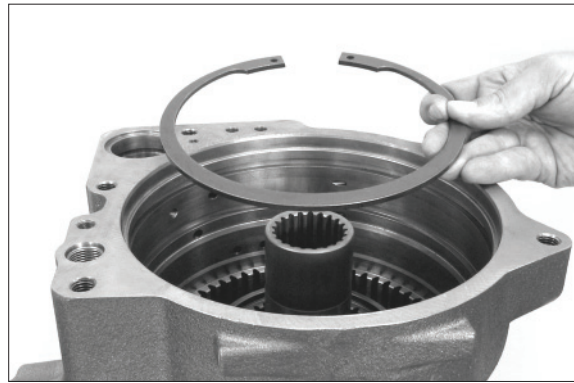

14W7A8TM105

(31) Insert the end shim (2).



14W7A8TM106

(32) Insert the disc set (outer/inner discs)-beginning with an outer disc alternately.

※ Position the outer disc (1 Pc) s = variable 2.8~3.7 mm, in the disc set on the top (piston-side)!

With outer disc s = variable, the disc clearance / piston stroke will be adjusted - sec figure TM 120.



14W7A8TM107

(33) Clutch :

Insert the disc set (outer / inner discs)-beginning with an outer disc alternately.

- ※ Position the outer disc (1 Pc.) s = variable 1.2~1.6 mm, in the disc set on the top (piston side)!

With outer disc s = variable, the disc clearance / piston stroke will be adjusted -see figure TM 119.

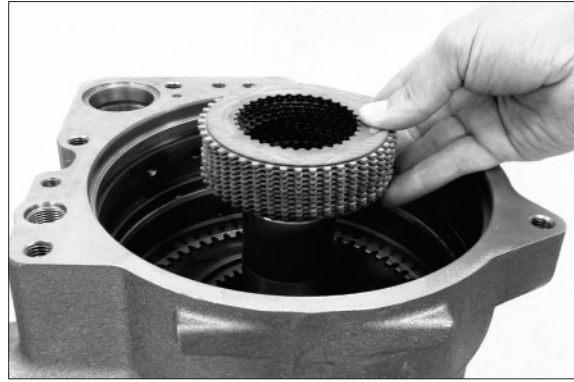

14W7A8TM108

(34) Adjust and check the disc clearance / piston stroke of brake and clutch :

Mount the pressure piece (without compression spring).

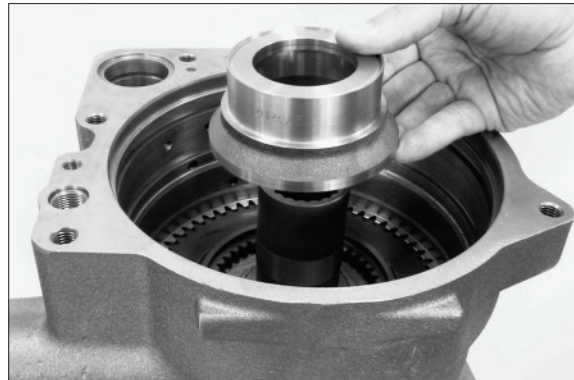

14W7A8TM109

(35) Oil the axial roller and mount it with both thrust washers (1x each, positioned underneath and onto the axial needle cage respectively).



14W7A8TM110

(36) Insert the piston (brake) without sealing elements installed.



14W7A8TM111

(37) Insert the piston (clutch) - without sealing elements installed.



14W7A8TM112

(38) Insert both cup springs / clutch.
Fix the cup springs by means of grease and position them centrally - assembly aid.

※ Observe the installation position - also see TM 115.

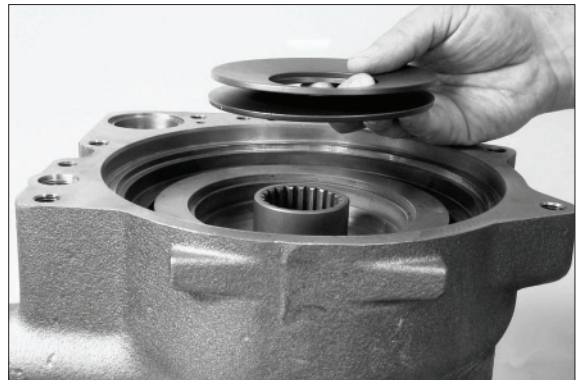

14W7A8TM113

(39) Insert both cup springs / brake.
Fix the cup springs by means of grease and position them centrally - assembly aid.

※ Observe the installation position - also see TM 115.



14W7A8TM114

- (40) 1 = Measuring fixture
 2 = Piston/Clutch
 3 = Cup springs/Clutch
 4 = Piston/Brake
 5 = Cup springs/Brake
 6 = Transmission housing
 I = Measuring bore (Dix clearance/Clutch)
 II = Measuring bore (Dix clearance/Brake)
 A = Mounting face / Housing - Face/Piston
 B = Mounting face / Housing - Piston contact / Housing
 C = Mounting face / Housing - Face/Piston
 D = Mounting face / Housing - Piston contact / Housing
 Y = Disc clearance/clutch $2.4^{+0.3}$ mm (piston stroke)
 X = Disc clearance/brake $1.8^{+0.3}$ mm (Piston stroke)

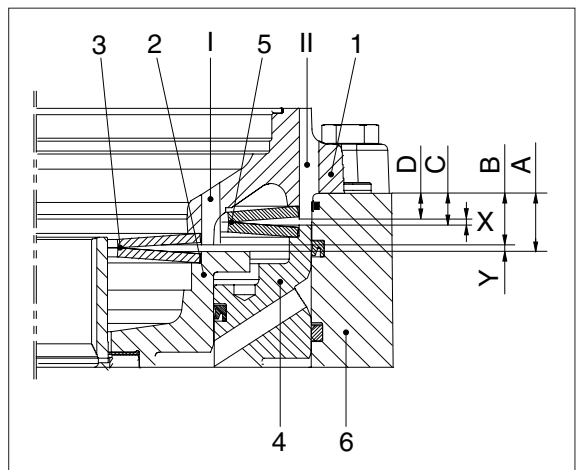

14W7A8TM115

(41) Locate the measuring fixture with hexagon screws equally (risk of breakage) until contact is obtained.

- Tightening torque (M 12/8.8) :
8.2 kgf · m (59 lbf · ft)

(S) Measuring fixture 5870 200 131

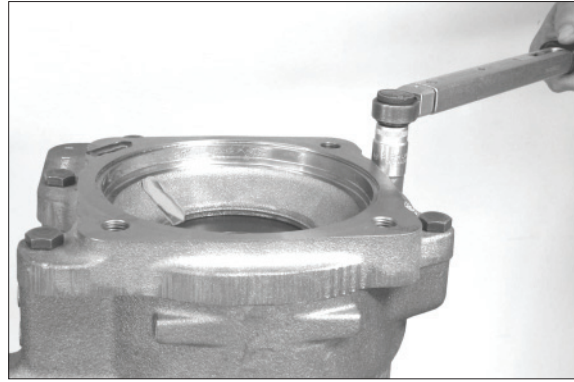

14W7A8TM116

(42) Determine Dim. A (measuring bore I) from mounting face / housing to the face / piston (clutch).

Dim. A e.g. = 22.45 mm

(S) Digital depth gauge 5870 200 072

(S) Straightedge 5870 200 022

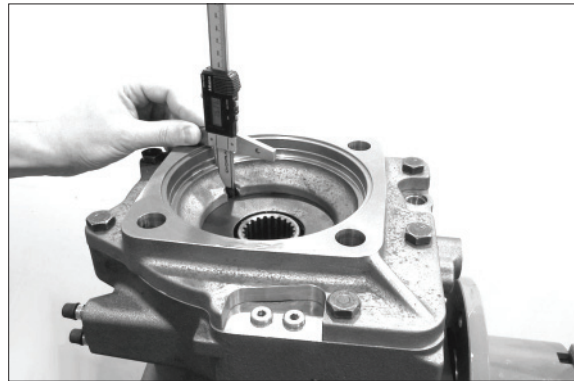

14W7A8TM117

(43) Determine Dim. C (measuring bore II) from mounting face/housing to the face/ piston (brake).

Dim. C e.g. = 11.85 mm

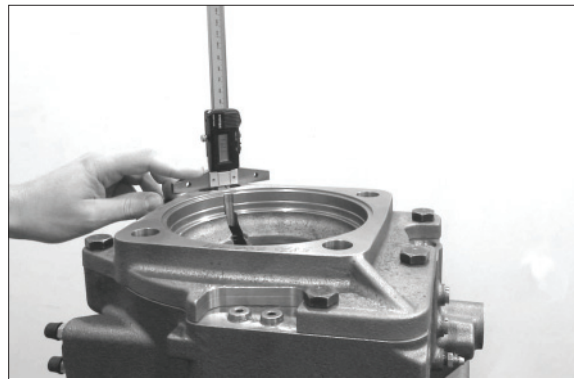

14W7A8TM118

(44) Determine Dim. B from mounting face/ housing to clutch piston contact /housing.

Dim. B e.g. = 19.95 mm

Example :

Dim. A e.g. = 22.45 mm

Dim. B e.g. = 19.95 mm

Result = 2.50mm

Clutch disc clearance (piston stroke) = $2.4^{+0.3}$ mm

※ If the required disc clearance (piston stroke) is not to be obtained, this is to be corrected with a suitable outer disc - see figure TM 108.

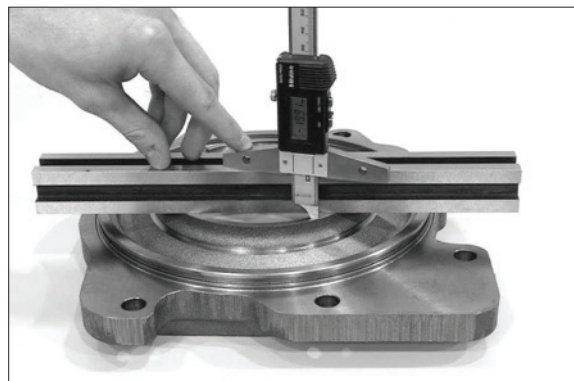

14W7A8TM119

(45) Determine Dim. D from mounting face/
housing to clutch piston contact /housing.

Dim. D e.g. = 9.95 mm

Example :

Dim. C e.g. = 11.85 mm

Dim. D e.g. = 9.95 mm

Result = 1.90 mm

Disc clearance (piston stroke) Brake = $1.8^{+0.3}$ mm

※ If the required disc clearance (piston stroke) is not to be obtained, this is to be corrected with a suitable outer disc - see figure TM 108.

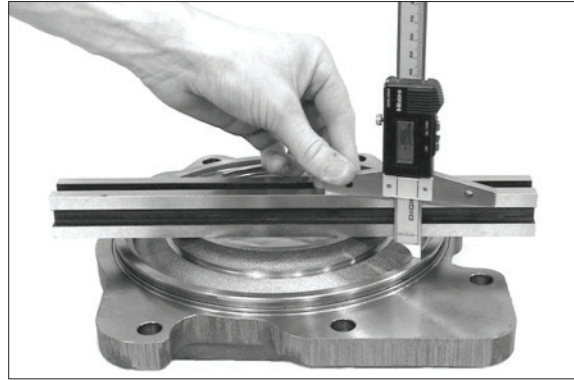

14W7A8TM120

(46) Remove the measuring fixture again-
loosen the screws equally.

Remove all cup springs, both pistons,
axial roller cage with thrust washers and
pressure piece.

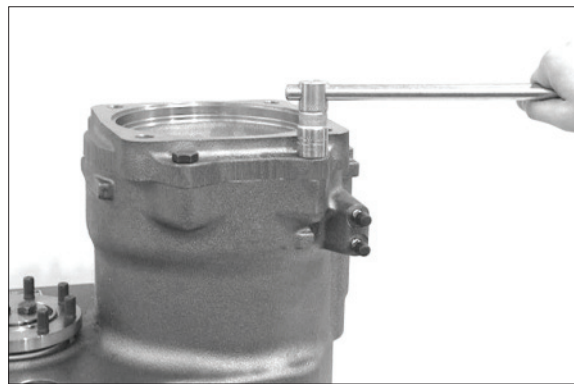

14W7A8TM121

(47) Insert the oil baffle plate into the disc
carrier and fix it with the snap ring.

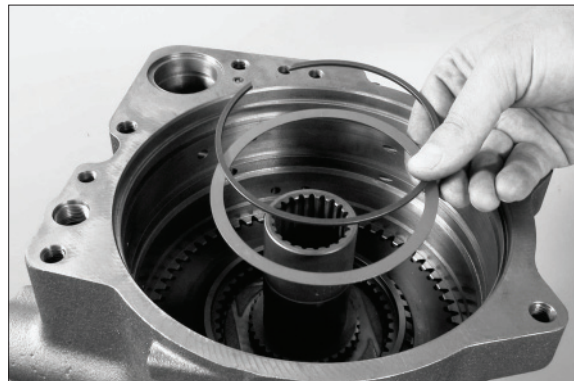

14W7A8TM122

(48) Oil the sealing faces and the O-ring.
Insert the O-ring (arrow) into the groove
and insert the ring.

※ Observe the installation position - see
figure TM124.



14W7A8TM123

(49) By means of the mounting tool locate the ring until contact is obtained.

(S) Mounting tool 5870 506 161

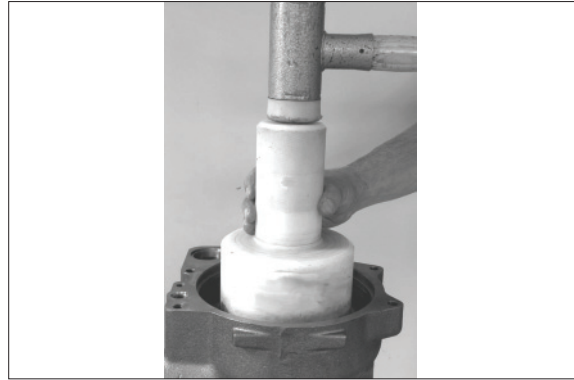

14W7A8TM124

(50) Oil the sealing faces and the sealing elements.

Insert the seal (1) with the sealing lip showing to the oil sump-also see detail sketch.

Put both O-rings (2) into the ring grooves of the pressure ring (3) and insert the preassembled pressure ring-observe the installation position.

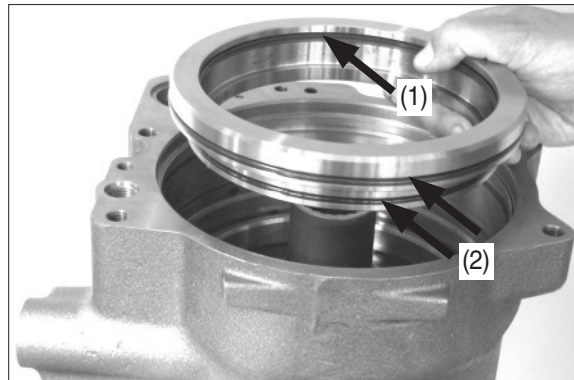
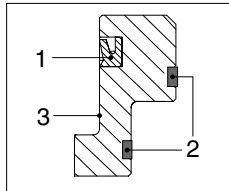

14W7A8TM125

(51) By means of the mounting tool locate the pressure ring until contact.

(S) Mounting tool 5870 506 161



14W7A8TM126

(52) Insert the compression spring.



14W7A8TM127

(53) Insert the pressure piece.



14W7A8TM128

(54) Oil the axial roller cage and mount it with both thrust washers (1x each to be positioned underneath and onto the axial needle cage respectively).



14W7A8TM129

(55) Oil the sealing faces and the sealing elements.
Insert the seal (2, with the sealing lip showing to the oil sump) and the seal (3)-see figure TM 131 - into the housing (1).

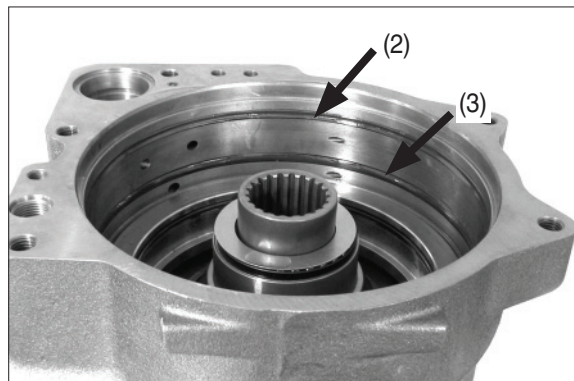

14W7A8TM130

(56) 1 = Housing
2 = Seal (with sealing lip)
3 = Seal
4 = Piston/Brake
5 = Seal (with sealing lip)
6 = Seal (with sealing lip)
7 = Piston/Clutch

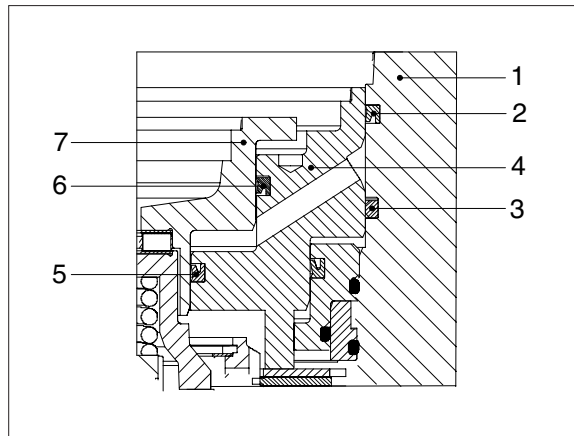

14W7A8TM131

(57) Oil the sealing faces and the sealing elements.

Insert the seals (5 and 6, see figure TM131), with the sealing lip showing to the oil sump, into the piston/brake (4).

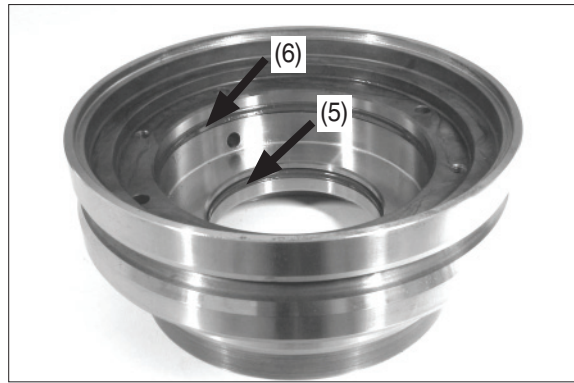

14W7A8TM132

(58) Insert the preassembled piston/brake until contact is obtained.

※ Piston is to be positioned that the oil supply bore (arrow) - with the HL-Transmission installed into the machine is at 12.00 o'clock position!

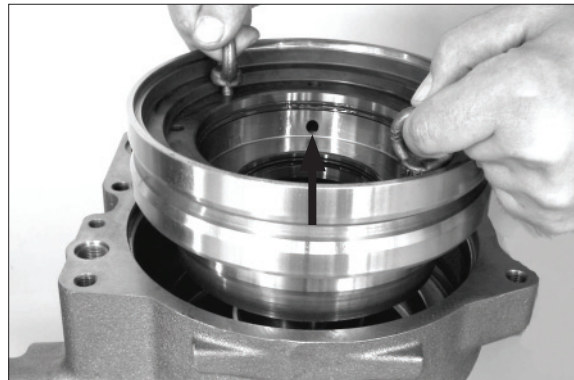

14W7A8TM133

(59) By means of the mounting tool locate the piston until contact.

(S) Mounting tool 5870 506 161



14W7A8TM134

(60) Insert both cylinder pins (arrow).



14W7A8TM135

(61) Insert the piston/clutch.

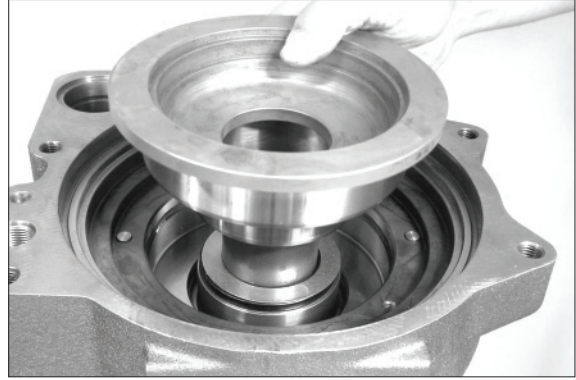

14W7A8TM136

(62) Press the piston axially, contrary to the compression spring preload, and seal the pressure oil supply bore by means of screw plug/sealing ring (arrow)-thus the piston is kept in axial position-assembly aid for input housing assembly (figure TM143+TM144).

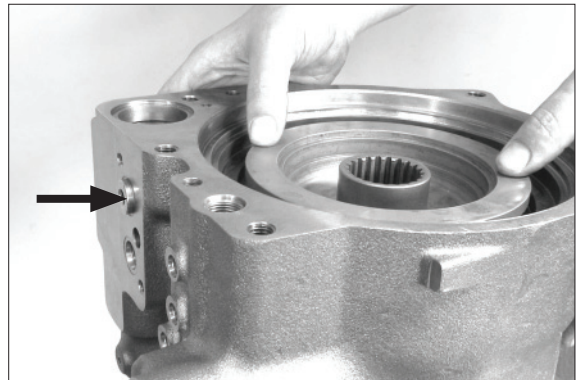

14W7A8TM137

(63) Insert both cup springs/ clutch.

※ Observe the installation position - see figure TM115 respectively.

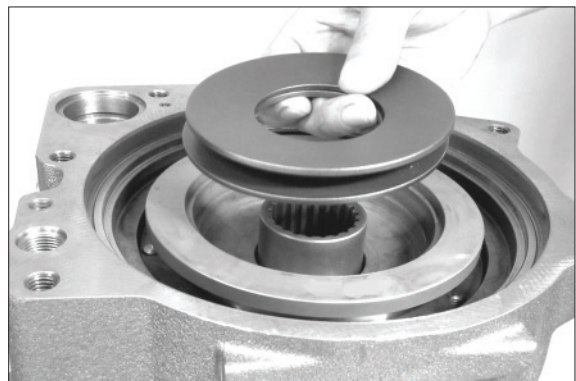

14W7A8TM138

(64) Insert both cup springs/ brake.

※ Observe the installation position - see figure TM115.

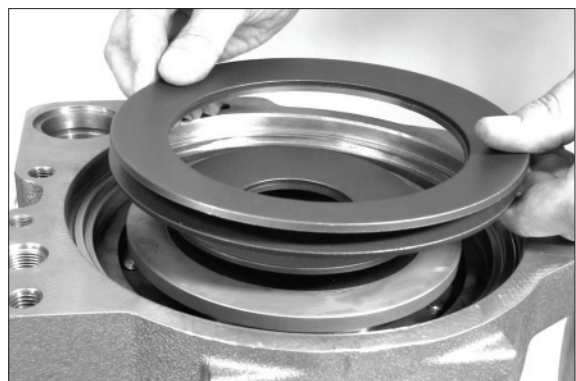

14W7A8TM139

(65) Modulation valve and input housing :

Insert the modulation valve (cpl. - can only be replaced as unit).

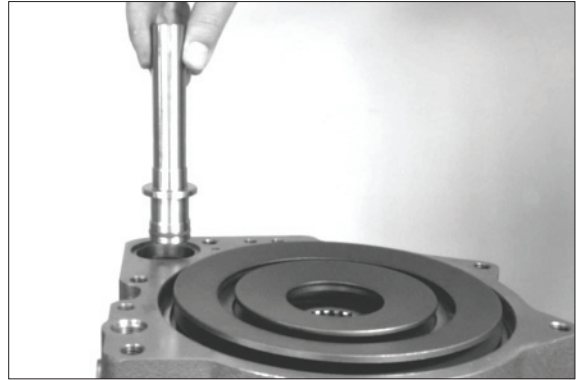

14W7A8TM140

(66) Place the O-ring (arrow) and insert the compression spring.

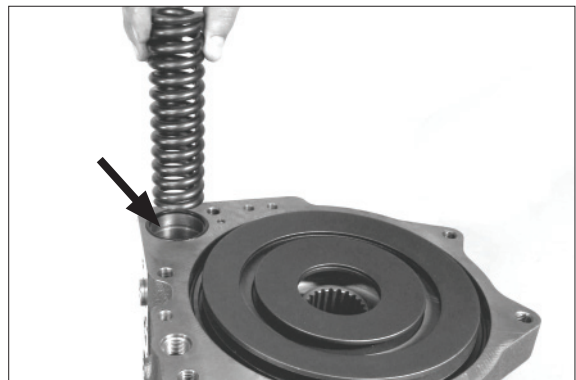

14W7A8TM141

(67) Input housing :

Oil the O-ring and put it into the ring groove of the input housing.

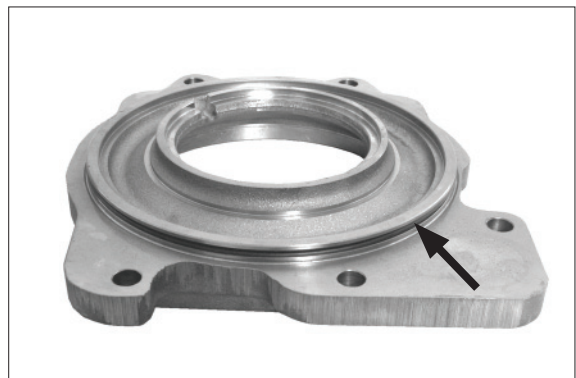

14W7A8TM142

(68) Position the cup springs centrally - assembly aid.

Insert two adjusting screws (M12), mount the input housing and fasten it with hexagon screws.

(S) Adjusting screws (M12) 5870 204 021

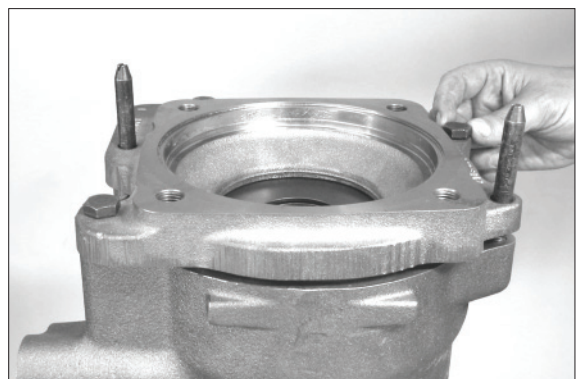

14W7A8TM143

(69) Locate the input housing with hexagon screws equally (risk of breakage) until contact is obtained.

- Tightening torque (M 12/8.8) :
8.2kgf · m (59lbf · ft)

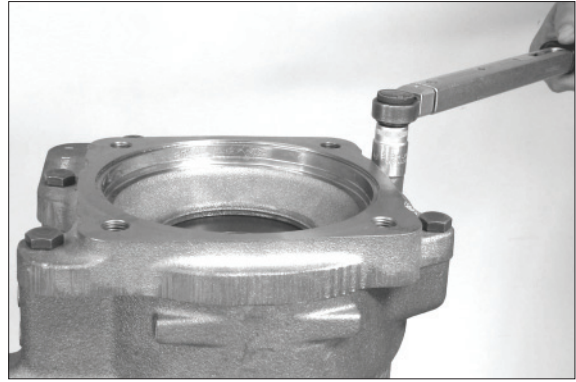

14W7A8TM144

(70) Emergency release (parking brake) :

- 1 = Input housing
- 2 = Housing
- 3 = O-ring
- 4 = Threaded element (orifice)
- 5 = Ball
- 6 = Compression spring
- 7 = O-ring
- 8 = Bleeder
- 9 = Position of lubrication nipple

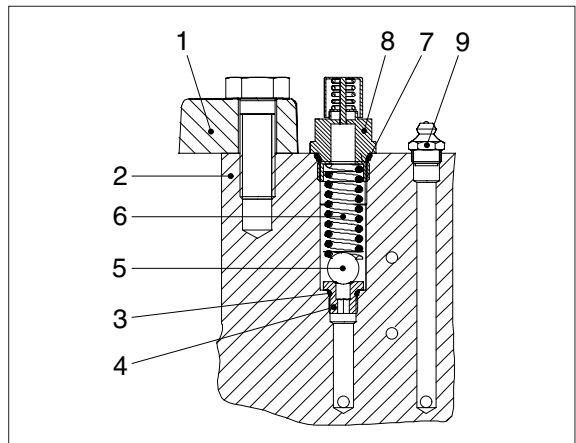

14W7A8TM145

(71) Install the threaded element (4) with O-ring (3).

- Tightening torque (M10 × 1) :
2.45 kgf · m (17.7 lbf · ft)

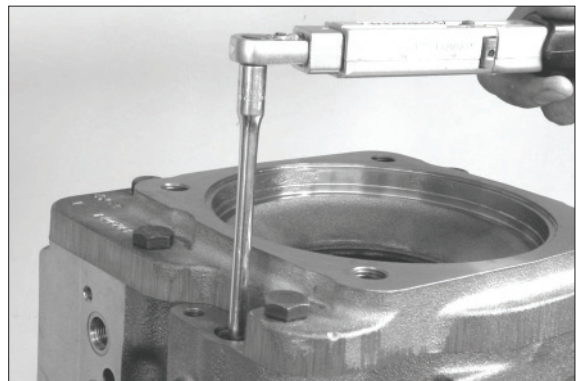

14W7A8TM146

(72) Insert the ball (5).

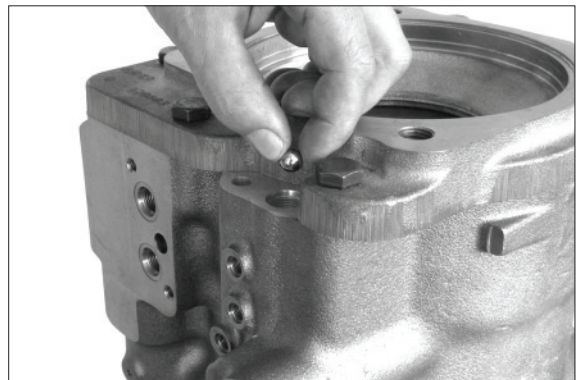

14W7A8TM147

(73) Insert the compression spring (6).

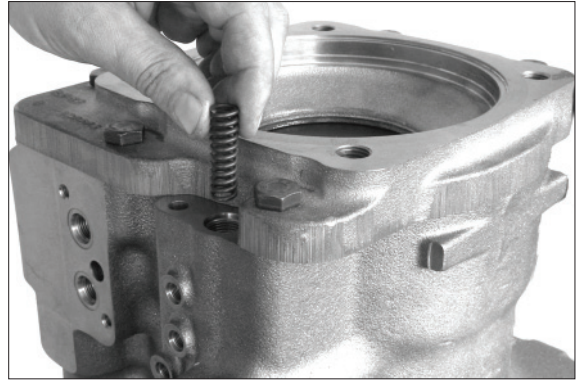

14W7A8TM148

(74) Check the emergency release for leak tightness :

Install both bleeder valves (1), screw plugs (2) with sealing ring and screw plugs (3) with O-ring.

· Tightening torque

Bleeder valve (M10×1) :

2.24 kgf · m (16.2 lbf · ft)

Screw plug (M10×1 with sealing ring) :

1.53 kgf · m (11.1 lbf · ft)

Screw plug (M10×1 with O-ring) :

2.55 kgf · m (18.4 lbf · ft)

1 = Bleeder/pressure-relief valve
(emergency release-park brake)

2 = Screw plug

3 = Bleeder valve
(emergency release-parking brake)

4 = Lubrication nipple
(emergency release-parking brake)

5 = Bleeder valve (multi-disc clutch)

6 = Bleeder valve (multi-disc brake)

7 = Pressure oil connection - Multi-disc brake

8 = Pressure oil connection - Multi-disc clutch

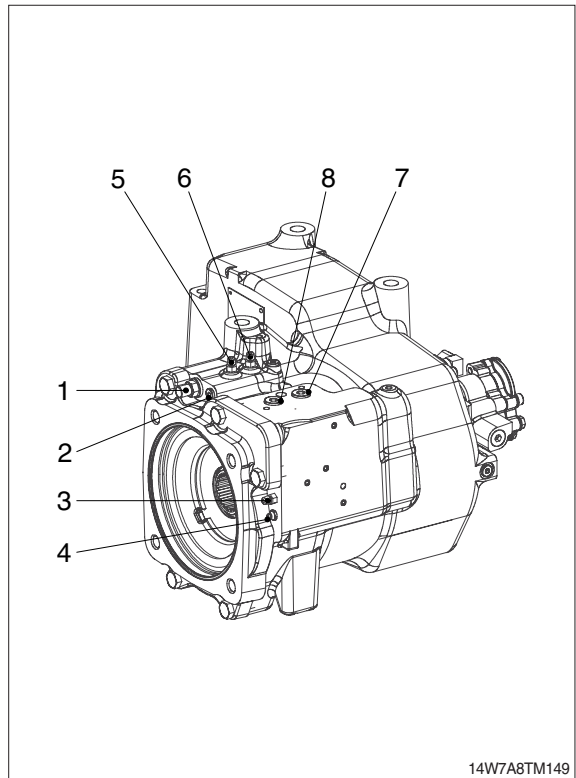

14W7A8TM149

- (75) Install the bleeder valve (1), screw plugs (2) with O-ring screw plug (3) with O-ring and compressed air connection piece (4).

· Tightening torque

Bleeder valve (M10×1) :

2.24 kgf · m (16.2 lbf · ft)

Screw plug (M10×1 with O-ring) :

2.55 kgf · m (18.4 lbf · ft)

Screw plug (M18×1.5 with O-ring) :

3.57 kgf · m (25.8 lbf · ft)

Compr. air connect. piece (M10×1 w/seal ring) :

1.53 kgf · m (11.1 lbf · ft)

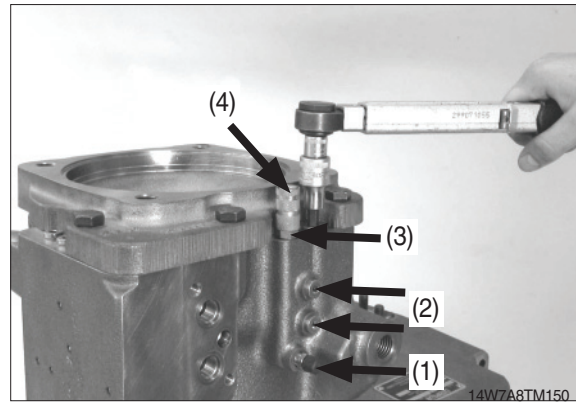

- (76) Pressurize the emergency release with compressed air $P = 5 + 1$ bar and close the shut-off valve.

During a test duration of 3 minutes no pressure drop is allowed!

(S) Air connection 5870 505 012

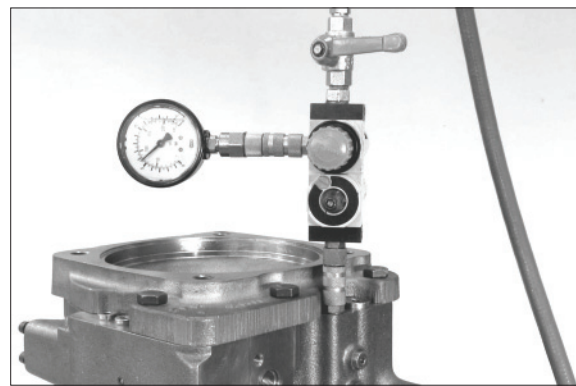

14W7A8TM151

- (77) Multi-disc brake :

Connect the HP-pump (AB - see figure TM149.

Build up a pressure of $P = 30$ max. 35 bar
- Bleed the pressure chamber (several times). Close the shut off valve.

During a test duration of 3 minutes no measurable pressure drop is allowed.

(S) HP-pump 5870 287 007



14W7A8TM152

(78) Closing pressure test (Cup spring preloading force) :

- ※ When measuring the closing pressure the valve block is not allowed to be attached to the transmission due to the by-pass function between brake and clutch.

Connection AK (see figure TM149 re-spectively) open (not closed and tank connection respectively).

Reduce the pressure slowly, when pressure range 11.2~9.2 kgf/cm² (closing pressure) is reached, the input shaft has to be locked at a tightening torque of 5.1 kgf · m (36.9 lbf · ft).

- (S) Spline mandrel 5870 510 039
- (S) Torque spanner 5870 203 037

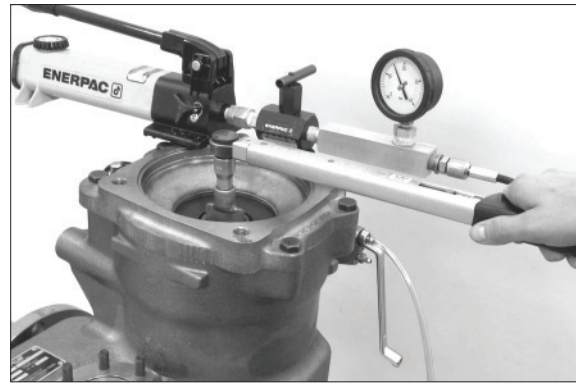

14W7A8TM153

(79) Multi-disc clutch :

Connect the HP-pump (AK-see figure TM149),

Build up a pressure of P = 30.6~35.7 kgf/cm²

-Bleed the pressure chamber (several times). Close the shut-off valve.

During a test duration of 3 minutes no measurable pressure drop is allowed.

- (S) HP-pump 5870 287 007

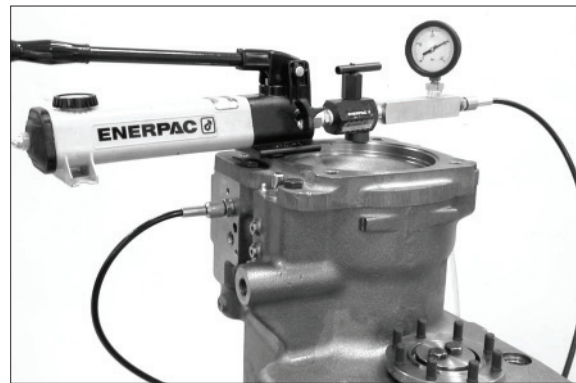

14W7A8TM154

(80) Closing pressure test (cup spring preloading force) :

When measuring the closing pressure the valve block (only for the version with mounted electric downshift interlock) is not allowed to be attached to the transmission due to the by-pass function between brake and clutch.

Connection AB (see figure TM149 re-spectively) open (not closed and tank connection respectively).

Reduce the pressure slowly, when pressure range 15.8~13.8 kgf/cm² (closing pressure) is reached, the input shaft has to be locked at a tightening torque of 5.1 kgf · m (36.9 lbf · ft).

- (S) Spline mandrel 5870 510 039

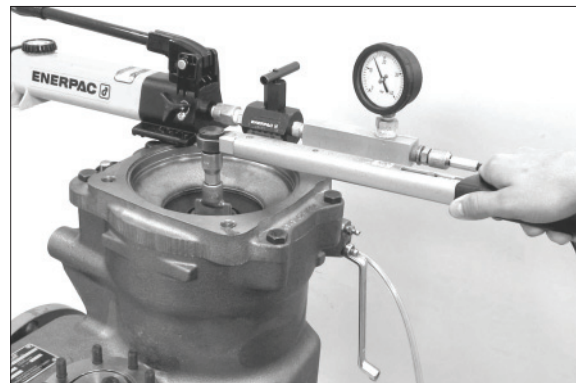

14W7A8TM155

(81) Speed transmitter :

Install the speed transmitter with O-ring.

- Tightening torque (M8 × 8.8) :
2.35kgf · m (17.0lbf · ft)

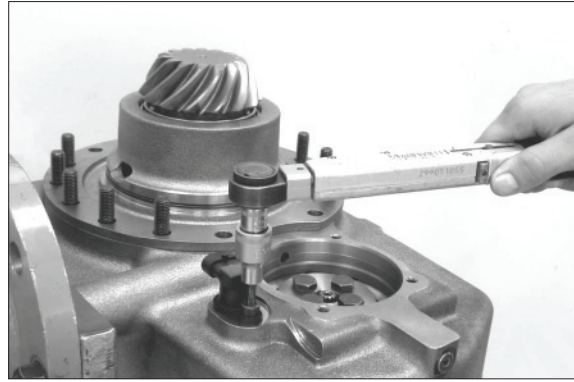

14W7A8TM156

(82) Lube oil pump/downshift inter-lock :

Install the lube oil pump (with O-rings) or the downshift interlock depending on the version.

Cpl. assembly of the lube oil pump/
downshift interlock - see figure
TM171~TM195.

- Tightening torque (M8 × 8.8) :
2.35kgf · m (17.0lbf · ft)

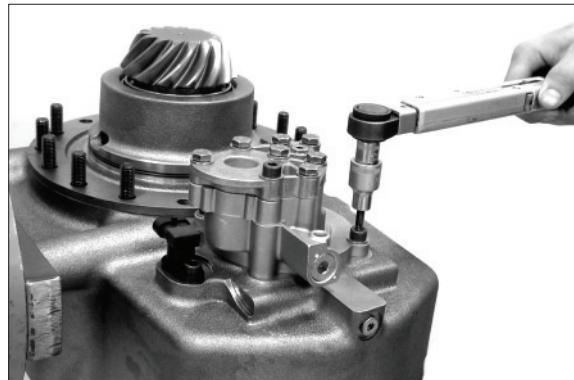

14W7A8TM157

5) DISASSEMBLY DOWNSHIFT INTERLOCK

Hydraulic downshift interlock :

(1) Disassemble both oil tubes.

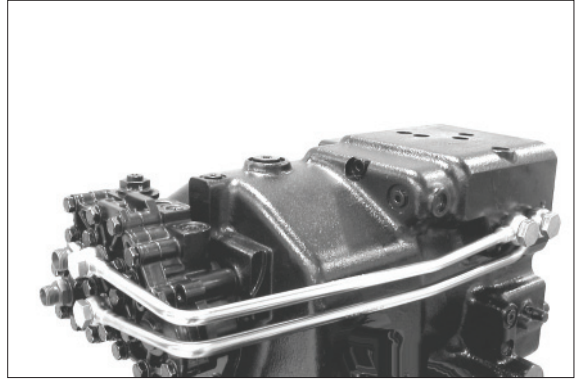

14W7A8TM158

(2) Loosen the bolt connection of the shift interlock (3 × cap screws) and remove the cpl. shift interlock.

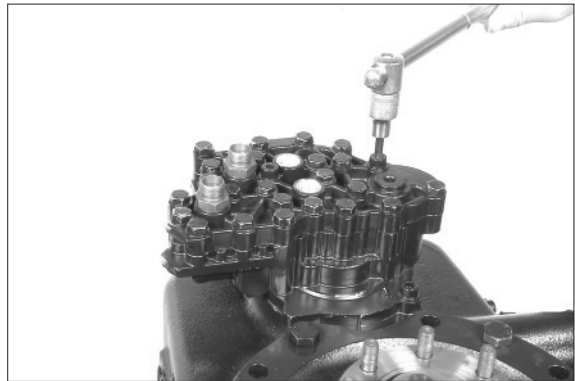

14W7A8TM159

(3) Loosen the cover bolt connection, remove the cover and flat gasket (also see figure TM161).



14W7A8TM160

(4) Take the filter out of the housing.

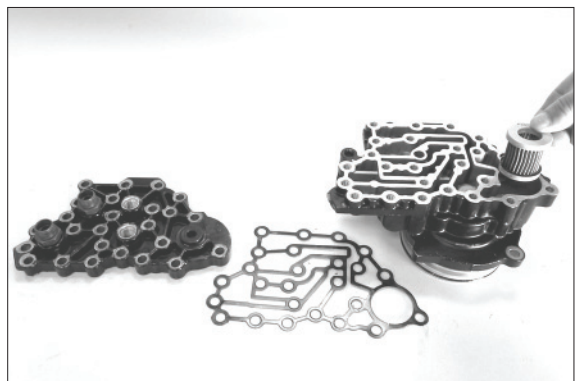

14W7A8TM161

(5) Loosen pump cover bolt connection.



14W7A8TM162

(6) Keep pump to contact and rotate it by 180°- disassembly aid!

Then pull the pump in vertical position out of the housing pay attention to possibly released balls/compression springs (see figure TM164 and TM165).

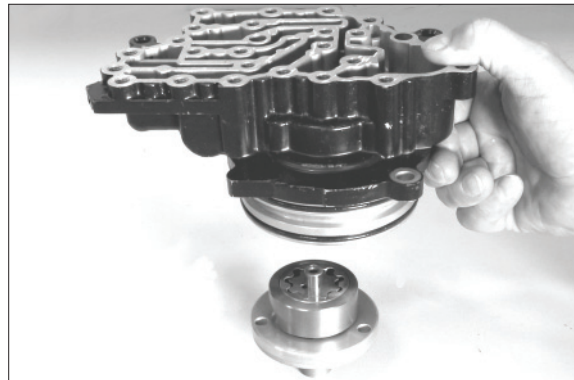

14W7A8TM163

(7) Remove the outer (1) and internal rotor (2) and take the released ball [(3) driver] out of the control housing (4).

Outer, internal rotor and control housing = rotor set.

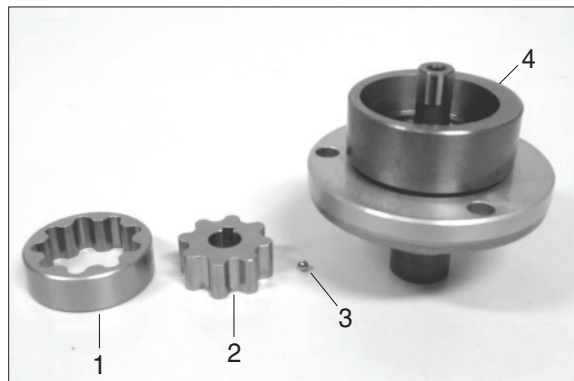

14W7A8TM164

(8) Remove the control housing and the released balls and compression springs (3 pcs. each).

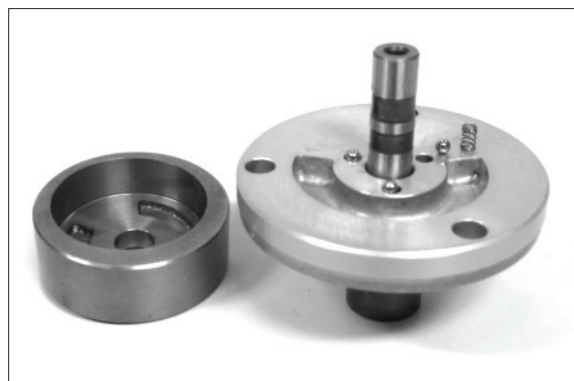

14W7A8TM165

(9) Unsnap the retaining ring.

(S) Set of internal pliers 5870 900 014

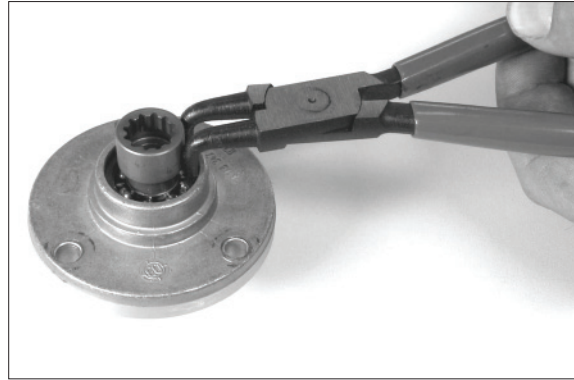

14W7A8TM166

(10) Pull the cpl. pump shaft out of the pump cover.

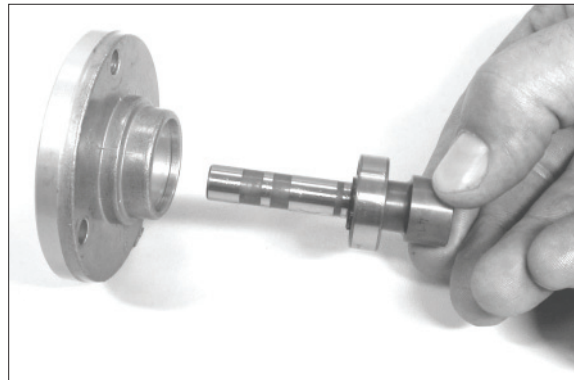

14W7A8TM167

(11) Unsnap the retaining ring and press the ball bearing from the shaft.

(S) Set of external pliers 5870 900 016



14W7A8TM168

(12) Pull the needle sleeve out of the housing bore.

(S) Internal extractor 5870 300 012

(S) Counter support 5870 300 011



14W7A8TM169

- (13) 1 = Housing
- 2 = O-ring
- 3 = Check valve (010)
- 4 = Gear shift piston
- 5 = Check valve (009)
- 6 = Check valve (008)
- 7 = Pressure limiting valve

Remove the O-rings and all single parts/valves.

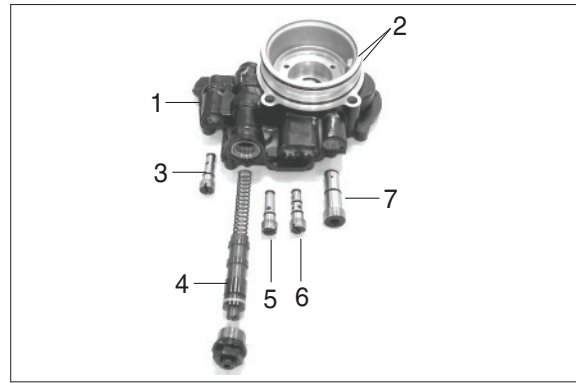

14W7A8TM170

6) REASSEMBLY DOWNSHIFT INTERLOCK

- (1) 1 = Housing
- 2 = Gear shift piston
- 3 = Pressure limiting valve
- 4 = Check valve (008)
- 5 = Check valve (009)
- 6 = Check valve (010)
- 7 = Filter
- 8 = Lube oil pump

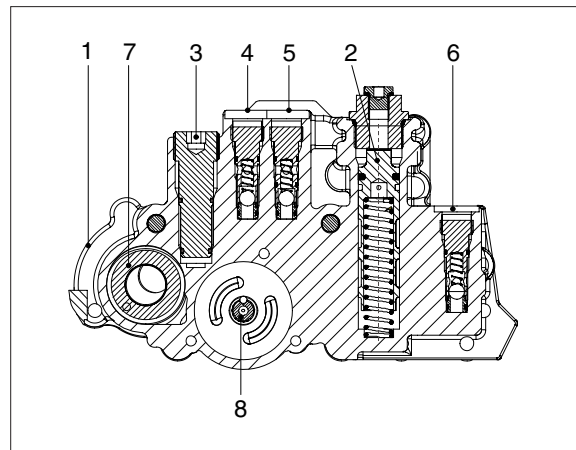

14W7A8TM171

- (2) Install the gasket (consisting of plastic and O-ring - figure TM172 and TM173). Put the O-ring (see arrow) into the ring groove of the piston. Lead the plastic ring by means of the mounting bush (S) over the piston and position it at the O-ring.

(S) Mounting bush 5870 651 055

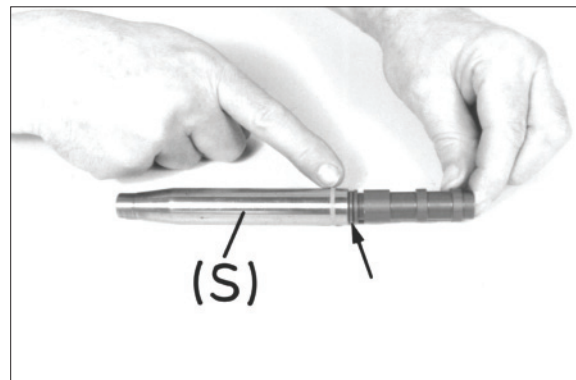

14W7A8TM172

- (3) Calibrate the plastic ring by means of the bush.

(S) Calibrating pin 5870 651 056



14W7A8TM173

- (4) Insert the compression spring, oil and mount the preassembled piston.

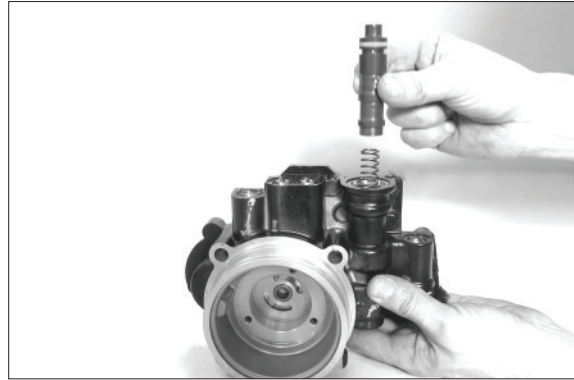

14W7A8TM174

- (5) Fix the piston with screw plug (1-with O-ring). Install the screw plug (2-with sealing ring).

· Tightening torque :

Screw plug (M24 × 1.5) : 5.1 kgf · m (36.9 lbf · ft)

Screw plug (M10 × 1) : 1.53 kgf · m (11.1 lbf · ft)

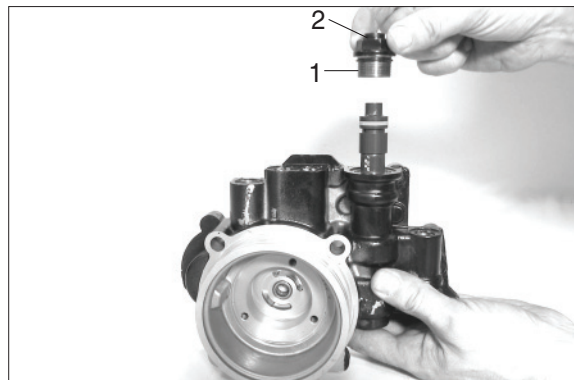

14W7A8TM175

- (6) Install the single parts according to the illustration on the left.

※ Observe the installation position of the different check valves!

Oil the single parts.

1 = Pressure limiting valve (cpl.) :

1.0 kgf · m (7.2 lbf · ft)

2 = Check valve (cpl.) 4143 242 008

1.0 kgf · m (7.2 lbf · ft)

3 = Check valve (cpl.) 4143 242 009

1.0 kgf · m (7.2 lbf · ft)

4 = Check valve (cpl.) 4143 242 010

1.0 kgf · m (7.2 lbf · ft)

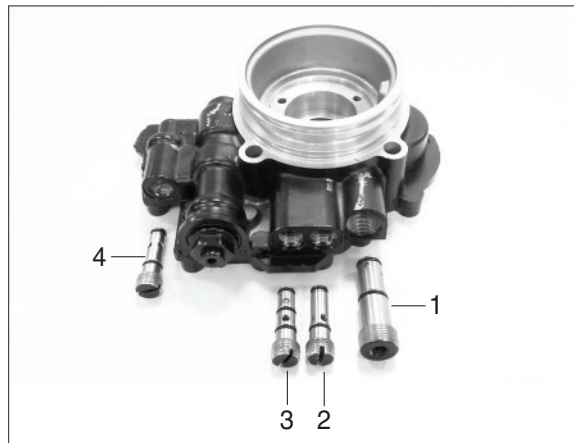

14W7A8TM176

- (7) Secure the check valves and the pressure limiting valve by two blows each with the center punch.

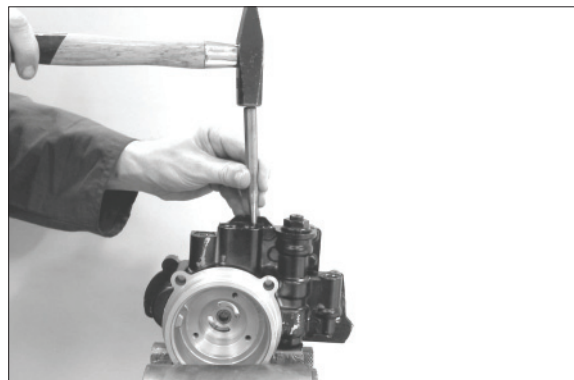

14W7A8TM177

(8) Check passage of the orifice/oil bore in the housing bottom!

※ Insert the needle sleeve to installation dimension X.

X = 0.2~0.7 mm below plane face/housing

※ The exact installation position is ensured by use of the specified mounting tool!

(S) Mounting tool 5870 705 003

※ Insert the needle sleeve with marked face showing upwards!

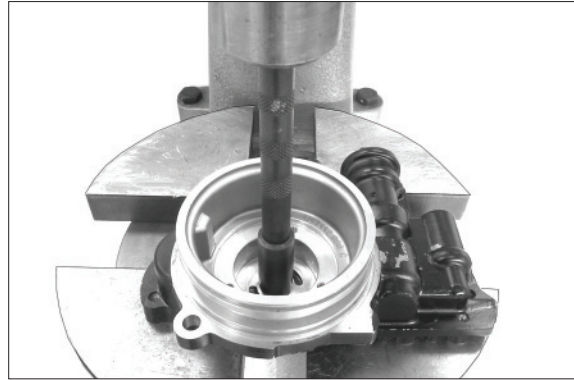

14W7A8TM178

(9) Mount the ball bearing onto the shaft and fasten it with the retaining ring.

(S) Set of external pliers 5870 900 016



14W7A8TM179

(10) Press the preassembled pump shaft into the pump cover and fasten it with the retaining ring.

(S) Set of internal pliers 5870 900 014



14W7A8TM180

(11) Insert the compression springs (1) and ball (2) into bores (see arrows 3x).

※ Prior to installation oil single parts of the pump/rotor set (control housing, internal and outer rotor) use apply oil.

※ Keep the pump shaft/cover in vertical position-pay attention to the position of the inserted balls/compression springs-see steps figure TM 181~TM186.

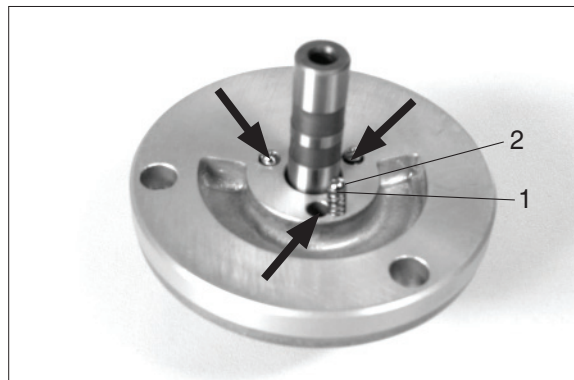

14W7A8TM181

- (12) Mount the control housing.
Control housing / internal and outer rotor.

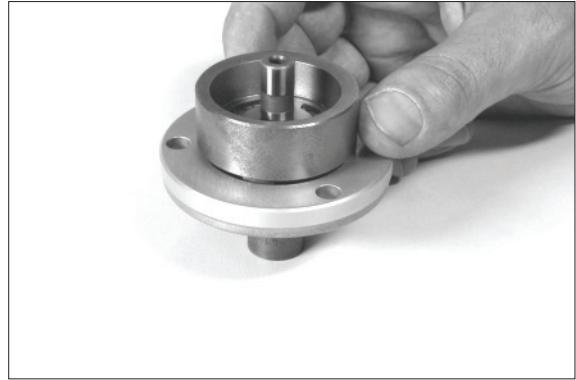

14W7A8TM182

- (13) Position the ball - see arrow (drive for internal rotor) with grease (assembly aid) into the recess of the pump shaft.

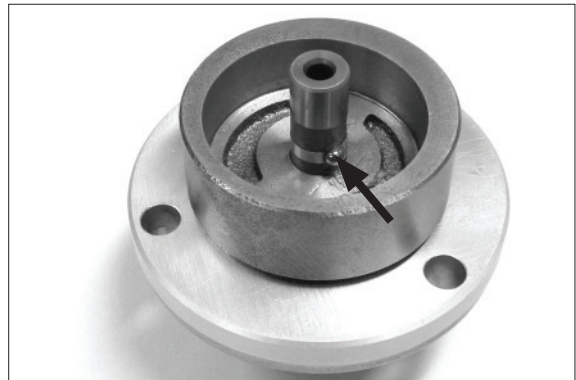

14W7A8TM183

- (14) Mount the internal rotor.
Place the groove of the internal rotor over the driving ball (see arrows).



14W7A8TM184

- (15) Assemble the outer rotor.

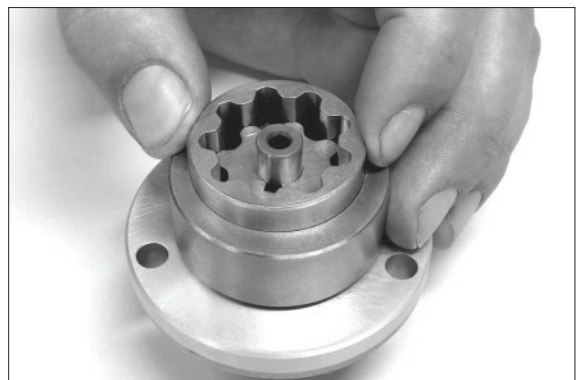

14W7A8TM185

- (16) Keep the preassembled pump in vertical position (see instruction figure TM 181) and put on the housing.

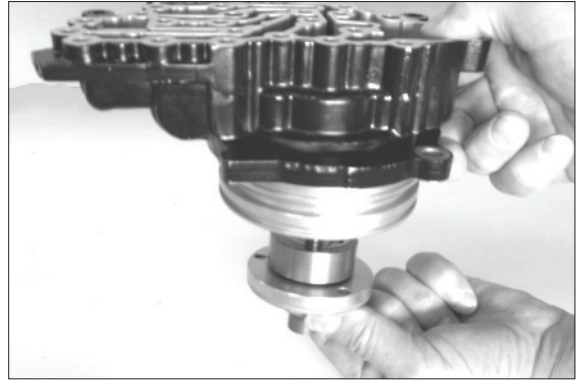

14W7A8TM186

- (17) Keep the assembled pump to contact and rotate the housing by 180°.

Fasten the pump with hexagon screws.

- Tightening torque (M6 × 8.8) :

1.0kgf · m (7.2lbf · ft)



14W7A8TM187

- (18) Insert the screen filter - Observe the installation position.

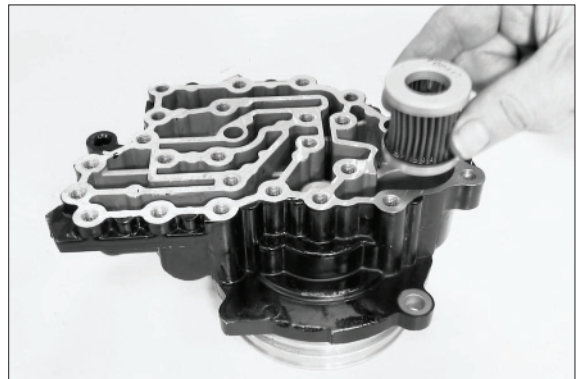

14W7A8TM188

- (19) Place the gasket.

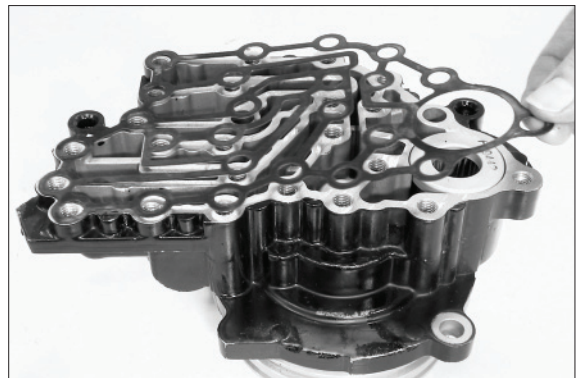

14W7A8TM189

(20) Position the cover, fasten it with hexagon screws and washers.

Pay attention to different screw length!

- Tightening torque (M8 × 10.9) :
2.35 kgf · m (17.0 lbf · ft)

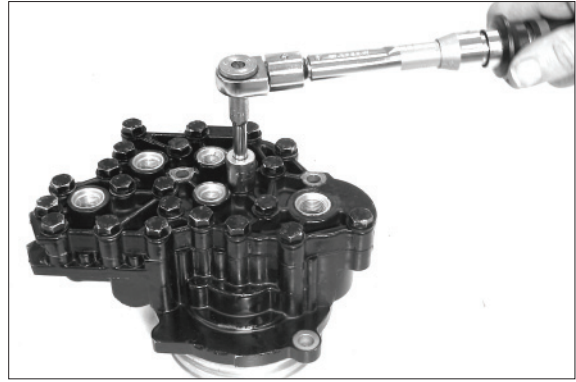

14W7A8TM190

(21) Oil both O-rings (arrows) and put them into the ring grooves of the housing.

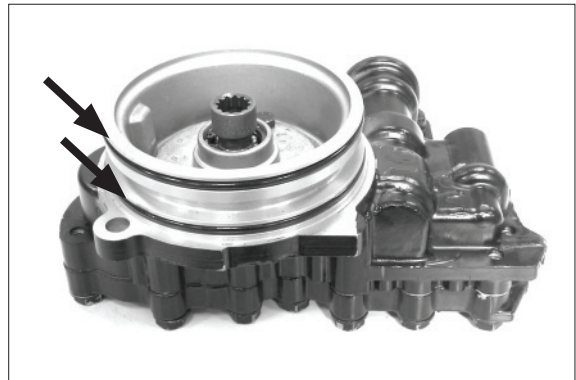

14W7A8TM191

(22) Mount the preassembled downshift interlock and fasten with cap screws and washers.

Pay attention to different screw length!

- Tightening torque (M8 × 10.9) :
2.35kgf · m (17.0lbf · ft)

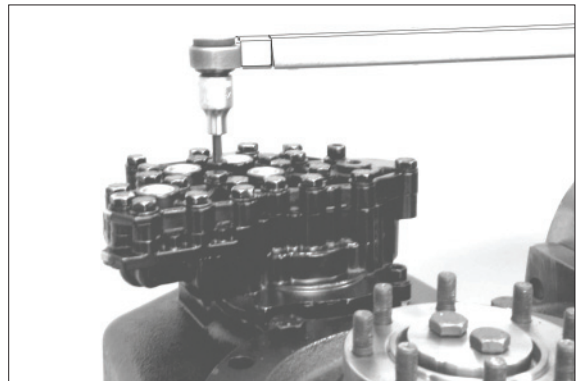

14W7A8TM192

(23) Install both screw-in sleeves and the screw plug (see arrows) with O-rings.

- Tightening torque :
Screw-in sleeve (M16 × 1.5) :
2.35 kgf · m (17.0 lbf · ft)
Screw plug (M18 × 1.5) :
3.6 kgf · m (26.0lbf · ft)

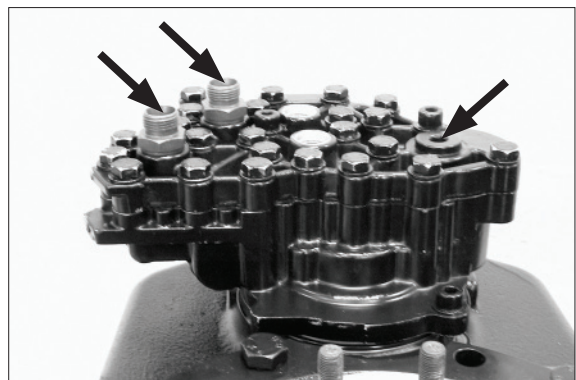

14W7A8TM193

- (24) 1 = Oil tube
2 = Union screw (M16 × 1.5)
3 = Sealing ring
4 = Union screw (M14 × 1.5)
5 = Sealing ring

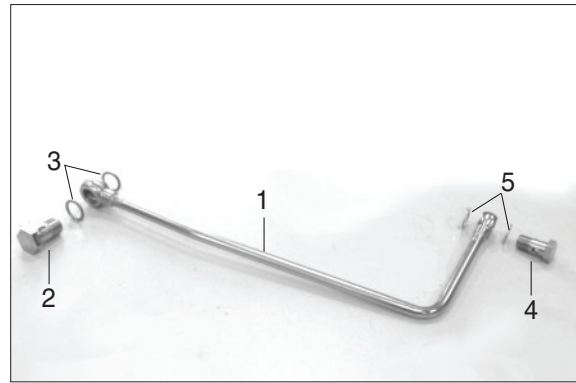

14W7A8TM194

(25) Install both oil tubes.

- Tightening torque :
Union screw (M14 × 1.5) :
2.55kgf · m (18.4lb · ft)
Union screw (M16 × 1.5) :
4.6kgf · m (33.2lb · ft)

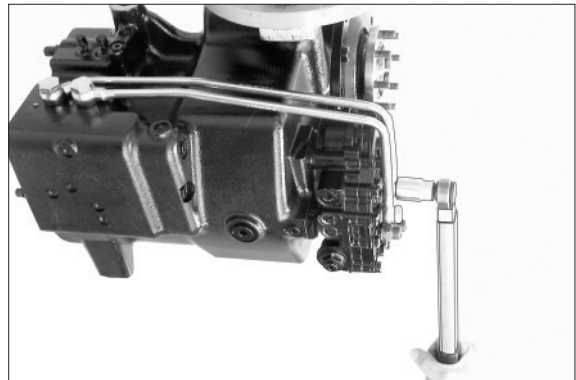

14W7A8TM195