

GROUP 14 WORK EQUIPMENT

1. STRUCTURE

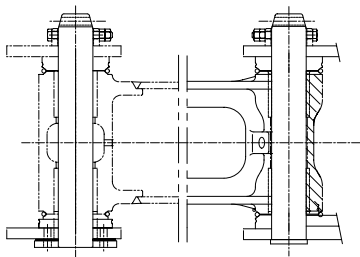

SECTION A

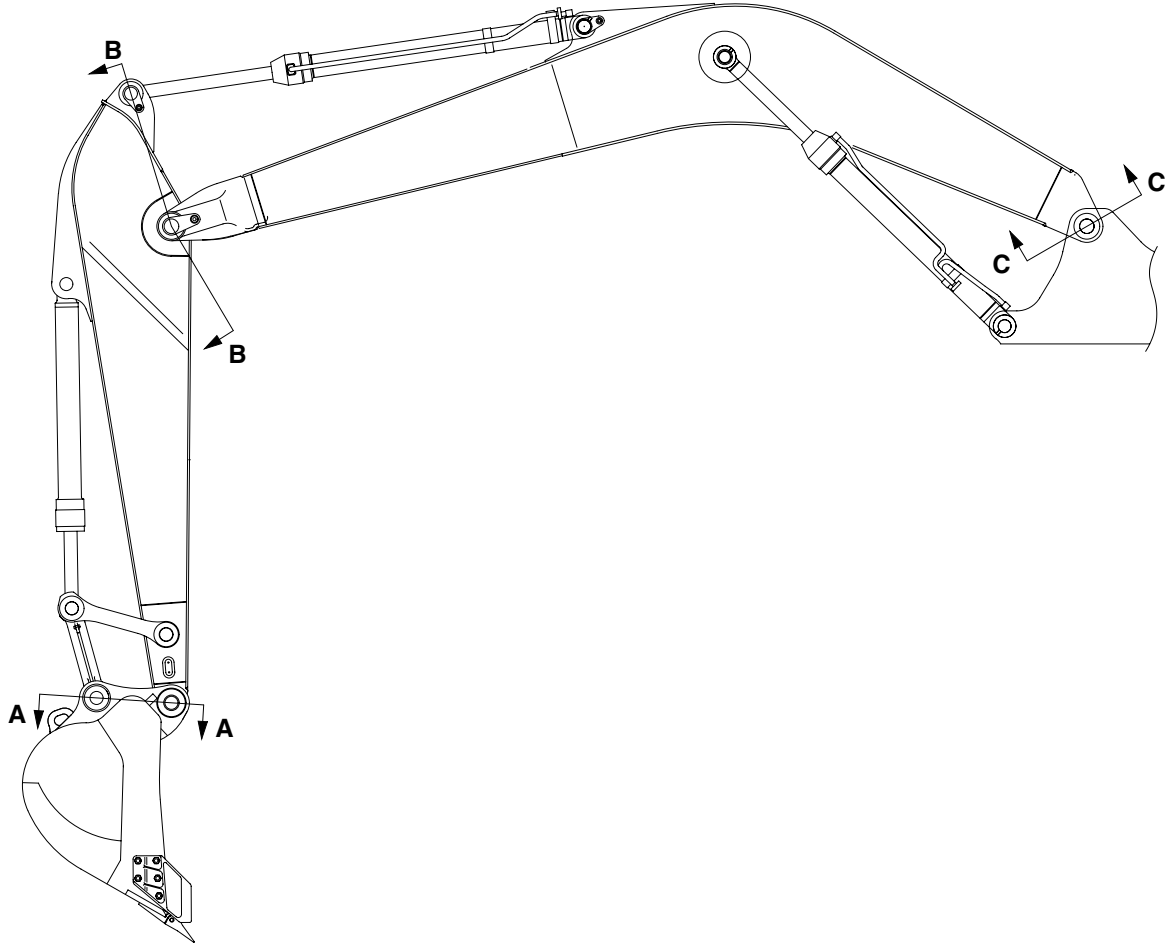
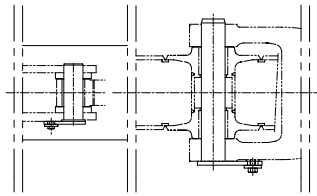

SECTION B

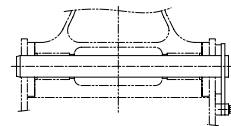

SECTION C

21078DA44

2. REMOVAL AND INSTALL

1) BUCKET ASSEMBLY

(1) Removal

- ① Lower the work equipment completely to ground with back of bucket facing down.

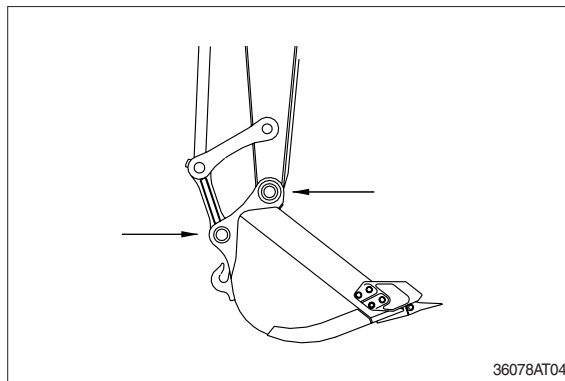

- ② Remove nut (1), bolt (2) and draw out the pin (B).

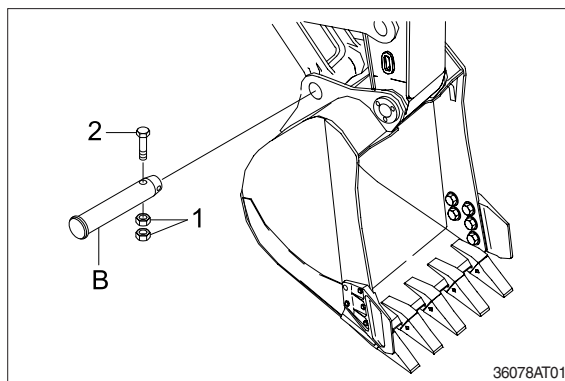

- ③ Remove nut (3), bolt (4) and draw out the pin (A) then remove the bucket assembly.
· Weight : 540 kg (1190 lb)

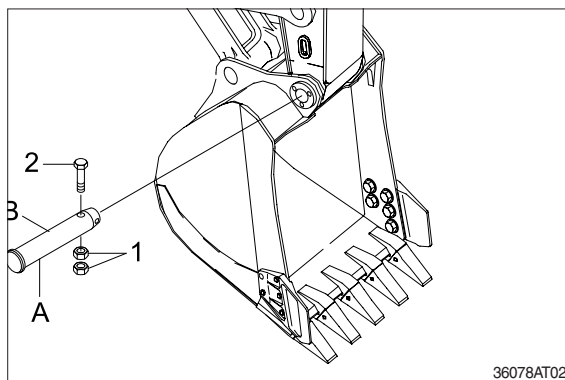

(2) Install

- ① Carry out installation in the reverse order to removal.

▲ When aligning the mounting position of the pin, do not insert your fingers in the pin hole.

- ※ Adjust the bucket clearance.
For detail, see operation manual.

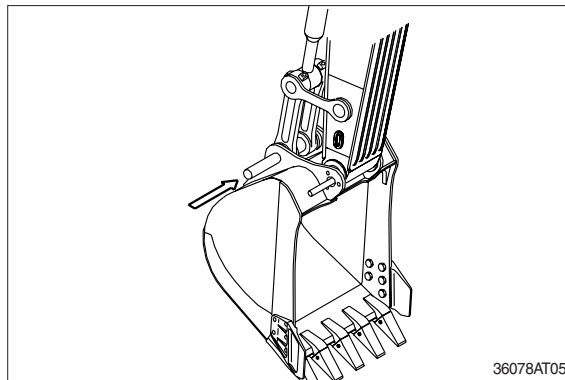

2) ARM ASSEMBLY

(1) Removal

※ Loosen the breather slowly to release the pressure inside the hydraulic tank.

▲ Escaping fluid under pressure can penetrate the skin causing serious injury.

① Remove bucket assembly.

For details, see removal of bucket assembly.

② Disconnect bucket cylinder hose (1).

▲ Fit blind plugs (5) in the piping at the chassis end securely to prevent oil from spurting out when the engine is started.

③ Sling arm cylinder assembly, remove spring, pin stopper and pull out pin.

※ Tie the rod with wire to prevent it from coming out.

④ For details, see removal of arm cylinder assembly.

Place a wooden block under the cylinder and bring the cylinder down to it.

⑤ Remove bolt (2), plate (3) and pull out the pin (4) then remove the arm assembly.

※ · Weight : 540 kg (1190 lb)

When lifting the arm assembly, always lift the center of gravity.

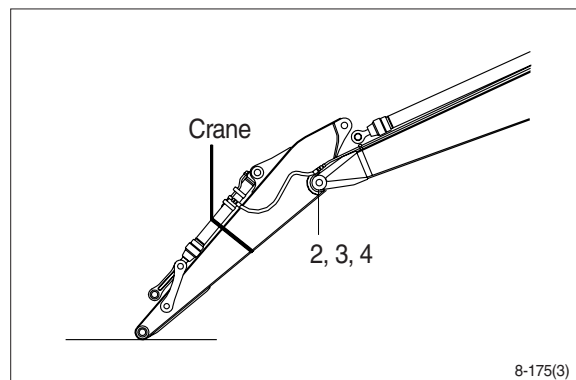
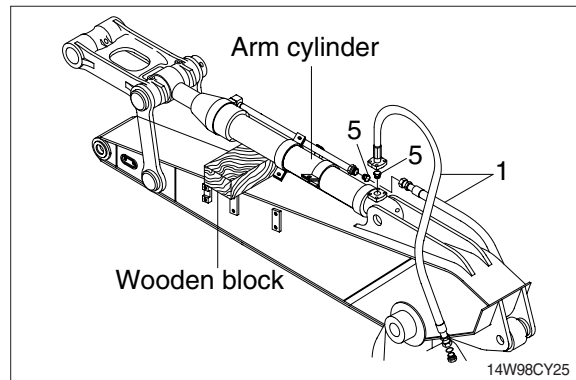
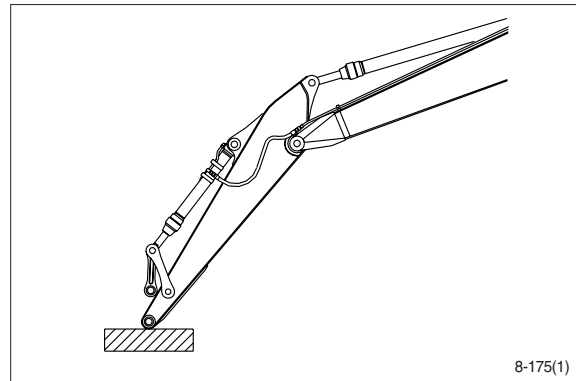

(2) Install

① Carry out installation in the reverse order to removal.

▲ When lifting the arm assembly, always lift the center of gravity.

※ Bleed the air from the cylinder.

3) BOOM CYLINDER

(1) Removal

- ① Remove arm and bucket assembly.
For details, see removal of arm and bucket assembly.
- ② Remove boom cylinder assembly from boom.
For details, see removal of arm cylinder assembly.

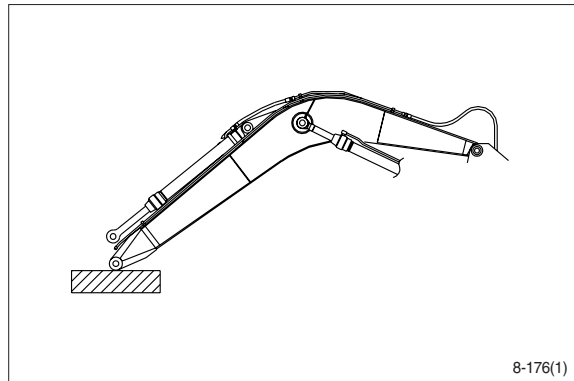

- ③ Disconnect head lamp wiring.
- ④ Disconnect bucket cylinder hose (2) and arm cylinder hose (1).
- ※ When the hose are disconnected, oil may spurt out.
- ⑤ Sling boom assembly (3).

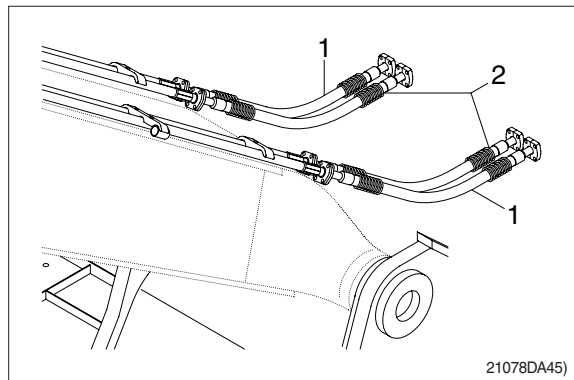

- ⑥ Remove bolt (4), plate (5) and pull out the pin (6) then remove boom assembly.
· Weight :1050 kg (2310 lb)
- ※ When lifting the boom assembly always lift the center of gravity.

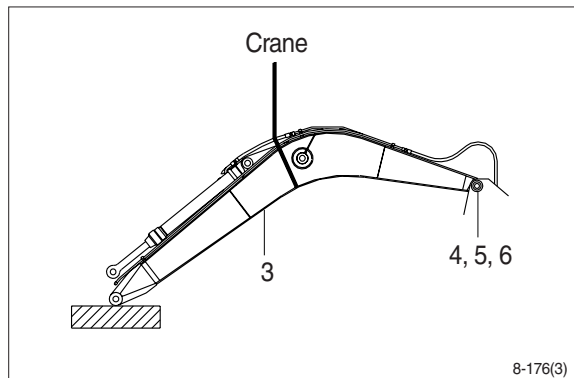

(2) Install

- ① Carry out installation in the reverse order to removal.

▲ When lifting the arm assembly, always lift the center of gravity.

- ※ Bleed the air from the cylinder.

