

## GROUP 3 ELECTRICAL SYSTEM

### 1. WHEN STARTING SWITCH IS TURNED ON, MONITOR PANEL DISPLAY DOES NOT APPEAR

- Before disconnecting the connector, always turn the starting switch OFF.
- Before carrying out below procedure, check all the related connectors are properly inserted and short of fuse No.7, 11.
- After checking, insert the disconnected connectors again immediately unless otherwise specified.

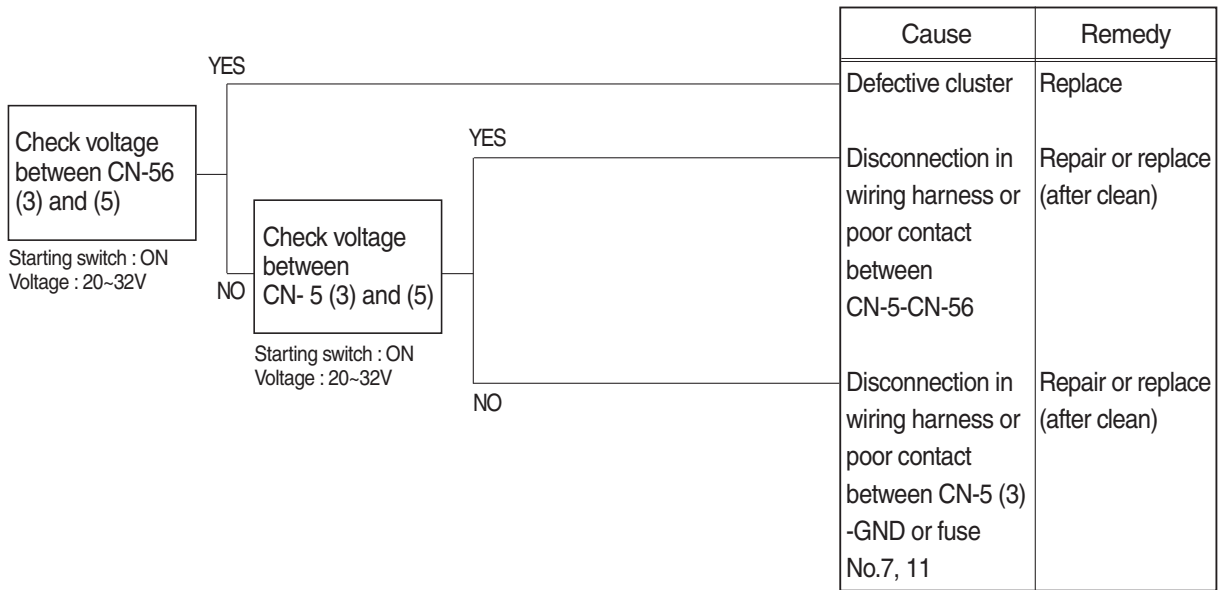

#### Check voltage

YES	20~32V
NO	0V

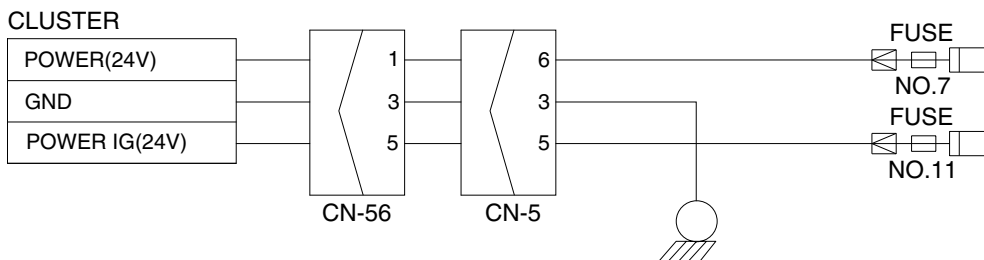

14W96ES01

## 2. COMMUNICATION ERROR FLASHES ON THE CLUSTER (HCESPN 840, FMI 2)

- Before disconnecting the connector, always turn the starting switch OFF.
- Before carrying out below procedure, check all the related connectors are properly inserted.
- After checking, insert the disconnected connectors again immediately unless otherwise specified.

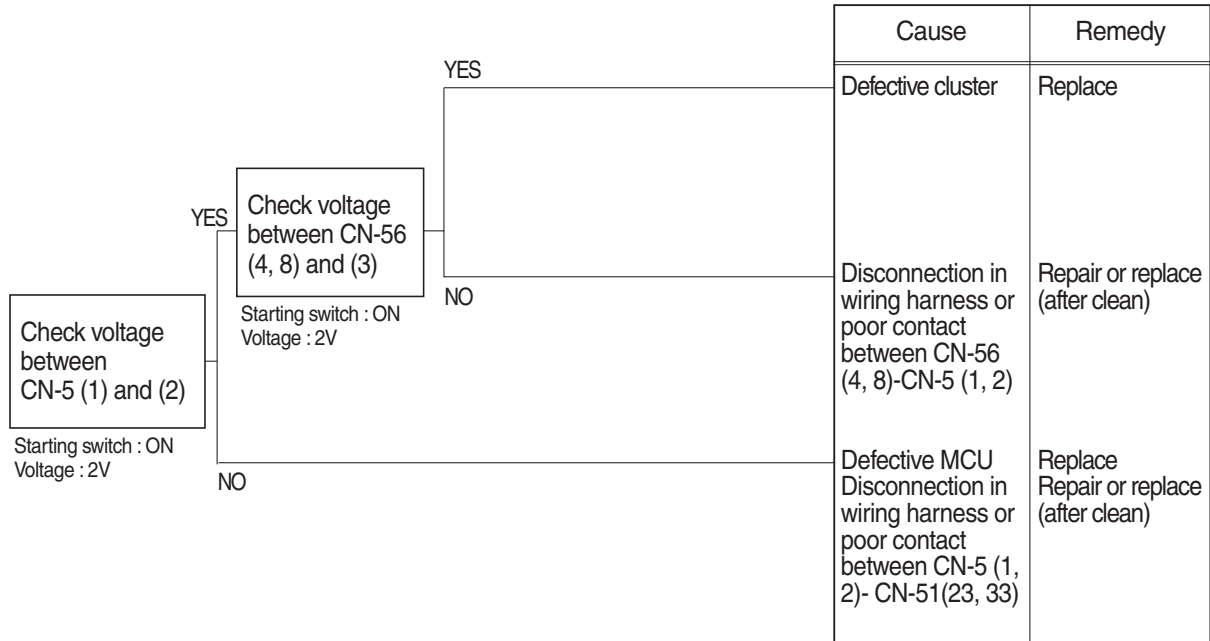

### Check voltage

YES	2V
NO	0V

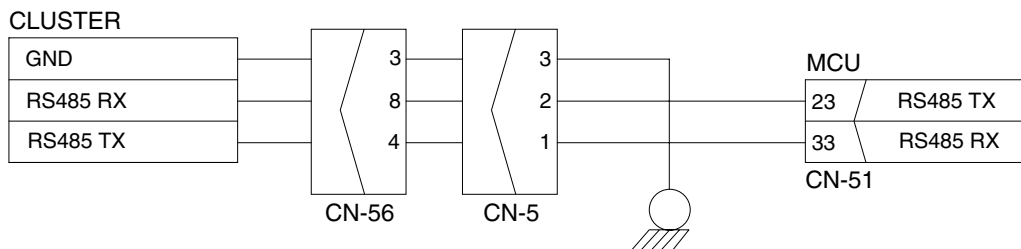

14W96ES02

### 3. BATTERY CHARGING WARNING LAMP LIGHTS UP (Starting switch : ON)

- Before disconnecting the connector, always turn the starting switch OFF.
- Before carrying out below procedure, check all the related connectors are properly inserted.
- After checking, insert the disconnected connectors again immediately unless otherwise specified.

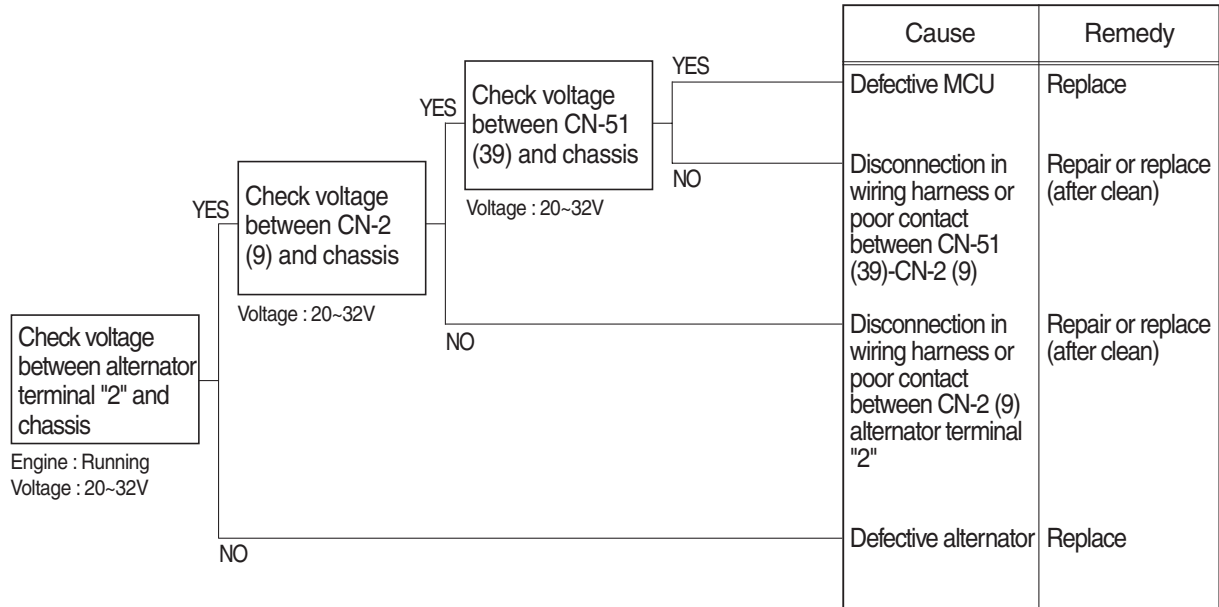

#### Check voltage

YES	20~32V
NO	0V

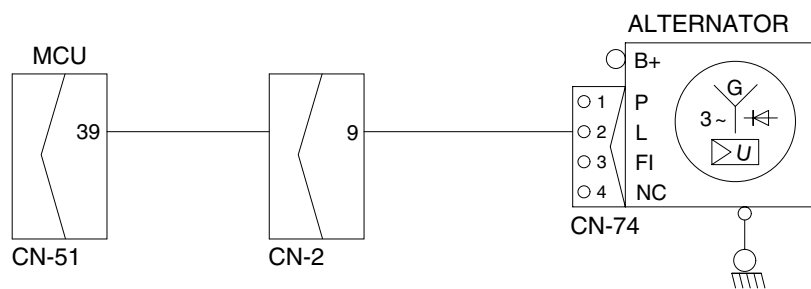

17W96ES03

#### 4. WHEN COOLANT OVERHEAT WARNING LAMP LIGHTS UP (engine is started)

- Before disconnecting the connector, always turn the starting switch OFF.
- Before carrying out below procedure, check all the related connectors are properly inserted.
- After checking, insert the disconnected connectors again immediately unless otherwise specified.

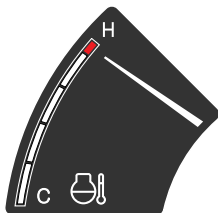
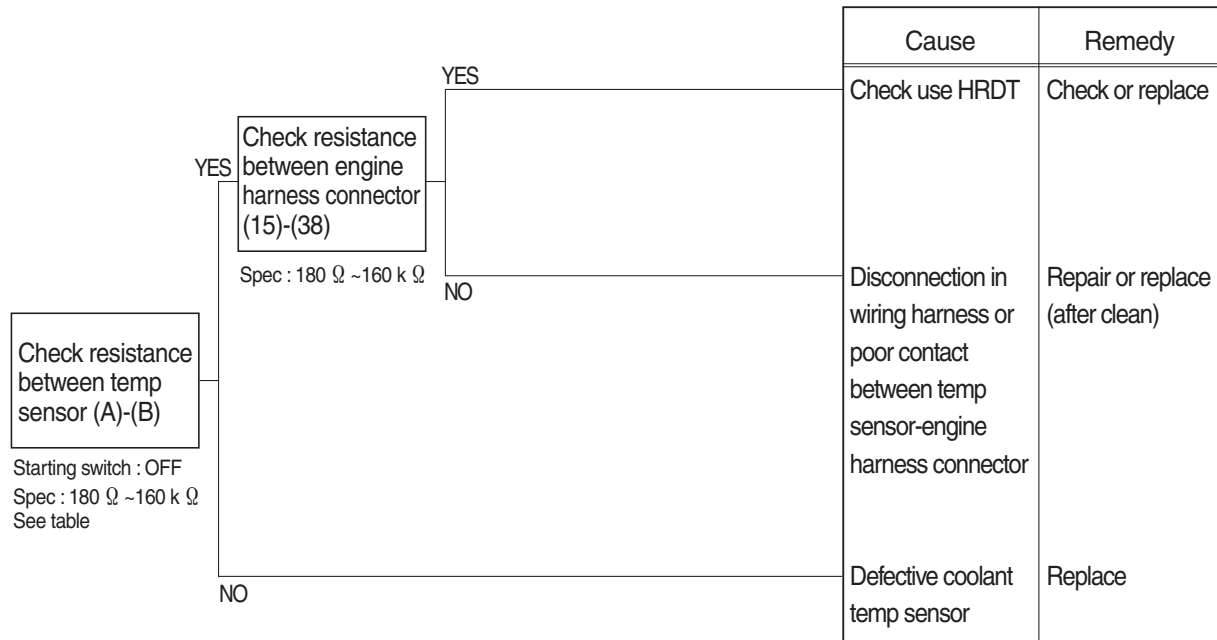

Check Table

Temperature (°C)	0	25	50	80	95
Resistance (k Ω)	30~37	9.3~10.7	3.2~3.8	1.0~1.3	0.7~0.8

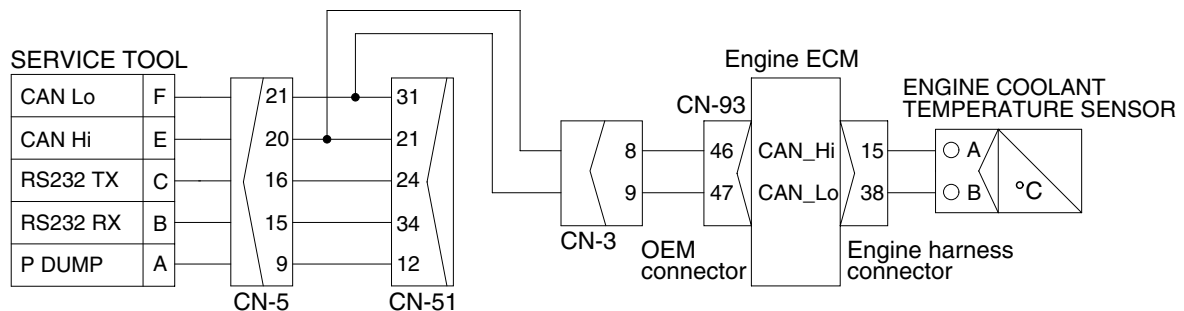

21096ES04

5.  **WHEN AIR CLEANER WARNING LAMP LIGHTS UP** (engine is started)

- Before disconnecting the connector, always turn the starting switch OFF.
- Before carrying out below procedure, check all the related connectors are properly inserted.
- After checking, insert the disconnected connectors again immediately unless otherwise specified.

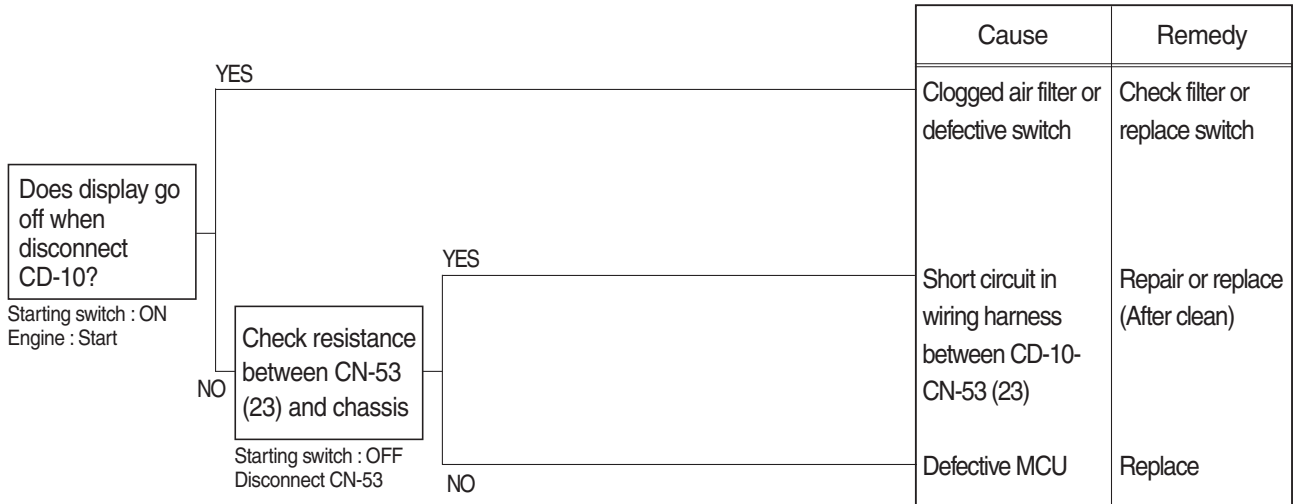

**Check resistance**

YES	MAX 1Ω
NO	MIN 1MΩ

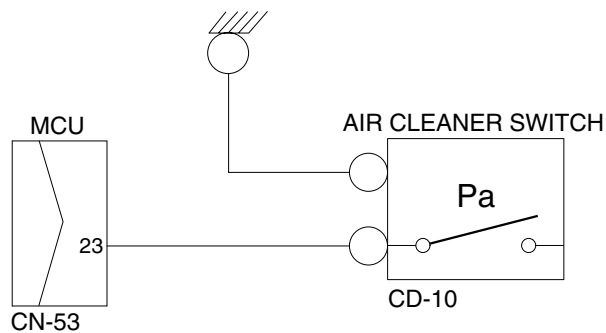

21096ES05

## 6. WHEN ENGINE OIL PRESSURE WARNING LAMP LIGHTS UP (engine is started)

- Before disconnecting the connector, always turn the starting switch OFF.
- Before carrying out below procedure, check all the related connectors are properly inserted.
- After checking, insert the disconnected connectors again immediately unless otherwise specified.

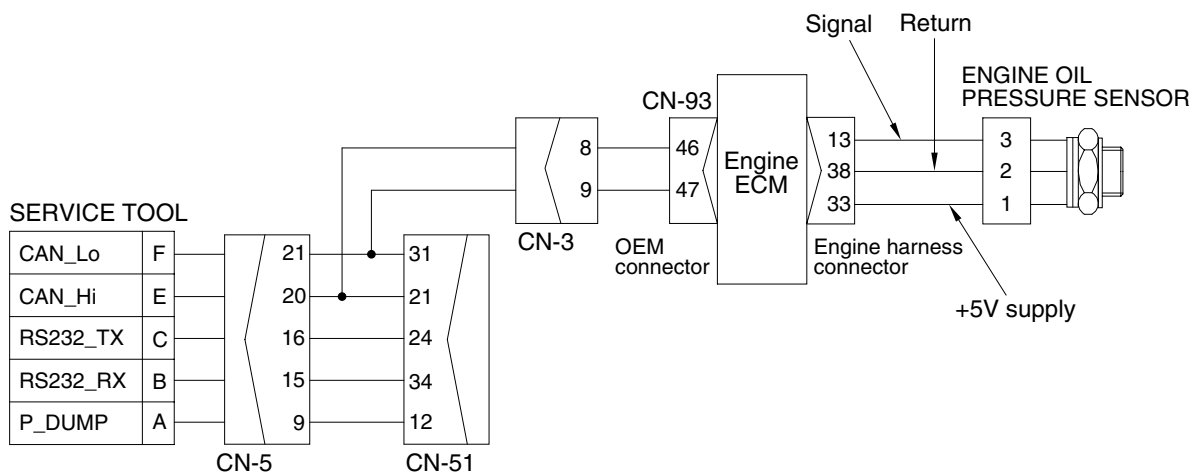
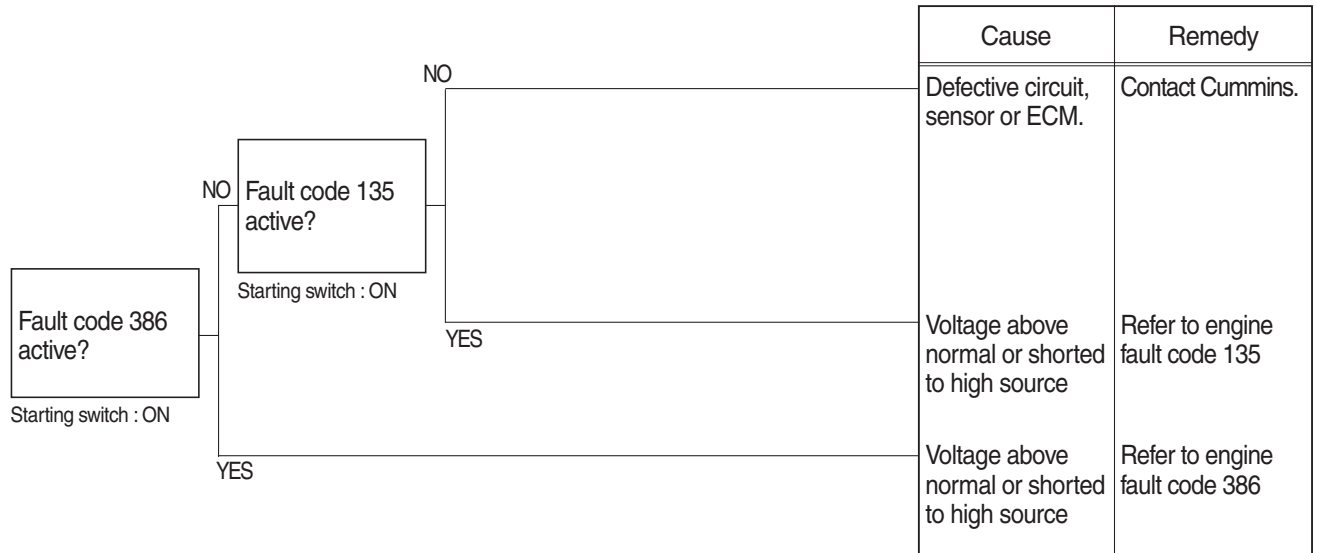

21096ES06

## 7. WHEN HYDRAULIC OIL TEMPERATURE WARNING LAMP LIGHTS UP (engine is started)

- Before disconnecting the connector, always turn the starting switch OFF.
- Before carrying out below procedure, check all the related connectors are properly inserted.
- After checking, insert the disconnected connectors again immediately unless otherwise specified.

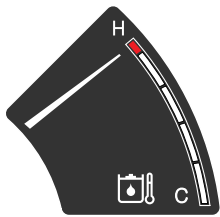
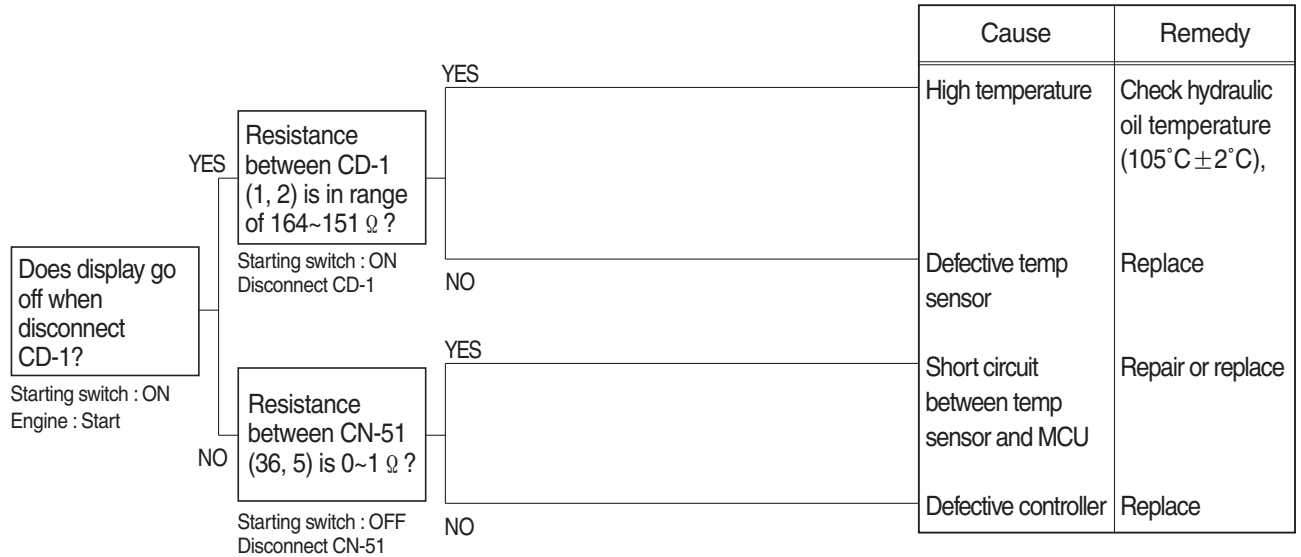

Check Table

Temperature ( $^{\circ}\text{C}$ )	~ -30	~ -10	~ 0	~ 40	~ 70	~ 80	~ 90	~ 100	105~
Resistance (k $\Omega$ )	22.22 ~31.78	8.16 ~10.74	5.18 ~ 6.6	1.06 ~1.28	0.39 ~0.476	0.322 ~0.298	0.243 ~0.219	0.185 ~0.167	0.164 0.151

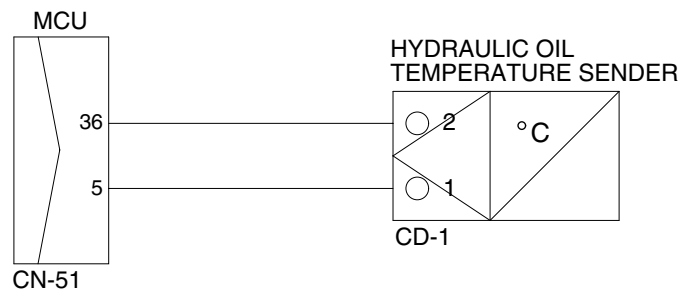

21096ES07

## 8. WHEN COOLANT TEMPERATURE GAUGE DOES NOT OPERATE (HCESPN 304, FMI 3 or 4)

- Before disconnecting the connector, always turn the starting switch OFF.
- Before carrying out below procedure, check all the related connectors are properly inserted.
- After checking, insert the disconnected connectors again immediately unless otherwise specified.

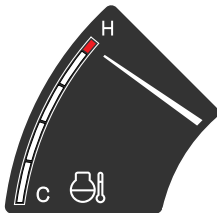
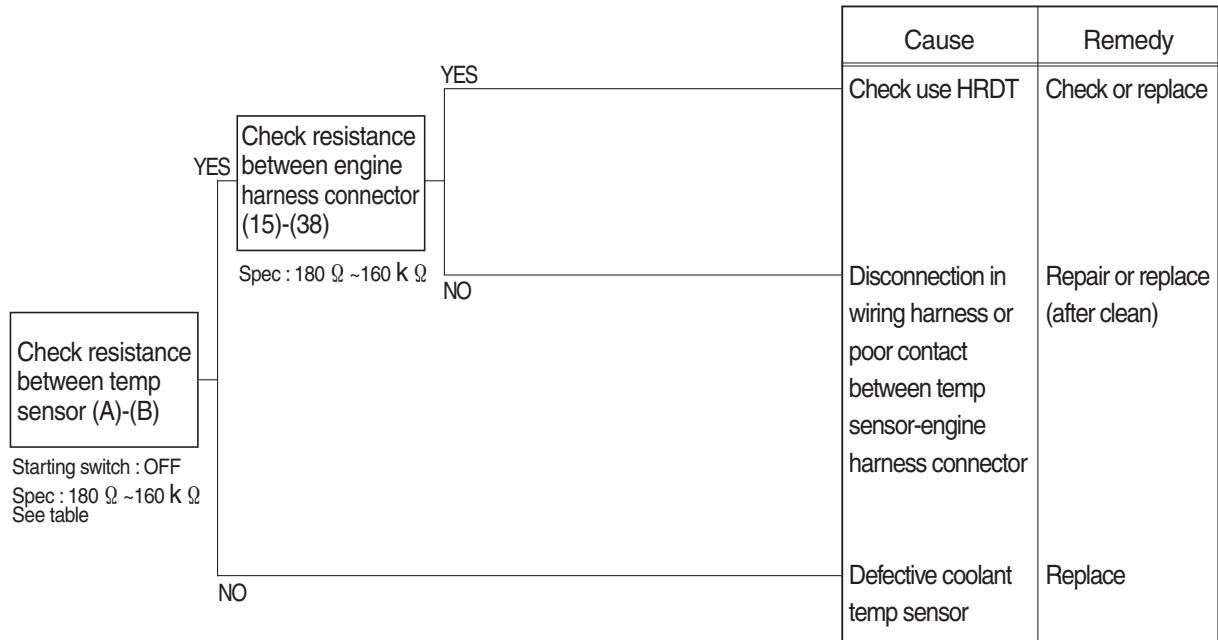

Check Table

Temperature (°C)	0	25	50	80	95
Resistance (k Ω)	30~37	9.3~10.7	3.2~3.8	1.0~1.3	0.7~0.8

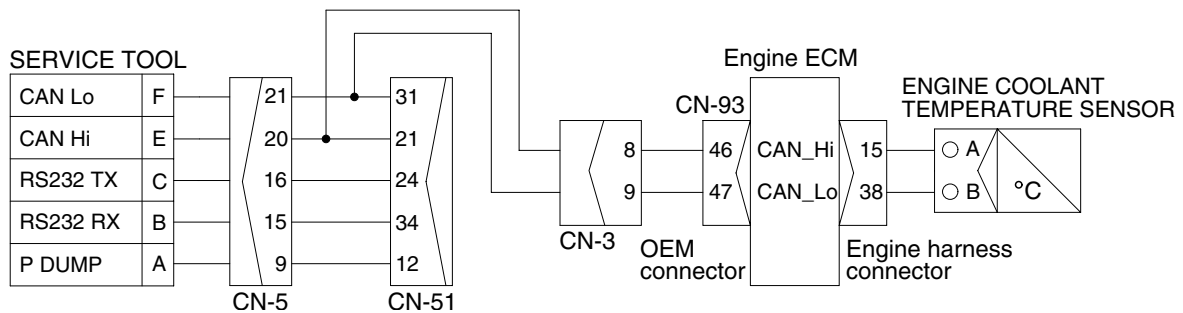

## 9. WHEN FUEL GAUGE DOES NOT OPERATE(HCESPN 301, FMI 3 or 4)

- Before disconnecting the connector, always turn the starting switch OFF.
- Before carrying out below procedure, check all the related connectors are properly inserted.
- After checking, insert the disconnected connectors again immediately unless otherwise specified.

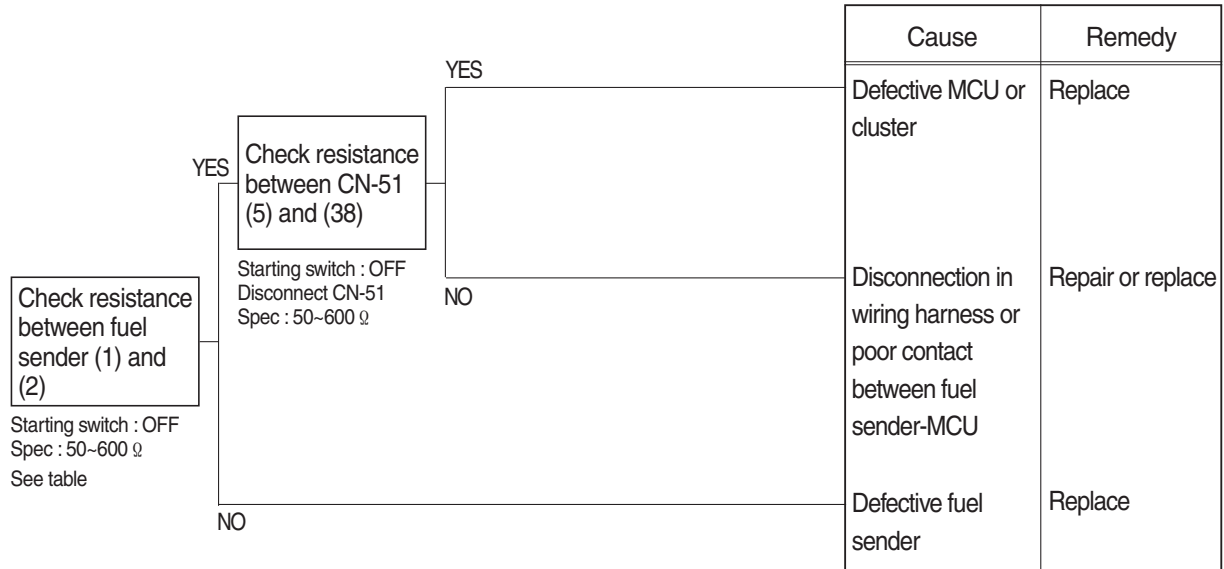

Check Table



Range	Resistance ( Ω )	Range	Resistance ( Ω )
Full	50	5/12	400
11/12	100	4/12	450
10/12	150	3/12	500
9/12	200	2/12	550
8/12	250	1/12	600
7/12	300	Empty warning	700
6/12	350	-	-

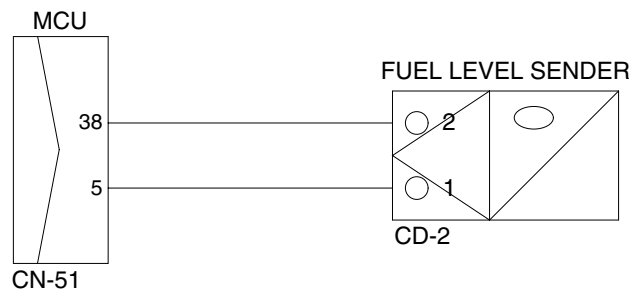

21096ES09

## 10. WHEN SAFETY SOLENOID DOES NOT OPERATE

- Before disconnecting the connector, always turn the starting switch OFF.
- Before carrying out below procedure, check all the related connectors are properly inserted and short of fuse No.23.
- After checking, insert the disconnected connectors again immediately unless otherwise specified.

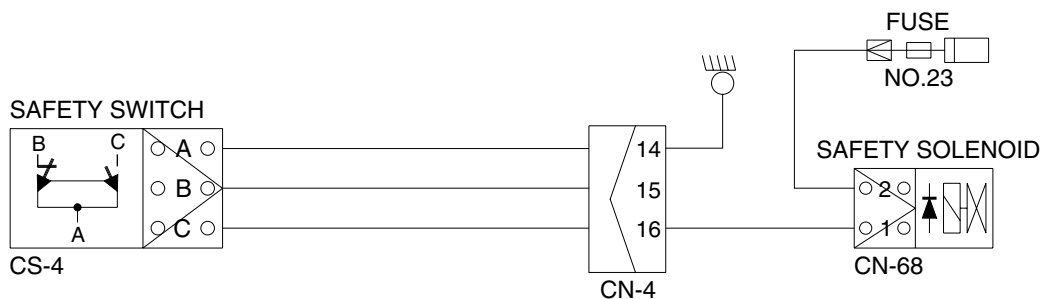
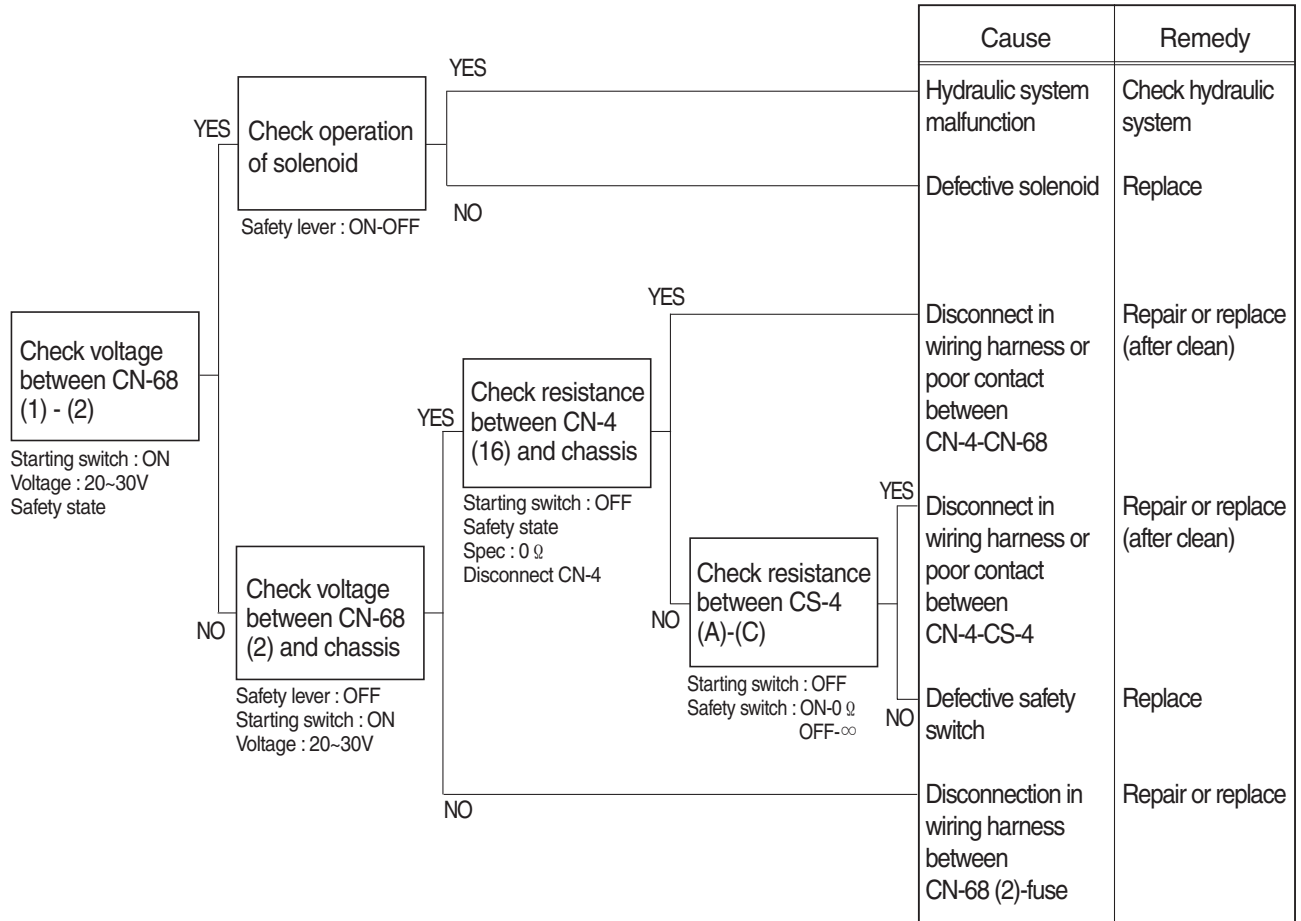

21096ES10

## 11. WHEN TRAVEL SPEED 1, 2 DOES NOT OPERATE (HCESPN 167, FMI 5 or 6)

- Before disconnecting the connector, always turn the starting switch OFF.
- Before carrying out below procedure, check all the related connectors are properly inserted and short of fuse No.25 .
- After checking, insert the disconnected connectors again immediately unless otherwise specified.

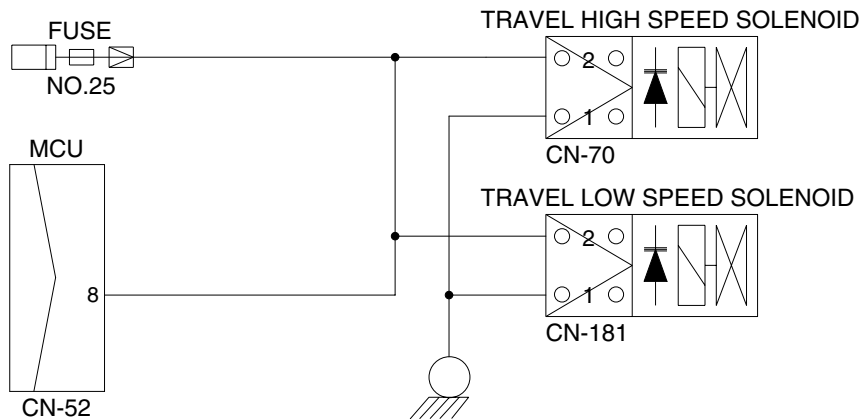
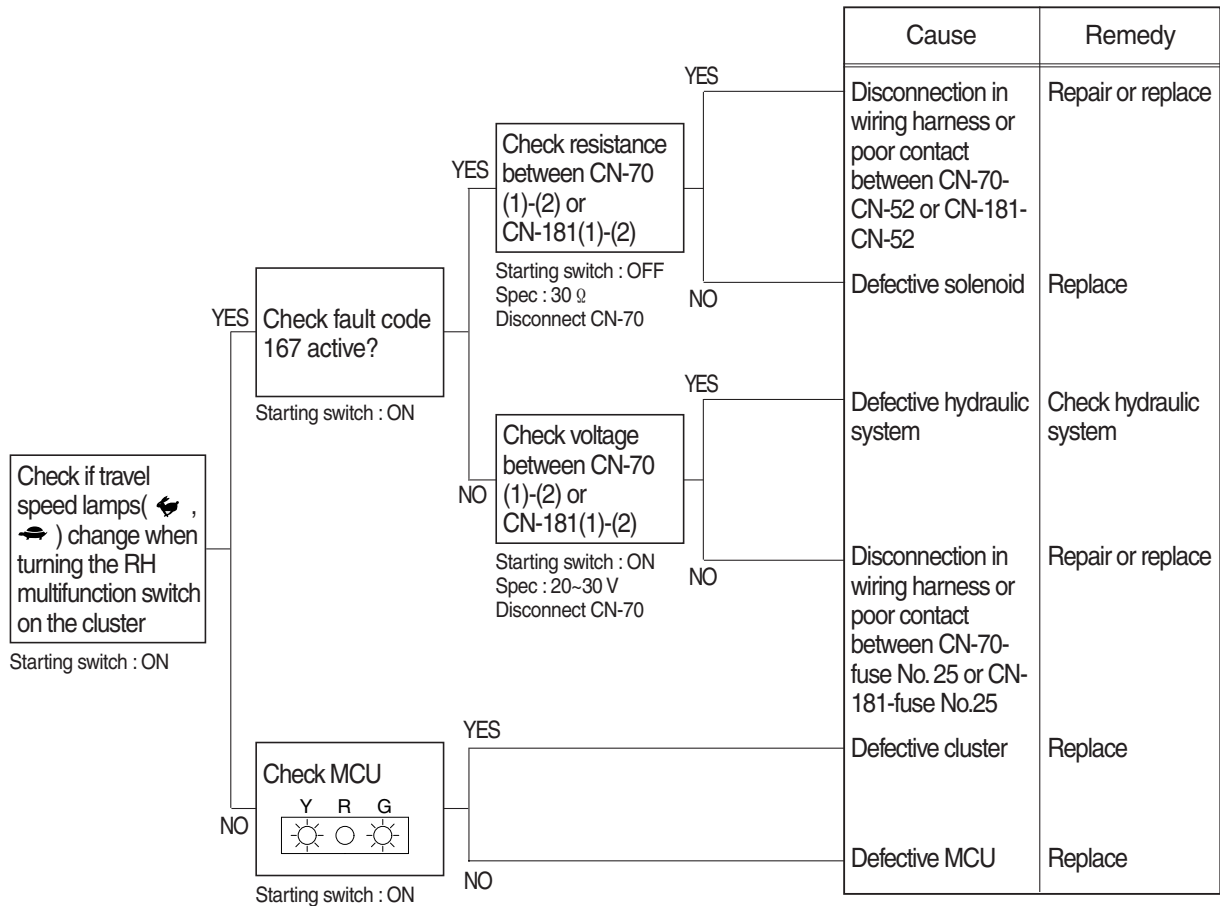

14W96ES11

## 12. WHEN ENGINE DOES NOT START ( lights up condition)

- Before disconnecting the connector, always turn the starting switch OFF.
- Before carrying out below procedure, check all the related connectors are properly inserted and short of fuse No. 1, 4, 9, 20.
- After checking, insert the disconnected connectors again immediately unless otherwise specified.

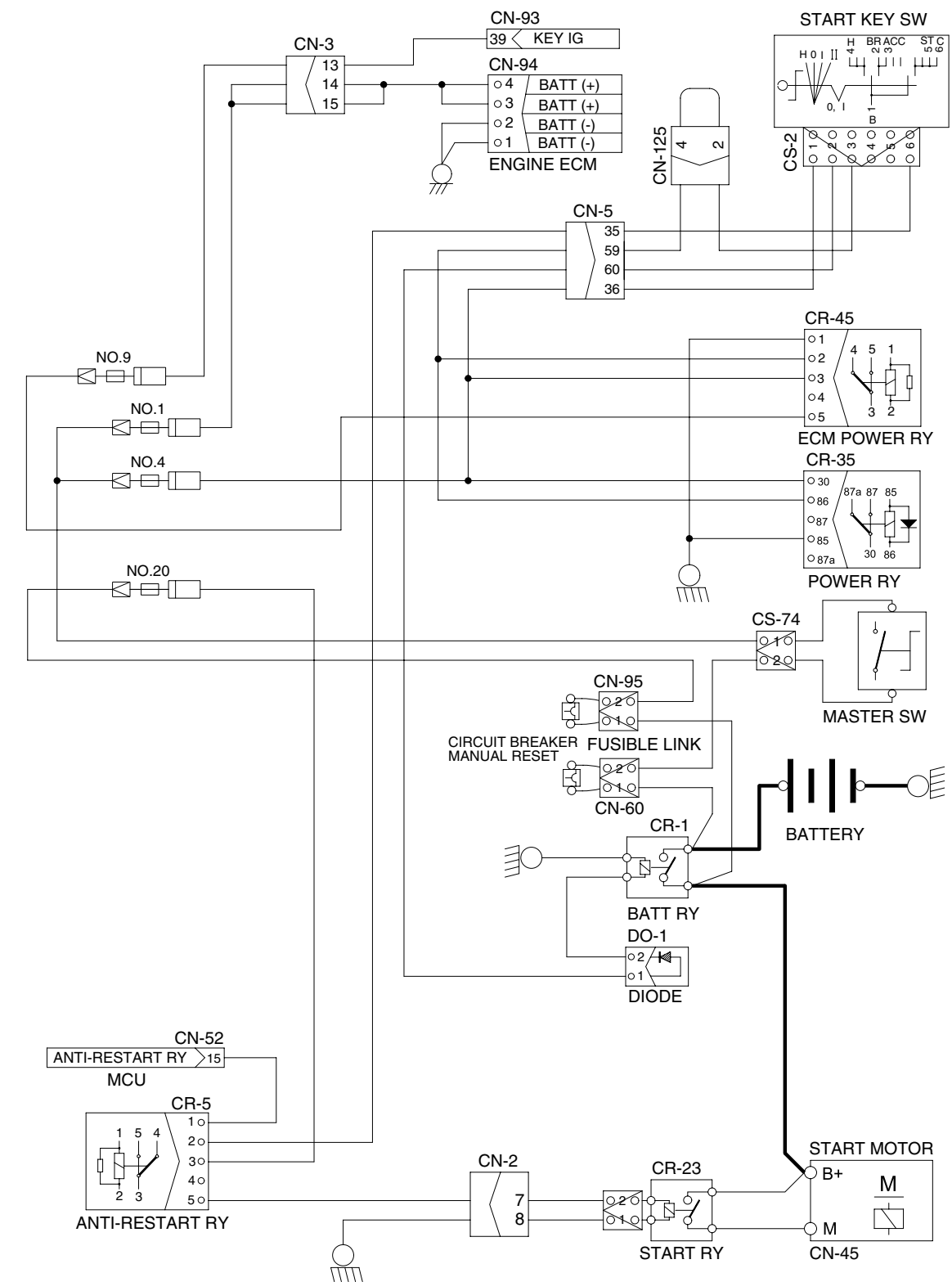
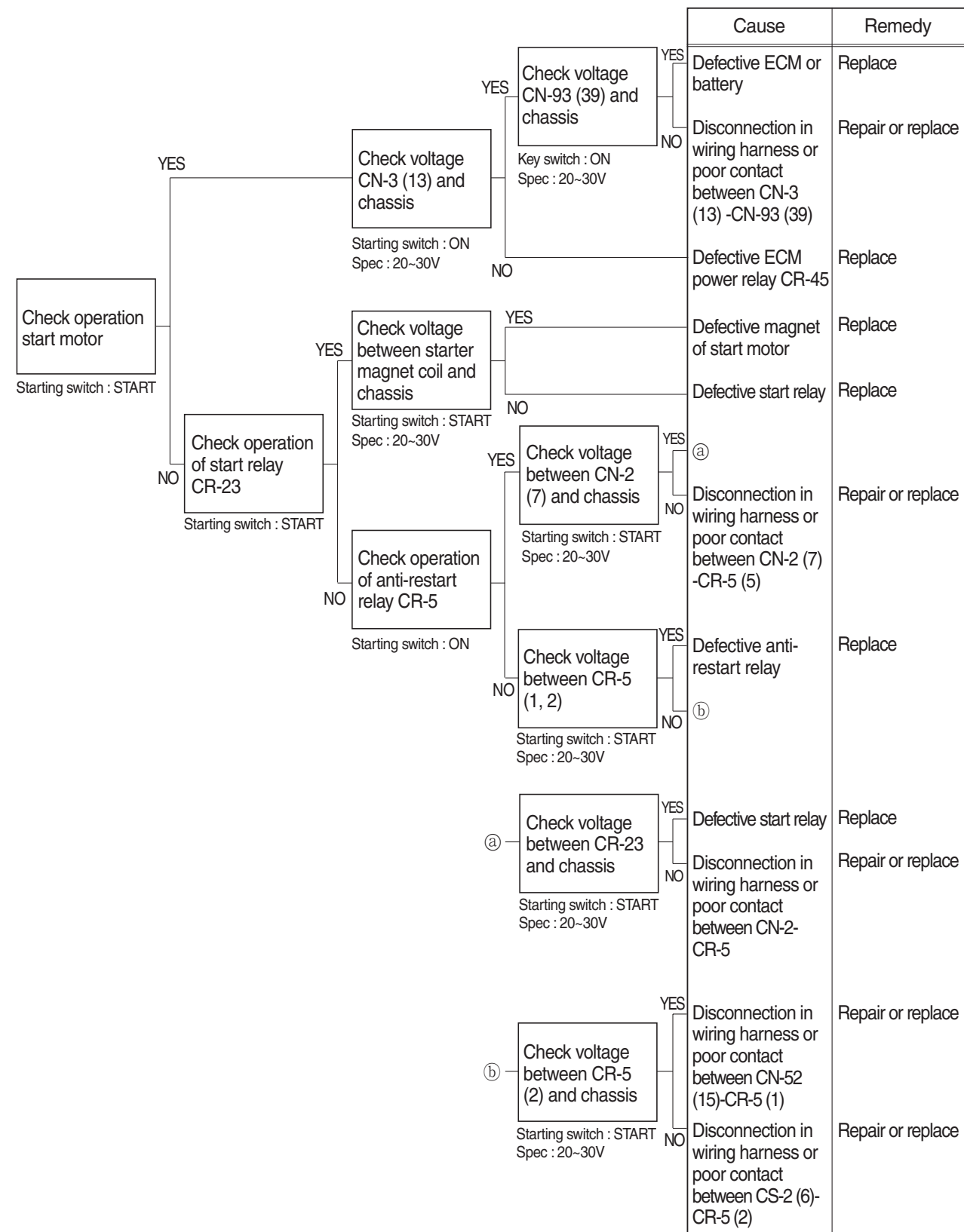

### 13. WHEN STARTING SWITCH ON DOES NOT OPERATE

- Before disconnecting the connector, always turn the starting switch OFF.
- Before carrying out below procedure, check all the related connectors are properly inserted, master switch ON and check open circuit of fusible link (CN-60).
- After checking, insert the disconnected connectors again immediately unless otherwise specified.

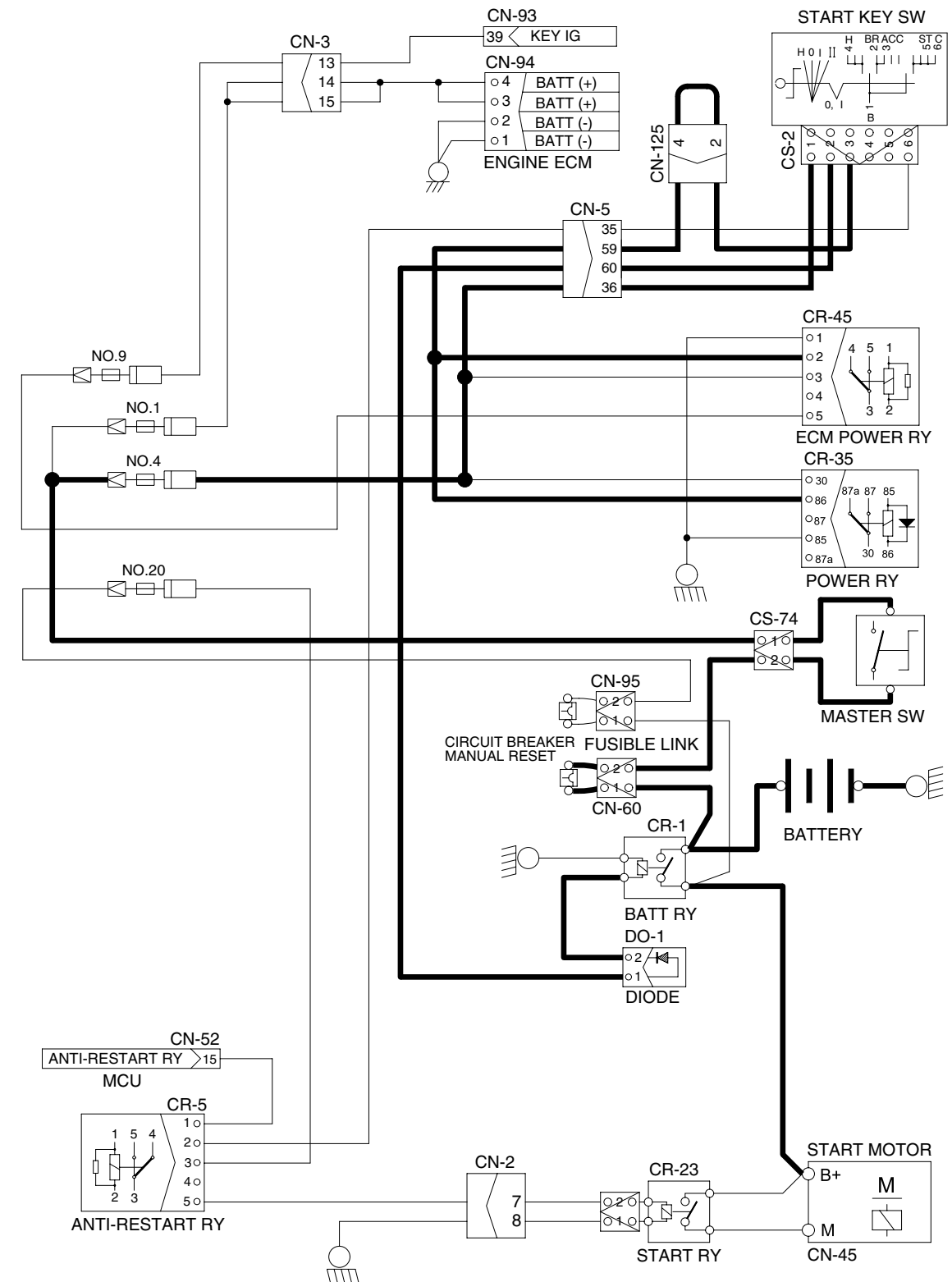
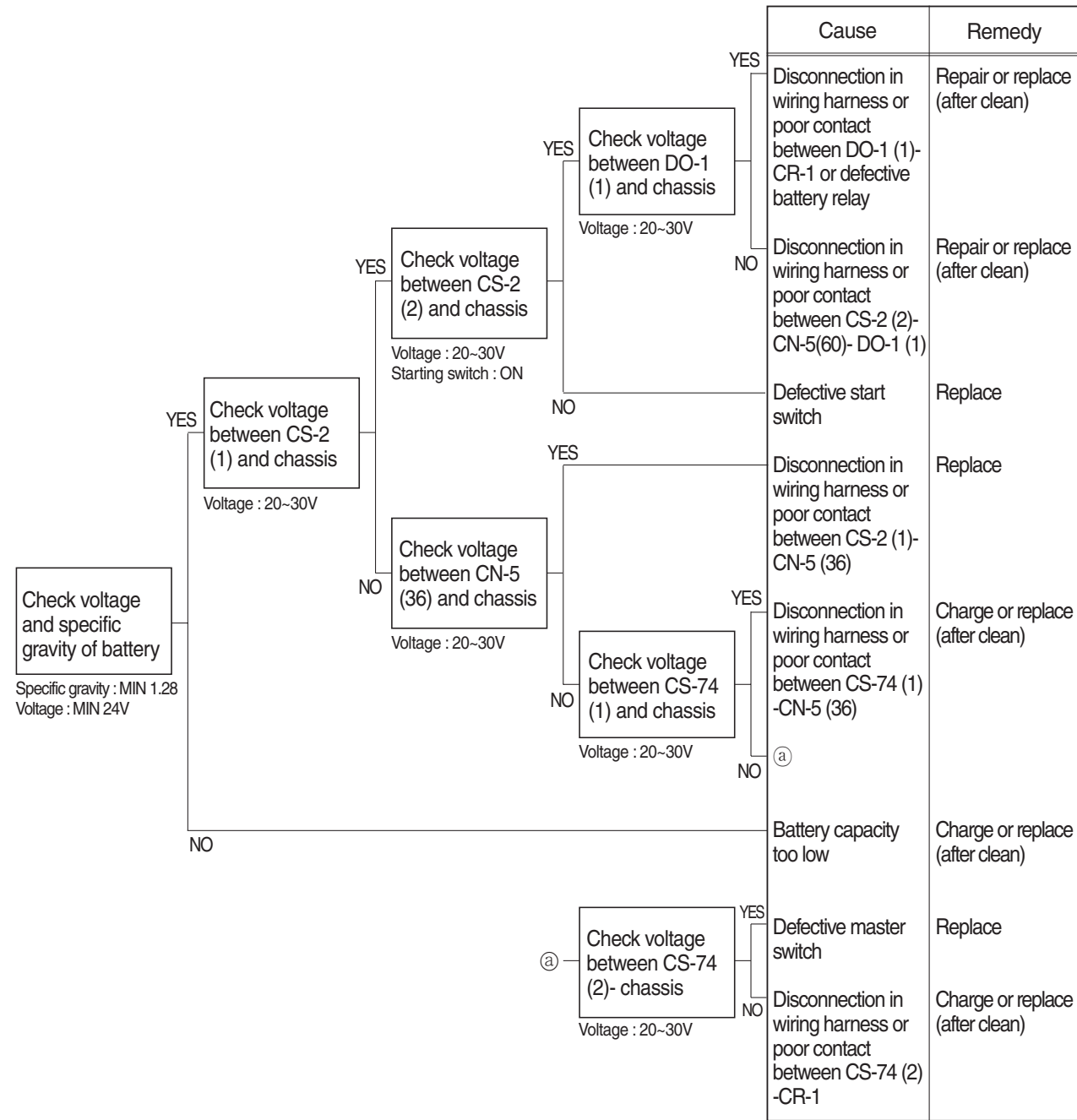

## 14. WHEN STARTING SWITCH IS TURNED ON, WIPER MOTOR DOES NOT OPERATE

- Before disconnecting the connector, always turn the starting switch OFF.
- Before carrying out below procedure, check all the related connectors are properly inserted and the fuse No. 6, 17 and 18 is not blown out.
- After checking, insert the disconnected connectors again immediately unless otherwise specified.

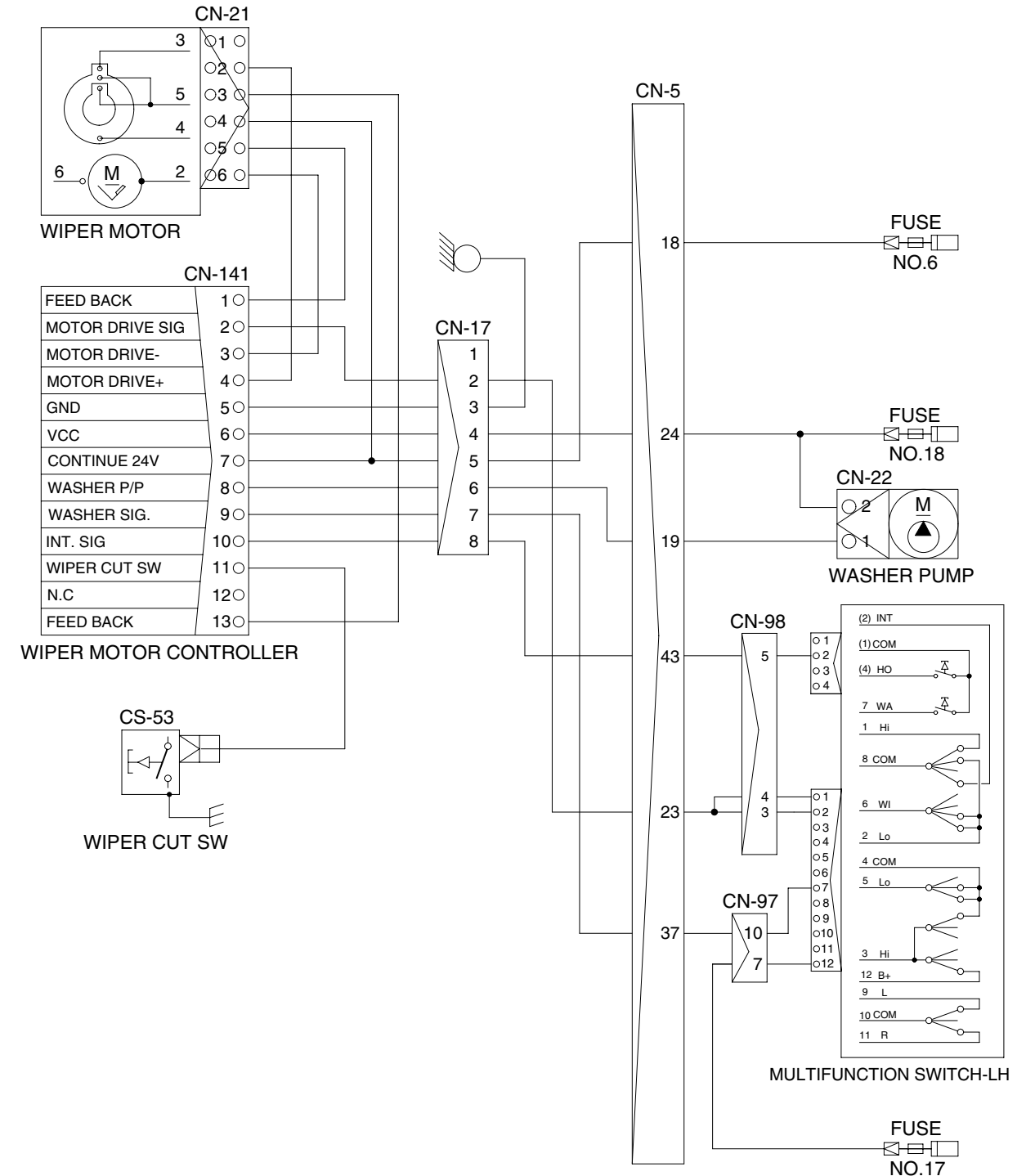
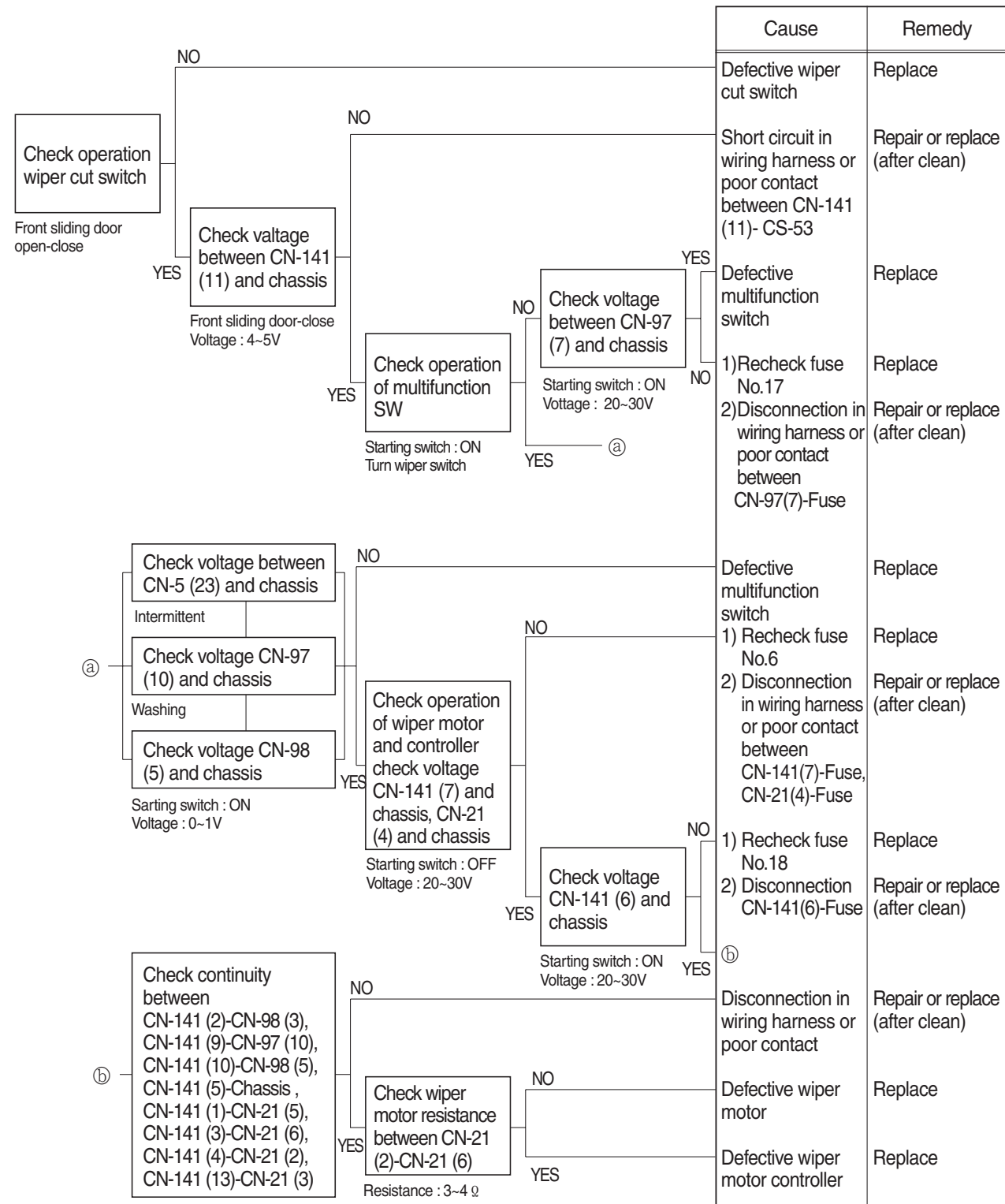

**15. WHEN STARTING SWITCH IS TURNED ON, HEAD LAMP DOES NOT LIGHTS UP**

- Before disconnecting the connector, always turn the starting switch OFF.
- Before carrying out below procedure, check all the related connectors are properly inserted and short of fuse No.17.
- After checking, insert the disconnected connectors again immediately unless otherwise specified.

		Cause	Remedy
YES	Check voltage between CL-4(2) and chassis, CL-3(2) and chassis Voltage : 20~30V	Defective bulb	Replace
		Disconnection in wiring harness or poor contact between CN-151 (8)-CL-4 (1) or CN-151(8)-CL-3(2)	Repair or replace (after clean)
NO	Check voltage between CN-98 (2) and chassis Starting switch : ON Head lamp switch : ON Voltage : 20~30V	Defective multifunction switch	Replace
		Disconnection in wiring harness or poor contact between CN-98 (2)-CN-151 (9)	Repair or replace (after clean)
YES	Check voltage between CN-152 (14) and chassis, CN-152 (15) and chassis Starting switch : ON Voltage : 20~30V Head lamp switch : ON	Disconnection in wiring harness or poor contact between CN-152 (14) and chassis or CN-152 (15)-chassis	Repair or replace (after clean)
		Recheck fuse No. 17	Replace
NO	Check voltage between CN-5 (49) and chassis Starting switch : ON Voltage : 20~30V Head lamp switch : ON	Defective switch panel	Replace
		Disconnection in wiring harness or poor contact between CN-5(49) and CN-116(2)	Repair or replace (after clean)
NO	Check voltage between CN-116 (2) and chassis Starting switch : ON Head lamp switch : ON-OFF	Disconnection in wiring harness or poor contact between CN-5(49) and CN-116(2)	Repair or replace (after clean)

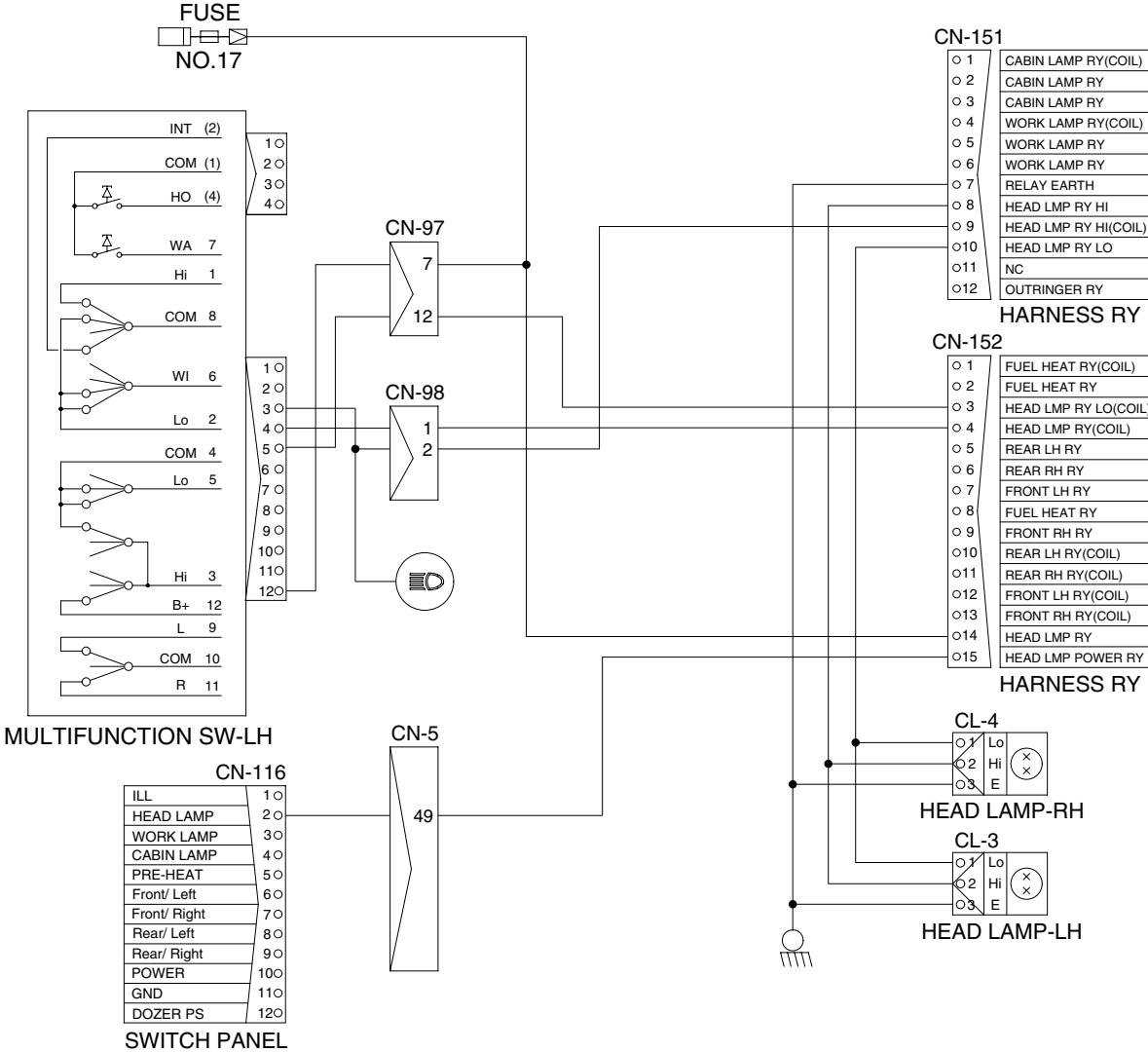

**16. WHEN STARTING SWITCH IS TURNED ON, WORK LAMP DOES NOT LIGHTS UP**

- Before disconnecting the connector, always turn the starting switch OFF.
- Before carrying out below procedure, check all the related connectors are properly inserted and short of fuse No.15.
- After checking, insert the disconnected connectors again immediately unless otherwise specified.

