

GROUP 2 MAIN CONTROL VALVE

1. STRUCTURE

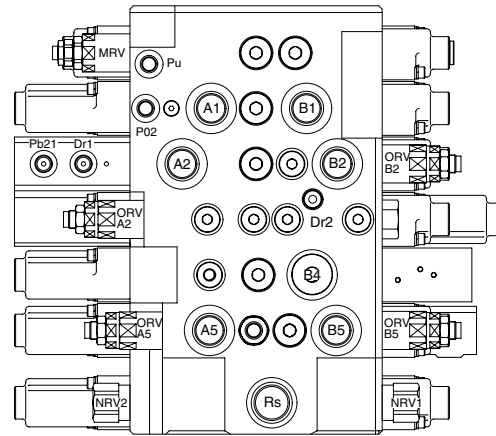

VIEW A

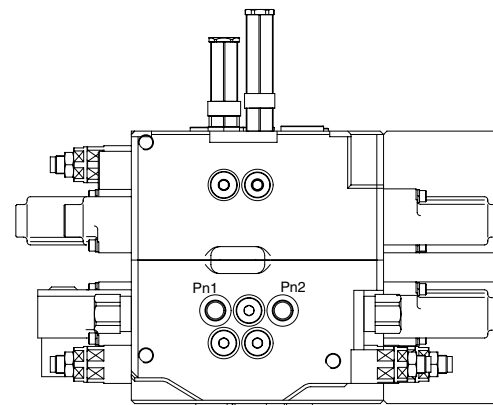
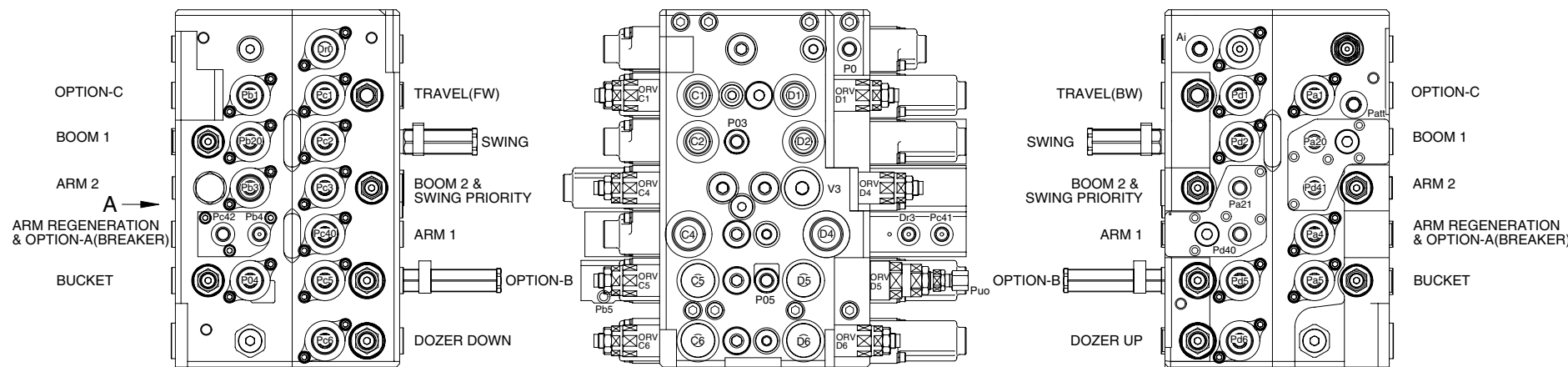
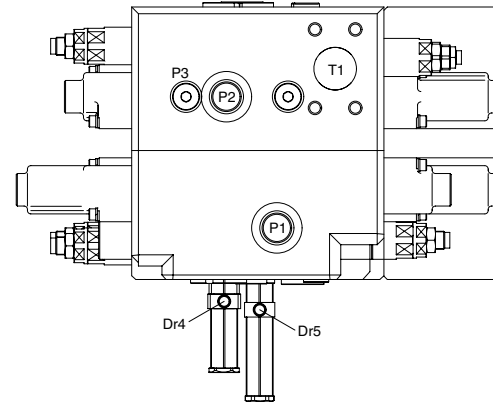

Mark	Port name	Port size	Tightening torque		
Rs	Make up for swing motor	UNF 1 3/16	18 kgf · m (130 lbf · ft)		
Pa1	Option C pilot port	PF 1/4	3.5~3.9 kgf · m (25.3~28.2 lbf · ft)		
Pb1	Option C pilot port				
Pc1	Travel pilot port (FW)				
Pd1	Travel pilot port (BW)				
Pa20	Boom up pilot port				
Pa21	Boom up confluence pilot port				
Pb20	Boom down pilot port				
Pb21	Boom holding valve pilot port				
Pc2	Swing pilot port (RH)				
Pd2	Swing pilot port (LH)				
Pb3	Arm in confluence pilot port				
Pc3	Swing priority pilot port				
Pa4	Option A pilot port (breaker)				
Pb4	Arm in regeneration cut port				
Pc40	Arm in pilot port				
Pc41	Arm holding valve pilot port				
Pc42	Arm in regen-cut signal selector port				
Pd40	Arm out pilot port				
Pd41	Arm out confluence pilot port				
Pa5	Bucket in pilot port				
Pb5	Bucket out pilot port				
Pc5	Option B pilot port				
Pd5	Option B pilot port				
Pc6	Dozer down pilot port				
Pd6	Dozer up pilot port				
P0	Pilot pressure port				
Pu	Main relief pressure up				
Ai	Auto idle signal port				
Patt	Auto idle signal-attachment				
P02	Pilot signal port				
P03	Boom priority pilot port				
P04	Boom parallel orifice pilot port				
P05	Breaker summation pilot port				
P3	Quick clamp port				
Puo	Pilot pressure port				
Dr0	Drain port (travel straight)				
Dr1	Drain port (boom holding valve)				
Dr2	Drain port (boom2 & swing priority)				
Dr3	Drain port (arm holding valve)				
Pn1	Negative control signal port (P1 port side)			PF 3/8	7~8 kgf · m (50.6~57.8 lbf · ft)
Pn2	Negative control signal port (P2 port side)				
A1	Option C port			PF 3/4	15~18 kgf · m (109~130 lbf · ft)
B1	Option C port				
C1	Travel motor port (FW)				
D1	Travel motor port (BW)				
B2	Boom rod side port				
C2	Swing motor port (RH)				
D2	Swing motor port (LH)				
B4	Option A port (breaker)				
A5	Bucket head side port				
B5	Bucket rod side port				
C5	Option B port				
D5	Option B port				
C6	Dozer down port				
D6	Dozer up port				
P1	Pump port (P1 side)				
P2	Pump port (P2 side)				
A2	Boom head side port	PF 1	20~25 kgf · m (115~180 lbf · ft)		
C4	Arm head side port				
D4	Arm rod side port	PF 1/8	1.5~1.9 kgf · m (10.8~13.7 lbf · ft)		
Dr4	Drain port (swing logic valve)				
Dr5	Drain port (flow summation)				
T1	Return port	SAE3000, 1 1/2 (M12 × 1.75)	8.5~11.5 kgf · m (61.5~83.1 lbf · ft)		

17W92MC01

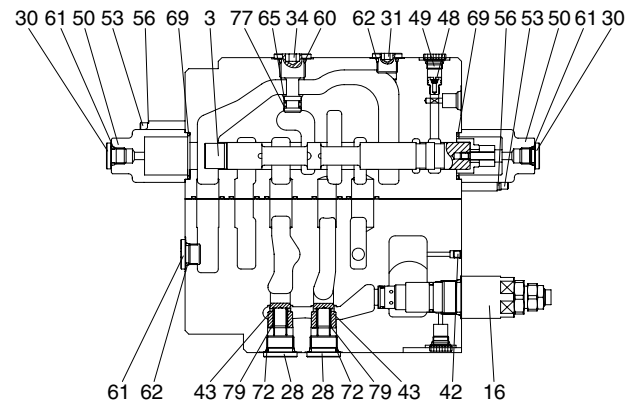

A-A (STRAIGHT-TRAVEL & SUPPLY)

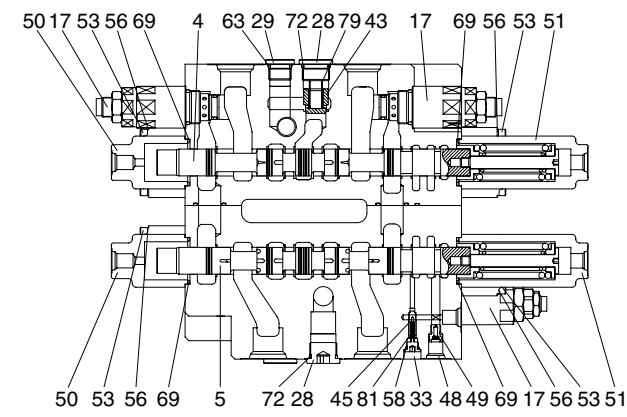

B-B (TRAVEL & OPTION-C)

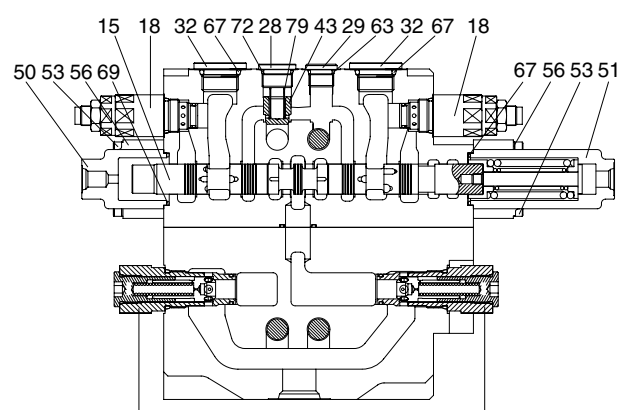

G-G (DOZER & NEGATIVE CONTROL)

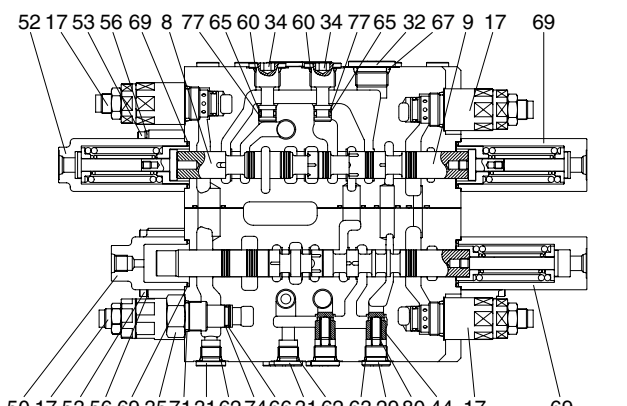

D-D (SWING PRIORITY & BOOM 2 & ARM 2)

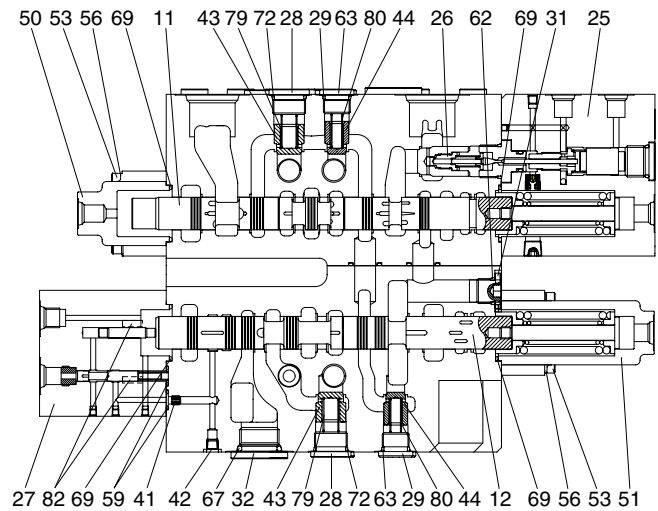

E-E (ARM 1 & ARM REGENERATION / BREAKER)

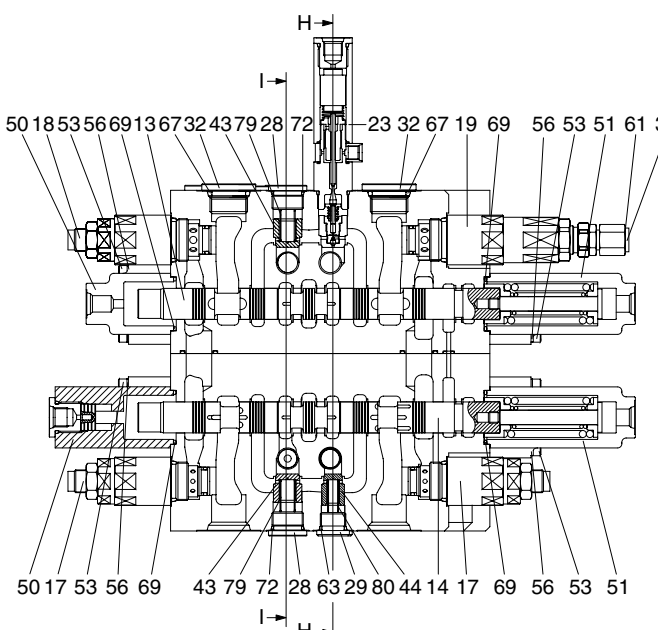

F-F (OPTION-B & BUCKET)

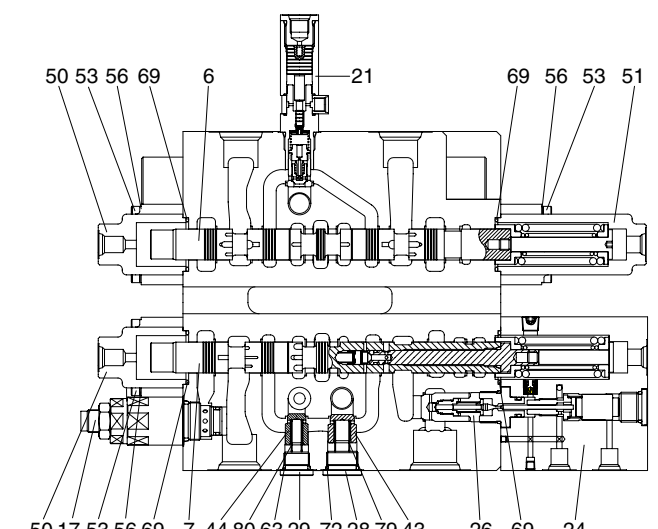

C-C (SWING & BOOM 1)

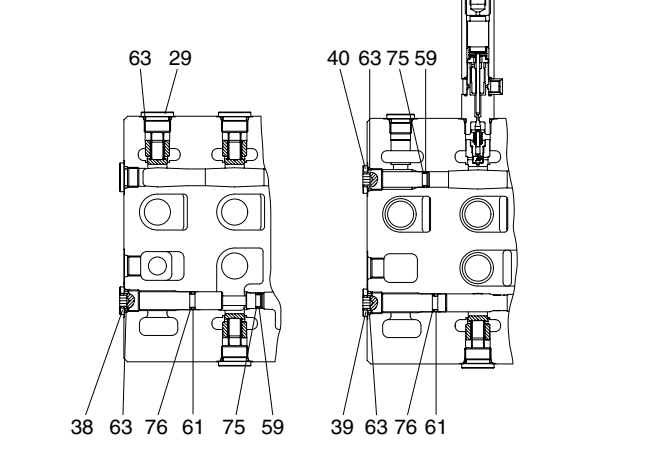
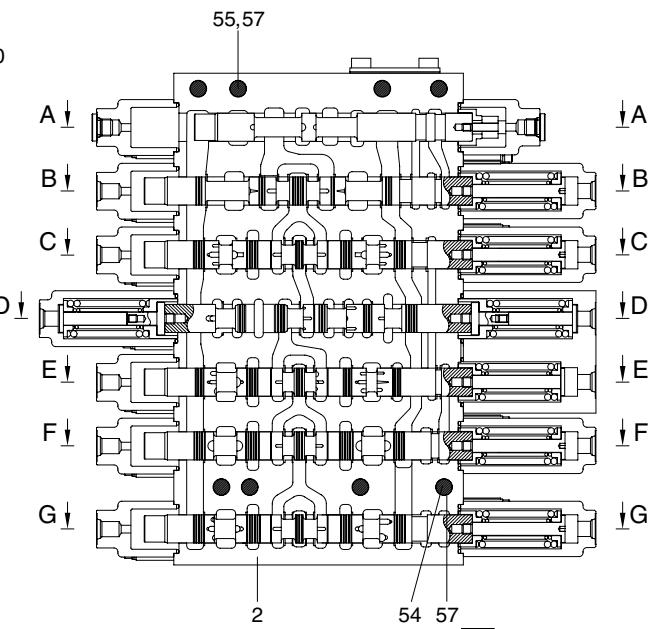
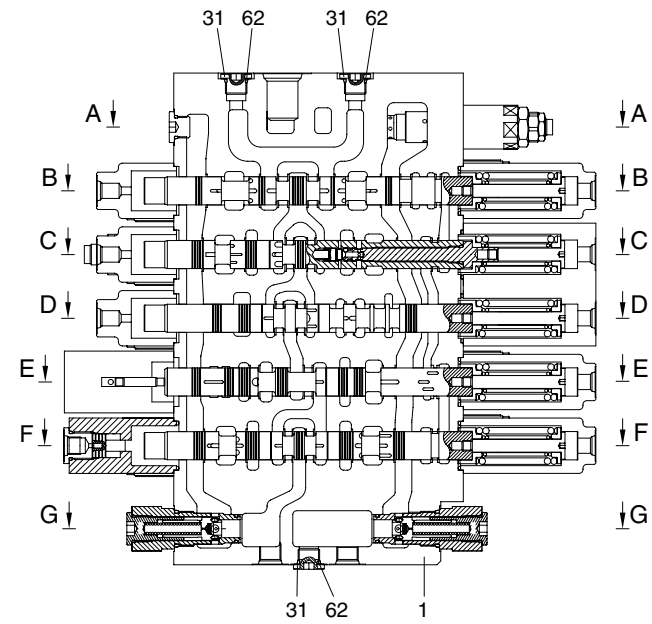

SECTION I-I SECTION H-H

- | | |
|-------------------------------------|---------------------------|
| 1 Housing-P1 | 42 Plug |
| 2 Housing-P2 | 43 Load check-poppet |
| 3 Spool-straight travel | 44 Load check-poppet |
| 4 Spool-travel | 45 Signal-poppet |
| 5 Spool-option C | 46 Travel straight-sleeve |
| 6 Spool-swing | 47 Travel straight-piston |
| 7 Spool-boom 1 | 48 Orifice signal |
| 8 Spool-swing priority | 49 Coin type filter |
| 9 Spool-boom 2 | 50 Pilot cap |
| 10 Spool-arm 2 | 51 Pilot cap |
| 11 Spool-arm 1 | 52 Pilot cap |
| 12 Spool-arm regeneration & breaker | 53 Socket bolt |
| 13 Spool-option B | 54 Socket bolt |
| 14 Spool-bucket | 55 Socket bolt |
| 15 Spool-dozer | 56 Plain washer |
| 16 Main relief valve | 57 Spring washer |
| 17 Overload relief valve | 58 O-ring |
| 18 Overload relief valve | 59 O-ring |
| 19 Overload relief valve | 60 O-ring |
| 20 Negacon relief valve | 61 O-ring |
| 21 Swing logic valve | 62 O-ring |
| 22 Bucket stroke limiter | 63 O-ring |
| 23 Option on-off valve | 64 O-ring |
| 24 Holding valve kit A1 | 65 O-ring |
| 25 Holding valve kit A2 | 66 O-ring |
| 26 Holding valve kit B | 67 O-ring |
| 27 Regeneration block | 68 O-ring |
| 28 Plug | 69 O-ring |
| 29 Plug | 70 O-ring |
| 30 Plug | 71 O-ring |
| 31 Plug | 72 O-ring |
| 32 Plug | 73 O-ring |
| 33 Plug | 74 Backup-ring |
| 34 Plug-parallel | 75 Backup-ring |
| 35 Plug-relief cat | 76 Backup-ring |
| 36 Plug-relief cat | 77 Backup-ring |
| 37 Plug-relief cat | 78 Backup-ring |
| 38 Plug-bucket | 79 Load check spring |
| 39 Plug-bucket parallel | 80 Load check spring |
| 40 Plug-option | 81 Poppet signal spring |
| 41 Plug-orifice | 82 Pin |

2. HYDRAULIC CIRCUIT

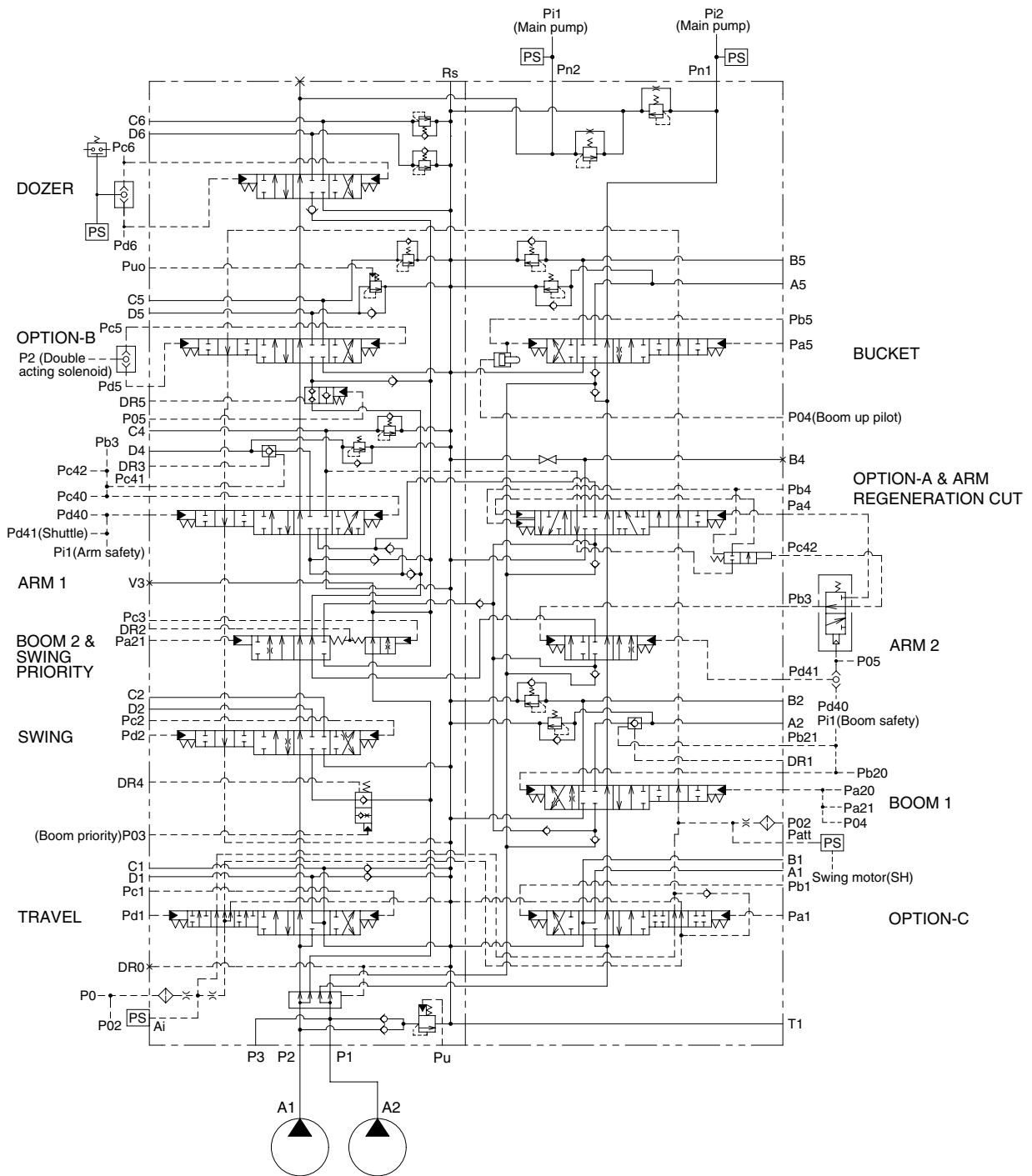

17W92MC05

3. FUNCTION

1) CONTROL IN NEUTRAL

(1) P1 SIDE

The hydraulic fluid from pump A2 flows into the main control valve through the inlet port "P1", into the P1 bypass passage and P1 parallel passage.

The hydraulic fluid from the pump A2 is directed to the tank through the bypass passage of spools : option C, boom 1, arm 2, arm regeneration & option A and bucket, the negative relief valve of P1, tank passage, and the tank port "T1"

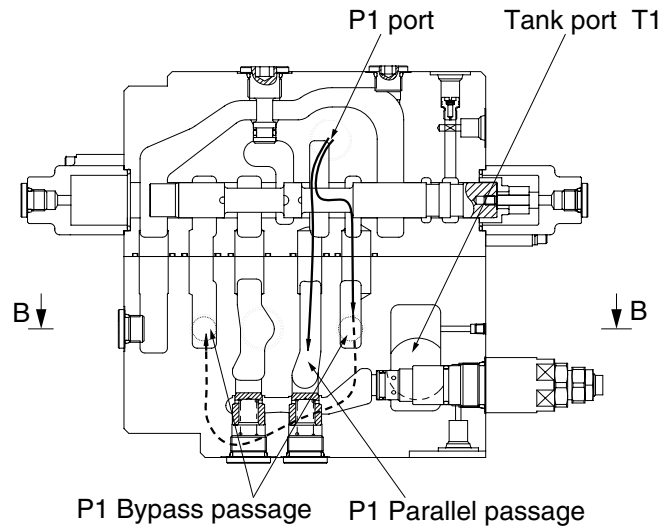

SECTION A-A

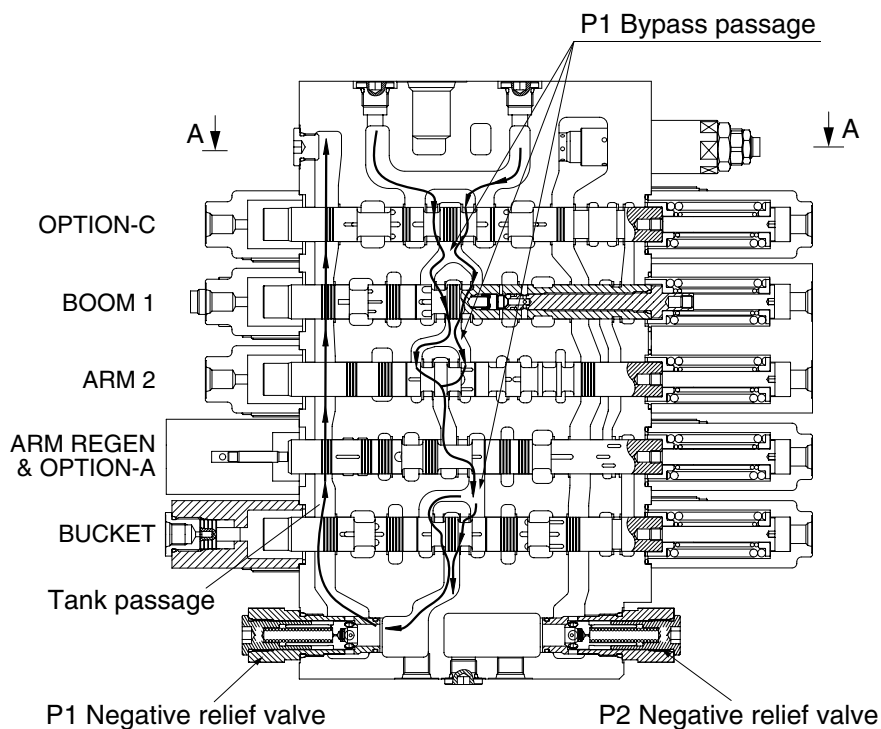

SECTION B-B

17W92MC11

(2) P2 SIDE

The hydraulic fluid from pump A1 flows into the main control valve through the inlet port "P2", into the P2 bypass passage and P2 parallel passage.

The hydraulic fluid from the pump A1 is directed to the tank through the bypass passage of spools : travel, swing, boom 2 & swing priority, arm 1, option "B" and dozer, the negative relief valve of P2, tank passage and the tank port "T1".

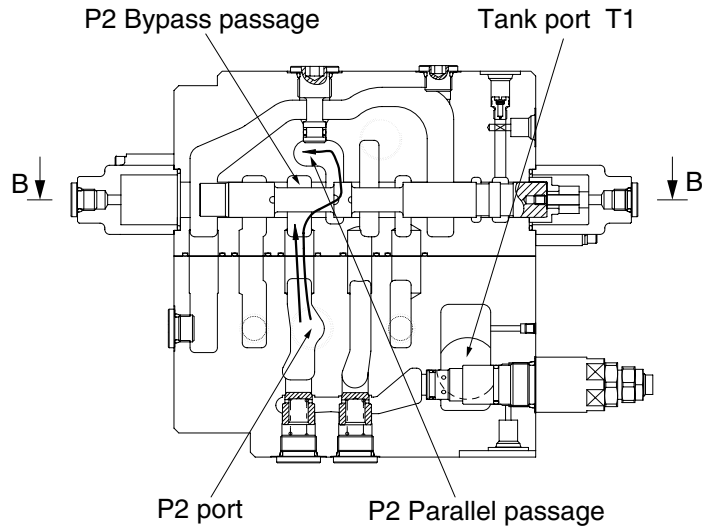

SECTION A-A

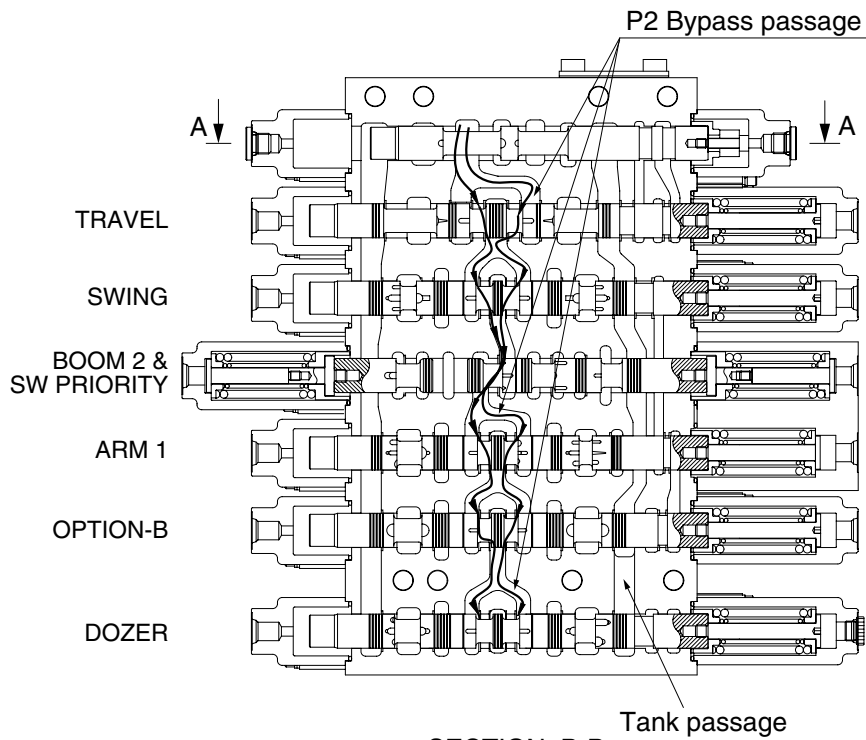

SECTION B-B

14W92MC12

2) TRAVEL OPERATION

(1) TRAVEL FORWARD OPERATION

During the travel forward operation, the pilot pressure from the solenoid valve is supplied to the port Pc1 of the spring opposite side, and it shifts travel spool in the right direction against springs. Hydraulic fluid from the pump A1 flows into the travel spool through the bypass passage.

Then the bypass passage is shut off by the movement of the travel spool, it is directed to the travel motor through port C1. At the same time, the hydraulic fluid from the travel motor through port D1 returns to the tank passage through the travel spool.

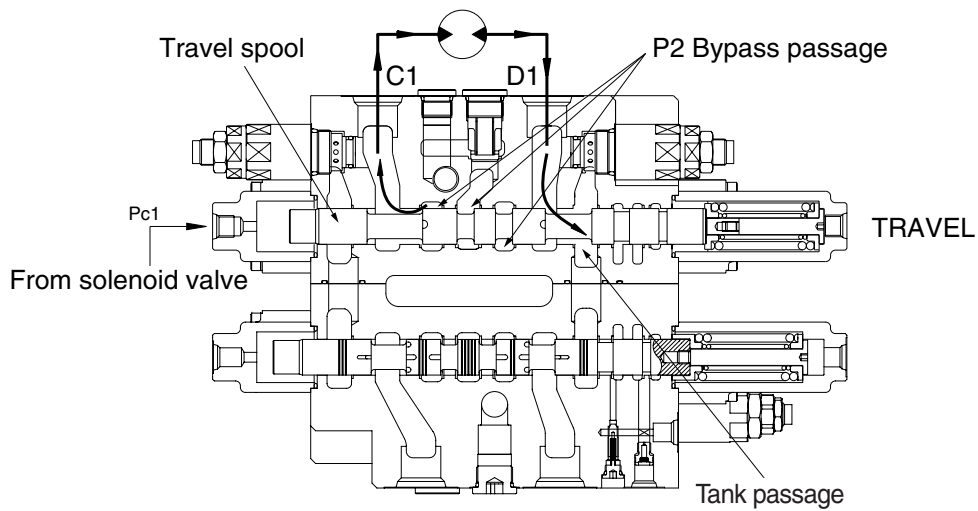

14W92MC18

(2) TRAVEL REVERSE OPERATION

During the travel reverse operation, the pilot pressure from the solenoid valve is supplied to the port Pd1 of the spring side, and it shifts travel spool in the left direction. Hydraulic fluid from the pump A1 flows into the travel spool through the bypass passage.

Then the bypass passage is shut off by the movement of the travel spool, it is directed to the travel motor through port D1. At the same time, the hydraulic fluid from the travel motor through port C1 returns to the tank passage through the travel spool.

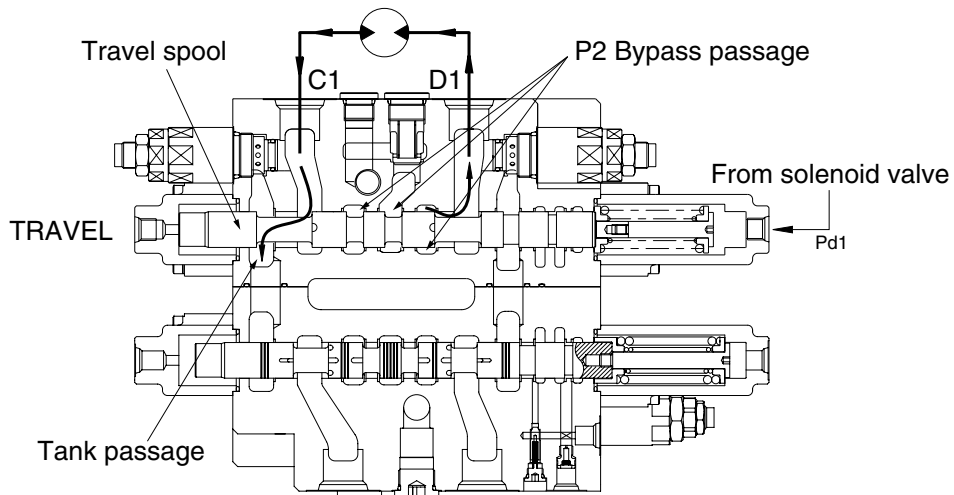

14W92MC17

3) BOOM OPERATION

(1) BOOM UP OPERATION

During boom up operation, the pilot secondary pressure from RCV is supplied to the port Pa20 of the spring side and shifts the boom 1 spool in the left direction. The bypass passage is shut off by the movement of the boom 1 spool and the hydraulic oil fluid from pump A2 is entered P1 parallel passage and then passes through the load check, bridge passage and boom holding valve then flows into the port A2. Following this it flows into the head side of the boom cylinder. (In this case, the boom holding valve is free flow condition)

At the same time, the pilot pressure from RCV is supplied to the port Pa21 of the spring side of boom 2 and shifts the boom 2 spool. The bypass passage is shut off by the movement of the boom 2 spool and the hydraulic oil fluid from pump A1 entered boom summation passage via the P2 parallel passage, the land of the swing priority spool, notch of the boom 2 spool, arm 2 spool and the check. The flows combine in passage and are directed to port A2 and head side of boom cylinder.

At the same time, the flow from rod side of the boom cylinder return to the boom 1 spool through the port B2. Thereafter it is directed to the hydraulic oil tank through the tank passage.

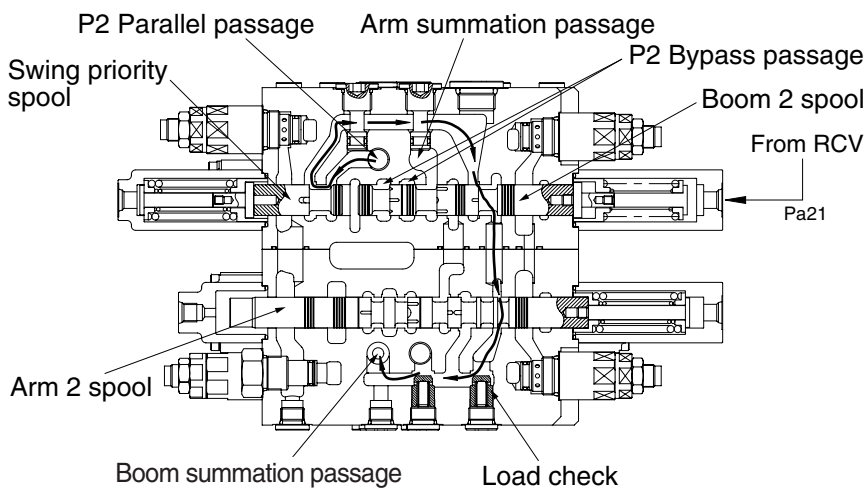
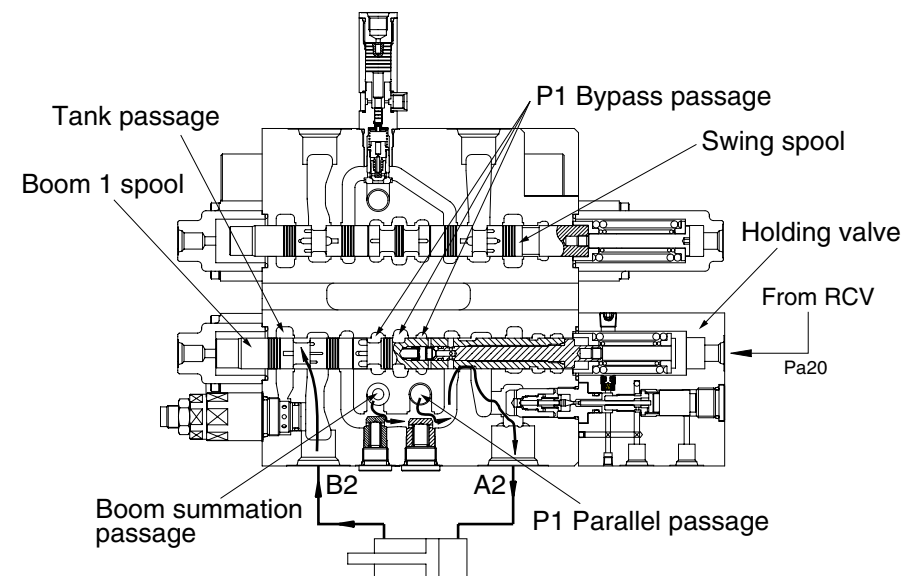

(2) BOOM DOWN OPERATION

During the boom lowering operation, the pilot pressure from RCV is supplied to the port Pb20 of the spring opposite side and shifts the boom 1 spool in the right direction.

The bypass passage is shut off by the movement of the boom 1 spool and the hydraulic fluid from the pump A2 enters the parallel passage and is directed to the port B2 through the load check. Following this, it flows into the rod side of the boom cylinder.

At the same time, the return flow from the head side of the boom cylinder returns to the port A2 and boom holding valve. And it is directed to the hydraulic oil tank through opened tank passage by movement of the boom 1 spool.

Meanwhile some of return flow is directed to P1 parallel passage through the internal passage of the boom 1 spool. (boom regeneration)

In this case, the holding valve is open condition, for details of the boom holding valve, see page following page.

During the boom lowering operation, the fluid from A1 pump is not summation.

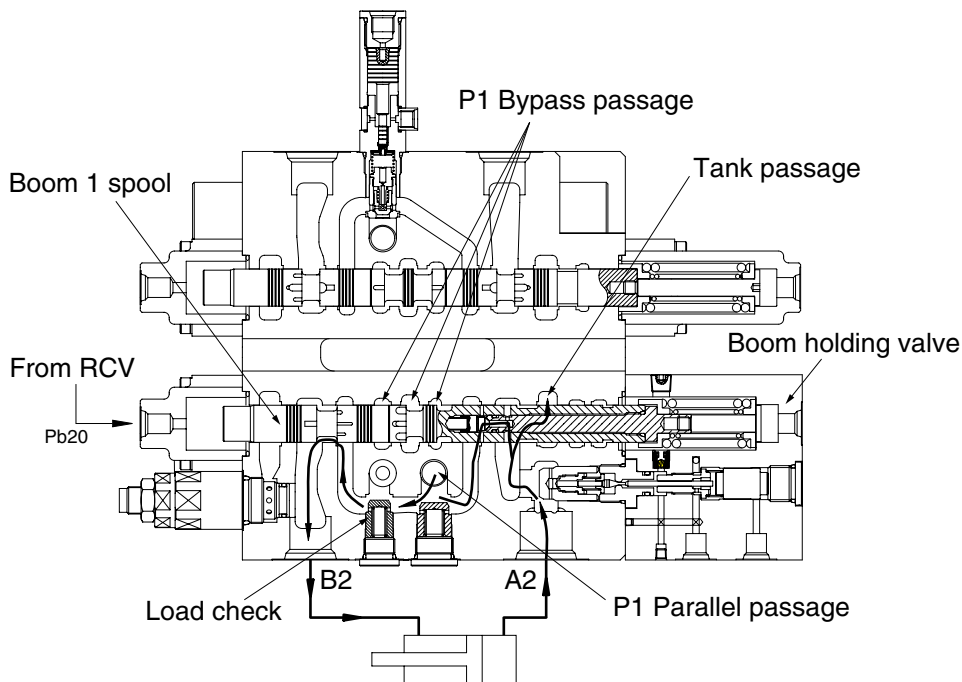

14W92MC26

4) HOLDING VALVE OPERATION

(1) HOLDING OPERATION

At neutral condition, the pilot piston chamber is connected to drain port through the pilot port.

And the piston "B" is supported with spring "B".

Also, the pressured fluid from actuator entered to inside of the holding valve through the periphery hole of check, crevice of the check and the plug and the periphery hole of plug.

Then, this pressured oil pushed the poppet to the poppet seat and the check to the seat of body.

So the hydraulic fluid from actuator is not escaped and the actuator is not moved.

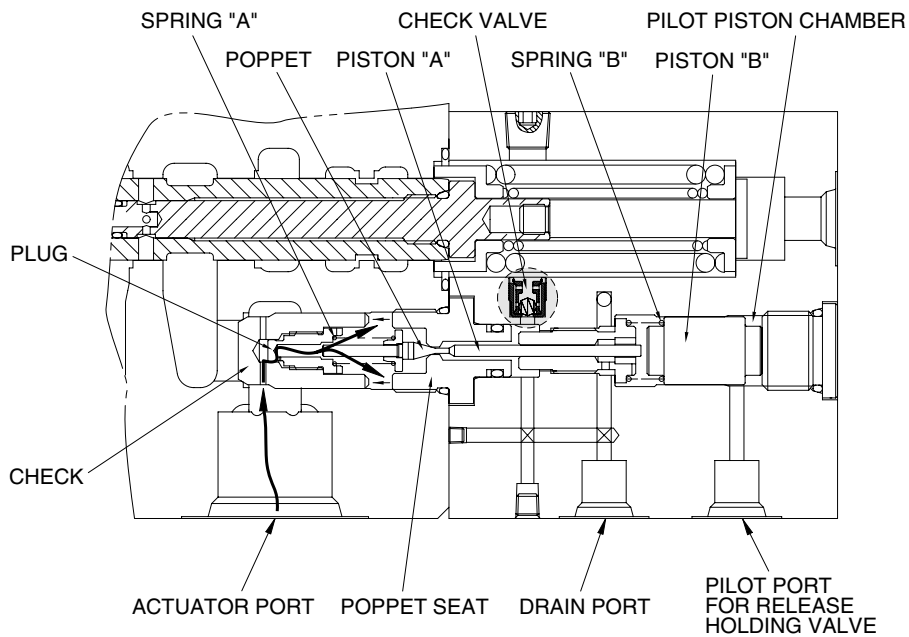

14W92MC15

(2) RELEASE HOLDING OPERATION

The pilot pressure is supplied to the pilot port for release holding valve and shifts the piston "B" in the left direction against the spring "B", and shifts the poppet in the left direction through piston "B" and piston "A" against spring "B" and shifts the spool in the left side.

At same time, the return fluid from actuator returns to the drain port through the periphery hole of check, crevice of the check and the plug, the periphery hole of the plug, in side of holding valve, crevice of the poppet and the poppet seat, the periphery hole of the poppet seat, crevice of socket and spool and internal passage of spool.

When the poppet is opened, pressure of inside of holding valve is decreased and the return fluid from actuator returns to the tank passage through the notch of spool.

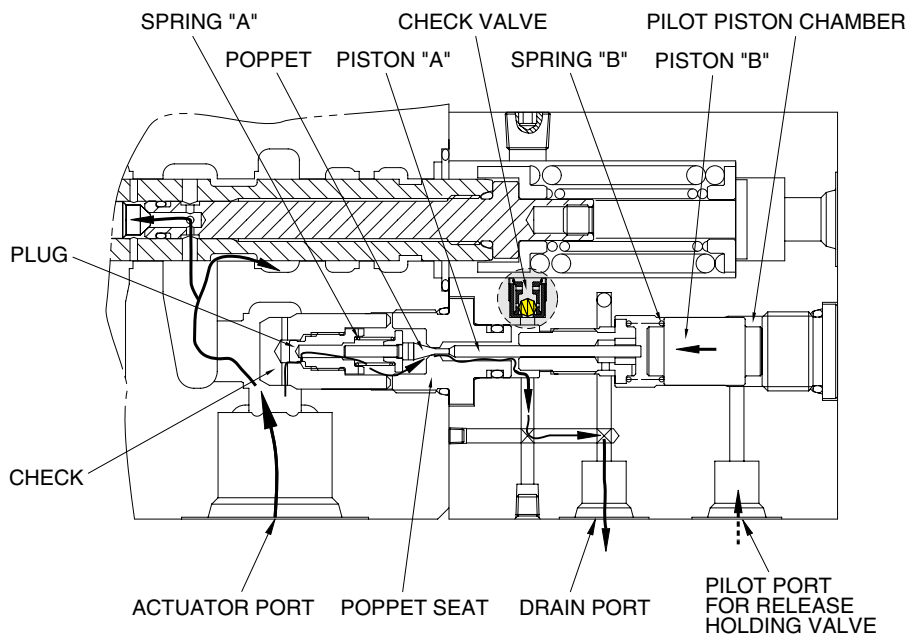

14W92MC16

5) BUCKET OPERATION

(1) BUCKET IN OPERATION

During the bucket in operation, the pilot secondary pressure from RCV is supplied to port Pa5 of the spring side and shifts the bucket spool in the left direction.

The bypass passage is shut off by the movement of the bucket spool and the hydraulic fluid from pump A2 entered P1 parallel passage and is directed to the port A5 through the check 1.

At the same time, the hydraulic fluid from P1 bypass passage is directed to the port A5 through the check 2.

Following this it flows into the head side of the bucket cylinder.

The return flow from the rod side of the bucket cylinder returns to the bucket spool through the port B5. Thereafter it is directed to the hydraulic oil tank through the tank passage.

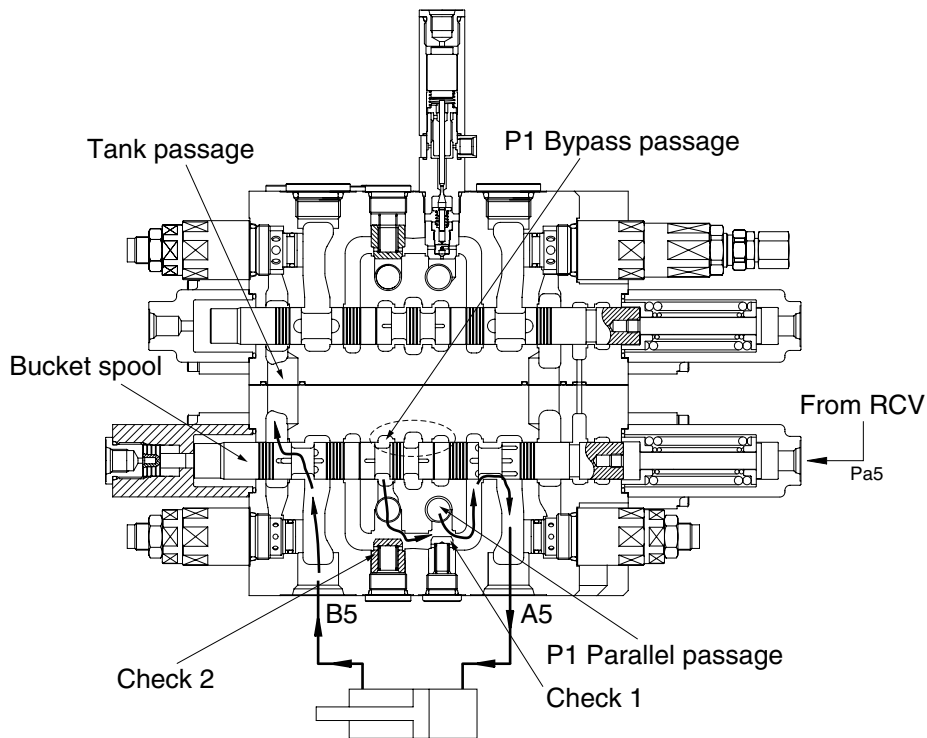

17W92MC34

(2) BUCKET OUT OPERATION

During the bucket out operation, the pilot secondary pressure from RCV is supplied to port Pb5 of the spring opposite side and shifts the bucket spool in the right direction.

The bypass passage is shut off by the movement of the bucket spool and the hydraulic fluid from pump A2 entered P1 parallel passage and is directed to the port B5 through the check 1.

At the same time, the hydraulic fluid from P1 bypass passage is directed to the port B5 through the check 2.

The return flow from the head side of the bucket cylinder returns to the hydraulic oil tank through the port A5 and the tank passage.

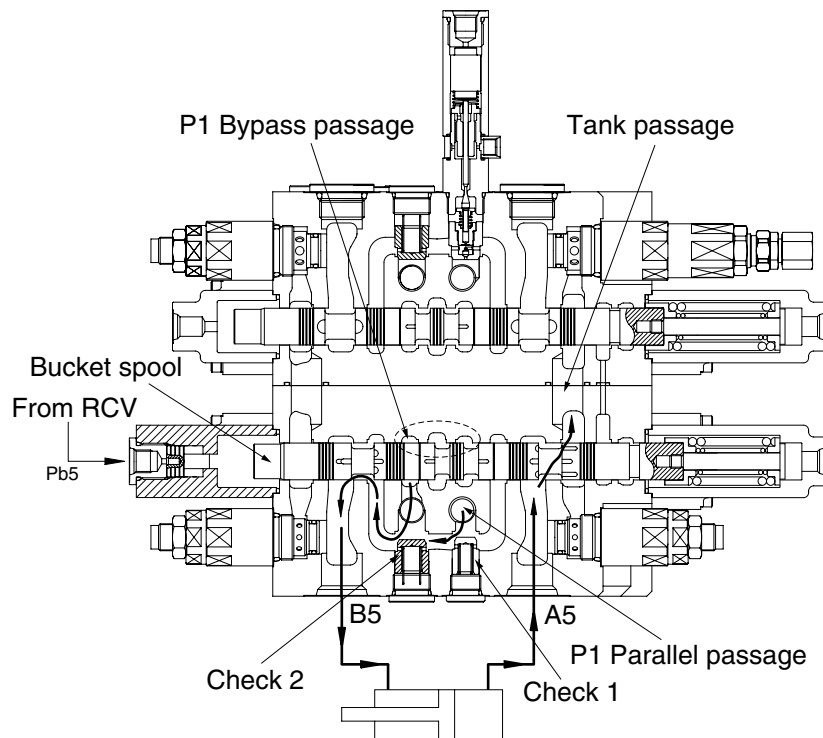

17W92MC35

(3) BUCKET IN OPERATION WITH BOOM OPERATION

When combined operation, mostly same as previous page but the fluid from P1 bypass passage is empty.

So only the fluid from P1 parallel passage is supplied to the bucket cylinder. Also, parallel passage is installed the check 1 for supplying the fluid from pump A2 to the boom operation prior to the bucket operation. In case of the bucket out operation with boom operation, the function is similar.

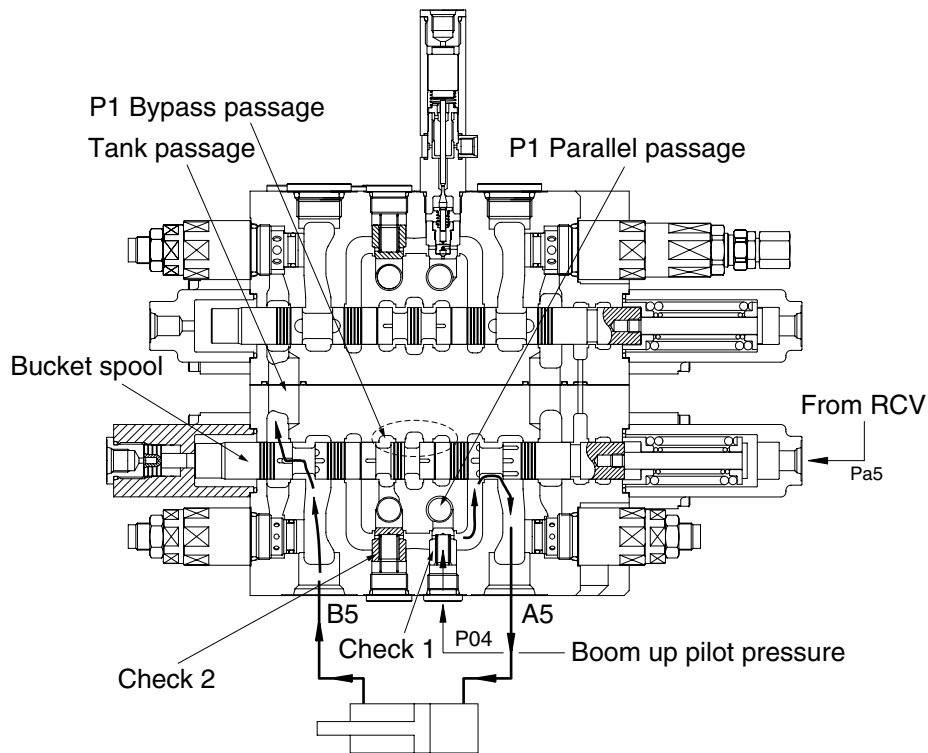

17W92MC29

6) SWING OPERATION

(1) SWING LEFT & RIGHT OPERATION

During the swing left operation, the pilot secondary pressure from the RCV is supplied to the port Pd2 of the spring side and shift the the swing spool in left direction. The bypass passage is shut off by the movement of the swing spool and the hydraulic fluid from pump A1 flows into swing spool through the P2 parallel passage. Then it is directed to swing motor through the port D2.

As the result, swing motor turns and flow from the swing motor returns to the hydraulic oil tank through the port C2, swing spool and the tank passage.

In case of swing right operation, the operation is similar to swing left operation but the pilot secondary pressure from the RCV is supplied to the port Pc2 of the spring opposite side.

Accordingly, the hydraulic fluid from pump A1 flows into swing motor through the port C2 and returns to the hydraulic oil tank through the port D2 and the tank passage.

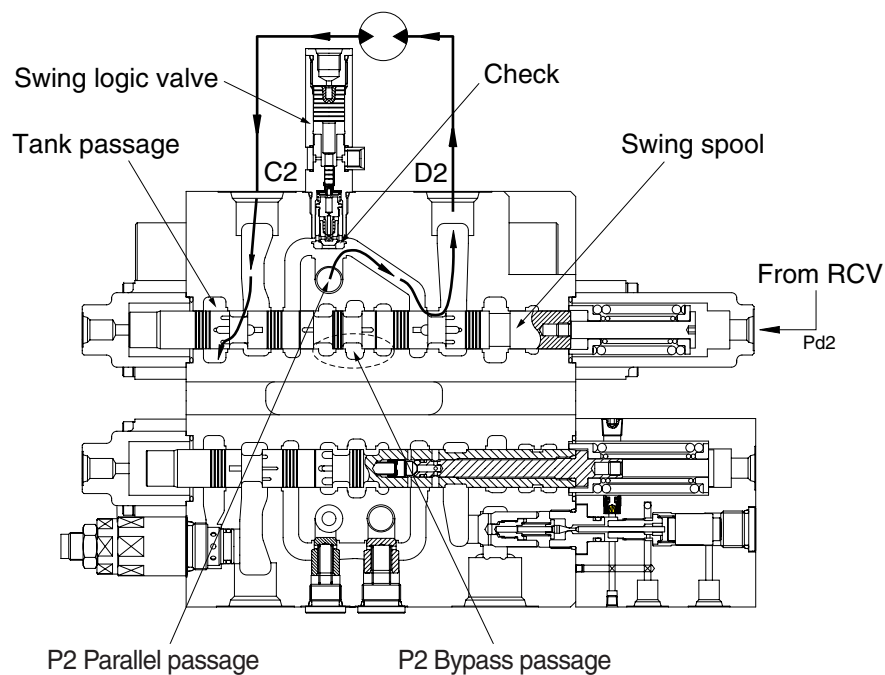

14W92MC32

(2) SWING LEFT OPERATION WITH ARM OR BOOM OPERATION

When combined operation, mostly same as previous page but the fluid from P2 bypass passage is empty.

So only the fluid from parallel passage is supplied to the swing motor. Also, parallel passage is installed the orifice of swing logic valve for supplying the fluid from pump A1 to the boom or the arm operation prior to the swing operation. In case of the swing right operation with arm or boom operation, operation is similar.

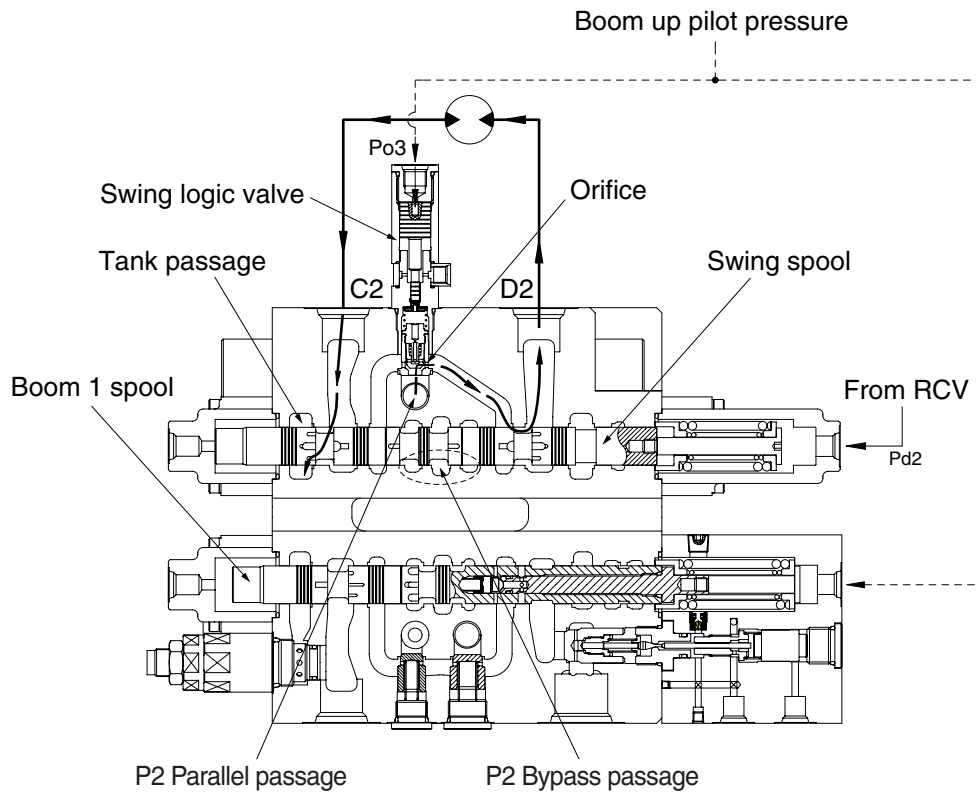

14W92MC20

7) ARM OPERATION

(1) ARM IN OPERATION

During arm in operation, the pilot secondary pressure from the RCV is supplied to the port Pc40 of spring opposite side and shifts arm 1 spool in the right direction.

The bypass passage is shut off by the movement of the arm 1 spool and the hydraulic oil from the pump A1 flows into the arm cylinder head side through P2 parallel passage, the load check valve, bridge passage and the port C4.

At same time, the pilot secondary pressure from the RCV is supplied to the port Pb3 of spring opposite side and shifts arm 2 spool in the right direction. The bypass passage is shut off by the movement of the arm 2 spool and the hydraulic fluid from the pump A2 flows into the arm summation passage through P1 parallel passage, the check valve, the arm 2 spool and the boom 2 spool. Then it entered the arm cylinder head side with hydraulic fluid from arm 1 spool.

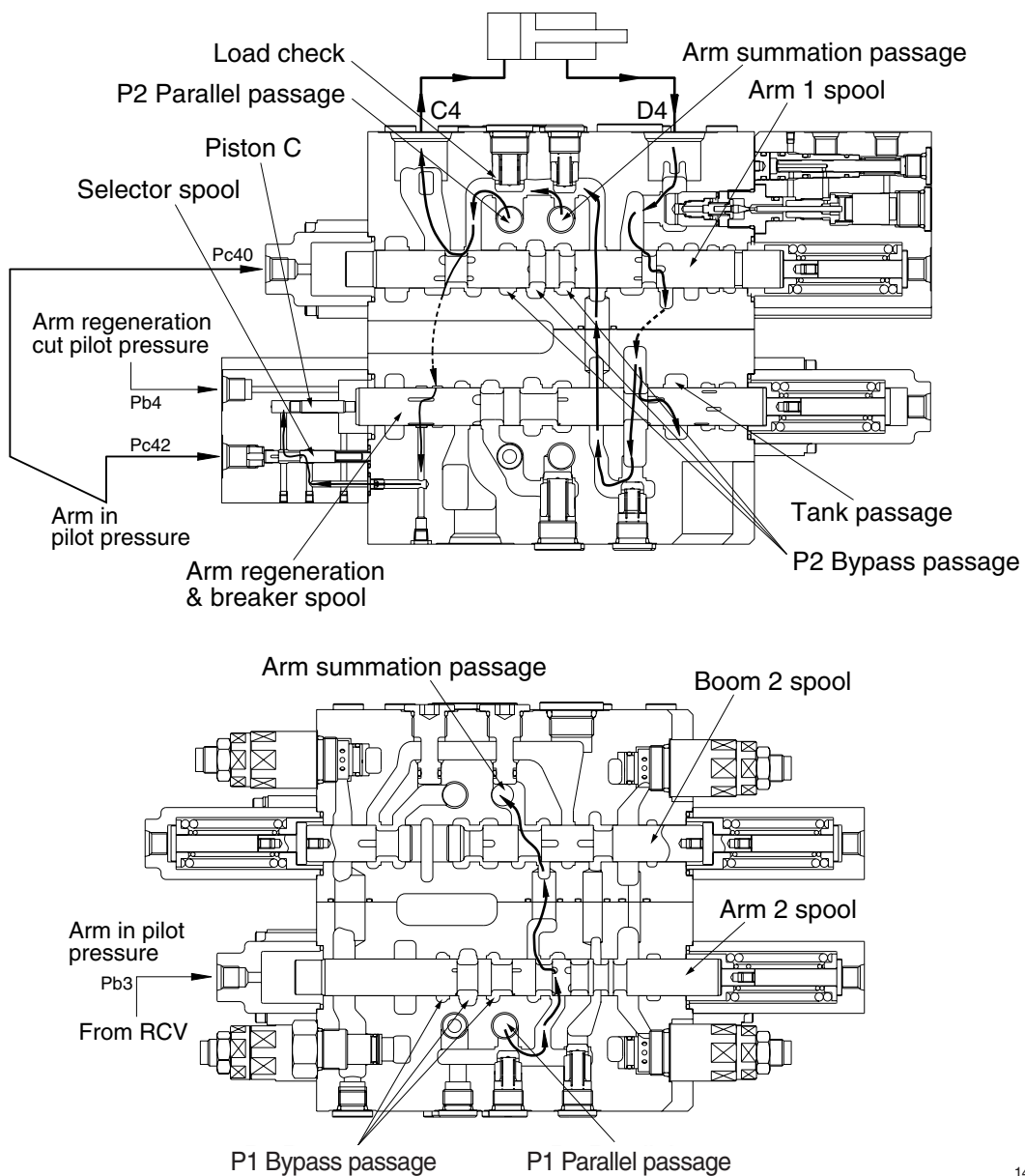

14W92MC21

ARM REGENERATION

The return flow from the arm cylinder rod side is pressurized by self weight of arm and so, returns to port D4. The pressurized oil returning to port D4 enters the arm regeneration & breaker spool through the arm holding valve and the arm 1 spool. It is supplied the arm cylinder head through internal passage. This is called the arm regeneration function.

The amount of regeneration fluid is changed by movement of the arm regeneration spool. A few fluids after P2 parallel passage is push piston "C" through the notch of arm regeneration spool and selector spool. At this time, the selector spool is opened by pilot pressure from RCV.

Then, the arm regeneration spool shifts to right side and flow to tank pass increases and regeneration flow decreases. Therefore, pressure of arm cylinder head increases, then, arm regeneration flow decreases.

Furthermore, the arm regeneration cut pressure is supplied to the port Pb4 of spring opposite side and arm regeneration spool is move into the right direction fully. The flow from the arm cylinder rod is returned to the hydraulic oil tank and regeneration function is not activated. (The return fluid is maximum condition)

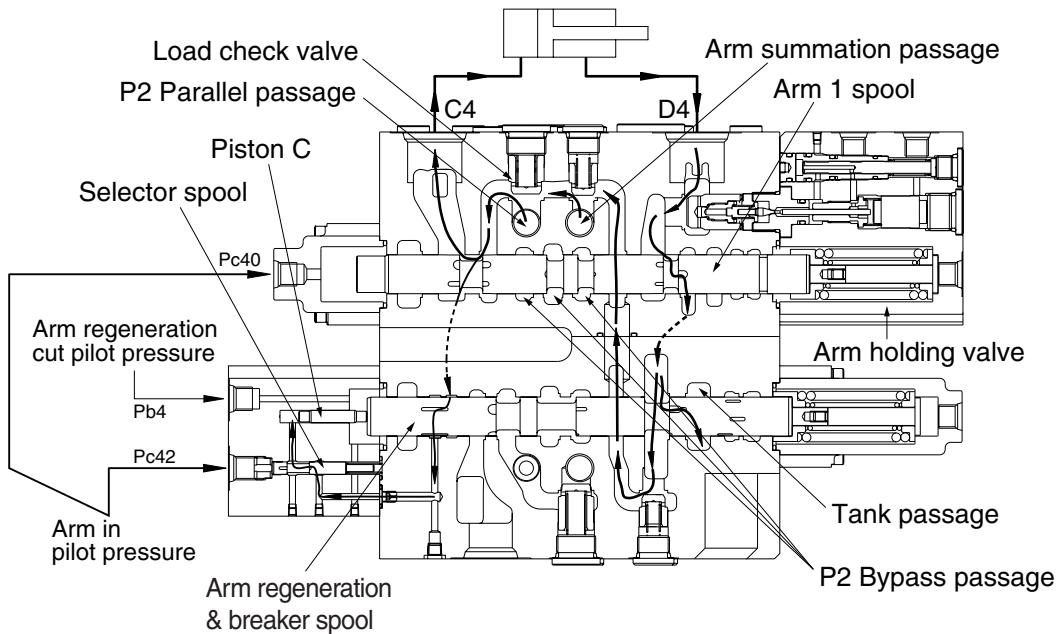

14W92MC22

(2) ARM OUT OPERATION

During arm out operation, the pilot secondary pressure from RCV is supplied to the port Pd40 of spring side and shifts arm 1 spool in the left direction.

The bypass passage is shut off by the movement of the arm 1 spool and the hydraulic fluid from pump A1 flows into arm 1 spool through the P2 parallel passage. Then it enters into the arm cylinder rod side through the load check, bridge passage, arm holding valve and the port D4.

Also, the pilot secondary pressure from RCV is supplied to the port Pd41 of spring side and shifts arm 2 spool in the left direction.

The bypass passage is shut off by the movement of the arm 2 spool and some of the hydraulic fluid from pump A2 bypassed through bypass notch. The rest of hydraulic fluid from pump A2 flows into the arm summation passage through P1 parallel passage, the check valve, arm 2 spool and boom 2 spool.

Then it enters into the arm cylinder rod side with the fluid from the arm 1 spool.

The return flow from the arm cylinder head side returns to the hydraulic tank through the port C4, the arm 1 spool and tank passage.

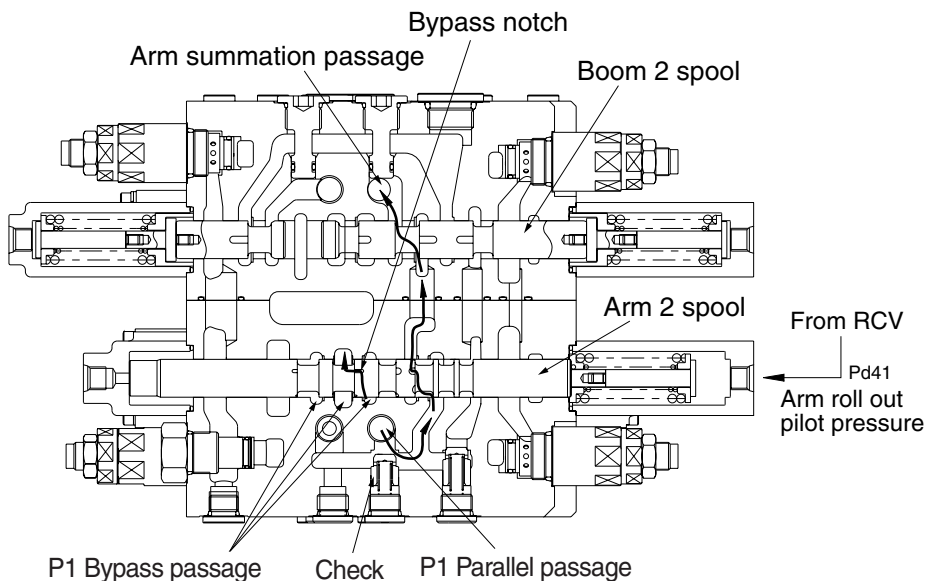
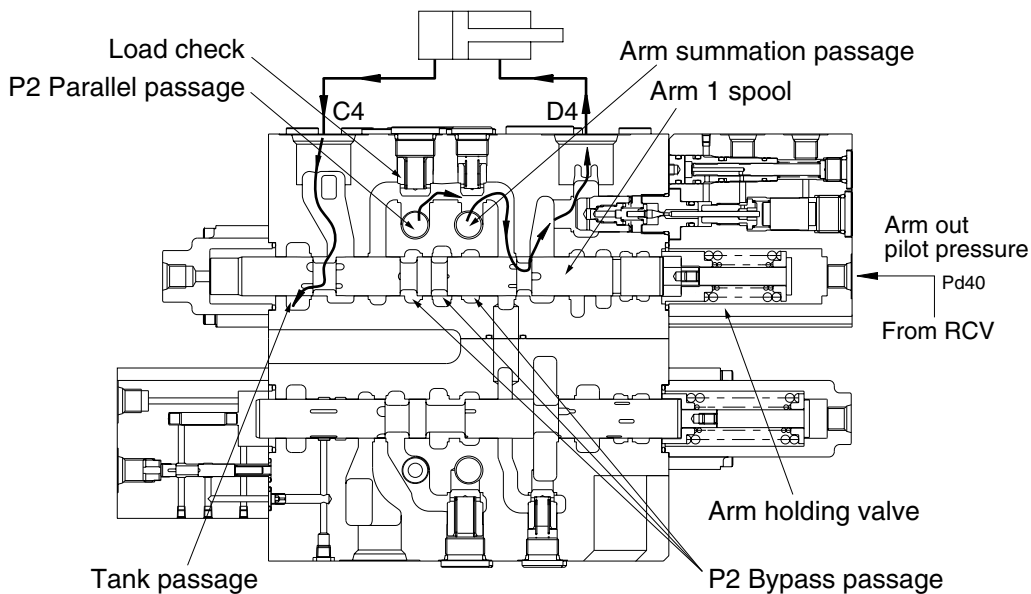

14W92MC23

8) SWING PRIORITY FUNCTION

During swing priority operation, the pilot secondary pressure is supplied to the port Pc3 of the spring side of the swing priority spool and shift swing priority spool in the right direction.

The hydraulic fluid from P2 parallel passage flows into the parallel passage of arm 1 side through swing priority spool and the path "A" and also flows into the boom 2 spool.

When the swing priority spool is neutral condition, the passage is same as normal condition. But due to shifting of the swing priority spool, the fluid from pump A1 flows to swing side more then the boom 2, arm 1, option B and dozer spools to make the swing operation most preferential.

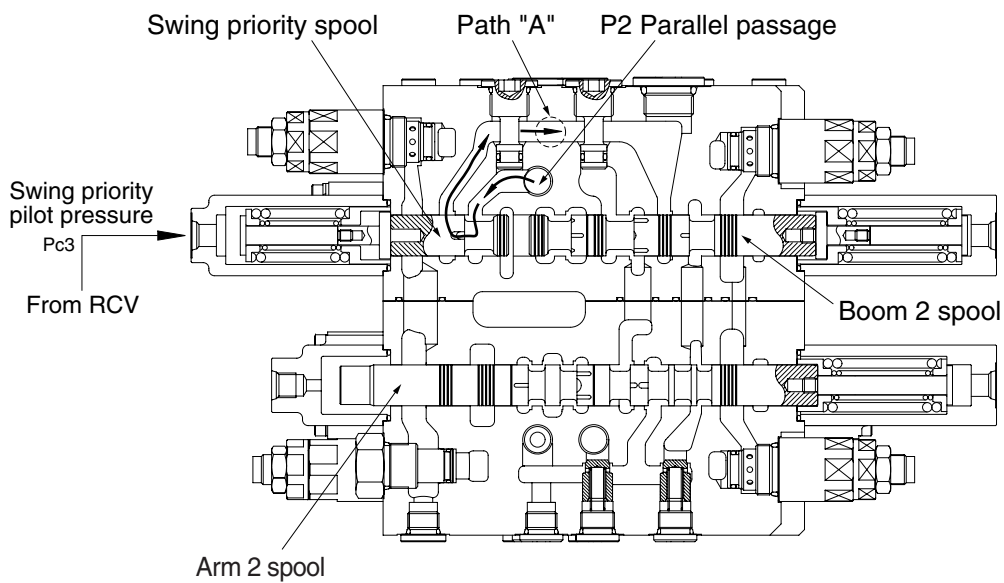

14W92MC27

9) DOZER OPERATION

(1) Dozer down operation

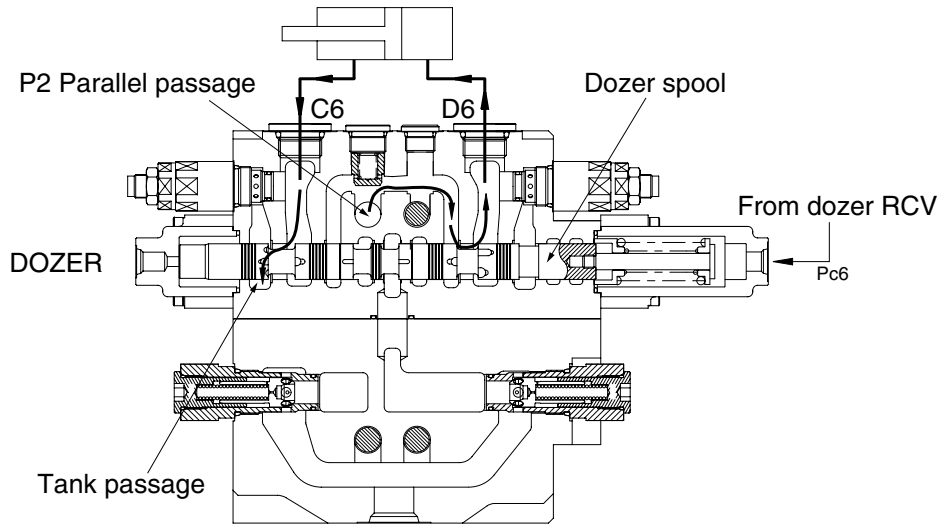

17W92MC30

(2) Dozer up operation

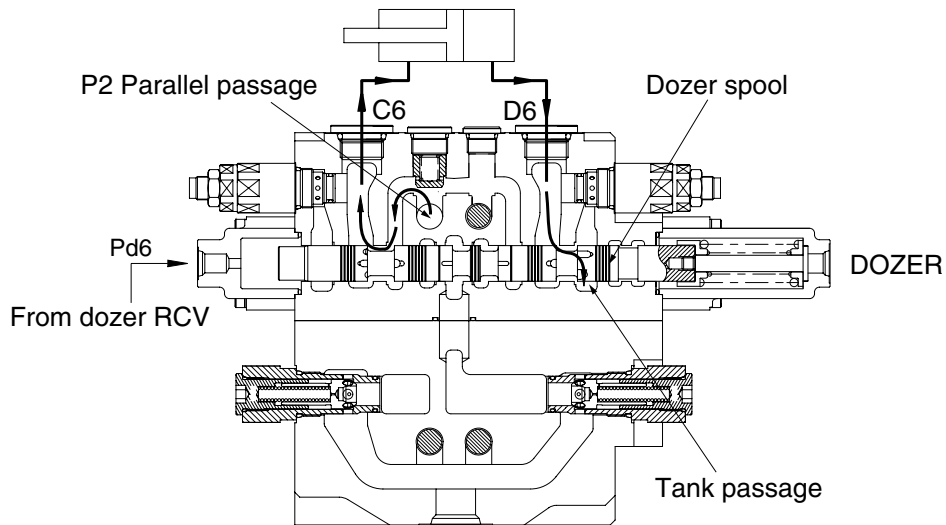

17W92MC31

During the dozer down operation, the pilot pressure from the dozer control valve is supplied into the port Pc6 of the spring side and it shifts the dozer spool in the left direction.

The hydraulic fluid from the pump A1 enters the parallel passage and is direction to the head side of the dozer cylinder through port D6.

The return flow from the rod side of the dozer cylinder returns to the dozer spool through C6 port. Thereafter it is directed to the hydraulic tank through tank passage.

In case of the dozer up operation, operation is similar.

10) NEGATIVE RELIEF VALVE OPERATION

When no function is being actuated on P1 side, the hydraulic fluid from the pump A2, flows into the tank passage through the P1 bypass passage and orifice. The restriction caused by this orifice thereby pressurizes. This pressure is transferred as the negative control signal pressure Pn1 to the pump A2 regulator.

It controls the pump regulator so as to minimize the discharge of the pump A2.

The bypass passage is shut off when the shifting of one or more spools and the flow through bypass passage became zero. The pressure of negative control signal becomes zero and the discharge of the pump A2 becomes maximum.

The negative control pressure reaches to the set level, the hydraulic fluid in the passage pushes open negative control valve and escapes into the return passage.

For the pump A1 the same negative control principle.

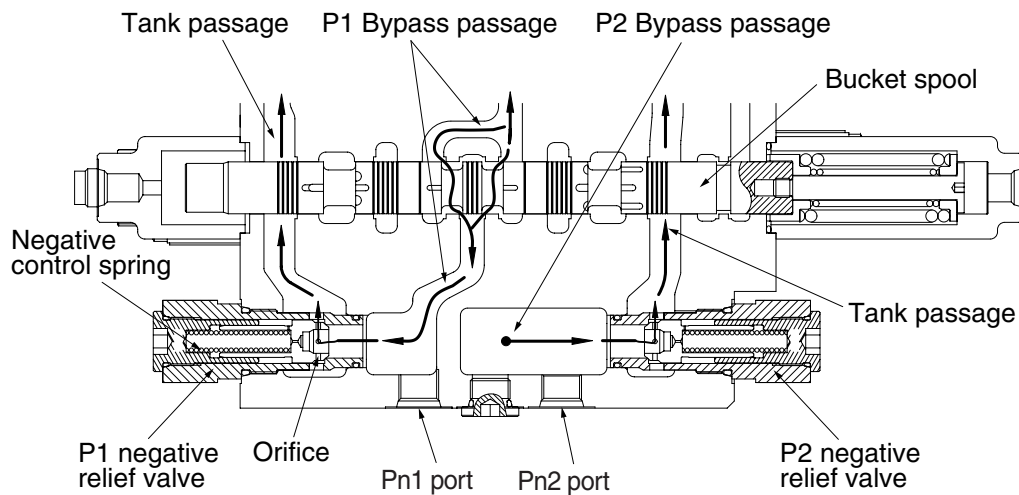

14W92MC28

11) OPERATION OF MAIN RELIEF VALVE

- (1) The pressurized oil passes through the orifice (A) of the plunger is filled up in chamber A of the inside space, and seats the plunger against the housing securely.

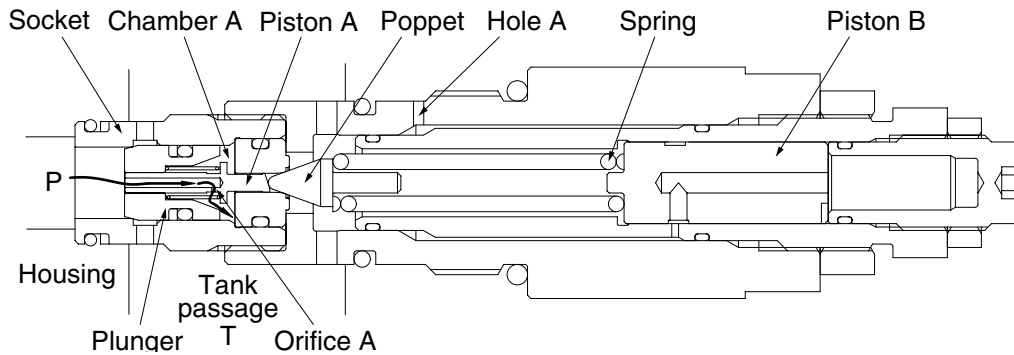

14W92MC36

- (2) When the pressure at (P) becomes equal to the set pressure of the spring the hydraulic oil passes through the piston (A) pushes open the poppet and flows to tank passage (T) through the plunger internal passage, periphery orifice A, chamber A, periphery orifice B and the hole (E).

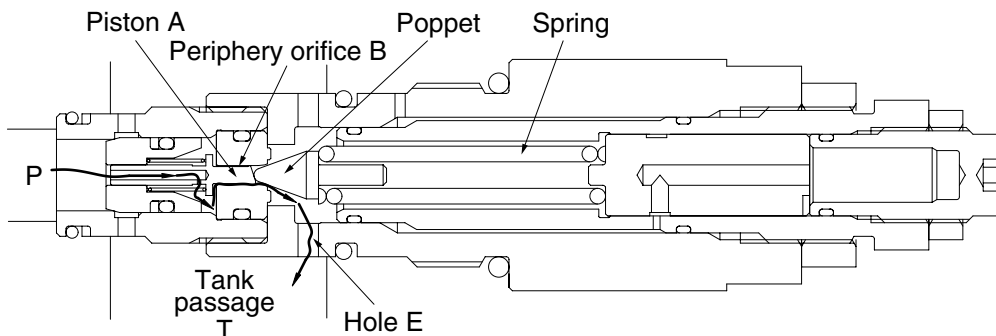

14W92MC37

- (3) Opening the poppet causes the pressure in chamber A to fall and the plunger to open. As the result the pressurized oil at port P runs into tank passage (T).

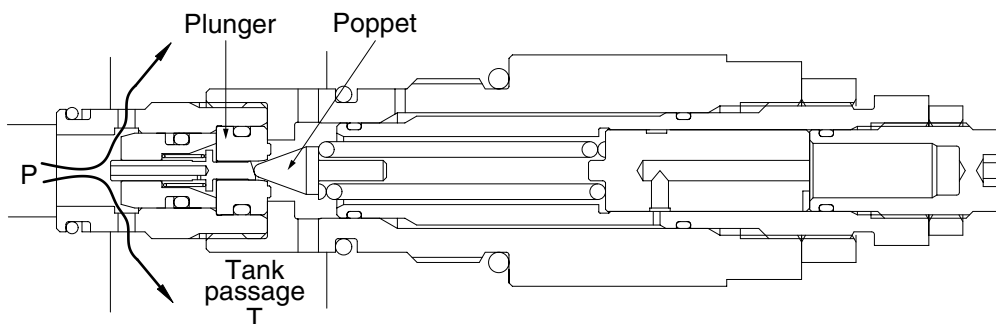

14W92MC38

- (4) The pressure at port P becomes lower than set pressure of the spring, the poppet is seated by spring force. Then the pressure at port P becomes equal to set pressure of the spring and the plunger is seated to the socket.

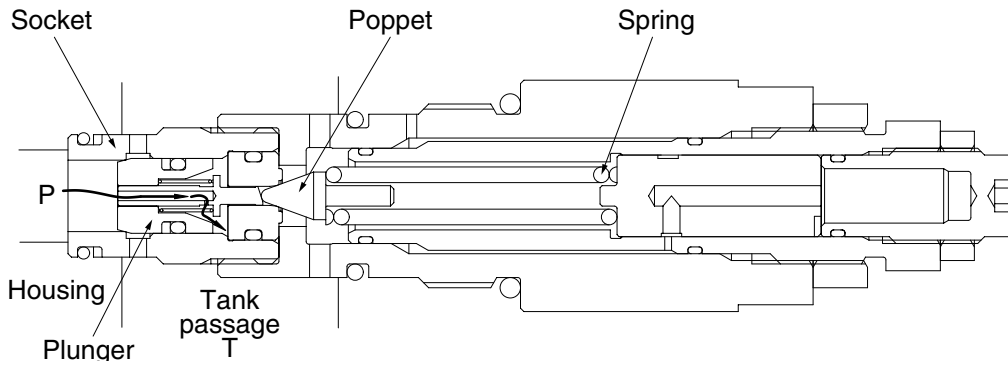

14W92MC39

- (5) When the power boost switch is ON, the pilot pressure enters through hole A. It pushes the piston (B) in the left direction to increase the force of the spring and change the relief set pressure to the high pressure.

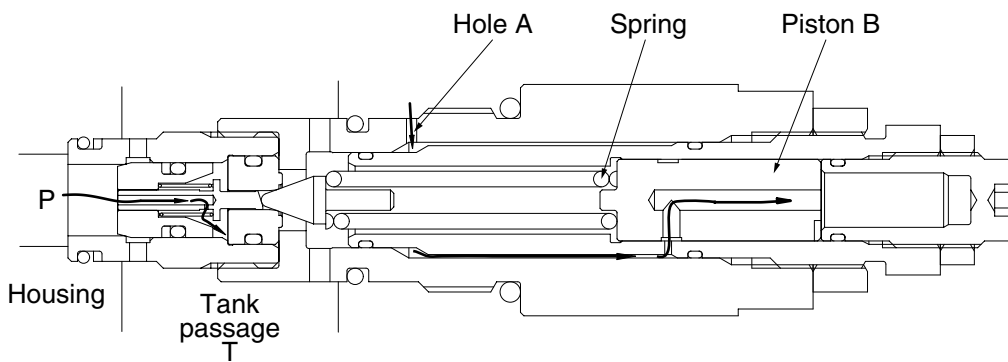

14W92MC40

12) OPERATION OF OVERLOAD RELIEF VALVE

FUNCTION AS RELIEF VALVE

- (1) The pressurized oil passes through the piston A and orifice A is filled up in chamber A of the inside space and seat the plunger against the socket and the socket against the housing securely.

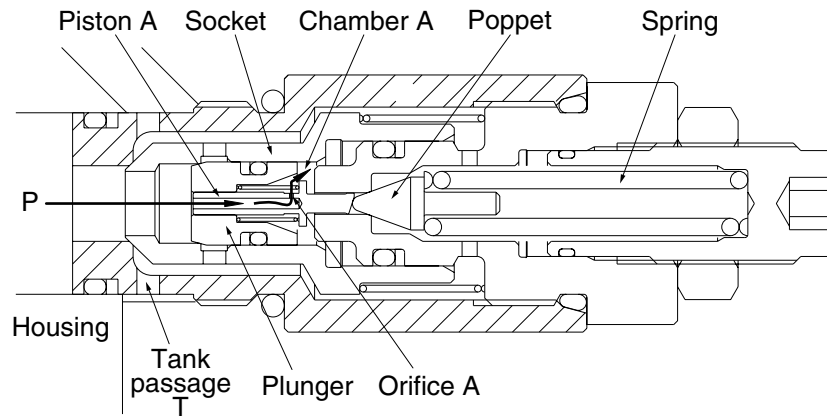

14W92MC41

- (2) When the pressure at port P becomes equal to the set pressure of the spring, the pressurized oil pushes open the poppet and flows to tank passage (T) through the plunger internal passage, orifice A, chamber A, periphery orifice B and hole E.

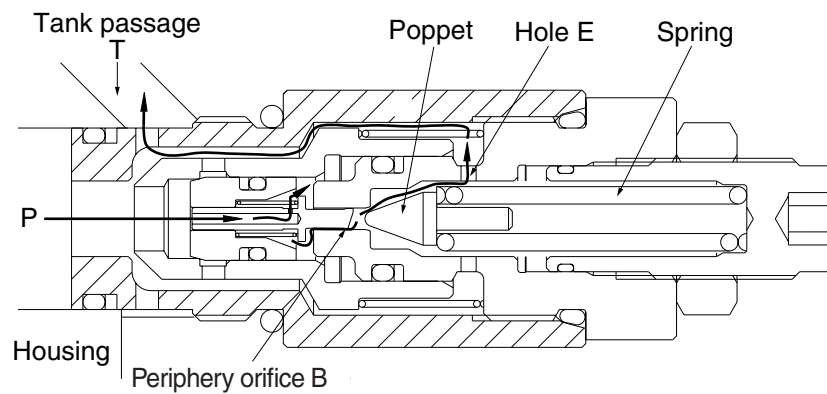

14W92MC42

- (3) Opening of the poppet causes the pressure in chamber A to fall and the plunger to open. As the result the pressurized oil at port P runs into tank passage (T).

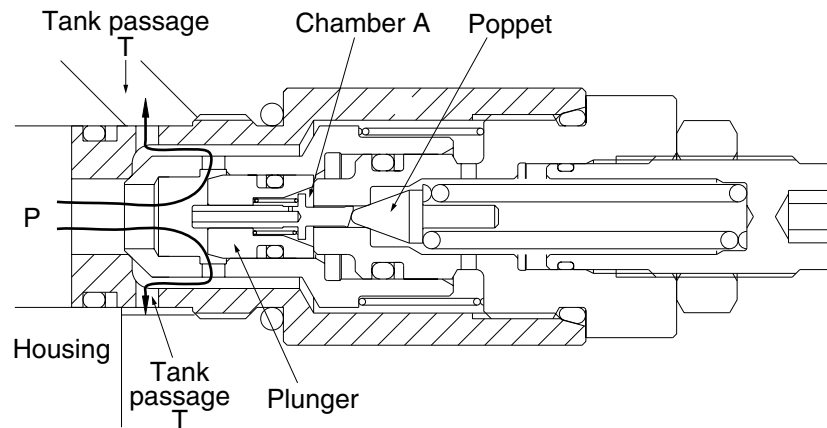

14W92MC43

- (4) The pressure at port P becomes lower than set pressure of the spring, the poppet is seated by spring force. Then the pressure at port P becomes equal to set pressure of the spring and the plunger is seated to the socket.

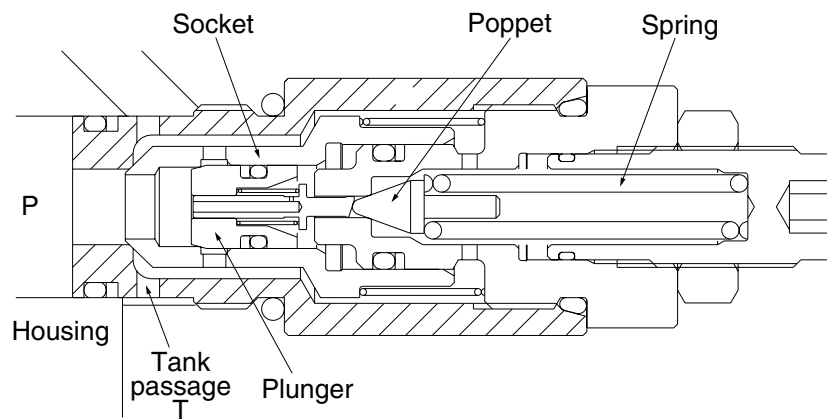

14W92MC44

MAKE-UP FUNCTION

- (5) When negative pressure exists at port P, the oil is supplied through tank passage (T). When the pressure at tank passage (T) becomes higher than that of at port P, the socket moves in the right direction. Then, sufficient oil passes around the socket from tank passage (T) to port P and fills up the space.

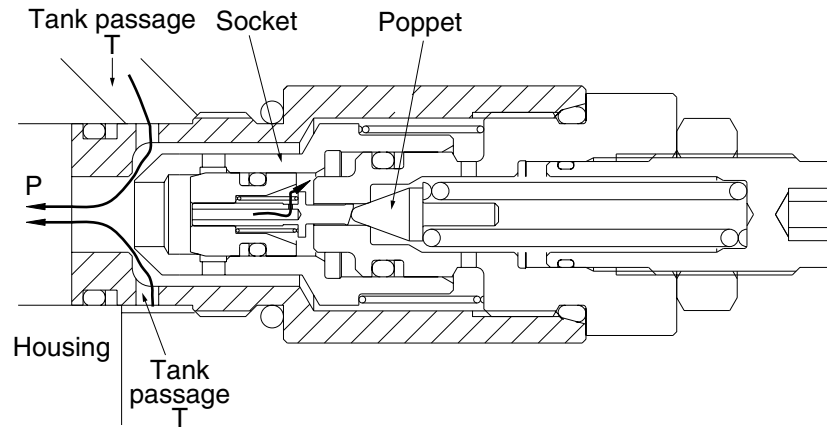

14W92MC45