

## GROUP 9 FRONT AXLE

### 1. REMOVAL FRONT AXLE

- 1) Propeller shaft mounting nut (1, M10)
  - Tightening torque :  $5.9 \pm 0.6 \text{ kgf} \cdot \text{m}$   
( $42.7 \pm 4.3 \text{ lbf} \cdot \text{ft}$ )
- 2) Wheel nut (2, M20)
  - Tightening torque :  $60 \text{ }_{-5}^0 \text{ kgf} \cdot \text{m}$   
( $434 \text{ }_{-36}^{+0} \text{ lbf} \cdot \text{ft}$ )
- 3) Oscillating cylinder supporting mounting bolt (3, M16)
  - Tightening torque :  $29.6 \pm 3.2 \text{ kgf} \cdot \text{m}$   
( $214 \pm 23.1 \text{ lbf} \cdot \text{ft}$ )
- 4) Pipe assy (4)
- 5) Hose assy (5)
- 6) Front axle weight : 630kg (1390lb)

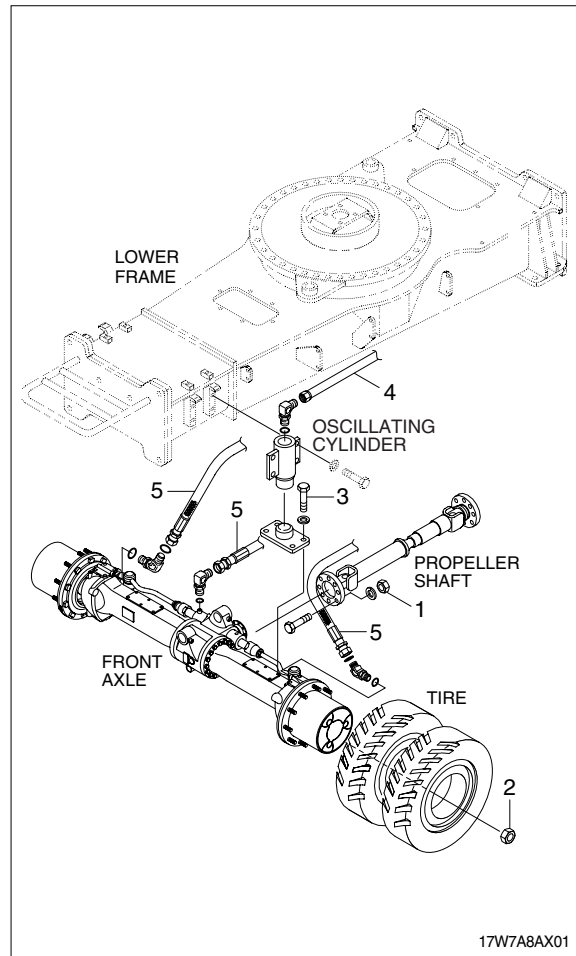

## 2. GENERAL INSTRUCTIONS

### 1) GENERAL WORKING INSTRUCTIONS

- (1) This manual has been developed for the skilled serviceman, trained by the ZF-Passau.
- (2) During all operations, pay attention to cleanliness and skilled working.  
Therefore, axle removed from the machine, must be cleaned prior to open them.
- (3) We assume that the special tools, specified by ZF, will be used.  
The special tools are available from ZF-Passau.
- (4) After the disassembly, all components must be cleansed, especially corners, cavities and recesses of housing and covers.
- (5) The old sealing compound must be carefully removed.
- (6) Check lubricating holes, grooves and pipes for free passage. They must be free of residues, foreign material or protective compounds.
- (7) The latter refers especially to new parts.
- (8) Parts which have been inevitably damaged in a disassembly operation, must be generally replaced by new ones, e.g. rotary seal rings, O-rings, U-section rings, cap boots, protective caps etc..
- (9) Components such as roller bearings, thrust washers, synchronizing parts etc. which are subject to normal wear in automotive operation, must be checked by the skilled Serviceman.  
He will decide if the parts can be reused.
- (10) For the heating of bearings etc., hot plates, rod heaters or heating furnaces must be used.
- (11) Never heat parts directly with the flame. An auxiliary solution would be to immerse the bearing in a vessel filled with oil, which is then heated with the flame.  
In this way, damage to the bearings could be avoided.
- (12) Ball bearings, covers, flanges and parts like that must be heated to about 90 to 100° C.
- (13) Hot-mounted parts must be reset after cooling in order to assure a proper contact.
- (14) Before pressing shafts, bearings etc. in position, both parts must be lubricated.
- (15) During to reassembly, all specified adjustment values, testing specifications and tightening torque must be respected.
- (16) After the repair, units are filled up with oil.
- (17) After the oil filling, the oil level plugs and oil drain plugs must be tightened to the specified tightening torque.

## **2) IMPORTANT INSTRUCTIONS CONCERNING THE LABOUR SAFETY**

- (1) In principle, repairers are themselves responsible for the labour safety.
- (2) The observance of all valid safety regulations and legal rules is a precondition to prevent damage to individuals and products during the maintenance and repair operations.
- (3) Before starting the work, the repairers have to make themselves familiar with these regulations.
- (4) The proper repair of these products requires especially trained personnel.
- (5) The repairer himself is obliged to provide for the training.

## **3) LUBRICANT SPECIFICATIONS**

- (1) Gear oils with limited - slip additives.
- (2) API GL-5
- (3) MIL-L-2105D(SAE 85W-90, 85W-140 with LS-Additive)

#### 4) BRAKE LINING WEARING TEST

(1) The measurement of wear on the multi-disc brake only gives limited information on the total state of the plate pack without disassembling the output.

Make measurement of lining wear at least once per year, in particular, however, in case of a different braking behaviour, like :

- Braking noises
- Reduced braking power
- Different deceleration
- Different brake oil level
- Different braking pressure

※ To avoid injury when opening the oil drain/oil filler plug (1), due to a possible pressure build-up in the planetary carrier bring drain hole to topmost position (12 o'clock) and carefully unscrew oil drain and filler plug (1).

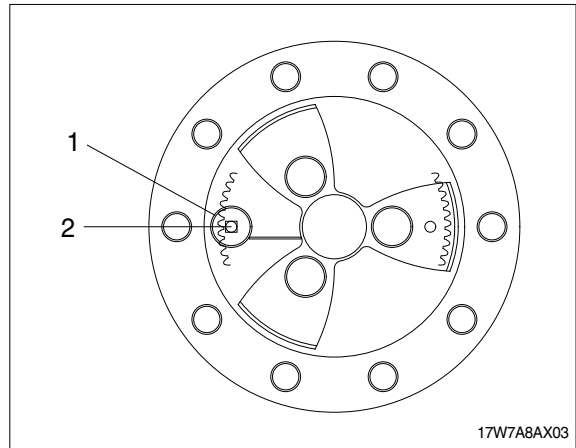

(2) Then turn output until oil filler / oil drain hole (2) is on 9 o'clock position.

1 = Oil filler-/oil drain hole

2 = Gauge hole ( $\varnothing = 10\text{mm}$ ) in ring gear  
9 o'clock position

3 = Dial indicator with solenoid support

4 = Planetary carrier

5 = Ring gear

6 = Piston

7 = Plate pack

X = Piston stroke

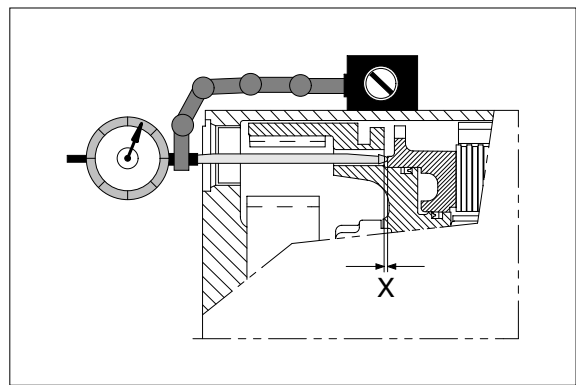
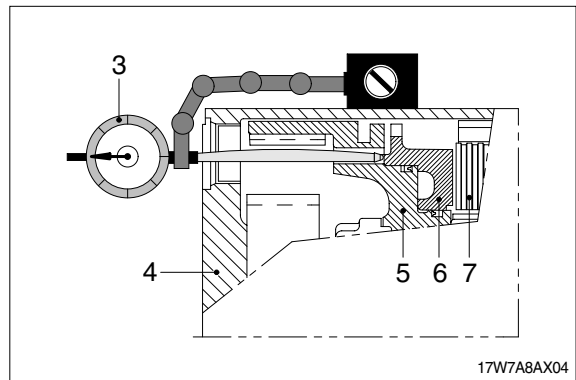

### 3. DISASSEMBLY

Axle installed on assembly truck.

- (S) Assembly truck 5870 350 000
- (S) Support 5870 350 106

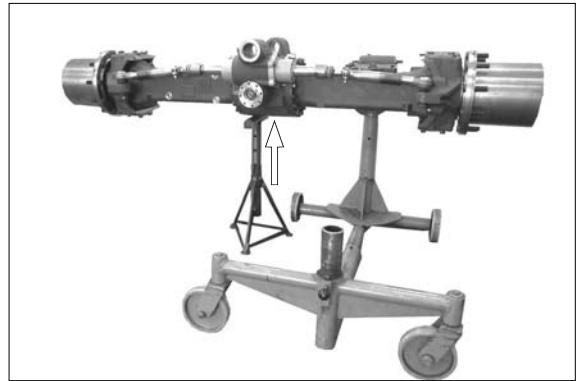

17W7A8FA001

#### 1) STEERING

(1) Steering installed in axle.

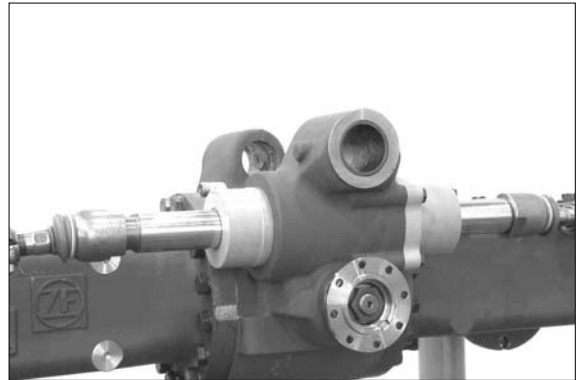

17W7A8FA002

(2) Loosen hex nuts on both tie rods.

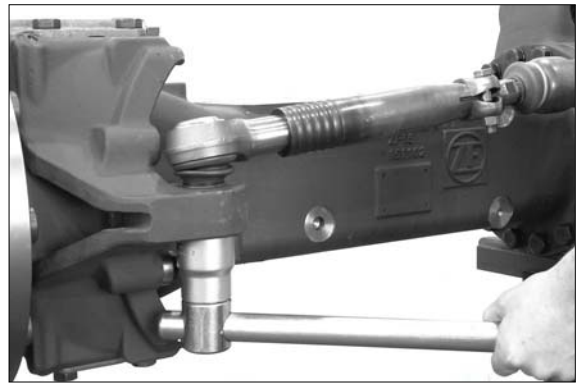

17W7A8FA003

(3) Drive out tie rod from bevel seat

※ Use suitable mandrel (brass / aluminum).

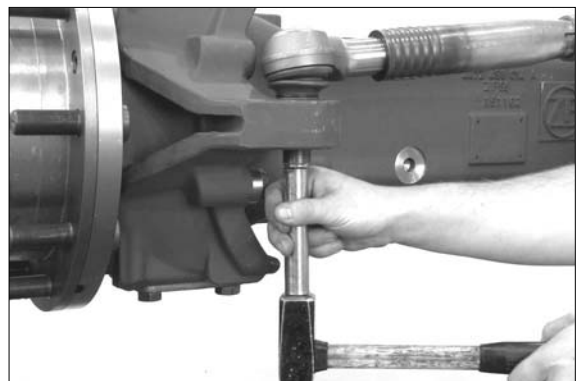

17W7A8FA004

- (4) Warm up threaded joint area of piston rod / axial joint - disassembly is more difficult (thread / axial joint is installed with locking compound / Loctite no. 243).

(S) Hot - air blower 230 V 5870 221 500

(S) Hot - air blower 115 V 5870 221 501

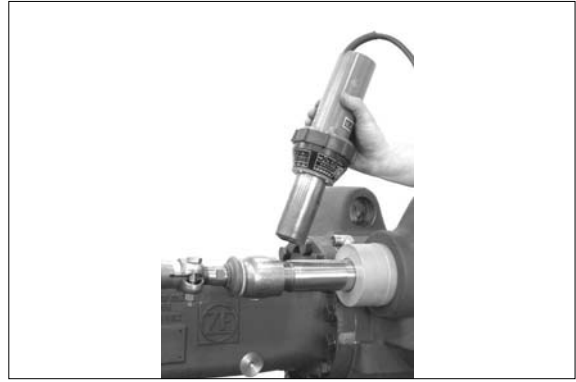

17W7A8FA005

- (5) Separate both tie rods (assy) from piston rod.

※ If work is just to be done on sealing elements and / or piston rod or guide, no disassembly of the steering cylinder assy is required and you may continue with figure FA012.

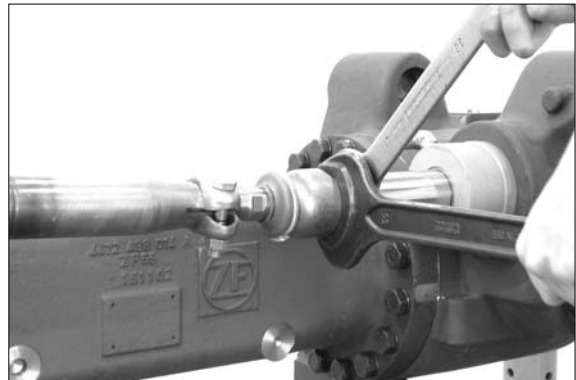

17W7A8FA006

- (6) If required - disassemble both tie rods.

1 = Axial joint

2 = Ball joint with tube

3 = Clamp



17W7A8FA180

- (7) Loosen threaded joint of steering / axle drive housing.

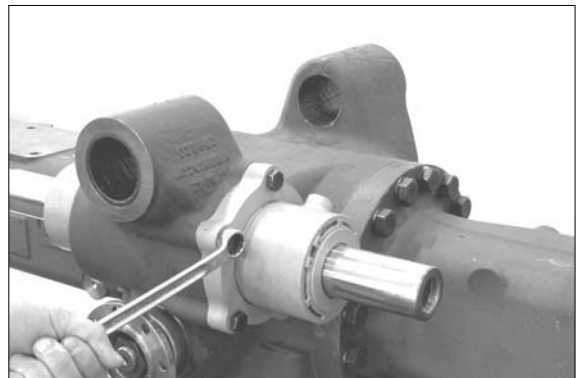

17W7A8FA008

(8) Steering cylinder is fixed with locking compound-disassembly is more difficult.  
Heat up both application areas of locking compound (see arrows) of the axle drive housing by means of a hot - air blower.

(S) Hot-air blower 230 V 5870 221 500

(S) Hot-air blower 115 V 5870 221 501

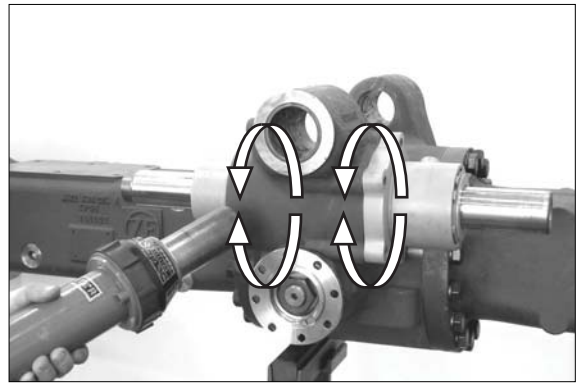

17W7A8FA009

(9) Drive out steering cylinder assy from axle drive housing by means of a plastic / aluminum hammer.

(S) Plastic hammer 5870 280 004

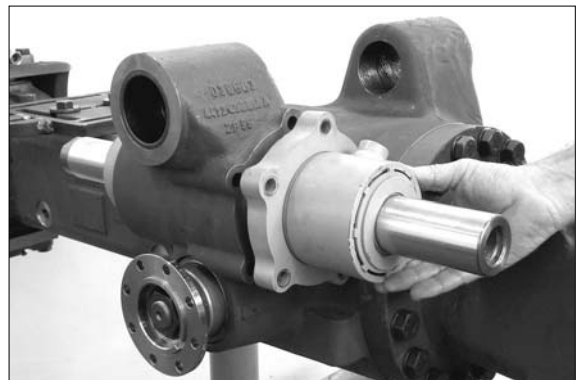

17W7A8FA010

(10) Unsnap the circlip and remove flange.

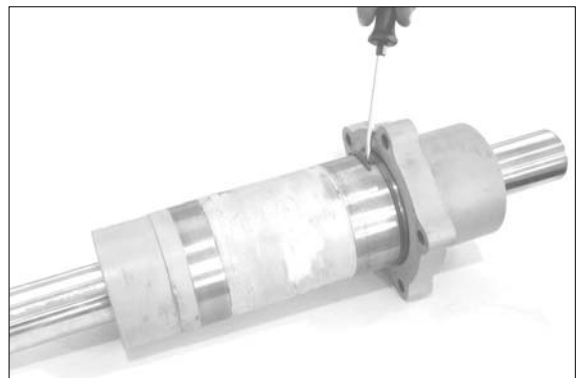

17W7A8FA011

(11) Unsnap retaining ring.

(S) Set of external pliers 5870 900 015



17W7A8FA012

(12) Drive the guide into the cylinder tube (direction of arrow) until the circlip can be removed (see figure FA014).

(S) Plastic hammer 5870 280 003

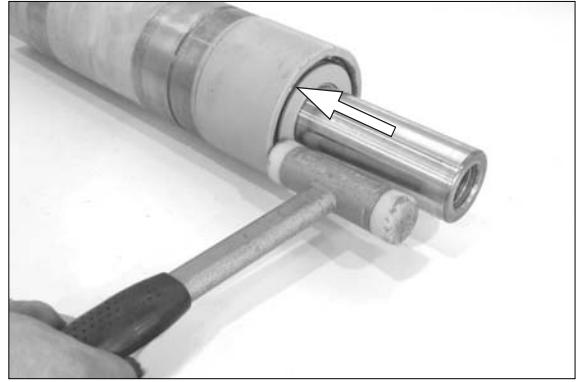

17W7A8FA013

(13) Unsnap circlip.

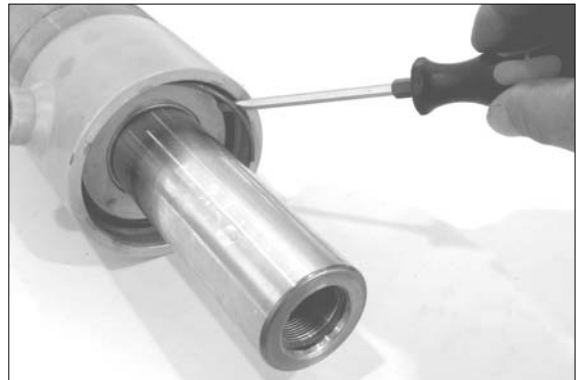

17W7A8FA014

(14) Drive out piston rod together with guide from cylinder tube.

(S) Plastic hammer 5870 280 004

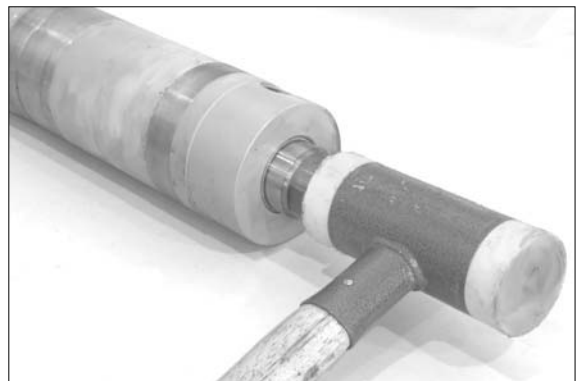

17W7A8FA015

(15) Pull off guide from piston rod.

Remove all sealing elements from piston, guide and cylinder.

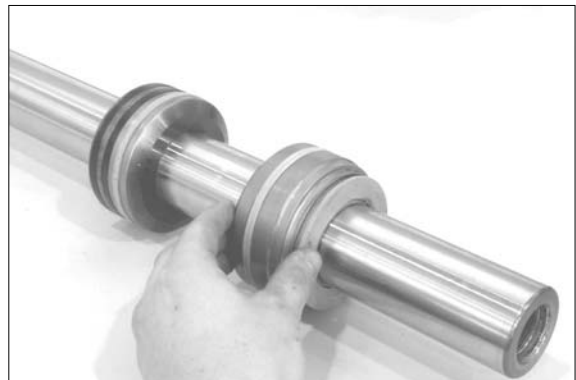

17W7A8FA016

## 2) OUTPUT

(1) Loosen screw plug and drain oil from the axle.

※ Use suitable collecting basin - environmental protection.

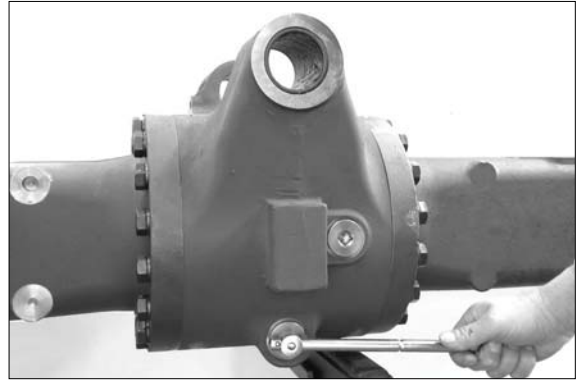

17W7A8FA017

(2) To avoid injury due to a possible pressure build - up in the oil system of the planetary carrier, bring oil filler and control plug to 12 o'clock position and carefully unscrew. Then bring drain hole to 6 o'clock position and drain the oil.

※ Use suitable collecting basin - environmental protection.



17W7A8FA018

(3) Following illustration shows the complete disassembly of the output (figure FA020 ~ FA045) - if work is required on the differential and / or pinion, you may disassemble the output as one unit - as shown on the adjacent photo.

Please take the required work steps (such as dismantling the tie rod - , bearing pins etc. ...) from chapters.

- **Steering**, page 8-174

- **Knuckle housing**, page 8-183.

※ Pay attention to seal ring in the axle housing - risk of damage.

(S) Lifting bracket 5870 281 043

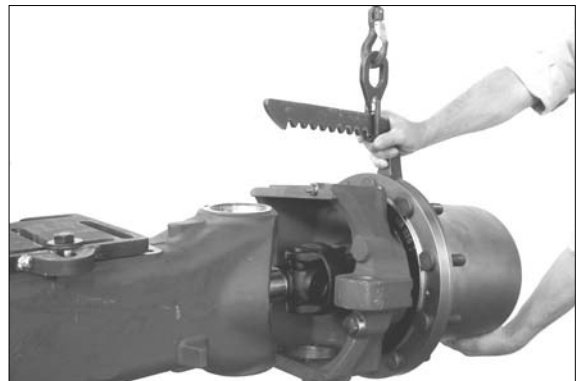

17W7A8FA019

## (4) Planetary carrier

Loosen both cylinder screws and separate planetary carrier from hub.

(S) Lifting strap 5870 281 026



17W7A8FA020

(5) Unsnap circlip.

(S) Set of external pliers 5870 900 015

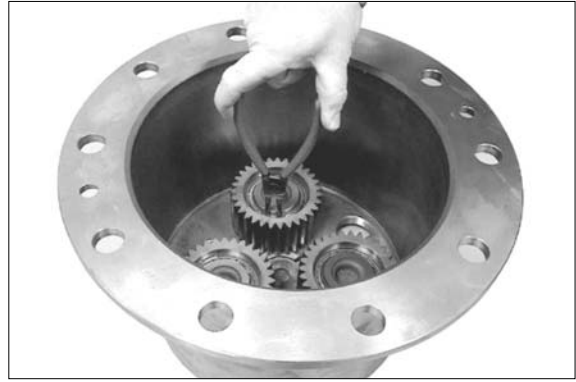

17W7A8FA021

(6) Pull off planetary gear by means of a two-armed puller.

(S) Two-armed puller 5870 970 002

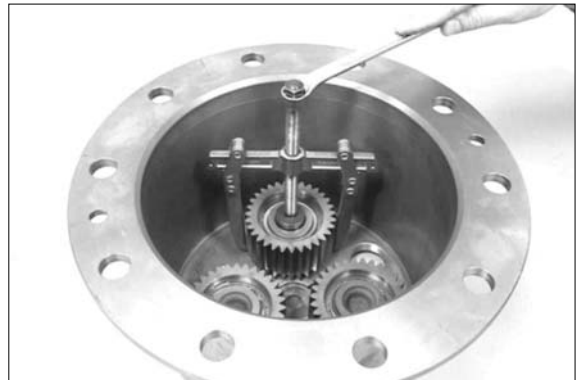

17W7A8FA022

(7) Unsnap circlip and remove washer.

Then remove roller bearing, second circlip and washer from planetary gear.

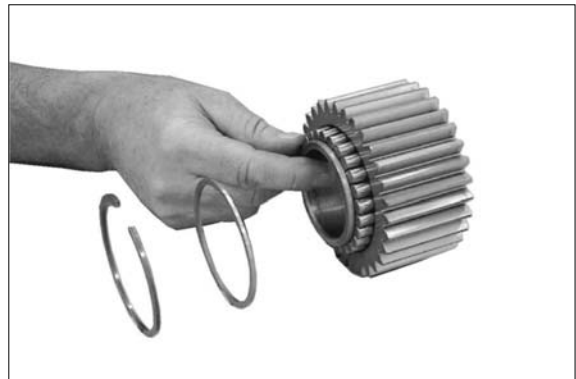

17W7A8FA023

**(8) Brake / hub**

Unsnap retaining ring and remove both thrust washers.

(S) Set of external pliers 5870 900 015



17W7A8FA024

(9) Remove slotted nut mount (cylinder screw).

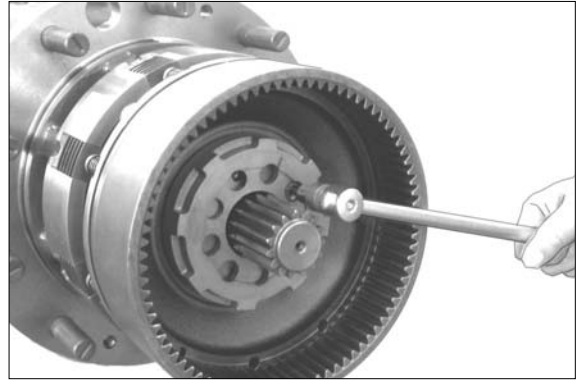

17W7A8FA025

(10) Loosen slotted nut.

(S) Slotted nut wrench 5870 656 097



17W7A8FA026

(11) Press off ring gear with piston.  
Pay attention to the releasing O-ring  
(arrow).

(S) Assembly lever 5870 345 065

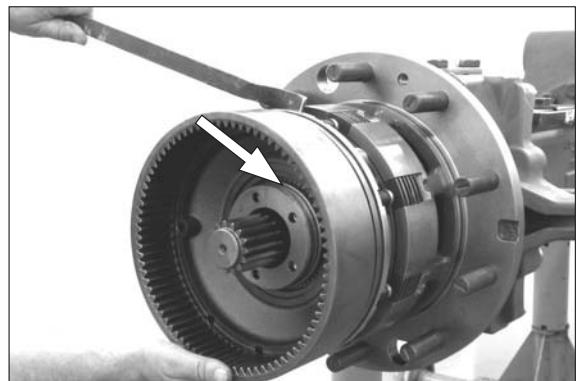

17W7A8FA027

(12) Loosen hex. screws, remove spring sleeves and compression springs.



17W7A8FA028

(13) Press off piston from ring gear.



17W7A8FA029

(14) Remove sealing elements (arrows) from ring gear.

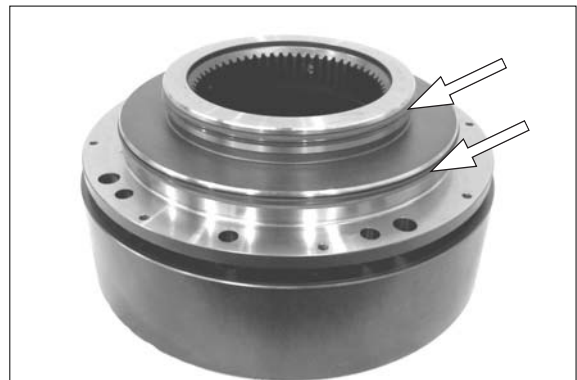

17W7A8FA030

(15) Remove plate pack.

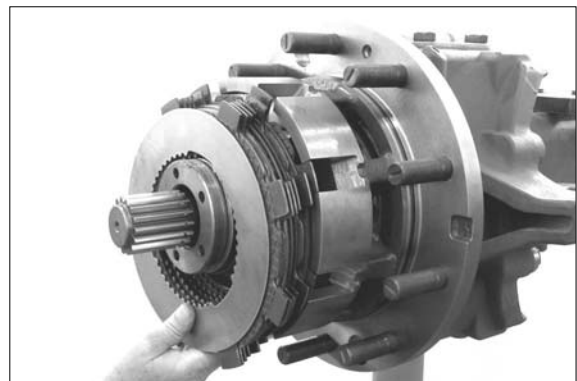

17W7A8FA031

(16) Remove O-ring (arrow) and lift - off disc carrier with lever, then remove releasing O-ring.

(S) Adjusting device            5870 400 001  
(2 pcs. required)



17W7A8FA032

(17) Pull hub from hub carrier by means of pressure piece and two-armed puller.

Pay attention to the releasing bearing inner ring.

- (S) Two-armed puller 5870 970 028
- (S) Pressure piece 5870 100 067
- (S) Lifting bracket 5870 281 043

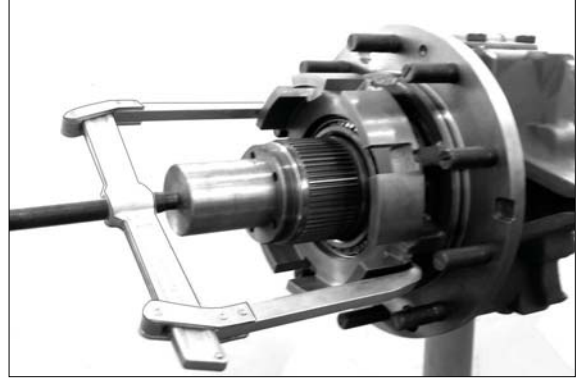

17W7A8FA033

(18) Lift-off shaft seal (arrow) with lever and remove both bearing outer rings from hub.

- (S) Pry bar 5870 345 071

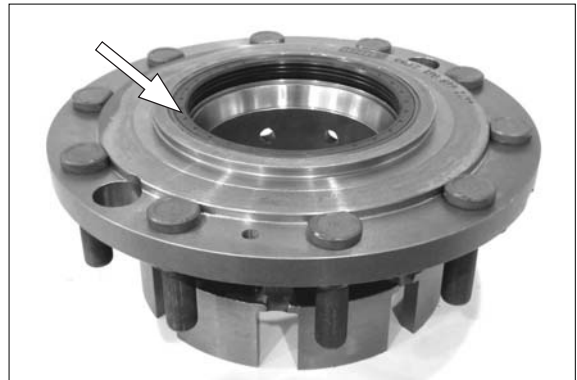

17W7A8FA034

(19) Remove spacer bushing.

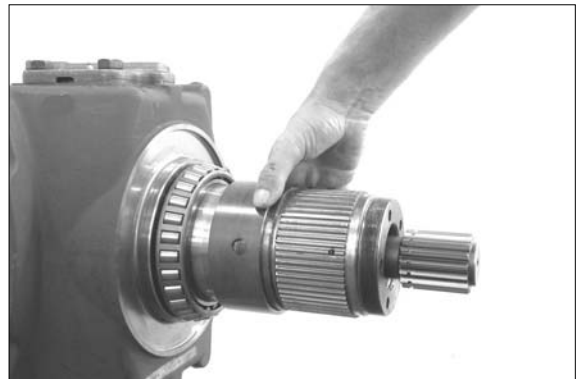

17W7A8FA035

(20) Pull bearing inner ring from hub.

- (S) Gripping insert 5873 004 026
- (S) Two-armed puller 5870 970 028
- (S) Pressure piece 5870 100 067

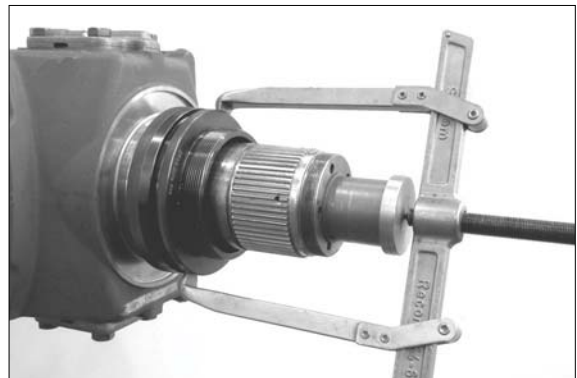

17W7A8FA036

## (21) Knuckle housing

- 1 = Bearing pin
- 2 = Knuckle housing
- 3 = Axle housing
- 4 = Shim (only on lower bearing pin)
- 5 = O-ring
- 6 = Sealing cap
- 7 = Taper roller bearing

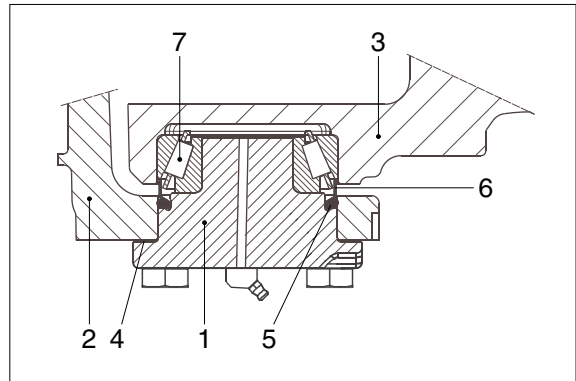

17W7A8FA037

(22) Loosen threaded connection and remove upper bearing pin.

- ※ Remove lower bearing pin - by means of lifting device / see figure FA039 - not before securing the knuckle housing.

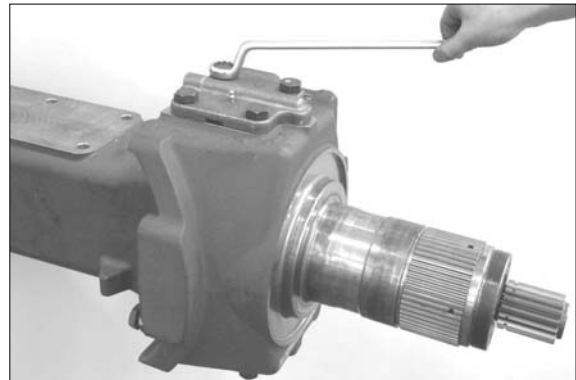

17W7A8FA038

(23) Secure knuckle housing by means of lifting device and dismantle lower bearing pin.

- ※ Pay attention to releasing shim.

(S) Lifting chain                    5870 281 047  
    2 Eyebolt M16                0636 804 001

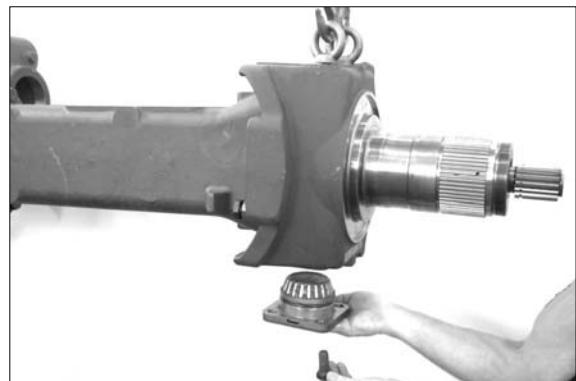

17W7A8FA039

(20) Remove bearing inner ring (7), O-ring (5), sealing cap (6) and brake connection screw neck (8) from bearing pin (1).

(S) Gripping insert                5873 001 030  
in connection with  
back off insert                    5870 026 100

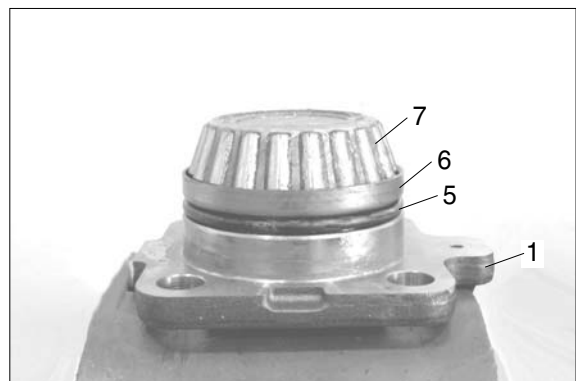

17W7A8FA040

(21) Separate knuckle housing with double u-joint shaft from axle housing.

※ Pay attention to seal ring in the axle housing - risk of damage.

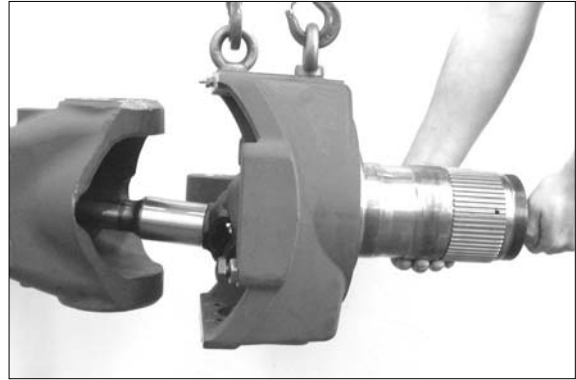

17W7A8FA041

(22) Pull out double u-joint shaft from knuckle housing.

※ Pay attention to seal ring in the axle housing - risk of damage.

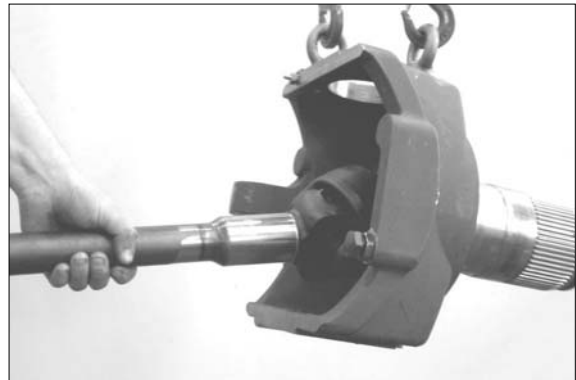

17W7A8FA042

(23) Pull out seal ring and afterwards the bushing behind from the knuckle housing.

(S) Internal extractor 5870 300 017

(S) Counter support 5870 300 020



17W7A8FA043

(24) Pull out seal ring and afterwards the bushing behind from the axle housing.

(S) Internal extractor 5870 300 017

(S) Counter support 5870 300 020

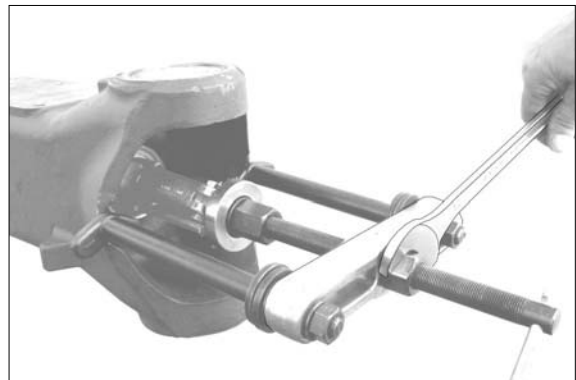

17W7A8FA044

(25) Pull out both bearing outer rings from the swivel bearing holes.

(S) Internal extractor 5870 300 019

(S) Counter support 5870 300 020

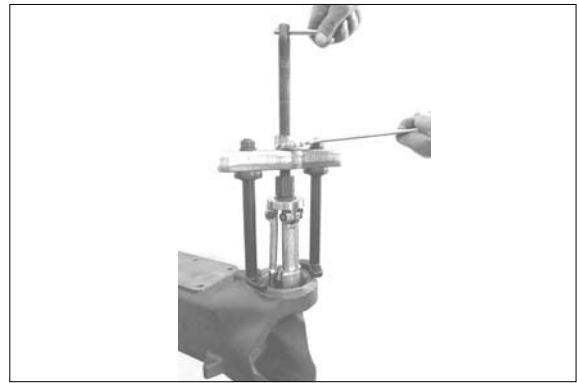

17W7A8FA045

### 3) DIFFERENTIAL - INPUT

(1) If work is required on the differential and / or pinion, you may disassemble the output (s) as one unit - as shown on the adjacent photo.

Please take the required work steps (such as dismantling the tie rod -, bearing pins etc. ...) from chapters

- **Steering**, page 8-174

- **Knuckle housing**, page 8-183

※ Pay attention to the seal ring in the axle housing - risk of damage.

(S) Lifting bracket 5870 281 043

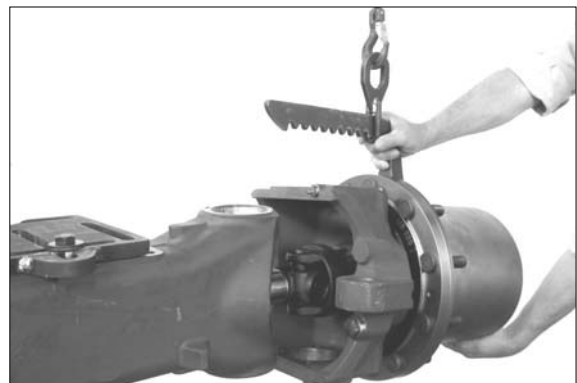

17W7A8FA046

(2) Fix axle housing by means of a lifting strap, loosen threaded joint of axle housing half on crown wheel side (differential) and separate axle housing half from axle drive housing.

※ Pay attention to the releasing differential.

(S) Lifting strap 5870 281 026

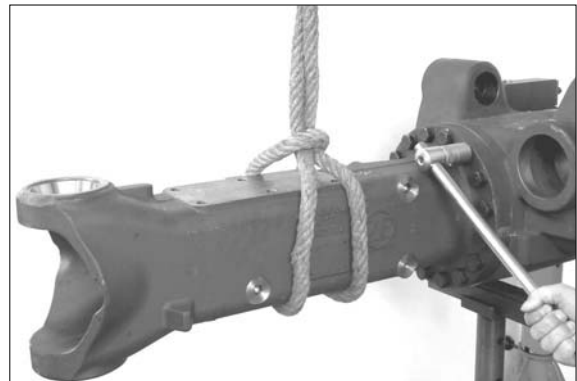

17W7A8FA047

(3) Remove bearing outer ring (arrow 1) and the shim behind as well as O-ring (arrow 2) from axle housing.

※ Mark shim (regarding position/bearing allocation) - assembly aid.

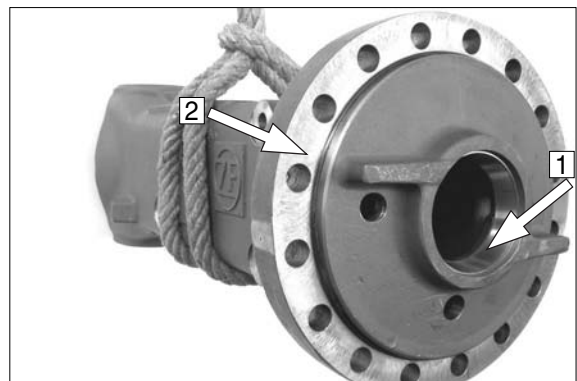

17W7A8FA048

- (4) Lift off the differential from the axle drive housing.

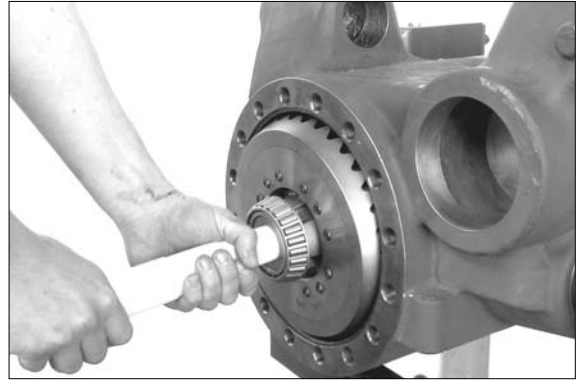

17W7A8FA049

- (5) Pull out bearing outer ring and the shim behind from the bearing hole of axle housing.

※ Mark shim (regarding position / bearing allocation) - assembly aid.

(S) Striker 5870 650 004

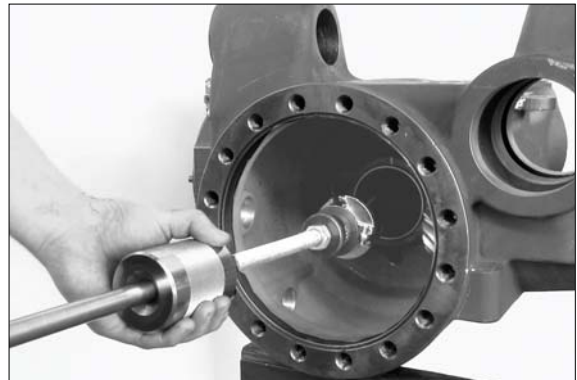

17W7A8FA050

**(6) Differential**

Pull both taper roller bearings from differential carrier.

(S) Gripping insert Super 5873 001 020

(S) Back - off insert 5870 026 100

(S) Pressure piece 5870 100 009



17W7A8FA051

- (7) Loosen threaded joint (position X).

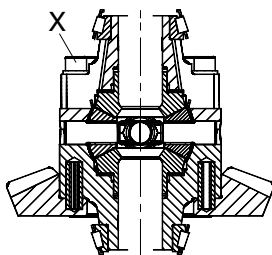

17W7A8FA052

- (8) Separate differential carrier halves and remove the releasing single components.



17W7A8FA053

- (9) Press off crown wheel from differential carrier half.

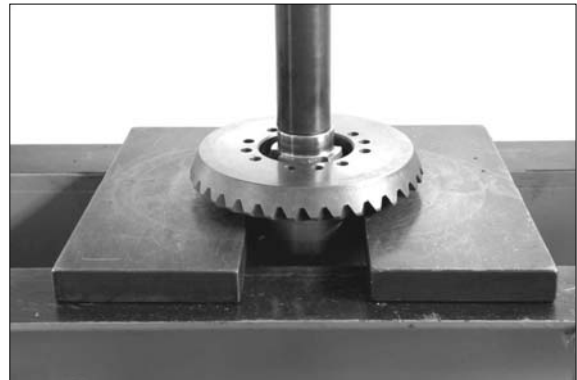

17W7A8FA054

**(10) Input**

- 1 = Input pinion
- 2 = Hex. nut
- 3 = Washer
- 4 = Input flange
- 5 = Screen sheet
- 6 = Seal ring
- 7 = Taper roller bearing
- 8 = Spacer ring(bearing rolling moment)
- 9 = Shim(contact pattern)
- 10 = Input housing

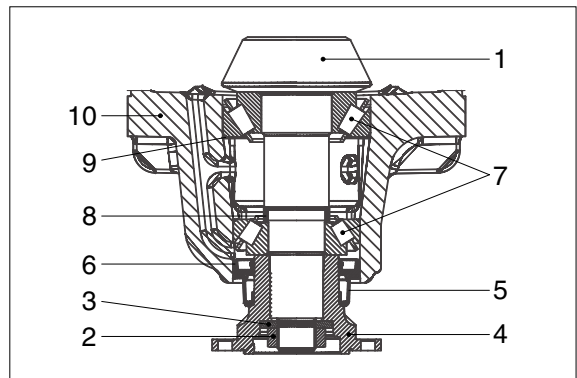

17W7A8RA075

- (11) Loosen hex. nut and remove the washer behind.

※ Pay attention to support of axle housing (arrow).

(S) Fixture 5870 240 025

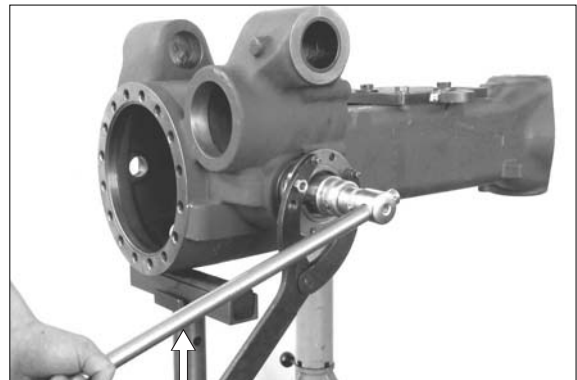

17W7A8FA056

(12) Remove flange.

If required - remove screen sheet from output flange.

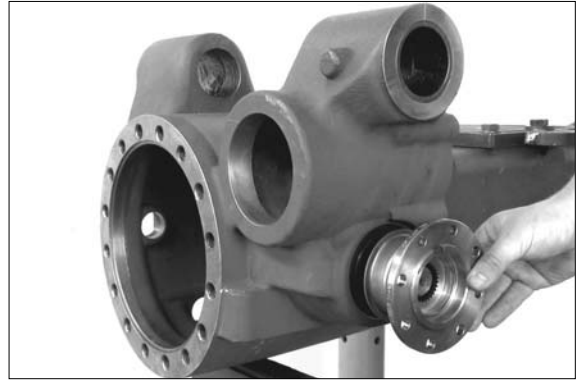

17W7A8FA057

(13) Lift-off seal ring with lever.

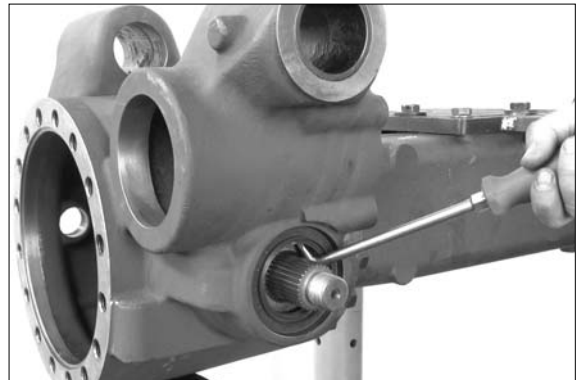

17W7A8FA058

(14) Drive out input pinion.

※ If taper roller bearings should not be replaced, pay attention that the outside bearing inner ring - with all its rolls - is in contact with bearing outer ring when driving out the input pinion.

(S) Plastic hammer            5870 280 004



17W7A8FA059

(15) Remove spacer ring.



17W7A8FA060

(16) Press off bearing inner ring from input pinion.

(S) Gripping insert            5873 001 037



17W7A8FA061

(17) Extract outside bearing outer ring.

(S) Internal extractor            5870 300 019

(S) Counter support            5870 300 020

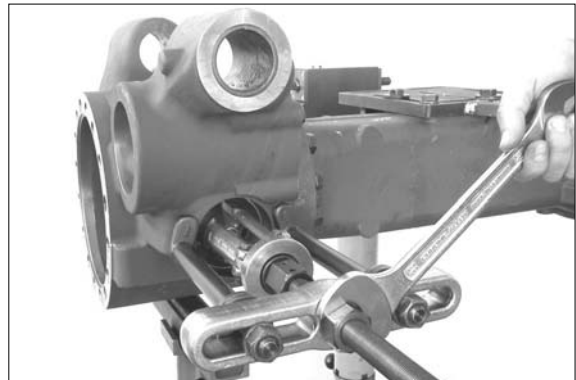

17W7A8FA062

(18) Drive out bearing outer ring from the inner bearing hole - pay attention to the shim behind.

※ Mark shim (reg. position / bearing allocation) - assembly aid.

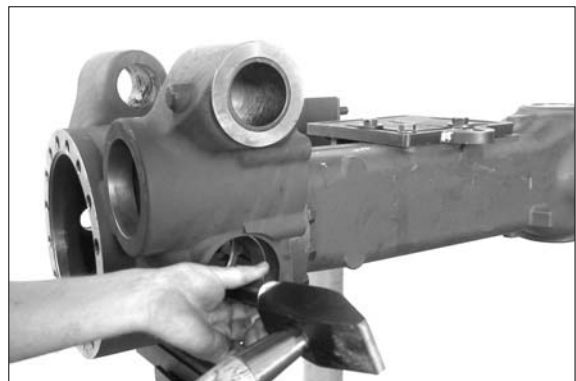

17W7A8FA063

#### 4) PIVOT BEARING

If required :

Provide bushings with a separating slot - see arrow - (bushings are destroyed by this).

Then remove bushings from holes.

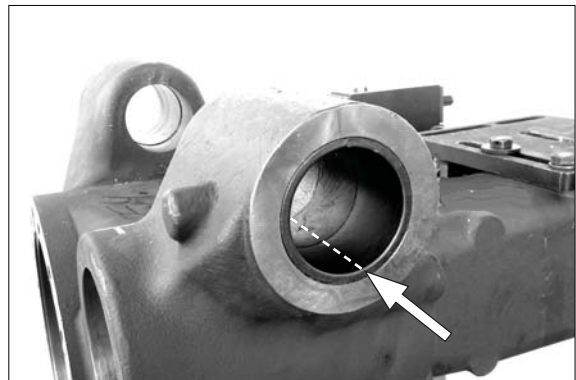

17W7A8FA064

## 2. REASSEMBLY

### 1) INPUT

(1) Comment on sketch :

- 1 = Drive pinion
- 2 = Differential (with crown wheel)
- 3 = Shim for contact pattern (bevel gear set)
- 4 = Spacer ring  
(Bearing rolling moment / pinion bearing)
- 5 = Shim for backlash
- 6 = Shim (bearing rolling moment / differential bearing)
- 7 = Input flange
- 8 = Seal ring
- 9 = Axle drive housing
- 10 = Axle housing
- 10a = O-ring
- 11 = Axle housing (crown wheel side)

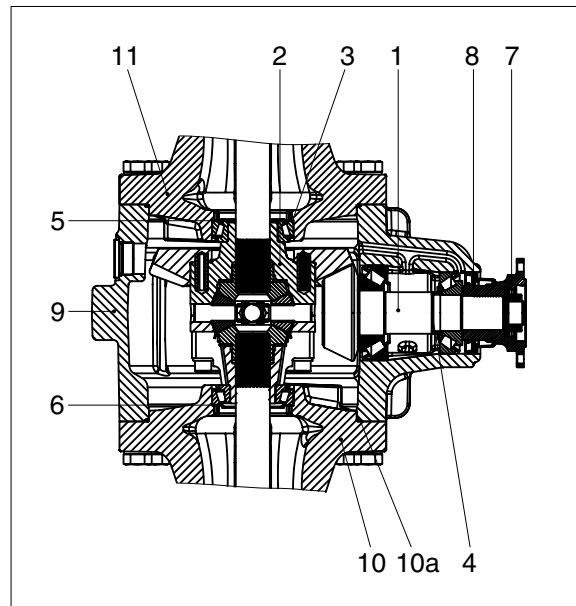

17W7A8RA098

Just for New part assembly or if disassembled :

Install O-ring (10a) on axle housing (10) and mount axle drive housing (9) - observe installation position.

Tightening torque .....  $M_A = 390\text{Nm}$   
(M18 / 10.9)

(2) Determine shim for pinion positioning to obtain an optimum contact pattern of crown wheel / pinion.

Read dimension I (Position - see arrow) from axle drive housing.

Dimension I e.g ..... 149.09mm

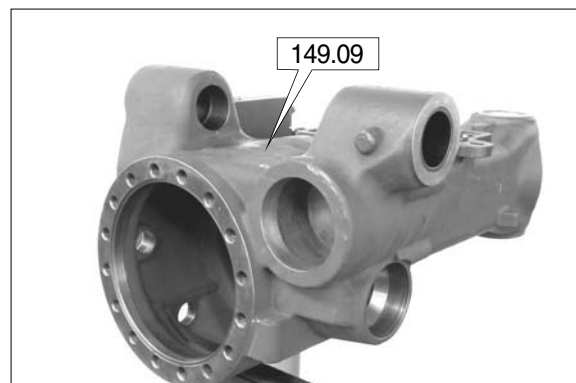

17W7A8FA066

(3) Read pinion dimension (basic distance) X from pinion (see arrow) or measure it in case of a + or - deviation of the pinion dimension caused by the production (value concerned is marked by hand on the pinion, e.g.+ 0.1).

Pinion dimen. X (without + or - deviation) =  
116.0mm

Pinion dimen. X with an indicated<sup>+0.1</sup> deviation = 116.1mm

Pinion dimen. X with an indicated<sub>.0.1</sub> deviation = 115.9mm

Dimension II (Pinion basic distance) e.g  
..... 116.00mm



17W7A8FA067

- (4) Measure dimension III bearing width, observing that the rollers are located without any play (rotate bearing inner ring in both directions several times - roller setting).

Since the installed roller bearing is subject to a pre-load in installation position, consider an experience deduction of 0.1mm.

Dimension III = e.g. 32.00mm - 0.1mm  
→ 31.90mm

(S) Digital depth gauge 5870 200 072

(S) Gauge blocks 5870 200 066



17W7A8FA068

- (5) CALCULATION EXAMPLE :

Dimension I ..... 149.09mm

Dimension II + III (116.00 + 31.90)

..... - 148.10mm

Result ..... = 1.01mm

Shim required ..... S 1.00mm

Insert the determined shim (e.g. S = 1.00mm) into the inner bearing hole / pinion bearing.

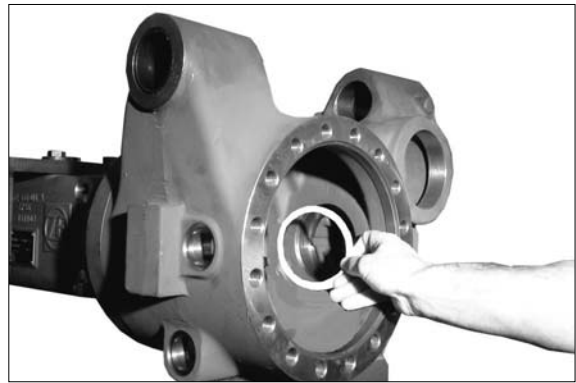

17W7A8FA069

- (6) Super-cool bearing outer ring (see arrow) and bring it into contact position in the inner bearing hole / pinion bearing by means of the fixture.

(S) Assembly fixture 5870 345 049

(S) Assembly ring 5870 345 056

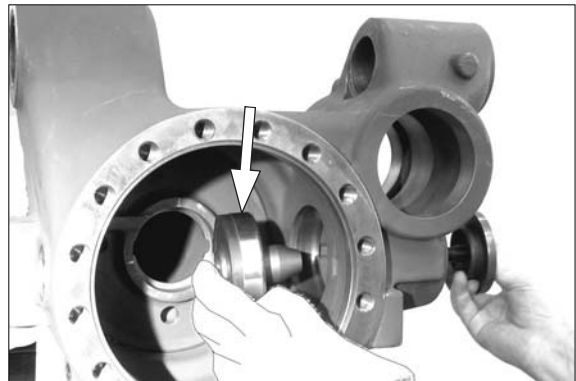

17W7A8FA070

- (7) Install outside bearing outer ring / pinion bearing.

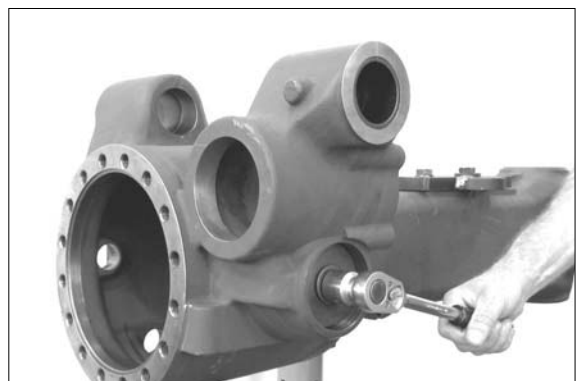

17W7A8FA071

- (8) Mount heated bearing inner ring until contact is obtained and readjust after cooling-down.



17W7A8FA072

- (9) **Adjust rolling moment of drive pinion bearing 1.0~2.0Nm (without seal ring) :**  
Mount spacer ring (s = optional).

- ※ We would recommend to re-install the spacer ring found during disassembly. If, however, the required rolling moment of 1.0~2.0Nm (without seal ring) is not achieved - see bearing rolling moment test - correct the bearing rolling moment by means of a corresponding spacer ring.



17W7A8FA073

- (10) Insert the preassembled drive pinion, mount the heated bearing inner ring until contact is obtained.



17W7A8FA074

- (11) Mount flange, fix with washer and hex nut.

- ※ During tightening, rotate pinion in both directions several times (roller setting).

Tightening torque (M27 × 1.5) .....  
.....  $M_A = 600\text{Nm}$

(S) Clamping fork                      5870 240 025

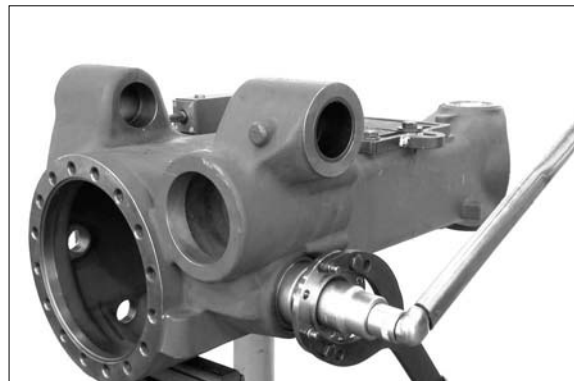

17W7A8FA075

(12) Check rolling moment of pinion bearing.

Bearing rolling moment (without seal ring)

1.0 ~ 2.0 Nm

Try to achieve upper value.

※ If the rolling moment differs from the required value, correct it with a suitable spacer ring (see figure FA073).

(S) Torque wrench 5870 203 030

(S) Reduction 1/4 to 1/2 5870 656 056

(S) Reduction 1/2 to 3/4 5870 656 057

※ Reassemble seal ring . as shown page 8-200~201 (after completed differential assembly and positive contact pattern check).

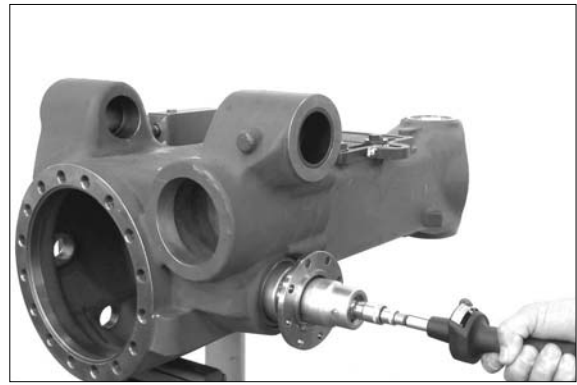

17W7A8FA076

## 2) DIFFERENTIAL

(1) Mount slotted pins (arrows) into differential carrier half, considering the assembly specification, see sketch RA089.

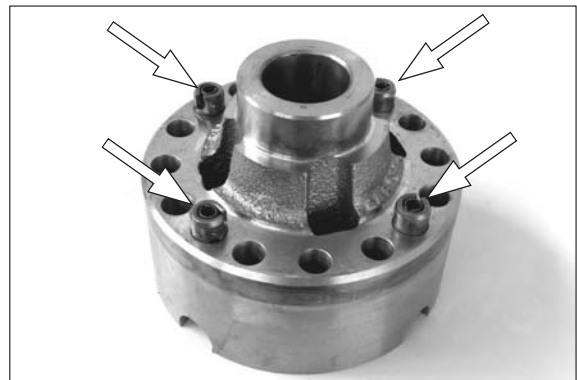

17W7A8FA077

(2) Assembly specification :

Bring slotted pin(s) in a position where slot shows into the direction of force (arrow).

In case of double slotted pins - bring the slots in a 180° offset position to each other.

1 = Differential carrier

2 = Slotted pin

3 = Slotted pin (Just for double slotted pin version)

X = Direction of force

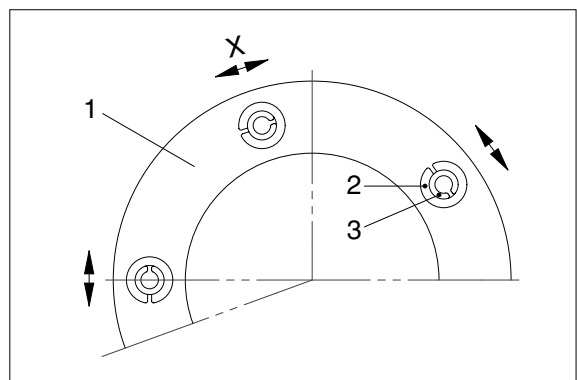

17W7A8RA089

- (3) Press differential carrier until contact is obtained.

Assembly aid -

Insert two adjusting screws into crown wheel.

(S) Adjusting screw            5870 204 027  
(M12 × 1.5)



17W7A8FA079

- (4) Insert thrust washer and axle bevel gear.

※ Put driving lugs of thrust washer into driving holes / differential carrier - do not locate in oil supply recesses.



17W7A8FA080

- (5) Install differential bevel gears and thrust washes on differential spider and insert in differential carrier half I.

※ Ensure radial installation position of thrust washes.  
Lug is looking vertically upward (see arrows).



17W7A8FA081

- (6) Insert second axle bevel gear.



17W7A8FA082

(7) Stick thrust washer with grease (assembly aid) into differential carrier half II. Locate differential carrier half II on differential carrier half I.

※ Put driving lugs of thrust washer into driving holes / differential carrier - do not locate in oil supply recesses.

(8) Fasten differential carrier halves with cylinder. Screws and washers (pos. X).

※ Ensure radial installation position - designation at the same time corresponds to radial position marking.

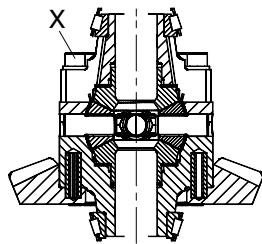

Insert hex screws with locking agent (Loctite - No. 262).

Tightening torque (M12 × 1.5 / 12.9) .....  
 .....  $M_A = 145\text{Nm}$

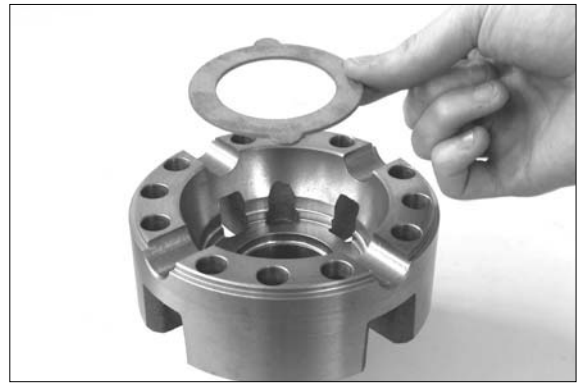

17W7A8FA083



17W7A8FA084

(9) Install both bearing inner rings (arrows).

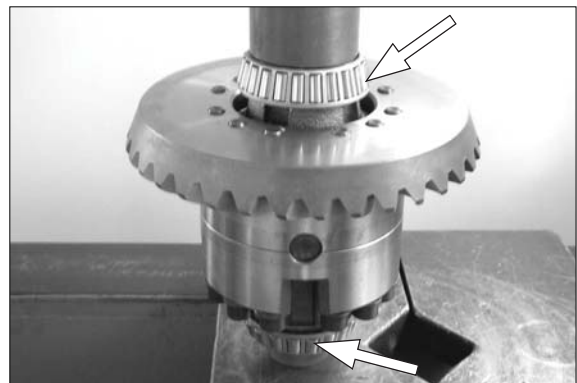

17W7A8FA085

(10) Wet some tooth flanks of the crown wheel with marking ink (for contact pattern check - See figure FA096, page 8-198).



17W7A8FA086

**(11) Adjust backlash of bevel gear set and bearing rolling moment of differential bearing :**

Backlash (crown wheel / drive pinion)  
= 0.12 ~ 0.24mm

Differential bearing preload  
= 0.10 ~ 0.15mm  
(corresponds to a bearing rolling moment  
of 1 ~ 4Nm)

**(12) Bring axle drive housing / axle housing into upright position.**

Insert shim (backlash) into hole of axle housing / part I and install bearing outer ring until contact is obtained.

We would recommend to install the shim (experience value = approx. 1.25mm) found during disassembly - also refer to disassembly instructions page 8-186, FA050.

※ However, the required backlash is decisive for the shim(s) to be used.

(S) Driver 5870 058 061

(S) Grip 5870 260 002



17W7A8FA087

**(13) Insert pre-assembled differential.**



17W7A8FA088

**(14) Place bearing outer ring.**

※ Locate the bearing outer ring on the bearing inner ring, until all rollers are located without any play.

※ For this purpose rotate differential and bearing outer ring in both directions several times - roller setting.

A correct positioning of bearing outer ring and differential is imperative for the following measuring operation.



17W7A8FA089

(15) Determine dimension I, from mounting face of axle drive housing to bearing contact.

Dimension I e. g. .... 18.10mm

(S) Digital depth gauge 5870 200 072

(S) Gauge blocks 5870 200 066

(S) Measuring bar 5870 200 126

※ Make measurement on several points and calculate mean value.

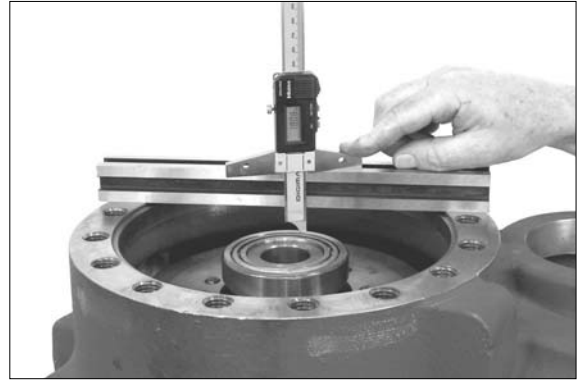

17W7A8FA090

(16) Determine dimension II, from mounting face of axle housing to contact face / bearing outer ring.

Dimension II e. g. .... 17.20mm

CALCULATION EXAMPLE :

Dimension "I" e. g. .... 18.10mm

Dimension "II" e. g. .... - 17.20mm

Difference ..... = 0.90mm

Requ. bearing preload ..... + 0.13mm  
(0.10 ~ 0.15mm)

Result ..... = 1.03mm

**Required shim S = 1.05mm**

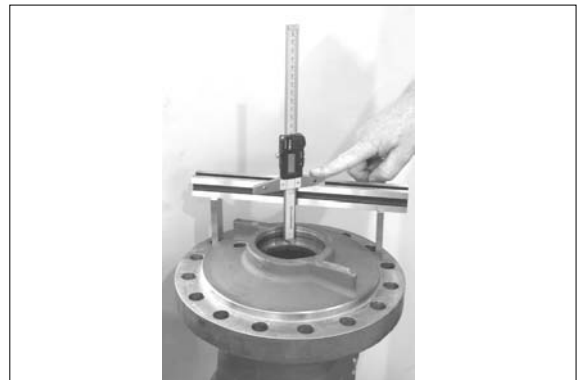

17W7A8FA091

(17) Insert determined shim (s) e. g. **S** = 1.05mm into bearing hole of axle housing and install bearing outer ring so that contact is obtained.

※ Install (stick) bearing outer ring into hole with grease - assembly aid.

(S) Driver 5870 058 061

(S) Grip 5870 260 002



17W7A8FA092

- (18) Locate preassembled axle housing (without O-ring) (observe radial installation position) and temporarily fix with hex. screws.



17W7A8FA093

**(19) Backlash and contact pattern check :**

Place dial indicator at right angles to a tooth flank of the crown wheel (within the outer diameter area) through oil drain hole and check backlash.

Backlash = 0.12 ~ 0.24mm

- ※ In case of a deviation from the specified backlash, correct it with a suitable shim (see figure FA087).
- ※ A correction of shim / backlash also requires a correction of shim / bearing rolling moment to the opposite direction (see figure FA092).

(S) Magnetic stand            5870 200 055  
(S) Dial indicator            5870 200 057

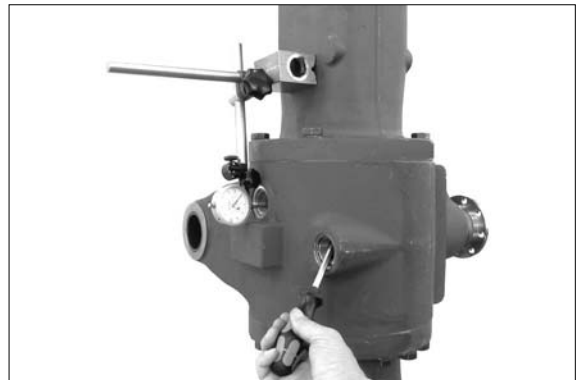

17W7A8FA094

- (20) Rotate drive pinion in both directions several times over crown wheel / differential (contact pattern impression - in this connection see figure FA096).



17W7A8FA095

- (21) Remove differential.

Compare contact pattern (see arrow) with contact pattern examples.

- ※ If the contact pattern differs considerably, an error was made when measuring the shim (see figure FA087, page 8-196), which needs to be corrected by all means.



17W7A8FA096

(22) Oil O-ring and mount on collar (arrow) of axle housing half.



17W7A8FA097

(23) Reinstall differential.



17W7A8FA098

(24) Install pre-assembled axle housing half (observe radial installation position), fix with hex. screws and washers.

Tightening torque (M18/10.9) .....  
.....  $M_A = 390\text{Nm}$



17W7A8FA099

(25) Bring axle into horizontal position and secure with a support (arrow).



17W7A8FA100

(26) Disassemble flange.

(S) Clamping fork 5870 240 025

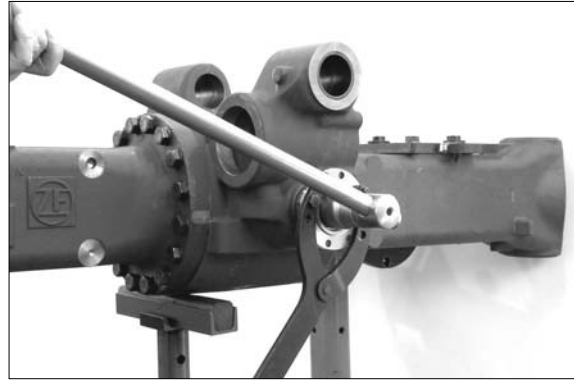

17W7A8FA101

### 3) INPUT FLANGE

(1) Comment on sketch RA125~figure FA105 :

- |                  |                          |
|------------------|--------------------------|
| 1 = Drive pinion | 6 = Seal ring            |
| 2 = Hex. nut     | 7 = Bevel roller bearing |
| 3 = Washer       | 8 = Spacer ring          |
| 4 = Input flange | 9 = Input housing        |
| 5 = Screen       |                          |

X = Installation dimension .....  $13.0^{+0.2}\text{mm}$

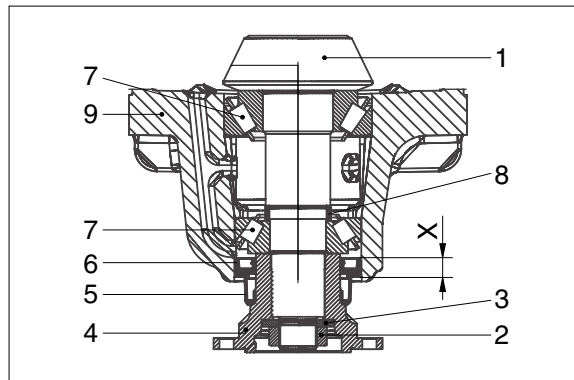

17W7A8RA125

(2) Place seal ring(6), considering the required installation position (dimension X) - see sketch RA125.

- Contact face (outer diameter) of seal ring :
- wet it with spirit (assembly aid) if rubber coated
  - apply sealing agent (Loctite no. 574) if made of metal

Apply grease on seal and dust lip of the seal ring.

※ Ensure plane installation position of seal ring - use suitable driver.

(S) Driver 5870 048 269

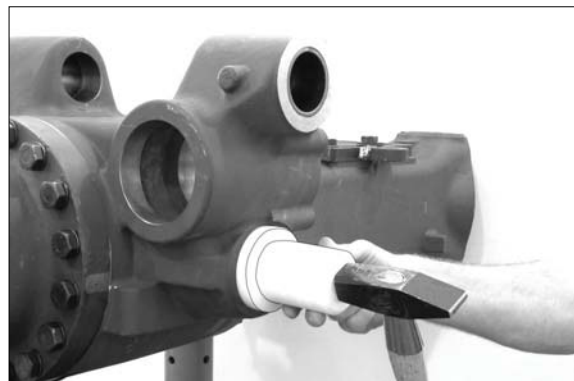

17W7A8FA103

(3) Press screen/thrust plate (5) on the input flange until contact is obtained - also see sketch RA125.

※ Screen/thrust plate must not be deformed when mounted - use suitable driver.



17W7A8FA104

(4) Install pre-assembled input flange (4+5) and washer (3), fix with hex. nut (2).

※ Secure hex. nut with locking agent (Loctite-no. 262).

Tightening torque (M27 × 1.5) .....

.....  $M_A = 600\text{Nm}$

(S) Clamping fork                      5870 240 025

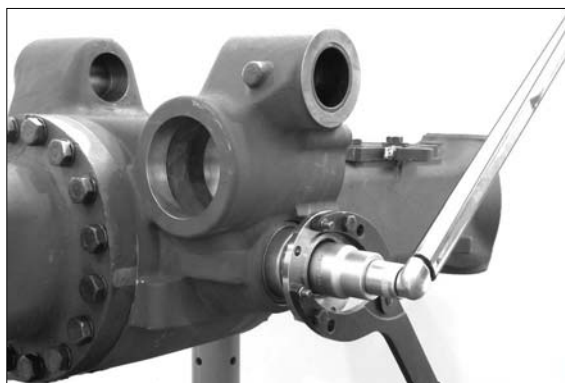

17W7A8FA105

#### 4) Output

(1) Comment on sketch RA023 :

- 1 = Axle housing
- 2 = Knuckle housing
- 3 = Hub
- 4 = Multi-disc brake
- 5 = Planetary carrier

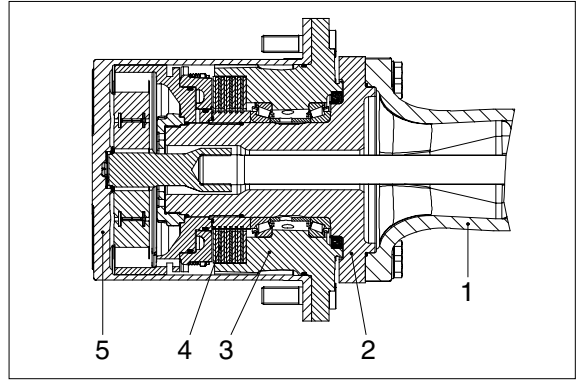

(2) Mount just for cpl. output.

Locate the cpl. output on the axle - by installing the u-joint shaft in the differential tothing.

※ Pay attention to seal ring in the axle housing - risk of damage.

Other required work steps (bearing pin and tie rod assembly) can be taken in extracts from the complete assembly (**Knuckle housing**, page 8-204~207 and **steering**, page 8-218).

(S) Lifting bracket 5870 281 043

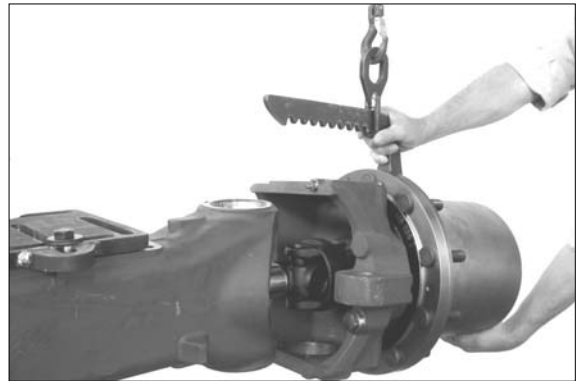

#### (3) Pre-assemble axle housing

Legend on sketch FA108 ~ Figure FA111 :

- 1 = Axle housing
- 2 = Bushing (observe installation position)
- 3 = Seal ring (observe installation position)
- 4 = Bearing outer rings (pivot bearing)
- X = Oil chamber side

Bushing - lubrication groove outlet installed in 6 o'clock position (referred to the axle mounted in the vehicle).

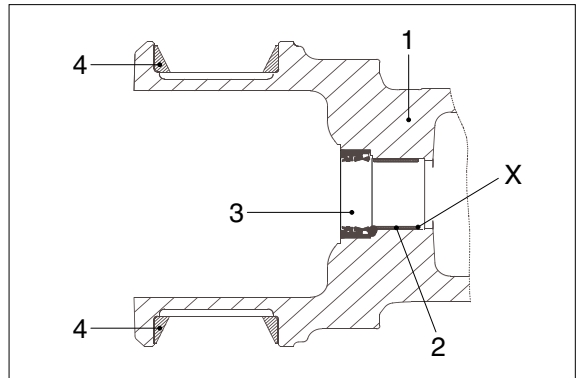

(4) Flush - mount bushing in the axle housing hole, considering the installation position (see detailed sketch).

Detailed sketch - 90° offset :

- 1 = Axle housing

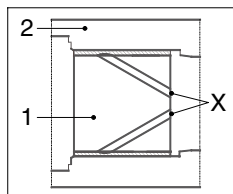

- 2 = Bushing
  - X = Oil chamber side
- Observe installation position of bushing lubrication groove outlet in 6 o'clock position (referred to axle mounted in vehicle).

(S) Driver 5070 055 090



(5) Flush-mount seal ring (item 3 - see sketch FA108) into axle housing hole, with seal lip showing to oil chamber.

- ※ Contact face (outer diameter) of seal ring :
    - Wet it with spirit (assembly aid) if rubber-coated.
    - Apply sealing agent(Loctite no. 574) if made of metal
- Apply grease on seal and dust lip of the seal ring.

※ Ensure plane installation position of seal ring - use suitable driver.

(S) Driver 5870 055 090



17W7A8FA110

(6) Mount both bearing outer rings (Item 4 - see sketch FA108) into pivot bearing holes of the axle housing.

(S) Driver 5870 058 022

(S) Grip 5870 260 002



17W7A8FA111

(7) Carefully install u-joint shaft  
(Risk of damage - seal ring).



17W7A8FA112

**(8) Knuckle housing**

Just for assembly of a new knuckle housing : (Figure FA113)

Shut machining openings (3x - see arrows) of oil supply holes with plugs.

(S)Lever riveting tongs 5870 320 016

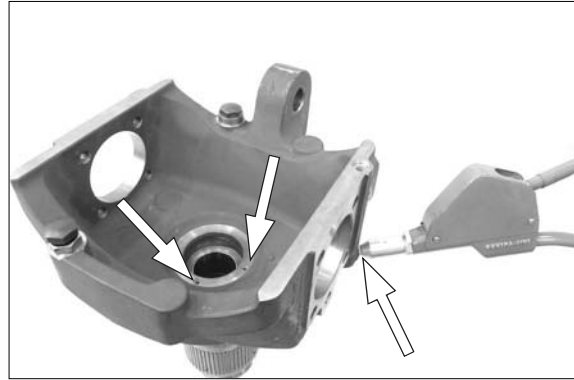

17W7A8FA113

**(9) Legend to sketch FA114 ~ Figure FA116 :**

- 1 = Knuckle housing
- 2 = Bushing (observe installation position)
- 3 = Seal ring (observe installation position)
- E = Installation dimension (seal ring) .....
- ..... 4.00<sup>+0,3</sup>mm

X = Oil chamber side

Installation position of bushing

Lubrication groove outlet in 6 o'clock position (referred to knuckle housing / axle mounted in vehicle).

Flush-mount bushing into knuckle housing hole, considering the Installation position (see sketch FA114 and detailed sketch).

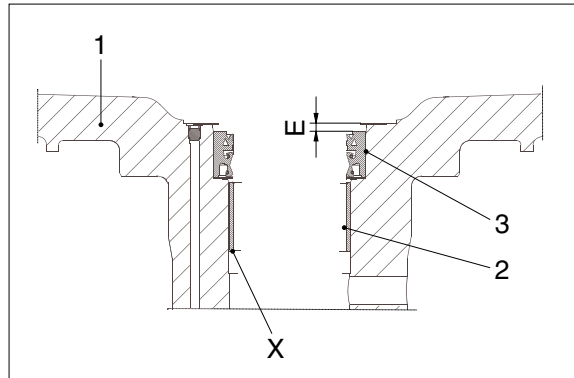

17W7A8FA114

**(10) Detailed sketch:**

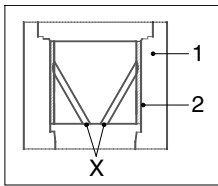

- 1 = Knuckle housing
- 2 = Bushing
- X = Oil chamber side
- Observe installation position of bushing

Lubrication groove outlet in 6 o'clock position (referred to knuckle housing / axle mounted in vehicle).

(S) Driver 5870 055 090



17W7A8FA115

**(11) Mount seal ring(item 3 - see sketch FA114)**

into knuckle housing hole - considering installation dimension **E** and installation position (seal lip showing to oil chamber).

- ※ Contact face (outer diameter) of seal ring :
  - Wet it with spirit (assembly aid) if rubber-coated
  - Apply sealing agent (Loctite no. 574) if made of metal

Apply grease on seal and dust lip of the seal ring.

- ※ Ensure plane installation position of seal ring - use suitable driver.

(S) Driver 5870 055 090



17W7A8FA116

(12) Locate pre-assembled knuckle housing on axle housing, and carefully mount u-joint shaft (Seal ring - risk of damage).

(S)Lifting chain                    5870 281 047  
 2 Eyebolt M16                    0636 804 001



17W7A8FA117

(13) Legend to sketch FA118 ~ Figure FA121 :

- 1 = Bearing pin
- 2 = Sealing cap
- 3 = O-ring
- 4 = Bevel roller bearing
- 5 = Shim (just on lower bearing pin)
- 6 = Lubrication nipple
- 7 = Knuckle housing
- 8 = Axle housing
- X = Area / anti - corrosive agent

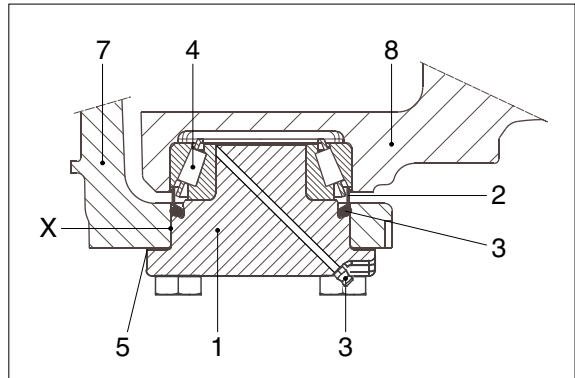

17W7A8FA118

(14) Mount sealing cap

- Observe installation position (see sketch FA118).

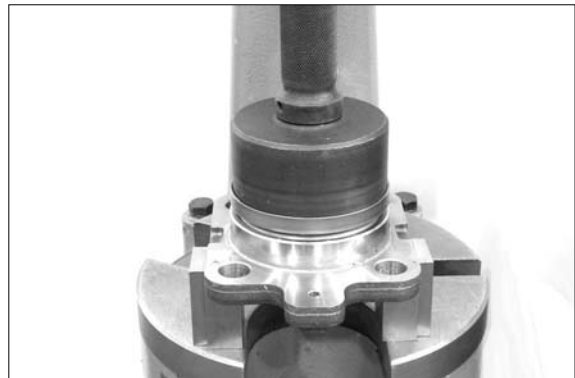

17W7A8FA119

(15) Install O-ring (arrow - 1) and apply anti - corrosive agent, bearing pin collar (arrow - 2)

Mount bearing inner ring

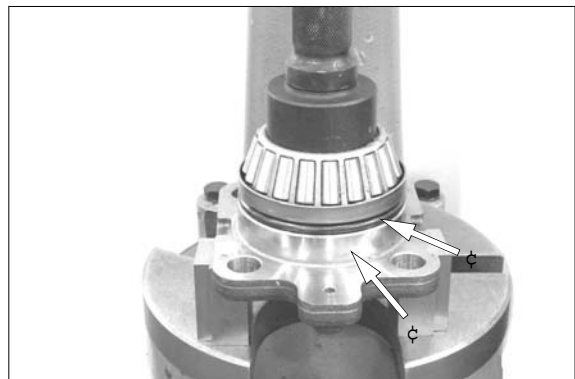

17W7A8FA120

- (16) Just on lower bearing pin :  
Install shim for pivot bearing moment setting  
e.g.  $S = 0.80$  mm (experience value) on lower bearing pin.

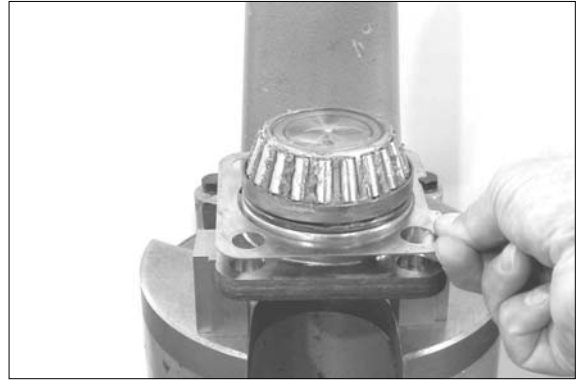

17W7A8FA121

- (17) Install pre-assembled lower bearing pin and fix with hex. screws.

- ※ Observe installation position - mount bearing pin with lubrication nipple showing to axle center.

(S) Lifting chain                      5870 281 047  
    2 Eyebolt M16                      0636 804 001

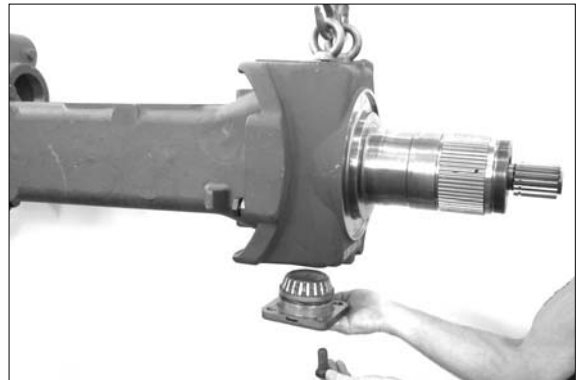

17W7A8FA122

- (18) Install O-ring.



17W7A8FA123

- (19) Install pre-assembled upper bearing pin (figure FA119 and FA120).

- ※ Observe installation position - oil supply holes for multi - disc brake.



17W7A8FA124

(20) Fix both bearing pins definitively.

Tightening torque (M16 / 10.9) .....  
 .....  $M_A = 280\text{Nm}$

(21) Mount lubrication nipple (arrow - 1) in both bearing pins and provide pivot bearing with grease.

Tightening torque (M6 × 1) . . . .  $M_A = 6\text{Nm}$

Just on upper bearing pin :

Mount screw neck (arrow - 2) with O-ring.

Tightening torque (M14 × 1.5) .....  
 .....  $M_A = 35\text{Nm}$

Mount breather valve (arrow-3) and apply dust cap.

Tightening torque (M14 × 1.5) .....  
 .....  $M_A = 20\text{Nm}$

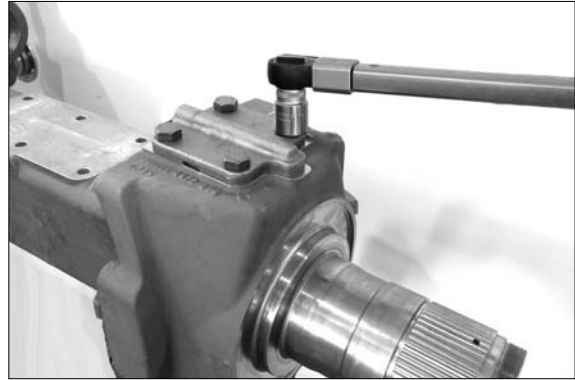

17W7A8FA125

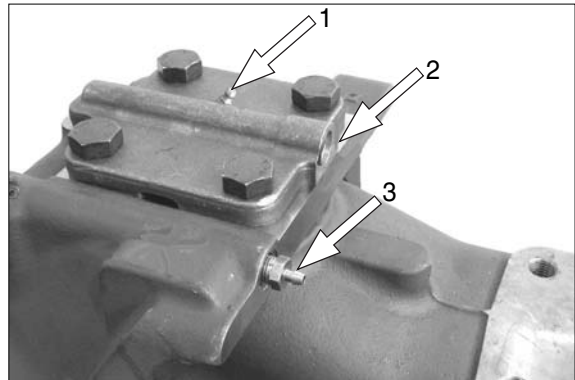

17W7A8FA126

(22) Check rolling moment of pivot bearing.

For this purpose locate torque wrench on a hex. screw, align at bearing pin center and determine bearing rolling moment considering the following formula.

Bearing rolling moment ..... 50 ~ 60Nm

※ Try to achieve the upper value of bearing roller moment.

In case of a deviation from the specified bearing rolling moment, correct it with a suitable shim. (see figure FA121).

(S) Torque wrench                      5870 203 034



17W7A8FA127

(23) **TE** = Effective torque on the central swivel point (bearing pin center)

**L** = Distance - from torque wrench point of attach (hex. screw center) to grip center (torque wrench)  
 e.g. L = 300mm (0.3m)

**A** = Distance - from torque wrench socket (hex. screw center) to bearing pin center (central swivel point) e.g. A=60mm(0.06m)

**TS** = Value of the torque to be read from the scale

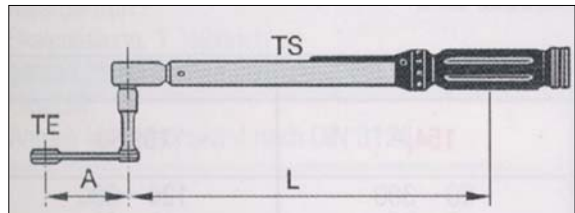

17W7A8FA128

$$TE = \frac{TS \times (L+A)}{L}$$
 As a result the scale of the torque wrench must indicate a value of 46 ~ 50Nm, which corresponds to an effective bearing rolling moment of 50 ~ 60Nm

$$TS = \frac{TE \times L}{L + A}$$
 in the swivel bearing.

**(24) Hub**

Install heated bearing inner ring until contact is obtained.

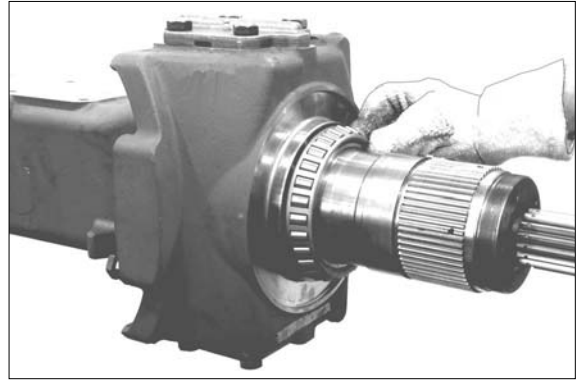

17W7A8FA129

**(25) Install spacer bushing.**

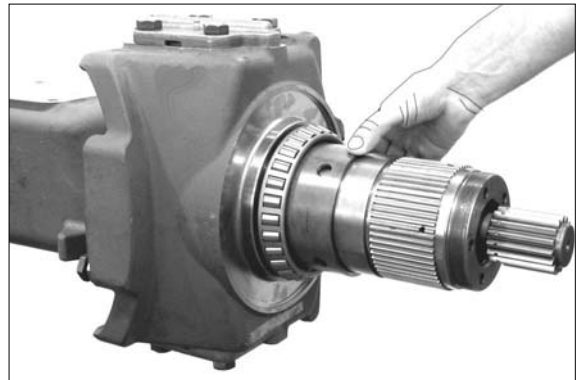

17W7A8FA130

**(26) Mount wheel bolts (1).**

Install both bearing outer rings (2) of hub bearing until contact is obtained.

Oil O-ring (3) and locate in annular groove of hub.

Mount shaft seal, considering installation position (marking OUT - SIDE looking upward / outward) and installation dimension **X** - see detailed sketch.

1 = Hub

2 = Shaft seal

X = Installation dimension

X = 0.0 ~ 0.3mm

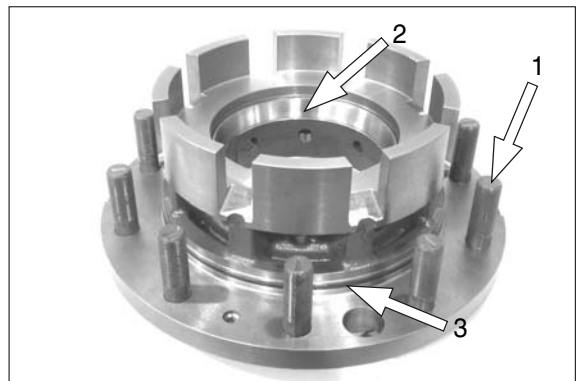
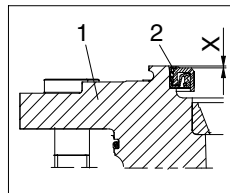

17W7A8FA131

**(27) Apply sealing agent (Loctite-No. 574) to contact face shaft seal / hub.**

※ Wet contact face of shaft seal / hub carrier with spirit at the very beginning of the assembly - assembly aid.

(S) Driver

5870 051 035



17W7A8FA132

(28) Install preassembled hub until contact is obtained and fix with heated outer bearing inner ring

(S) Lifting bracket 5870 281 043

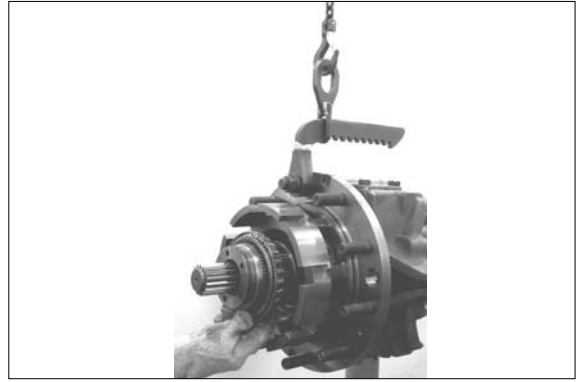

17W7A8FA133

(29) Oil O-rings and locate in annular groove (arrow) of knuckle housing. Then install disc carrier.



17W7A8FA134

(30) Bring hub bearing into contact position (figure-FA135~FA137) :  
Install ring gear (without sealing elements).

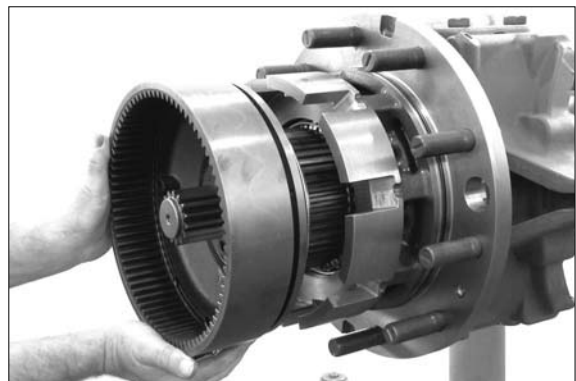

17W7A8FA135

(31) Bring hub bearing into contact position - for this purpose tighten slotted nut with a tightening torque of max. 1400Nm.

- ※ Apply lubricant to thread - knuckle housing / slotted nut.
- ※ While tightening the slotted nut rotate hub in both directions several times - roller setting.

(S) Socket spanner 5870 656 097



17W7A8FA136

(32) Loosen slotted nut again and remove ring gear.



17W7A8FA137

### (33) Multi-disc brake

Install disc pack alternately starting with an outer disc.

- ※ Pay attention to installation position of inner discs - see figure FA139.
- ※ Take the actually required disc fitting from the corresponding spare parts list.

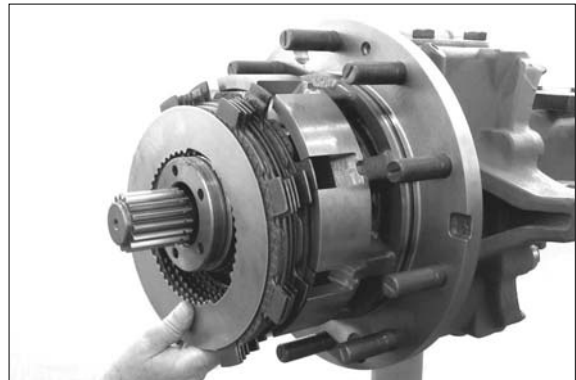

17W7A8FA138

(34) Installation position of inner discs :

- ※ Bring inner clutch discs in a position where one of the tooth recesses (arrow) is in 6 o'clock position - with axle being installed in the vehicle.
- ※ Inner clutch discs  $s = 2.5\text{mm}$  (Standard)  
Install inner clutch discs with  $s =$  alternatively (2.0 - 2.5 - 3.0mm)  
- Required for disc clearance adjustment -  
on the outside of the disc pack.

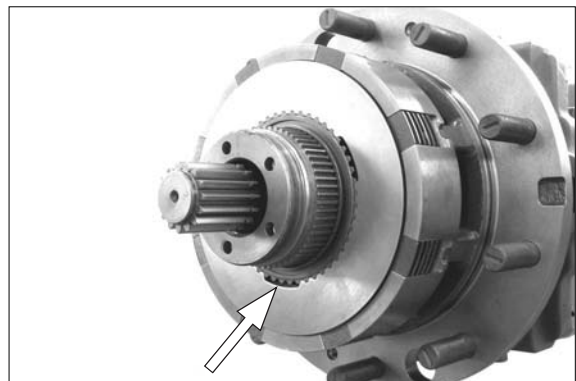

17W7A8FA139

(35) Oil O-ring and locate in annular groove of disc carrier.

- ※ Stick O-ring by means of grease - assembly aid.

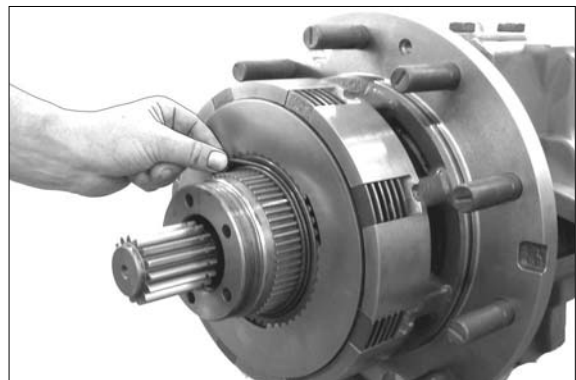

17W7A8FA140

(36) Oil sealing elements and locate in annular grooves (arrows) of the ring gear - as shown in the detailed sketch.

※ Pay attention to installation position and arrangement of sealing elements.

- 1 = Ring gear
- 2 = Support ring
- 3 = U-ring
- 4 = U-ring
- 5 = Support ring

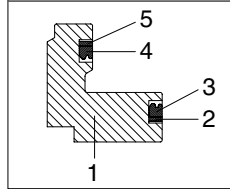

17W7A8FA141

(37) Just for assembly of new parts or if disassembled:

Mount cylindrical pins into piston, considering installation dimension  
**X** ..... 16.00mm



17W7A8FA142

(38) Install piston on preassembled ring gear.



17W7A8FA143

(39) Legend to detail A:

- 1 = Hex. screw
- 2 = Spring sleeve
- 3 = Compress. springs (outer)
- 4 = Compr. springs (inner)

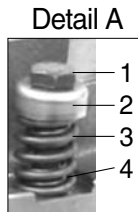

Fix piston with spring sleeve (2), compression springs (3 and 4) and new hex screws (1).

※ Use hex. screws just once for assembly.

Tightening torque (M6 / 8.8) .....  
 .....  $M_A = 11Nm$

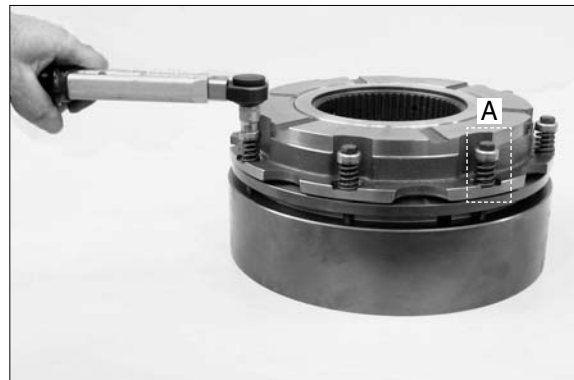

17W7A8FA144

(40) Mount preassembled ring gear considering the installation position (markings O in 12 o'clock position - see arrows, detail B).

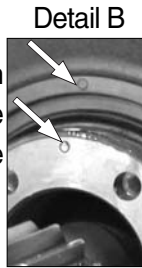

- ※ Ensure exact tothing position of oil supply holes - knuckle housing / ring gear (pressure oil supply to brake piston).

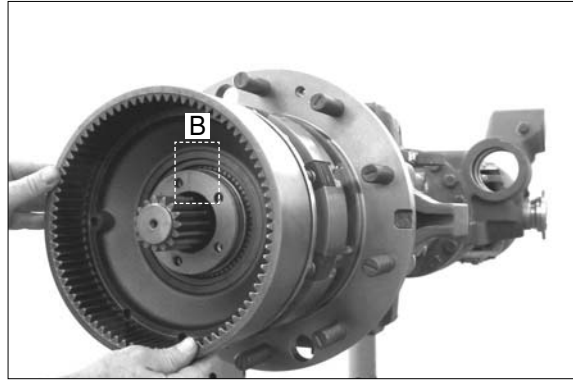

17W7A8FA145

(41) Oil O-ring and insert it in recess (arrow).

- ※ Apply lubricant on thread - knuckle housing / slotted nut.



17W7A8FA146

(42) Fix ring gear with slotted nut.

- ※ First tighten slotted nut with 1400Nm, then retighten slotted nut until a fixing hole overlaps a threaded hole in the knuckle housing - in this connection also refer to fig. FA 153.
- ※ While tightening the slotted nut rotate hub in both directions several times - roller setting.

Tightening torque .....  $M_A = 1400^{+200}$ Nm  
(M 110 × 1.5)

(S) Socket spanner                    5870 656 097



17W7A8FA147

**(43) Make leakage test of multi - disc brake :**  
Mount breather valve (arrow) and connect HP pump (to connection hole/bearing pin).

(S) HP pump                                5870 287 007

(S) Threaded coupling                5870 950 102  
(M14 × 1.5)

(S) Breather bottle                    5870 286 072

- ※ Breathe brake completely before starting the test.

Test media :

Motor oils SAE - 10 W correspond to,  
SAE85W-90 with LS-ADDITIVE

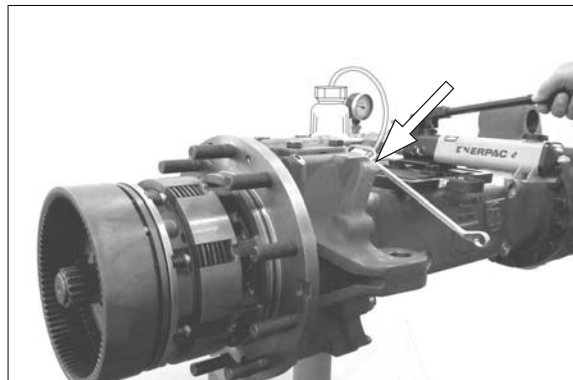

17W7A8FA148

(44) High - pressure test :

Build up test pressure  $p = 100$  bar and close locking valve of HP - pump.

A pressure drop by max. 3 bar is permissible during a 5 - minute test duration.

Low pressure test :

Reduce test pressure to  $P = 5$  bar and close locking valve.

No pressure drop is allowed during a 5-minute testing duration.

(45) Adjust and check disc clearance/piston stroke :

Disc clearance / piston stroke .....

.....  $X = 1.2 \sim 1.8$  mm

Legend to fig. FA149 and sketches RA048 + RA049 :

1 = Ring gear                      2 = Measuring hole

3 = Piston

$X$  = Disc clearance / piston stroke

(S) Straightedge                      5870 200 022

(S) Digital depth gauge              5870 200 114

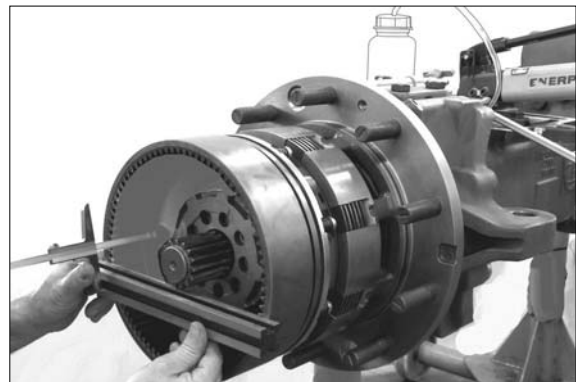

17W7A8FA149

(46) Breathe brake completely before starting the test.

- ※ Build up braking pressure (100 bar) and find dimension **A**, from face / ring gear (1) through measuring hole (2) - see figure FA149 and sketch RA048 - to face / piston (3).

Dimension **A** e.g. .... = 83.50mm

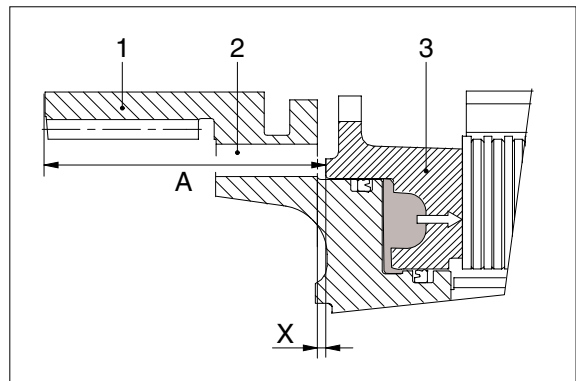

17W7A8RA048

- (47) Release pressure from brake - i.e. no pressure applied on brake, piston is in contact with ring gear (reset piston through compression springs) - and find dimension **B** from face / ring gear (1) through measuring hole (2) - see figure FA149 and sketch RA049 - to face / piston(3).

Dimension **B** e.g. .... = 82.10mm

CALCULATION EXAMPLE:

Dimension **A** e.g. .... 83.50mm

Dimension **B** e.g. .... - 82.10mm

Result → disc clearance ..... = 1.40mm

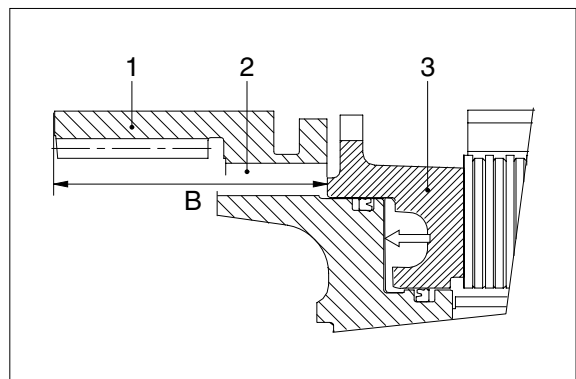

17W7A8RA049

- ※ If the required disc clearance / piston stroke ( $X = 1.2 \sim 1.8$  mm) is not achieved, correct it with corresponding inner clutch disc(s) - see figure FA139.

(48) Dismantle HP pump.

Just for transport protection, install screw plug with O-ring in oil supply hole.

Tightening torque .....  $M_A = 23\text{Nm}$   
(M 14 × 1.5)

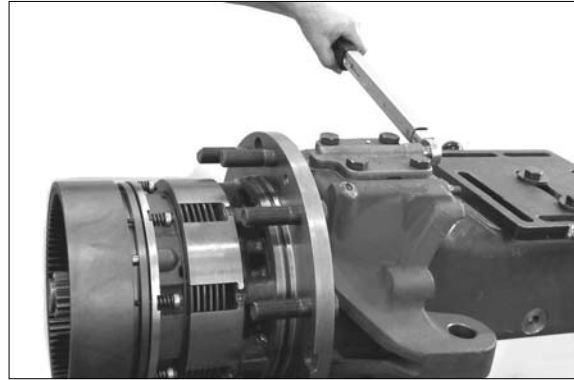

17W7A8FA152

(49) Secure slotted nut with cylinder screw - in this connection refer to comment on figure FA149.

Tightening torque .....  $M_A = 32\text{Nm}$   
(M10 / 8.8)

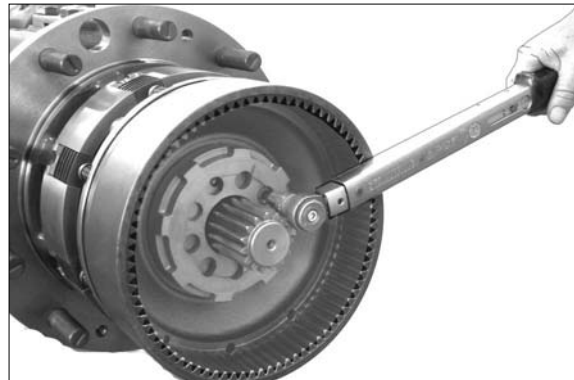

17W7A8FA153

(50) Install thrust washer.

- ※ Observe installation position - ensure that both lugs of the thrust washers are engaged each in a spare fixing hole of the slotted nut.

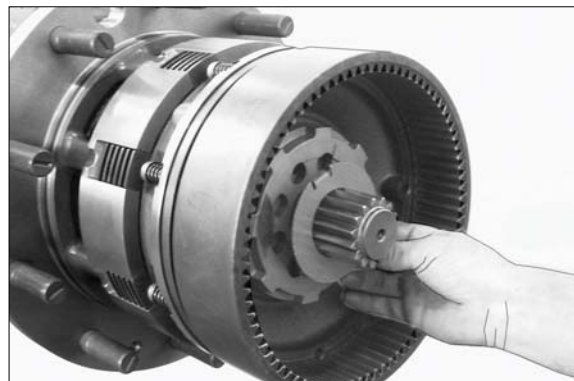

17W7A8FA154

(51) Mount thrust washer (retaining ring fixing)  
- with shoulder showing to retaining ring -  
then snap retaining ring.

(S) Set of external pliers 5870 900 015



17W7A8FA155

**(52) Planetary carrier**

**Adjust axial play of sun gear shaft  
0.3 ~ 1.0mm (figure FA156 ~ FA162)**

Determine dimension I from mounting face of planetary carrier to contact face of thrust washer.

Dimension I, e.g. .... 260.65mm

(S) Straightedge 5870 200 022

(S) Digital depth gauge 5870 200 114

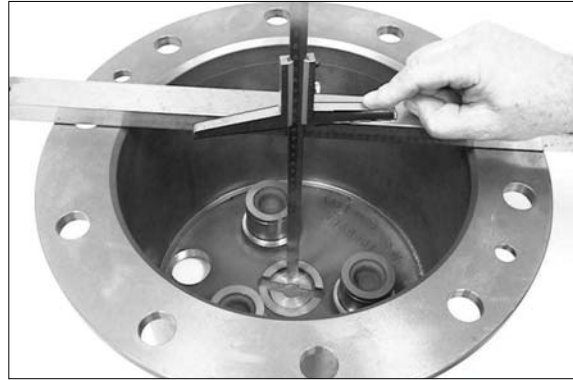

17W7A8FA156

**(53) Determine dimension II, from face (arrow) of sun gear to mounting face of hub.**

Dimension II, e.g. .... 255.70mm

**CALCULATION EXAMPLE :**

Dimension I e.g. .... 260.65mm

Dimension II e.g. .... 255.70mm

Difference ..... = 4.95mm

Required axial play (average) e.g. ....

..... - 0.65mm

Result = require thrust washer(s) e.g. ....

..... S = 4.30mm

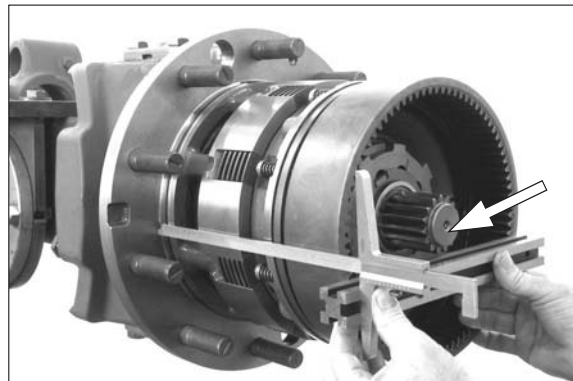

17W7A8FA157

**(54) Insert thrust washer(s) (e.g. s = 4.30mm) into planetary carrier and press into contact position.**

(S) Driver 5870 048 245



17W7A8FA158

**(55) Preassemble planetary gear - depending on version - as shown in the figure beside.**

Legend to figure FA159 :

1 = Planetary gear

2 = Roller bearing

3 = Washer

4 = Circlip

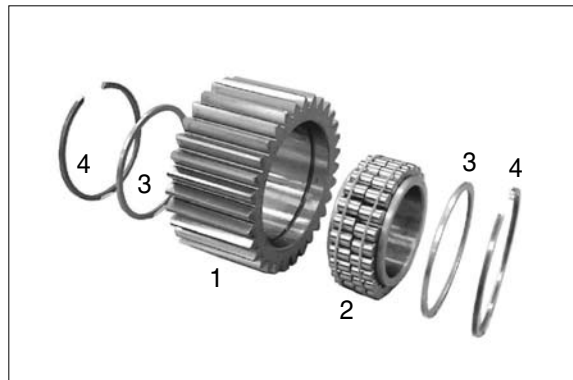

17W7A8FA159

(56) Warm up bearing inner ring and install pre-assembled planetary gear until contact is obtained.

※ Mount planetary gear or bearing inner ring with large radius looking to planetary carrier (downward).

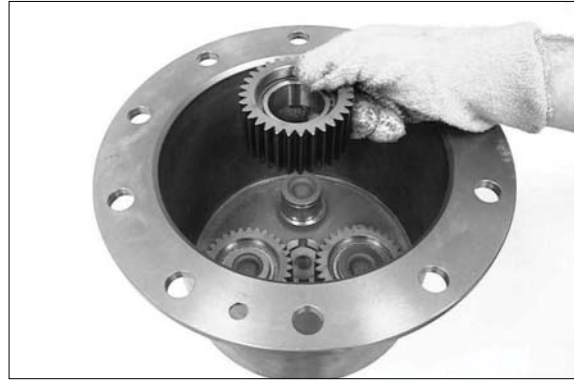

17W7A8FA160

(57) Fix planetary gear by means of retaining ring.

(S) Set of external pliers 5870 900 015



17W7A8FA161

(58) Install preassembled planetary carrier and fix with cylinder screws.

Tightening torque .....  $M_A = 55\text{Nm}$   
(M12 / 8.8)

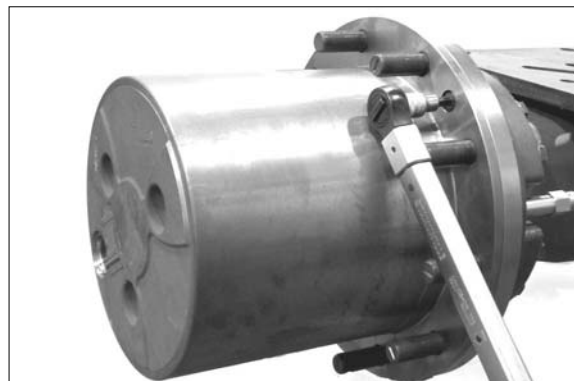

17W7A8FA162

(59) Install screw plug with new O-ring.

Tightening torque .....  $M_A = 50\text{Nm}$   
(M 36 × 1.5)



17W7A8FA163

## 5) PIVOT BEARING

Heat pivot bearing hole by means of hot-air blower and insert super-cooled bushing(s).

- ※ Observe installation position for bushing version with slot, insert bushing - with slot in 12 o'clock position.

(S) Hot air blower 230V      5870 221 500

(S) Hot air blower 115V      5870 211 501



17W7A8FA164

## 6) STEERING

(1) Legend to sketch FA165 ~ Figure FA177 :

- 1 = Steering cylinder  
(cylinder tube with brake head)
- 2 = Brake head (loose part)
- 3 = Piston rod
- 4a = O-ring
- 4b = Form seal ring
- 5 = Guide ring
- 6 = U-ring
- 7 = Rod wiper
- 8 = Dual ring
- 9 = Circlip
- 10 = O-ring
- 11 = Retaining ring
- 12 = Flange
- 13 = Circlip
- 14 = Wrench socket (piston rod)

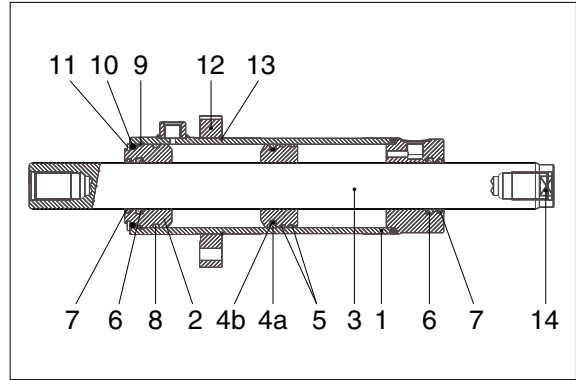

17W7A8FA165

(2) Mount U-ring (6) and wiper (7) in the steering cylinder (1).

※ Observe installation position - in this connection see detailed sketch.

Detailed sketch :

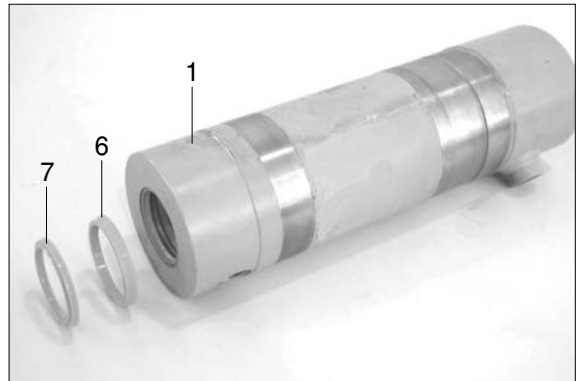
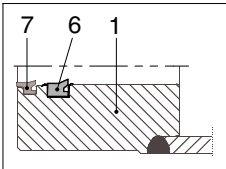

17W7A8FA166

(3) Position inner installer (S1) on piston rod (3), install O-ring (4b) and press with inner installer (S2) into annular groove (arrow) of piston (3).

(S) Inner installer (S1)      5870 651 086

(S) Inner installer (S2)      5870 651 087

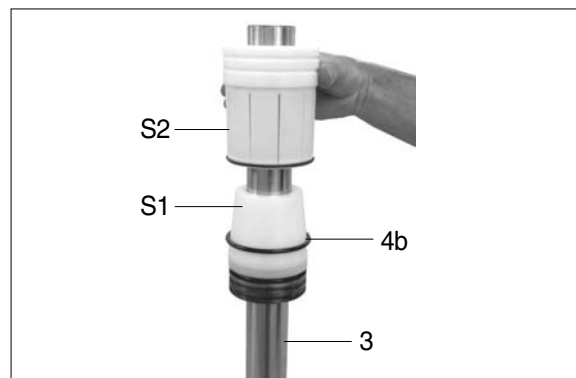

17W7A8FA167

- (4) Install from seal ring (4a) and press with inner installer (S2) into annular groove (arrow) of piston (3).

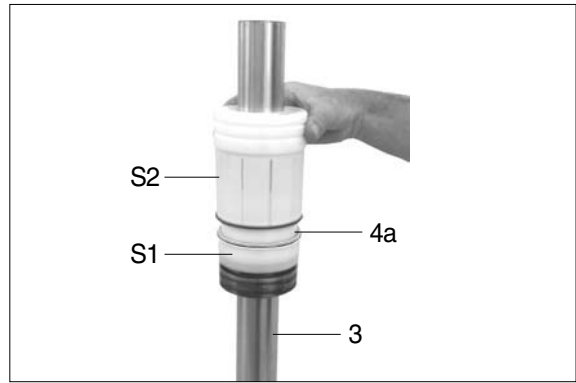

- (5) Calibrate form seal ring (4a) by means of calibration bushing (S3).  
(S) Calibration bushing (S3) 5870 651 090

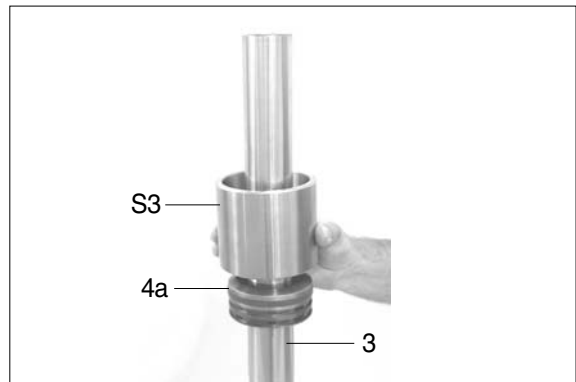

- (6) Place both guide rings (5) into annular grooves of the piston rod.

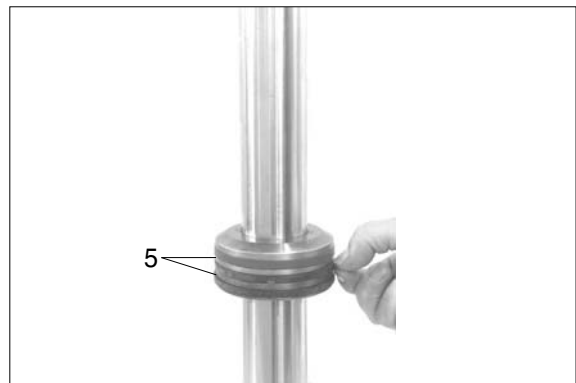

(7) Insert preassembled piston rod in the preassembled steering cylinder.

※ Observe installation position - insert piston rod (3) with wrench point of attach (14 - see sketch FA165) showing in direction of arrow.

※ Slightly oil all sealing elements before installing the piston rod.



17W7A8FA171

(8) Insert U-ring (6), rid wiper (7) and dual ring (8) in brake head (2).

Observe installation position - in this connection refer to detailed sketch.

Detailed sketch :

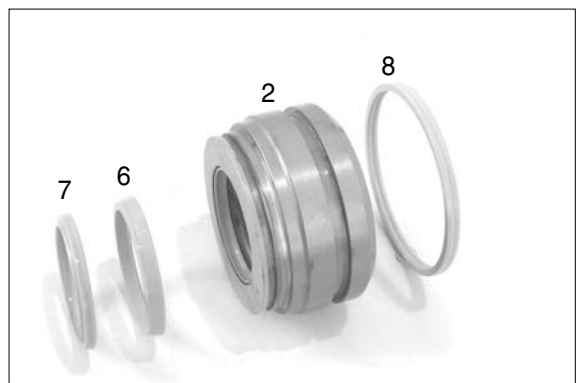
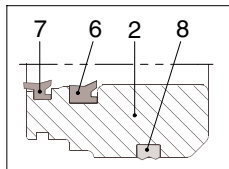

17W7A8FA172

(9) Install preassembled brake head.

※ Slightly oil all sealing elements before inserting the brake head.



17W7A8FA173

(10) Push brake head into the steering cylinder (arrow) so that the circlip (9) can be mounted.



17W7A8FA174

- (11) Bring the inserted brake head (8) into contact position (arrow) on the snapped circlip (9).  
Oil O-ring (10) and insert it into recess.

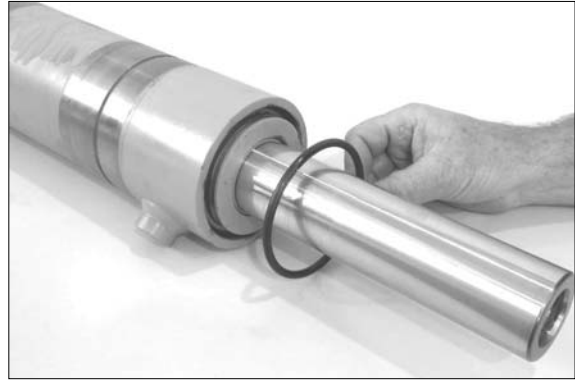

17W7A8FA175

- (12) Fix brake head (8) with retaining ring (11).  
(S) Set of external pliers 5870 900 015



17W7A8FA176

- (13) Install flange (12) and snap circlip (13).  
※ Observe installation position of flange - chamfer (circlip contact - arrow) to show towards circlip.

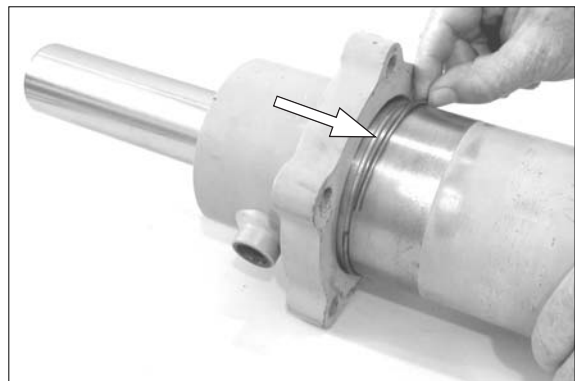

17W7A8FA177

- (14) Provide both contact faces (steering cylinder / axle drive housing) with sealing agent (Loctite - No. 574.)

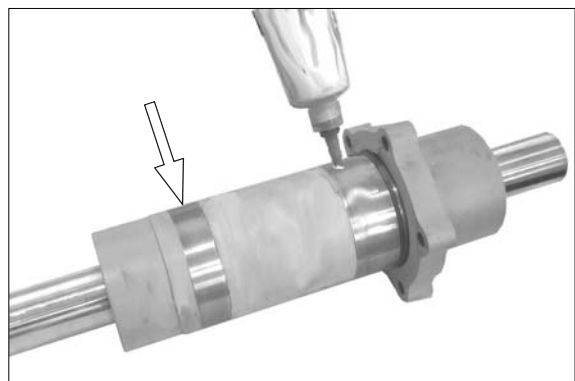

17W7A8FA178

(15) Insert preassembled steering cylinder and fix with hex. screws.

※ Fix hex screws with locking agent (Loctite-No. 243).

Tightening torque (M 12 / 8.8) .....  
 .....  $M_A = 79\text{Nm}$

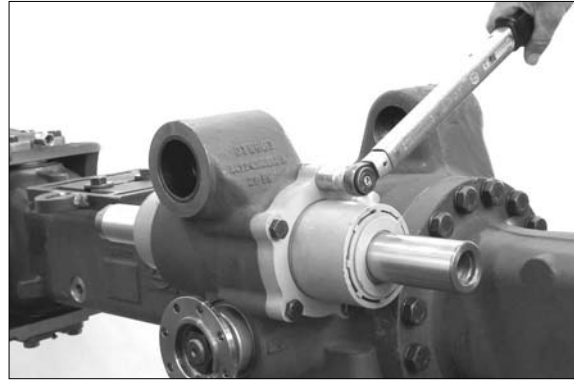

17W7A8FA179

(16) If required - preassemble both tie rods.

1 = Axial joint

2 = Ball joint with tube

3 = Clamp

Do not tighten the screw of the clamp before setting the track.

Tightening torque (M 12 × 1.5) .....  
 .....  $M_A = 75\text{Nm}$

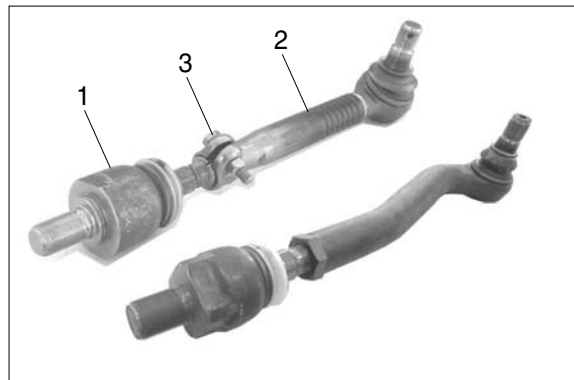

17W7A8FA180

(17) Provide connection - axial joint / piston rod (appr. 3 threads) - with locking agent (Loctite-No. 243).

※ Observe installation position of tie rods - offset to show towards knuckle housing / axle housing (see arrow).

Fix both tie rods on steering.

Tightening torque (M 30 × 1.5) .....  
 .....  $M_A = 450\text{Nm}$

(S) Socket spanner 5870 656 100  
 (Wrench size 55)

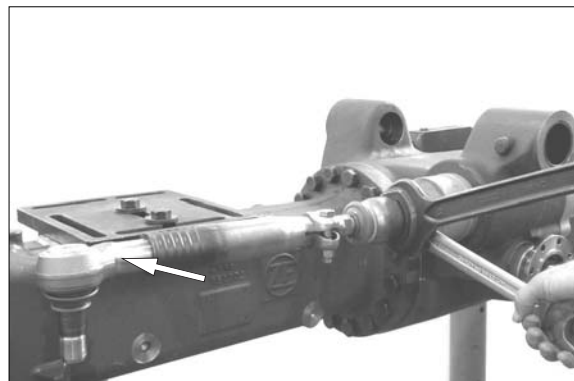

17W7A8FA181

(18) Hang up tie rod and fix with new locking nut.

Use locking nut just once for assembly.

Tightening torque (M 27 × 1.5) .....  
 .....  $M_A = 100\text{Nm} + 200^\circ$

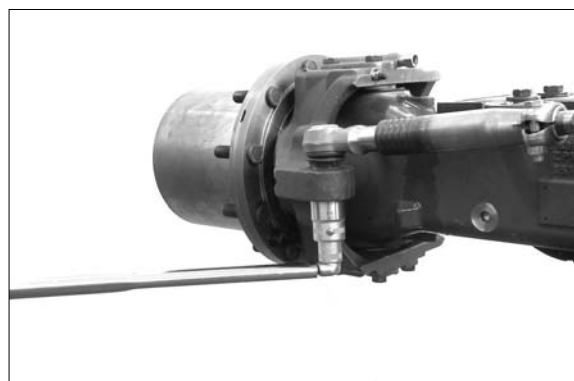

17W7A8FA182

**(19) Steering setting and checking :**

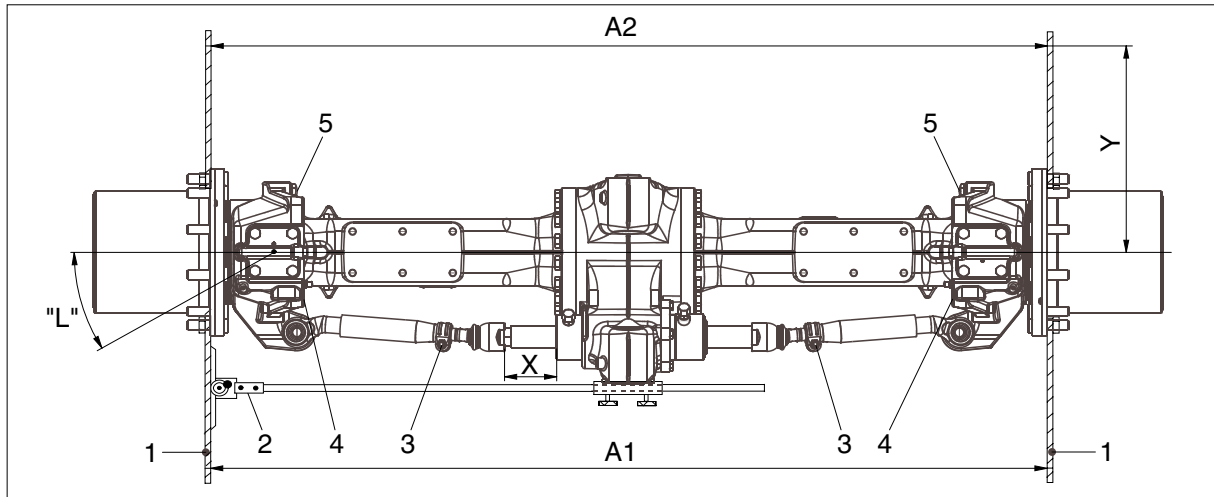

17W7A8FA183

- |                      |              |  |
|----------------------|--------------|--|
| 1 = Straightedge     | 5870 200 029 | 4 = Stop screw with stop washer (internal) |
| 2 = Measuring device | 5870 200 033 | 5 = Stop screw (outer)                     |
| 3 = Clamp            |              |  |

**(20) Basic track setting :**

Bring piston rod to central position - Dimension **X**

Determine dimension = **X** (measure from face/steering cylinder to face / axial joint).

- |  |             |
|--|-------------|
| Piston (rod) stop / l - h in cylinder Dimension I e.g. ....  | 215mm       |
| Piston (rod) stop / r - h in cylinder Dimension II e.g. .... | - 25mm      |
| Result .....   | = 190mm ÷ 2 |
| Dimension <b>X</b> e.g. ....                                 | = 95mm      |

※ During track setting, the axial position of the piston rod must not be changed any more.

Mount straightedges (1) in horizontal and central axis position.

Fix measuring device (2) on input flange.

Loosen nut/clamp (3) and set length of tie rod (axial joint) until the measuring device (2) indicates 0° (corresponds to a track setting of zero mm).

※ Make setting on both sides.

- |                      |              |
|----------------------|--------------|
| (S) Measuring device | 5870 200 033 |
| (S) Straightedges    | 5870 200 029 |

Check track setting (0°) :

Determine dimension **A1**.

Rotate both outputs by 180° - dimension **A2** must be equal to dimension **A1**.

Dimension **Y** = distance - wheel center to rim flange.

※ For a toe - in and toe - out setting, which might be required, stick to the vehicle manufacturer's specification.

Afterwards fix both tie rods/axial joint again by means of a clamp (3).

Tightening torque (M12 × 1.5) .....  $M_A = 75\text{Nm}$

**(21) Steering angle setting**

※ Set steering angle - not before track setting is completed.

Set steering angle always on the curve inner output side.

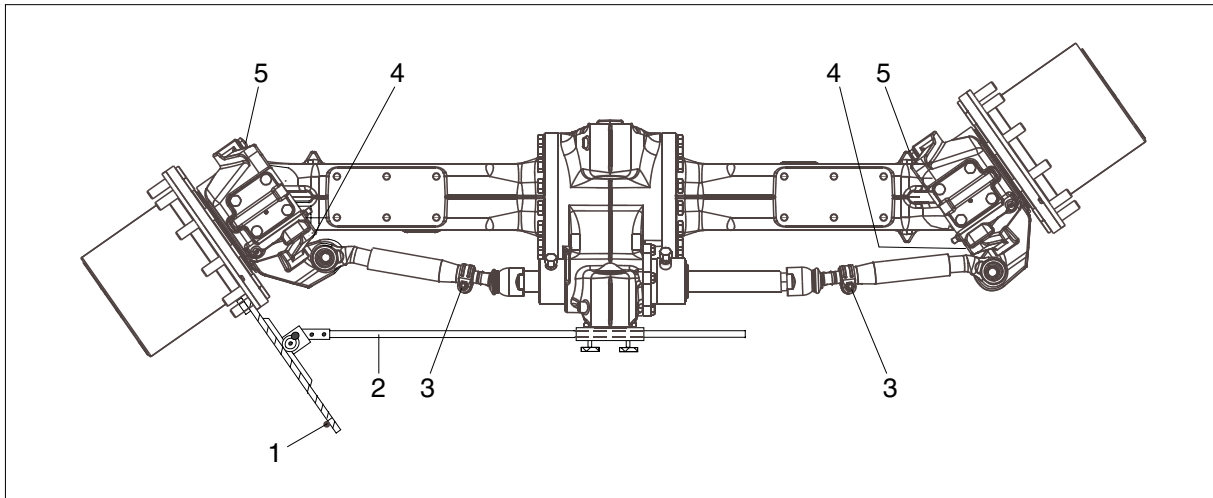

17W7A8FA184

Slew output until the required steering angle is achieved on the measuring device (2 / sketch FA 184)

(Measuring device must have parallel contact with the straightedge (1 / sketch FA184).

※ Take the value of the steering angle **L** to be set (see sketch FA183) from the vehicle manufacturer's specification.

Set inner stop through setting screw (4) with stop washer (s = optional).

Tightening torque (M18 / 10.9) .....  $M_A = 390Nm$

Fix outer stop through setting screw (5) with counter nut.

Tightening torque (M18) .....  $M_A = 170Nm$

Make setting on both output sides.

(S) Measuring device                      5870 200 033

**(22) Check leakage of steering**

Test pressure : 250bar

Test medium : motor oil SAE 10W  
SAE85W-90 with LS-ADDITIVE

Connect HP pump,  
Build up test pressure P = max. 250bar  
(bleed pressure chamber).  
Close locking valve of HP pump.

A 5bar pressure drop is permissible during a test duration of 20 sec..

An outer leakage is not permissible.

Make leakage test of steering in both steering directions.

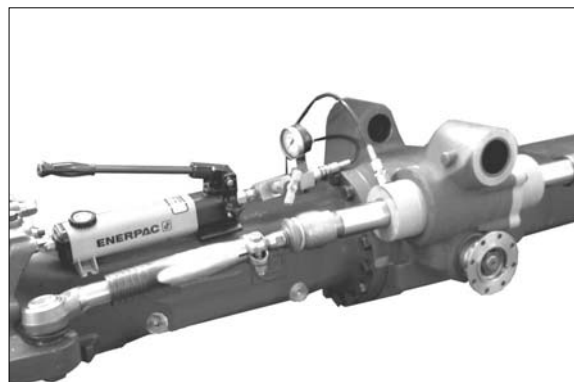

17W7A8FA185

(S) HP pump                                      5870 287 007

(S) Threaded joint GE12PLM                0662 561 931

(S) Measuring fitting                         5870 950 139

**(23) Oil drain-, oil filler and oil control plugs and grease lubrication points :**

Mount oil drain plug with solenoid insert (1) - fitted with new O-ring.

Mount oil filler and oil control plug (2) - fitted with new O-ring.

Tightening torque (M36 × 1.5) .....  
.....  $M_A = 50\text{Nm}$

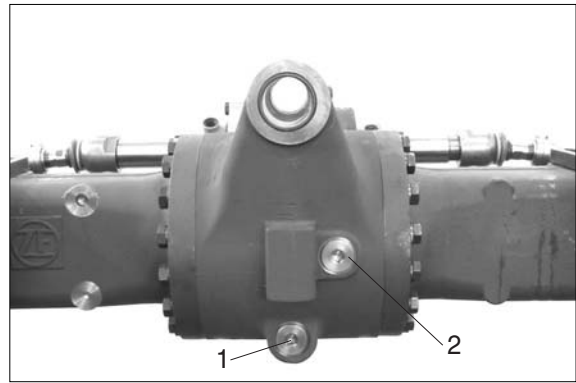

17W7A8FA186

(24) Mount oil drain, oil filler and oil control plug with solenoid insert (3) - fitted with new O-ring - in both outputs.

Tightening torque (M36 × 1.5) .....  
.....  $M_A = 50\text{Nm}$

※ Prior to putting the axle into operation, observe operator's manual and service manual.

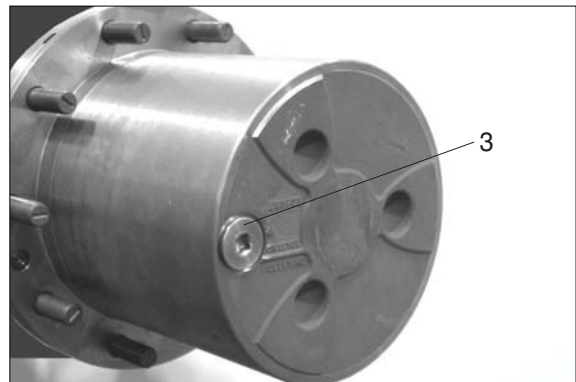

17W7A8FA187