

GROUP 5 SWING DEVICE

1. REMOVAL AND INSTALL OF MOTOR

1) REMOVAL

- (1) Lower the work equipment to the ground and stop the engine.
- (2) Operate the control levers and pedals several times to release the remaining pressure in the hydraulic piping.
- (3) Loosen the breather slowly to release the pressure inside the hydraulic tank.

▲ Escaping fluid under pressure can penetrate the skin causing serious injury.

※ When pipes and hoses are disconnected, the oil inside the piping will flow out, so catch it in oil pan.

- (4) Disconnect hose assembly (2).
- (5) Disconnect pilot line hoses (3,4,5,6,7,8,9).
- (6) Sling the swing motor assembly (1) and remove the swing motor mounting bolts (10).

※ Motor device weight : 250kg (550lb)

- (7) Remove the swing motor assembly.

※ When removing the swing motor assembly, check that all the piping have been disconnected.

2) INSTALL

- (1) Carry out installation in the reverse order to removal.
- (2) Bleed the air from the swing motor.
 - ① Remove the air vent plug.
 - ② Pour in hydraulic oil until it overflows from the port.
 - ③ Tighten plug lightly.
 - ④ Start the engine, run at low idling and check oil come out from plug.
 - ⑤ Tighten plug fully.
- (3) Confirm the hydraulic oil level and check the hydraulic oil leak or not.

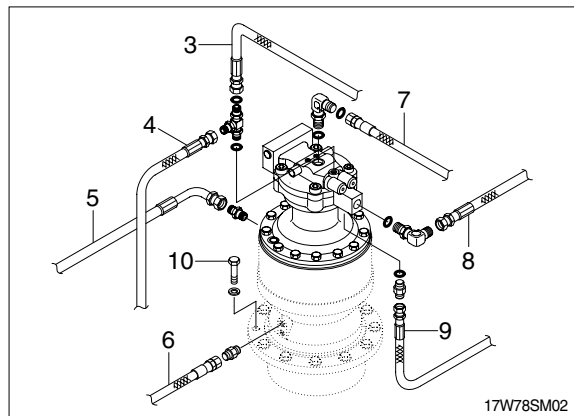
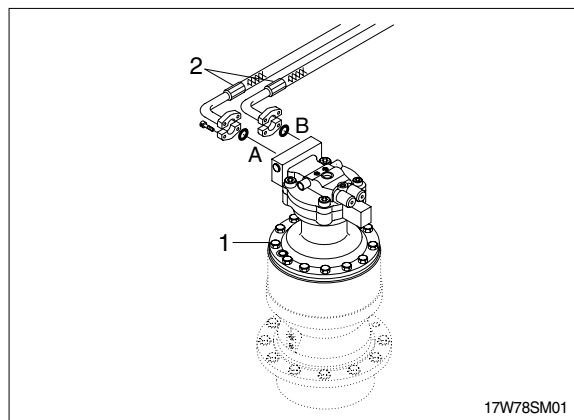

2. DISASSEMBLY AND ASSEMBLY OF SWING MOTOR

1) STRUCTURE

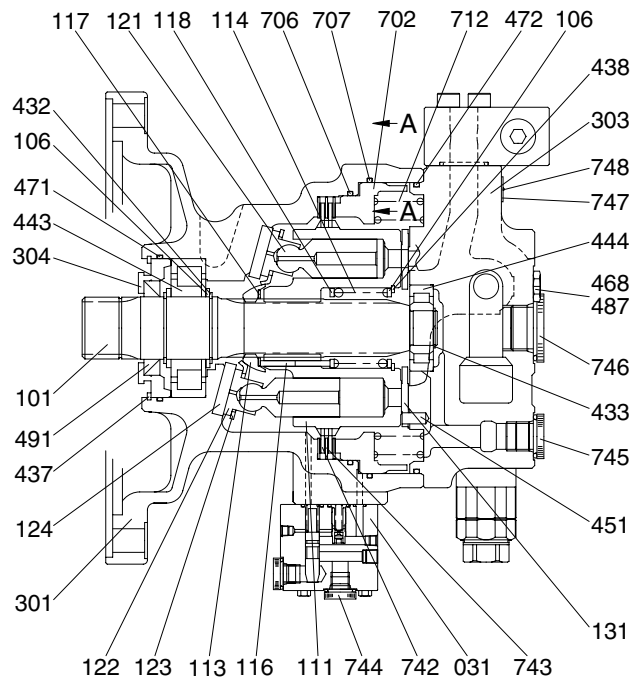

SECTION A-A

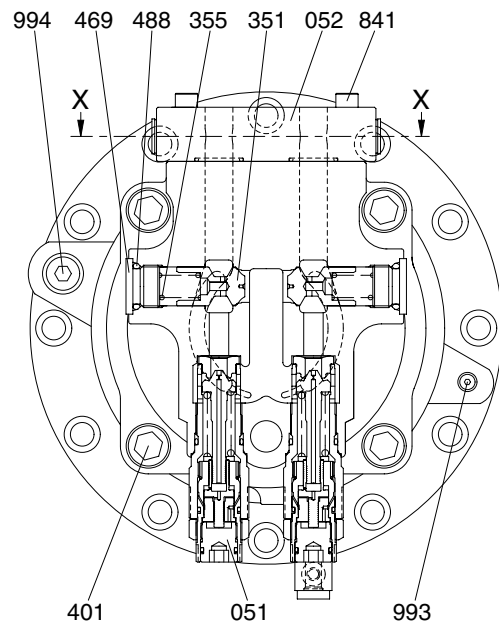

SECTION X-X

17W72SM02

031 Brake valve	122 Shoe	471 O-ring
051 Relief valve	123 Retainer	472 O-ring
052 Reactionless valve assy	124 Shoe plate	485 O-ring
053 Valve	131 Valve plate	487 O-ring
054 Block	301 Casing	488 O-ring
055 Plug	303 Casing	491 Oil seal
056 Back up ring	304 Front cover	702 Piston
057 O-ring	351 Plunger	706 O-ring
058 Plug	355 Spring	707 O-ring
059 O-ring	401 Hexagon socket bolt	712 Brake spring
060 O-ring	432 Snap ring	742 Friction plate
101 Drive shaft	433 Snap ring	743 Separate plate
106 Spacer	437 Snap ring	744 Plug
111 Cylinder block	438 Snap ring	745 Plug
113 Bushing	443 Roller bearing	746 Plug
114 Spring	444 Roller bearing	841 Hexagon socket bolt
116 Push rod	451 Spring pin	993 Plug
117 Spacer	464 Plug	994 Plug
118 Spacer	468 Plug	
121 Piston	469 Plug	

2) DISASSEMBLY

- (1) Lift the motor out. Clean the motor in kerosene and dry with compressed air.
 - ※ To avoid dust inside the motor, mask all the ports of the motor with tapes.

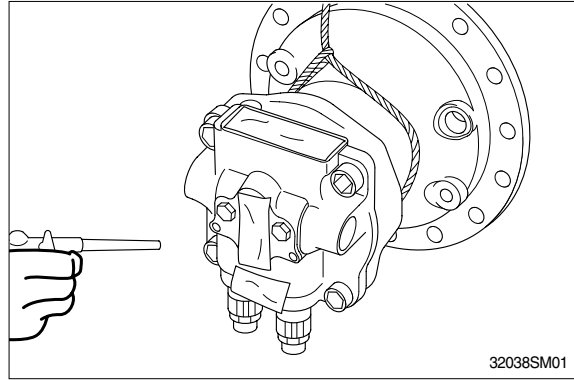

- (2) Loosen the drain plug to discharge oil in the casing (301).

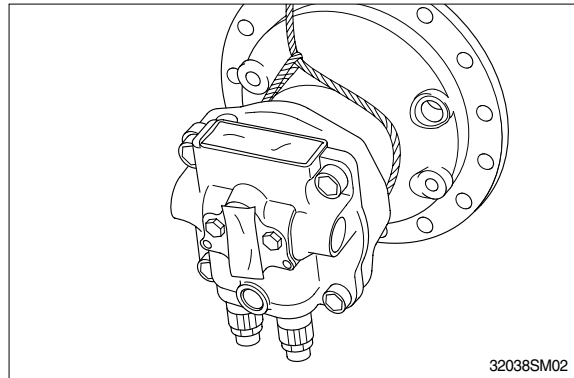

- (3) Fix the drive shaft (101) on the workbench with the end of output shaft down. Put matching marks on casing (301) and valve casing (303) for easy reassembly.

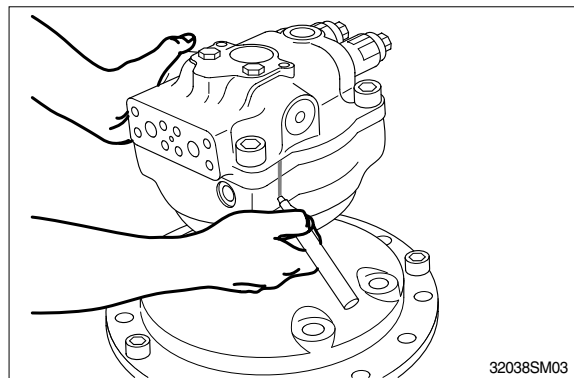

- (4) Remove the valve (052).

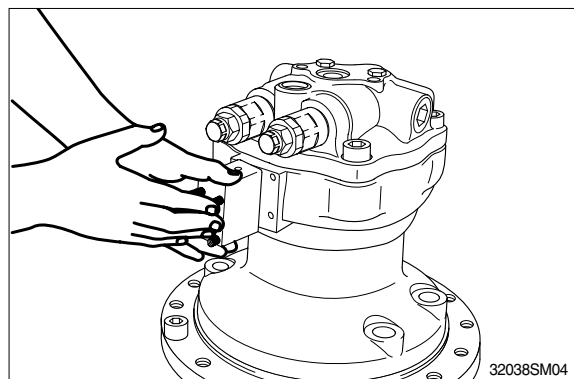

- (5) Remove the relief valve (051) from valve casing (303).

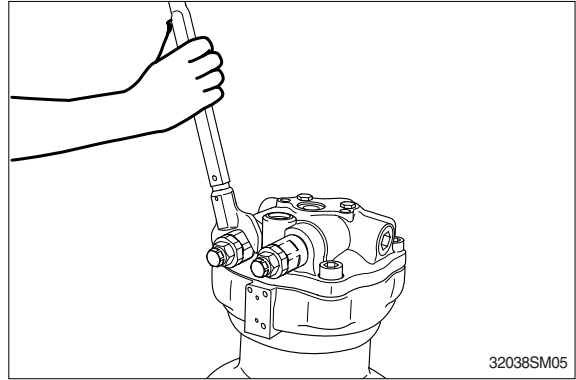

- (6) Remove plug (469) from valve casing (303) and spring (355), plunger (351).
※ Be careful not to damage the plunger seat assembly.

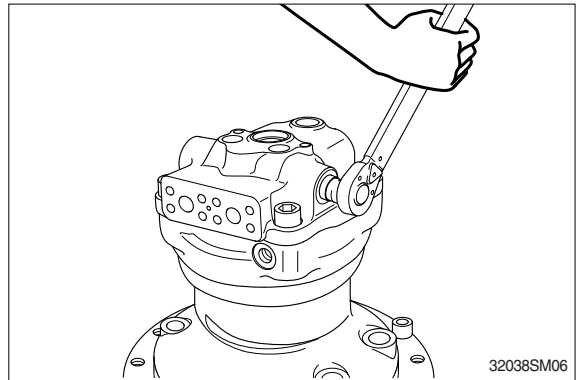

- (7) Remove valve casing (303) from casing (301). Then, remove the valve plate (131) from valve casing (303) with care.

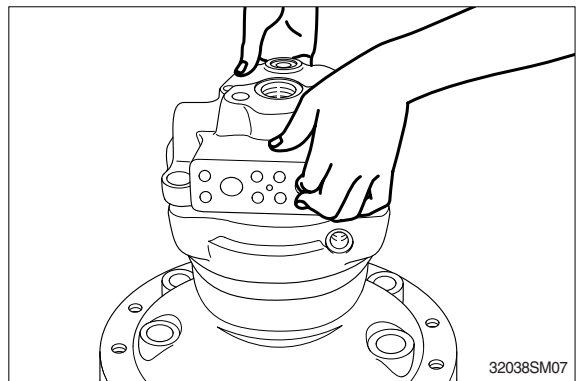

- (8) Remove the brake spring (712) from brake piston (702).

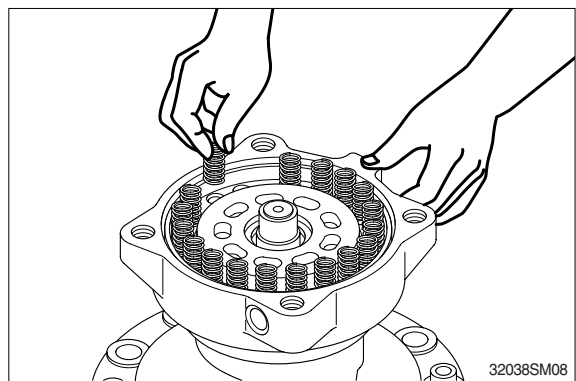

- (9) Remove brake piston (702) from casing (301).

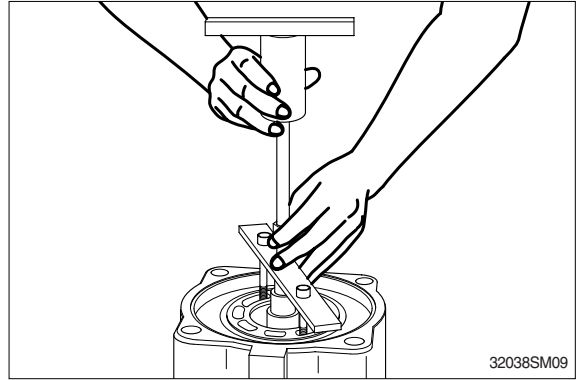

- (10) Remove the cylinder (111) from the output shaft (101) with the motor positioned horizontally. Remove piston (121), retainer (123), bushing (113), spacer (117) and shoe plate (124).

※ If shoe plate would not removed easily, try again after procedure (14).

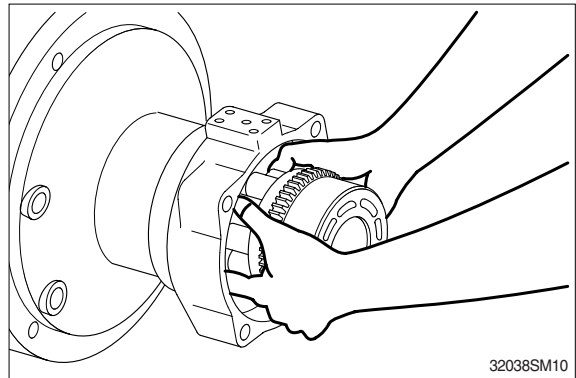

- (11) Remove friction plate (742) and separate plate (743) from casing (301).

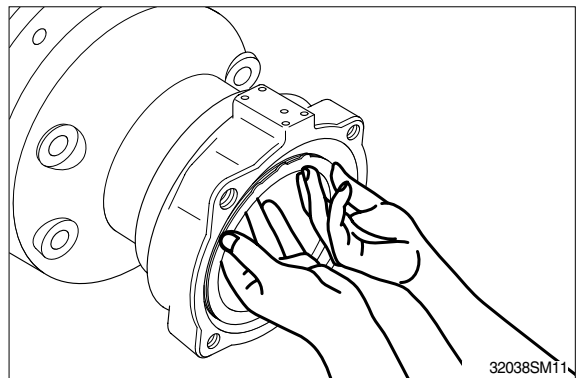

- (12) Remove snap ring (437) with plier and remove the front cover (304) from casing (301).

※ Front cover could be removed with sliding shaft if necessary.

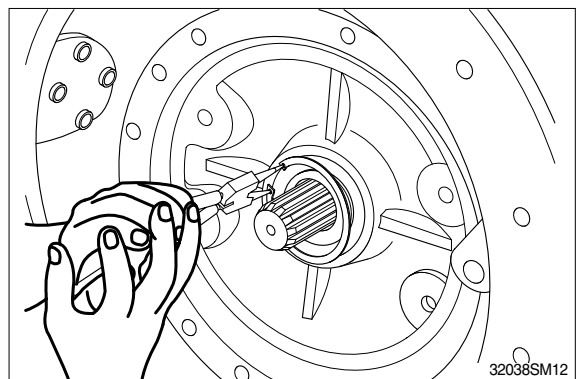

(13) Remove drive shaft (101) from casing (301).

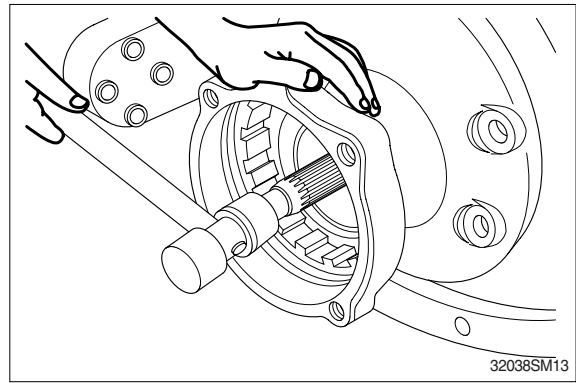

(14) Remove the shoe plate (124) from casing (301).

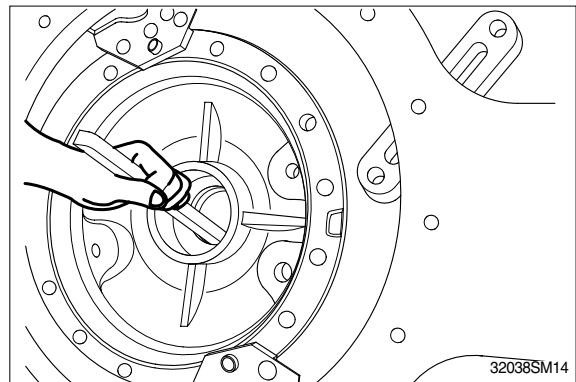

(15) Proceed with following job only when necessary.

- ① Remove the snap ring (432), spacer (106) from drive shaft (101) and remove the cone of roller bearing (443) by press.

※ Do not reuse bearings.

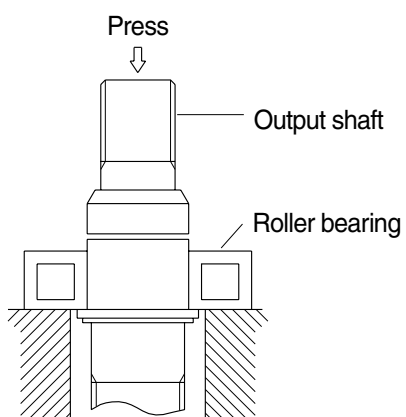
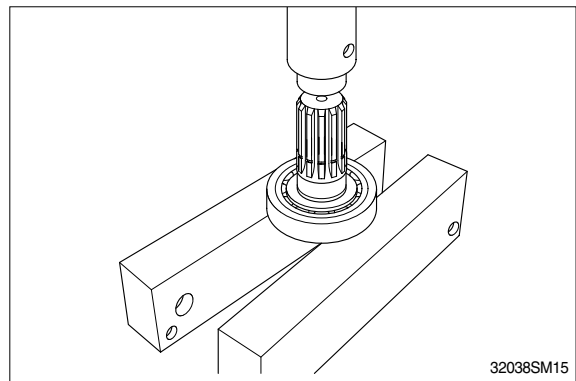

- ② Remove oil seal (491) from front cover (304).

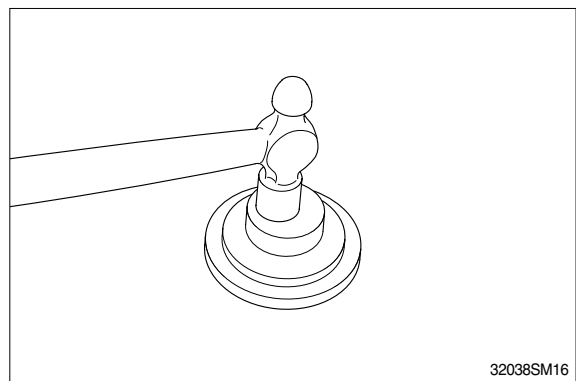

- ③ Remove the roller bearing (444) from the valve casing (303) by using slide hammer bearing puller.

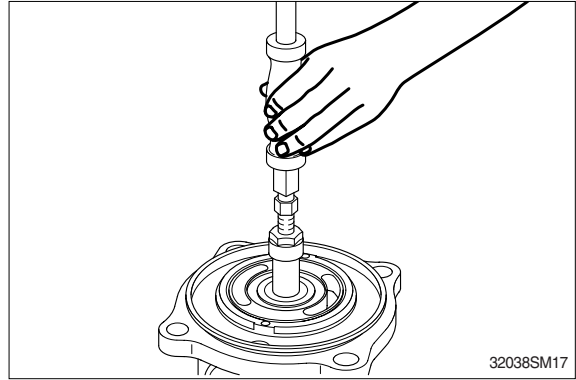

- ④ When disassembling the relief valve, release the plug (3). Remove the piston (7), spring seat (9), spring (8) and plunger (6) with the body (1) downwards.

※ Do not release the lock nut (15).

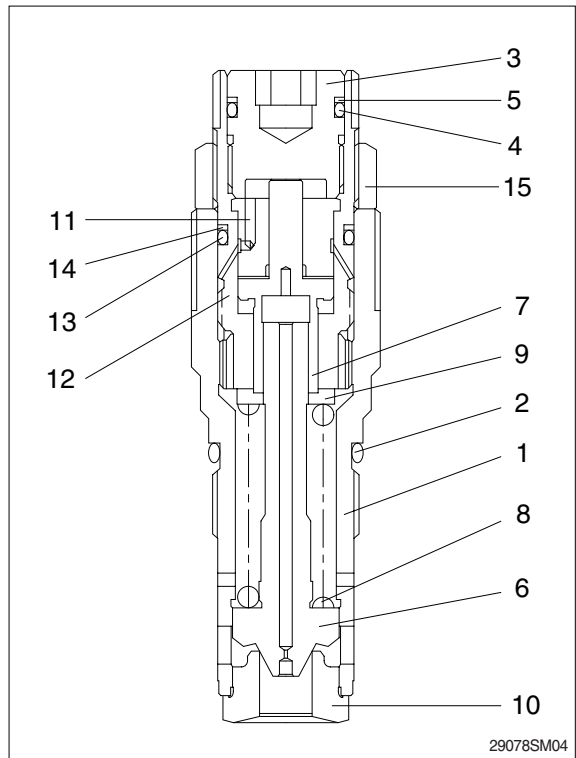

This completes disassembly.

3) ASSEMBLY

Do the reassembly in the reverse procedure of the disassembly.

- (1) Place the casing (301) on the workbench with the valve casing (303) downward.

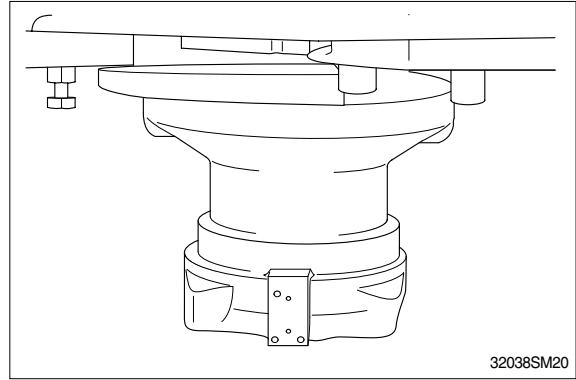

- (2) When reassembling the roller bearing, install the snap ring (432), and spacer (106) to the drive shaft (101). Insert the collar and cone of the roller bearing (443). Install the spacer (106) and stop ring (432). Install stop ring (433) to the output shaft (101) by heating the cone of the roller bearing (444).

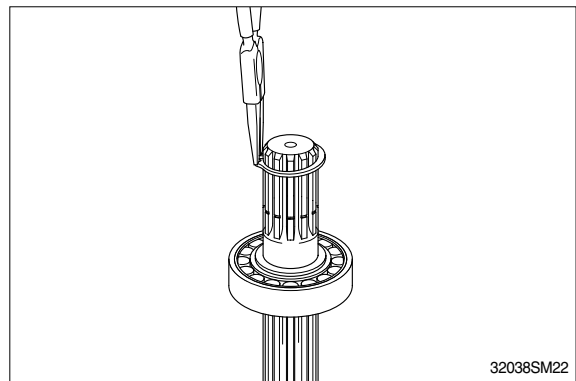
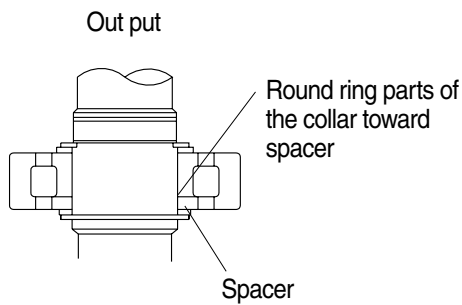
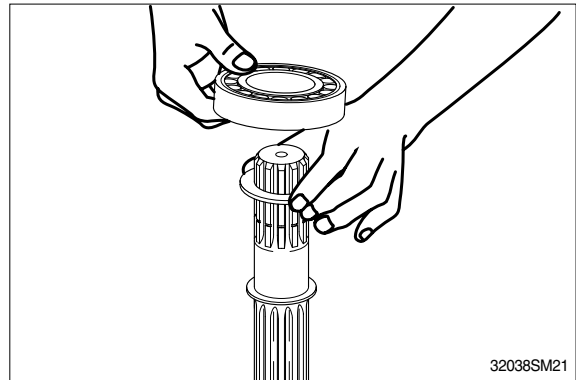

- (3) Insert the drive shaft (101) into the casing (301) with the end of output shaft upward and tap the outer race of roller bearing with the hammer.

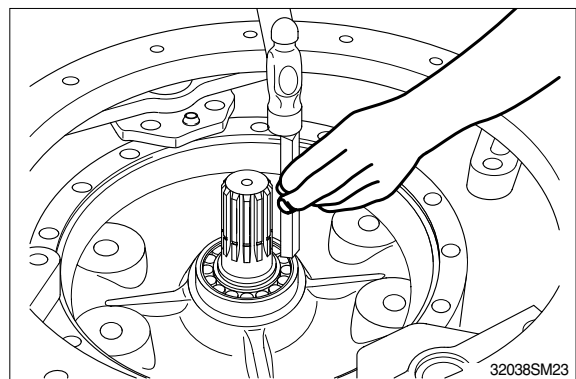

(4) Tack O-ring (471) to the casing (301).

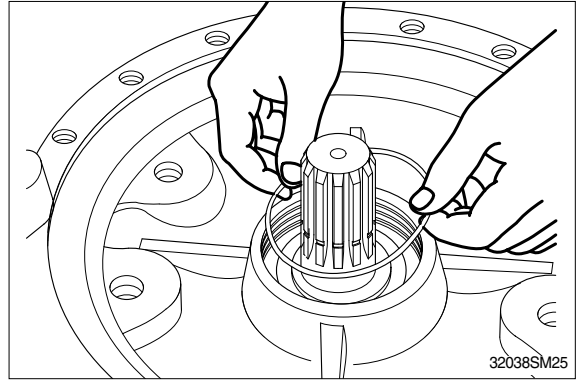

(5) Reassemble the front cover (304) to the casing (301).

※ Apply grease to the rib of oil seal to avoid damage to the rib.

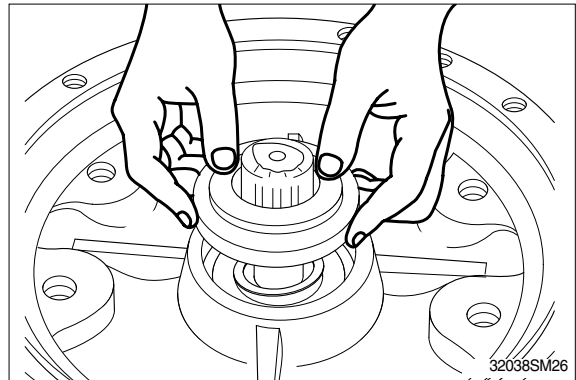

(6) Install the snap ring (437) to the casing (301).

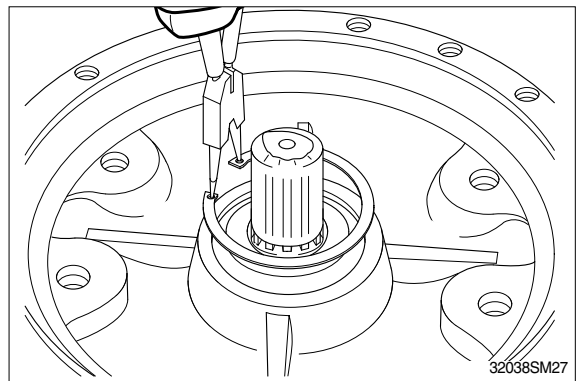

(7) Insert the shoe plate (124) with the casing (301) position horizontally.

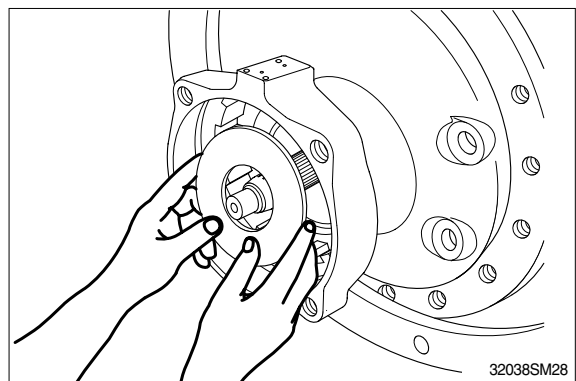

(8) Insert the push rod (116) into the cylinder (111). Place the bushing (113) assembled with spacer (117) onto the cylinder.

※ Insert two push rods in each hole.

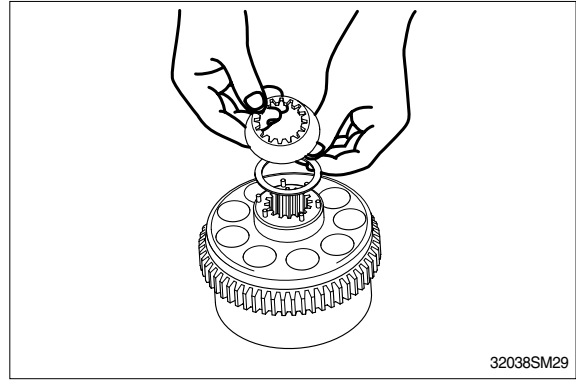

(9) Install the piston sub-assembly (121, 122) to the retainer (123).



(10) Reassemble the piston assembly (121, 122) to the cylinder (111).

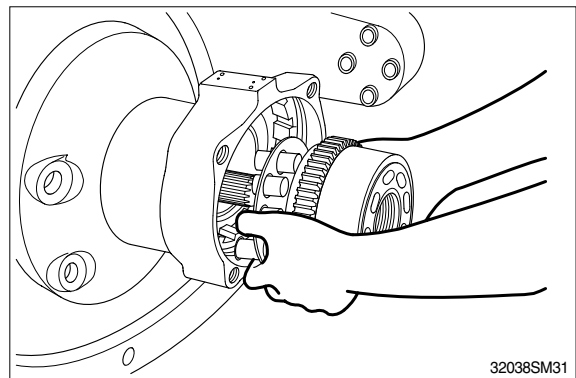

(11) Place the casing (301) under the front cover (304) and reassemble 3 sheets of separate plate (743) and then 2 sheets of friction plate (742) to the casing (301).

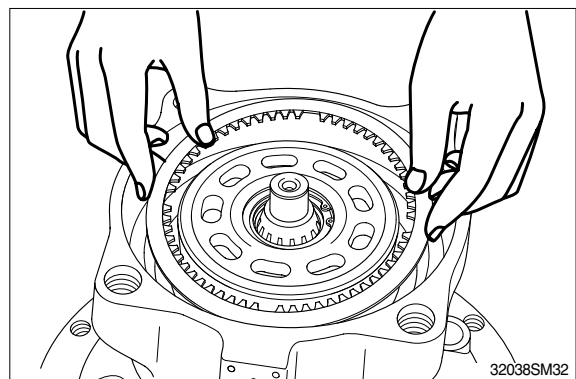

(12) Insert O-ring (706, 707) inside the casing (301).

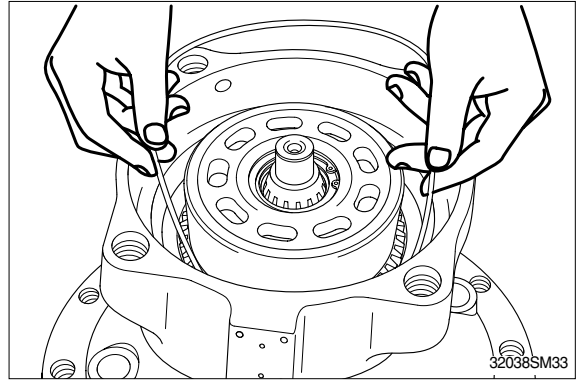

(13) Reassemble brake piston (702) to the casing (301).

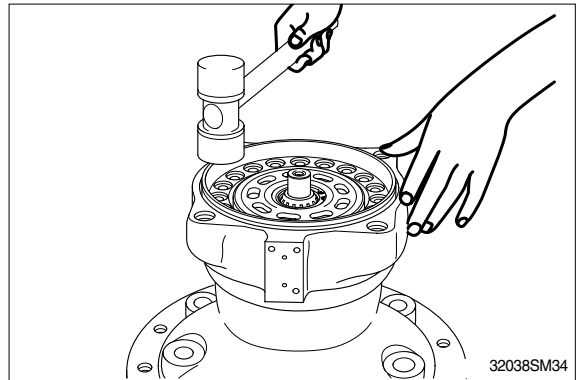

(14) Reassemble brake spring (712) to the brake piston (702).

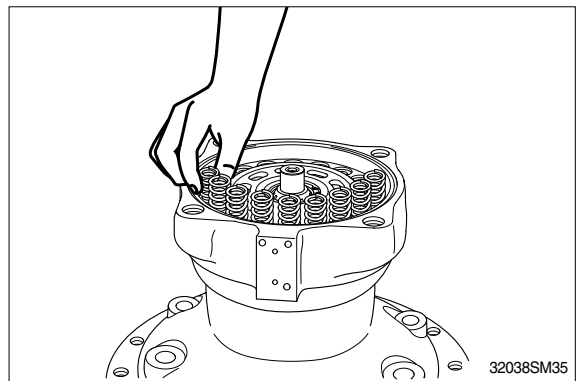

(15) When assembling the roller bearing (444), insert the roller bearing (444) into valve casing (303) by hammering.

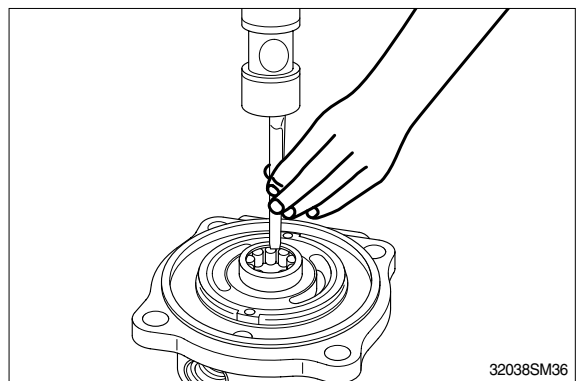

- (16) Reassemble valve plate (131) to the valve casing (303) and reassemble O-ring (472).

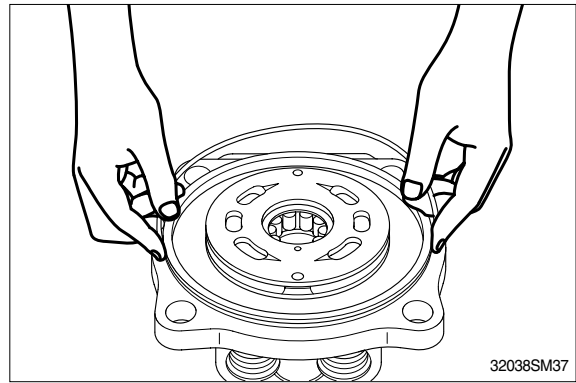

- (17) Connect the valve casing (303) with the casing (301) and tighten the hexagon screw (401).

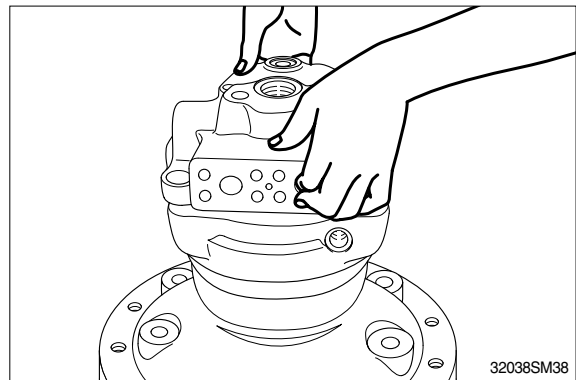

- (18) Insert plunger (351) and spring (355) in the valve casing and install O-ring (488). Tighten plug (469) to the valve casing.

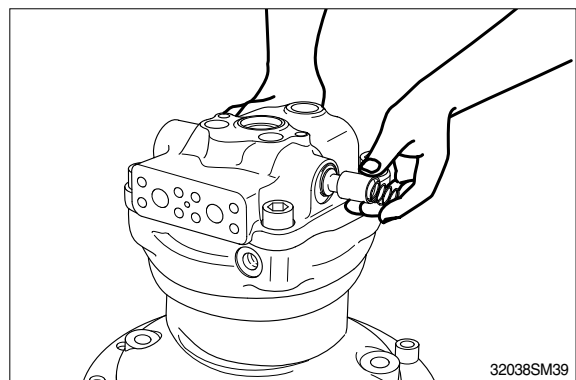

- (19) Insert O-rings (051-1) to the relief valve (051) and reassemble them to valve casing (303).

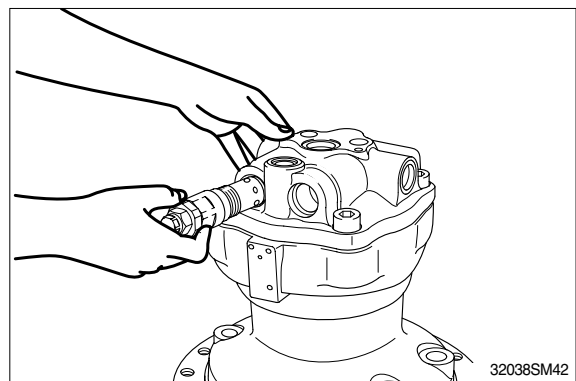

(20) Tighten the plug (468) to valve casing (303) with O-ring (487) and tighten the plug (464) to casing (301) with O-ring (485).

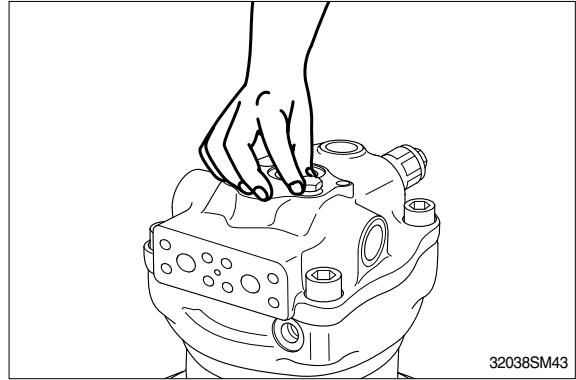

(21) Connect the valve casing (303) with the casing (301).

This completes assembly.

3. REMOVAL AND INSTALL OF REDUCTION GEAR

1) REMOVAL

- (1) Remove the swing motor assembly.
For details, see **removal of swing motor assembly**.
- (2) Sling reduction gear assembly (1) and remove mounting bolts (2).
- (3) Remove the reduction gear assembly.
 - Reduction gear device weight : 180kg
(396lb)



2) INSTALL

- (1) Carry out installation in the reverse order to removal.
 - Tightening torque : $49.2 \pm 66.6 \text{kgf} \cdot \text{m}$
($356 \pm 481 \text{lb} \cdot \text{ft}$)

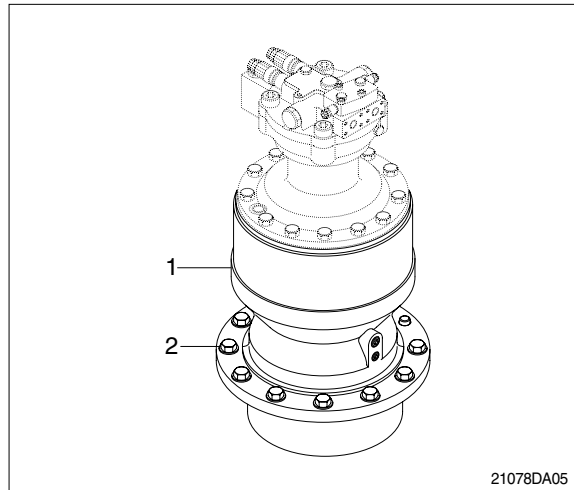

4. DISASSEMBLY AND ASSEMBLY OF REDUCTION GEAR

1) STRUCTURE

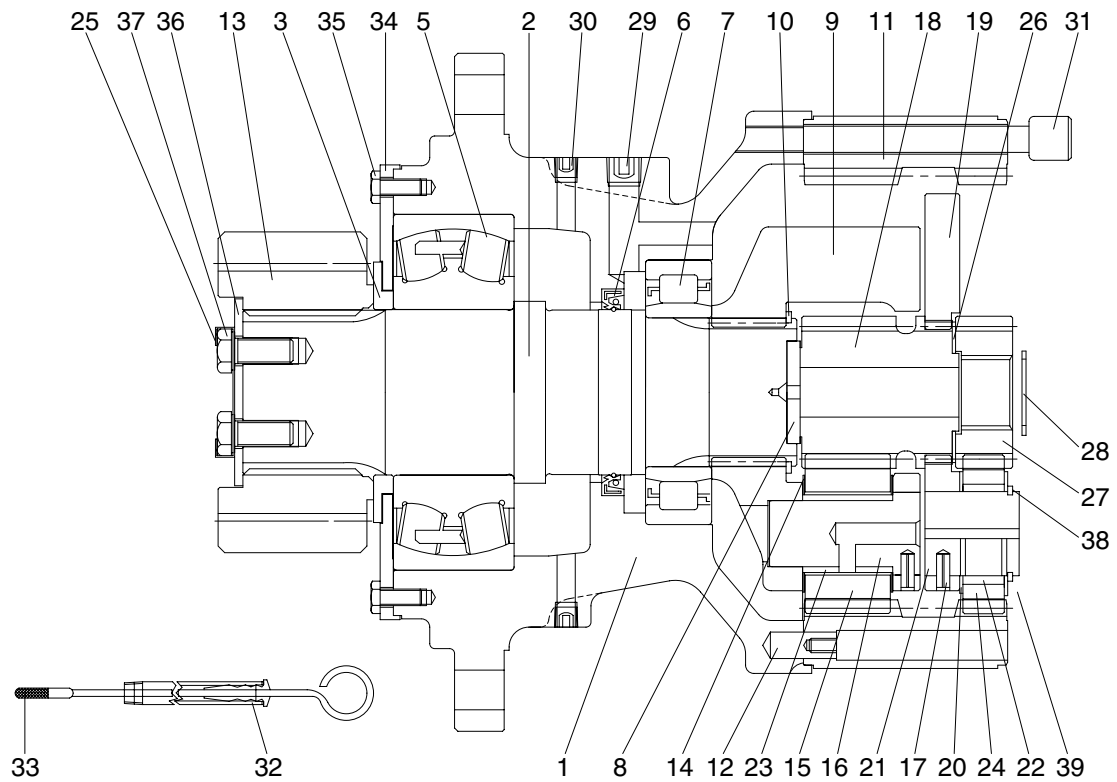

17W72SM03

1	Casing	15	Planet gear 2	28	Stop ring
2	Drive shaft	16	Pin 2	29	Plug
3	Spacer	17	Spring pin	30	Plug
5	Roller bearing	18	Sun gear 2	31	Socket bolt
6	Oil seal	19	Carrier 1	32	Gauge pipe
7	Roller bearing	20	Side plate 1	33	Gauge bar
8	Thrust plate	21	Pin 1	34	Cover plate
9	Carrier 2	22	Needle cage	35	Hexagon bolt
10	Stop ring	23	Bushing 2	36	Lock plate
11	Ring gear	24	Planet gear 1	37	Hexagon bolt
12	Knock pin	25	Lock washer	38	Stop ring
13	Pinion gear	26	Side plate 3	39	Side plate 2
14	Thrust washer	27	Sun gear 1		

2) DISASSEMBLY

- (1) Spread off the 4 corners of lock washer (25) with a tool.
 - ※ Do not reuse lock washer (25).
- Loosen the hexagon bolts (37) and then remove lock washer (25) and lock plate (36) from the pinion gear (13).
- Remove pinion gear (13) and spacer (3) from the drive shaft (2).
- Remove cover plate (34) from the casing (1) by loosening the hexagon bolts (35).

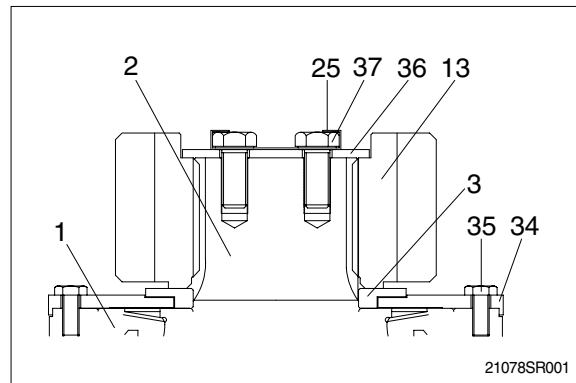

- (2) Remove gauge bar (33) and gauge pipe (32) from the swing motor casing.
- ※ Pour the gear oil out of reduction gear into the clean bowl to check out the friction decrease.

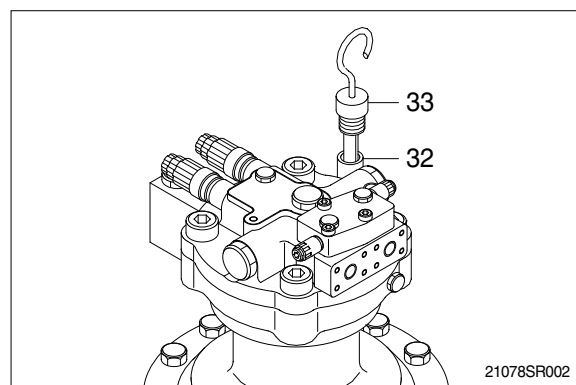

- (3) Loosen the socket bolts (31) to separate swing motor from reduction gear.

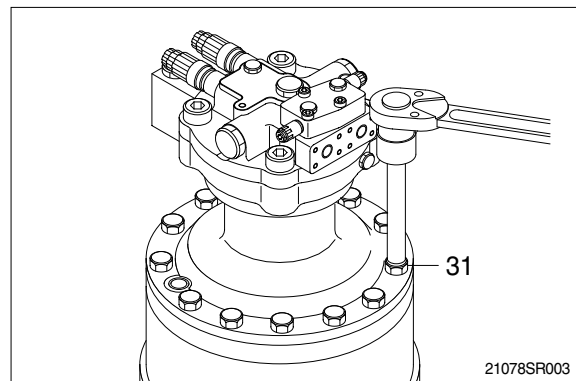

- (4) Tighten 3 M16 eye bolts to the ring gear (11) and then lift the ring gear (11) out of the casing (1).

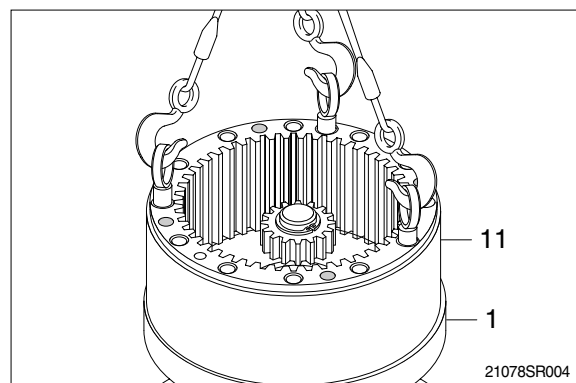

- (5) Remove stop ring (28) and then sun gear 1 (27).

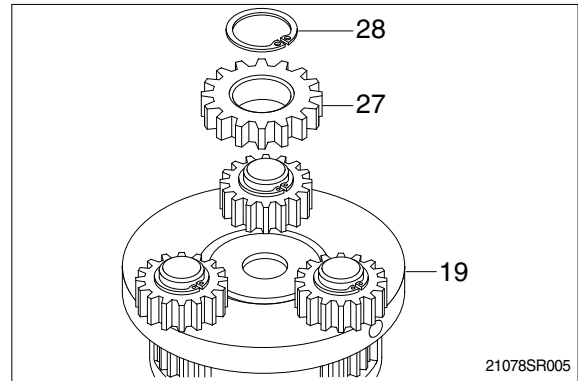

- (6) Tighten two M10 eye bolts to carrier 1 (19) and lift up and remove carrier 1 (19) as subassembly.

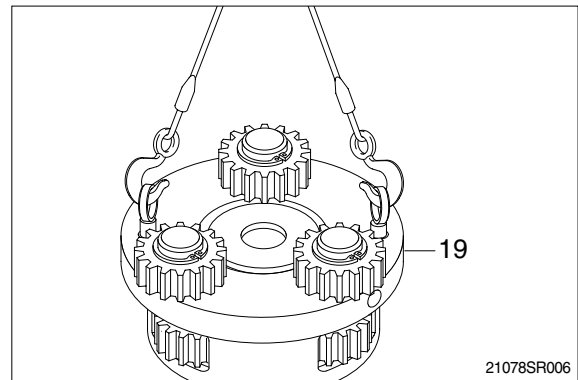

- (7) Disassembling carrier 1 (19) assembly.

- ① Remove stop ring (38).
 - ② Remove side plate 2 (39), planet gear 1 (24), needle cage (22), side plate 1 (20) and side plate 3 (26) from the carrier.
 - ③ Using M8 solid drill, crush spring pin (17) so that the pin 1 (21) can be removed by hammering.
 - ④ Remove side plate 3 (26) from carrier 1 (19).
- ※ Do not reuse spring pin (17).
 - ※ Do not remove pin 1 (21), carrier 1 (19) and spring pin (17) but in case of
 - ※ replacement.
- Put matching marks on the planet gear 1 (24) and the pin 1 (21) for easy reassembly.

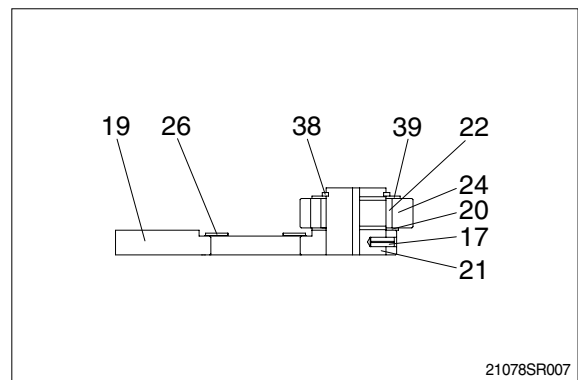

(8) Remove sun gear 2 (18) and thrust washer (14).

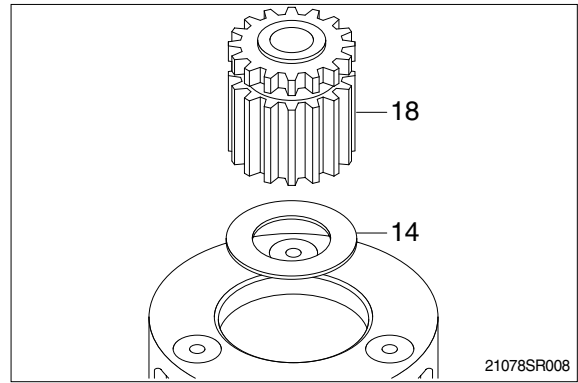

(9) Remove carrier 2 (9) assembly from casing (1).

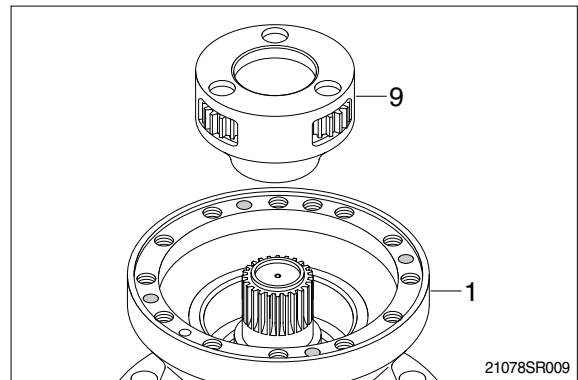

(10) Disassembling carrier 2 (9) assembly

- ① Using M8 solid drill, crush spring pin (17) so that the pin 2 (16) can be removed.
※ Do not reuse spring pin (17).
- ② Remove pin 2 (16), planet gear 2 (15) and bushing 2 (23) from the carrier 2 (9).
※ Put matching marks on the planet gear 2 (15) and the pin 2 (16) for easy reassembly.
※ Do not disassemble pin 2 (16), carrier 2 (9) and spring pin (17) but in case of replacement.

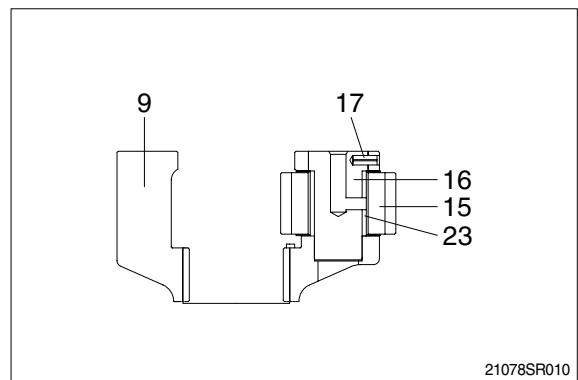

(11) Remove thrust plate (8) and stop ring (10) from the drive shaft (2).

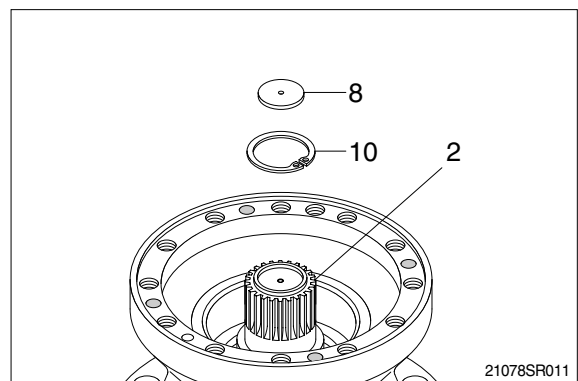

- (12) Remove drive shaft (2) with roller bearing (7) and oil seal (6) assembled.
Remove knock pin (12) from the casing (1).

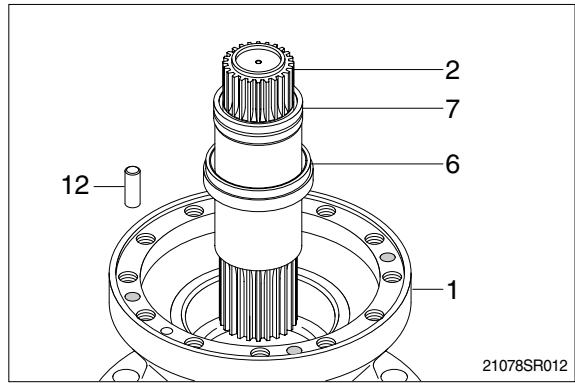

- (13) Remove roller bearing (7) and oil seal (6) from the drive shaft (2).
※ Do not reuse oil seal (6) once removed.

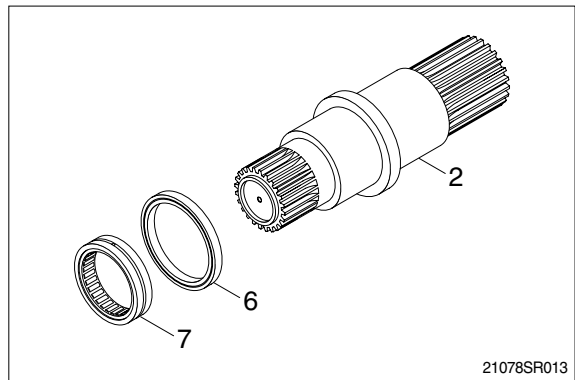

- (14) Using the bearing disassembly tool, remove roller bearing (5).

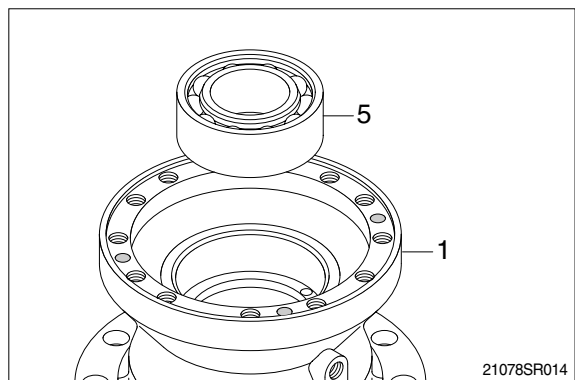

- (15) Remove plugs (29, 30) from the casing (1).

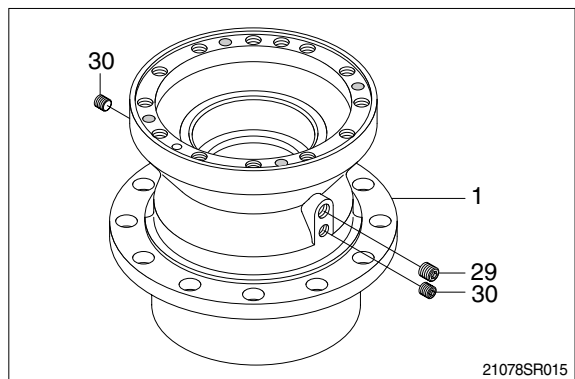

3) ASSEMBLY

- (1) Assemble roller bearing (5) inside the casing (1).

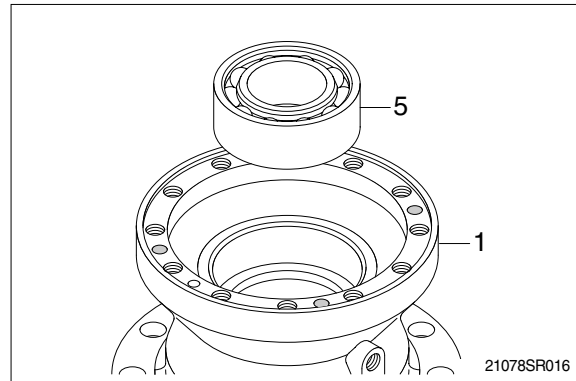

- (2) Assemble the drive shaft (2) into the casing (1) and then install oil seal (6) and roller bearing (7).

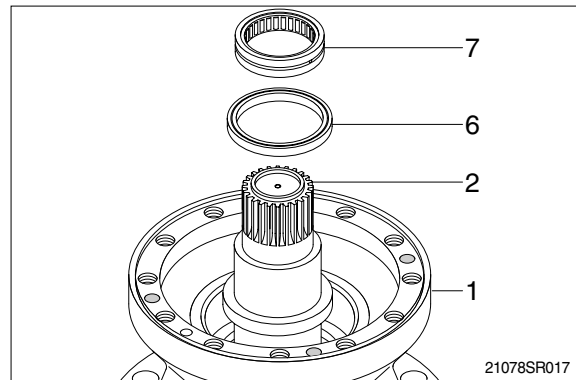

- (3) Install stop ring (10) and thrust plate (8) on top of drive shaft (2).

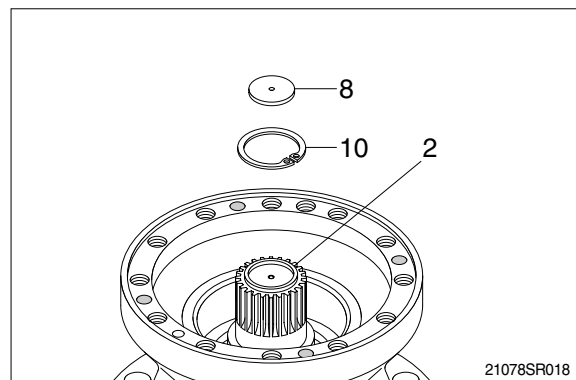

- (4) Assembling carrier 2 (9) assembly.

- ① Install thrust washer (14) inside the carrier 2 (9).
 - ② Install bushing 2 (23) inside the planet gear 2 (15) and then assemble them to the carrier 2 (9).
 - ③ Assemble the pin 2 (16) to the carrier 2 (9) and then press the spring pin (17) by hammering.
 - ④ Punch 2 points of the spring pin (17) lip.
- ※ Take care not to mistake the matching marks of each part.

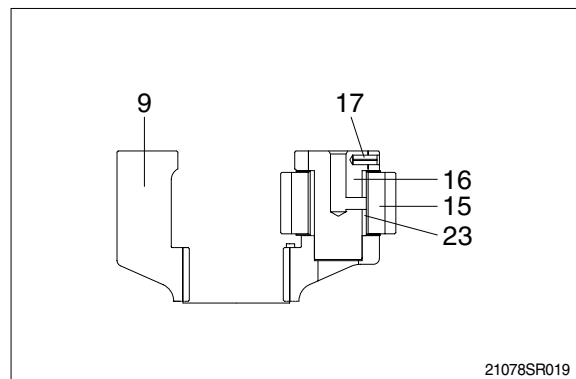

- (5) Assemble carrier 2 (9) assembly correctly to the drive shaft (2).

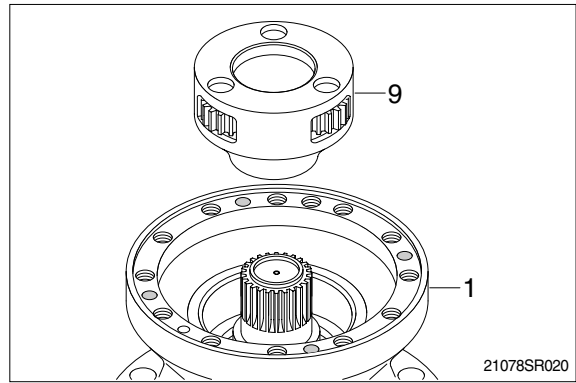

- (6) Assemble sun gear 2 (18) and thrust washer (14) to the center of the carrier 2 (9) assembly.

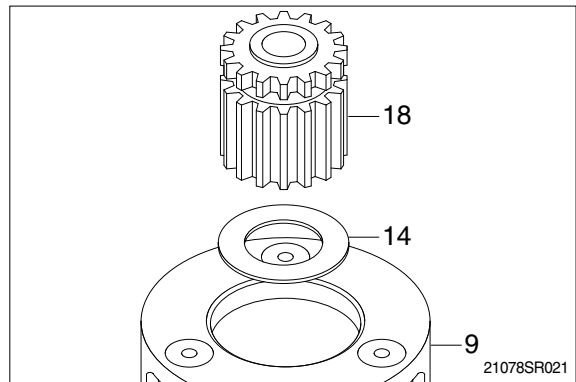

- (7) Assembling carrier 1 (19) assembly.

- ① Assemble the pin 1 (21) to the carrier 1 (19) and then press the spring pin (17) by hammering.
 - ② Punch 2 points of the spring pin's (17) lip.
 - ③ Install side plate 3 (26) onto the center of carrier 1 (19).
 - ④ Install needle cage (22) into the planet gear 1 (24).
 - ⑤ Assemble side plate (20), planet gear 1 (24), side plate 2 (39) and then stop ring (38) to the pin 1 (21).
- ※ Take care not to mistake the matching marks of each part.

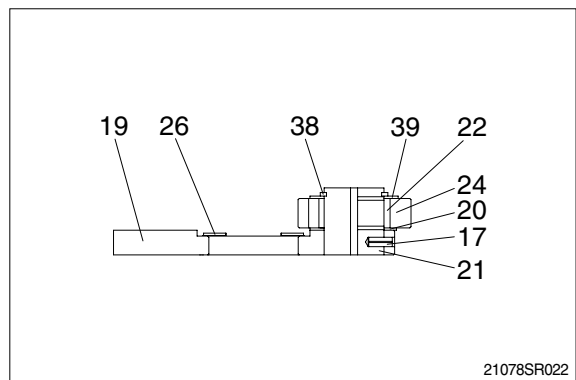

- (8) Install sun gear 1 (27) onto the side plate 3 (26).

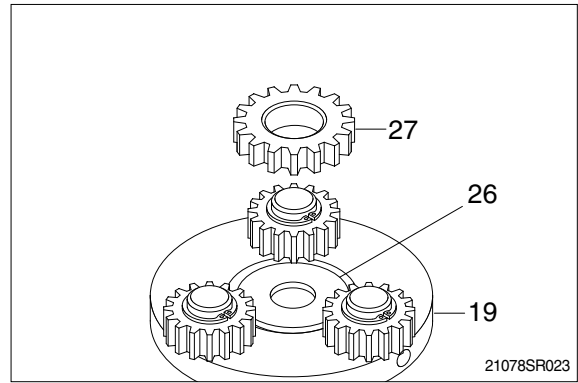

- (9) Assemble carrier 1 (19) assembly onto the carrier 2 assembly.

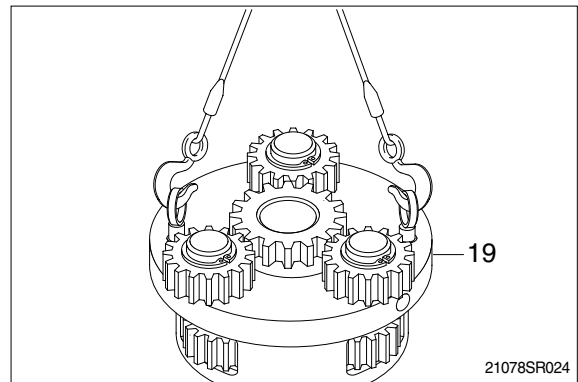

- (10) Apply loctite to the tapped holes of casing
(11) Tighten 3 M16 eye bolts to the ring gear (11) and lift up and then assemble it onto the casing (1).
※ Don't fail to coincide the knock pin (12) holes.

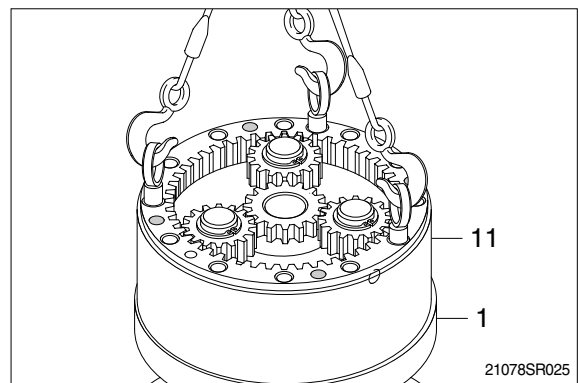

- (12) Hammer 4 knock pins (12) around the ring gear (11).
(13) Assemble stop ring (28) to the drive shaft of the swing motor.

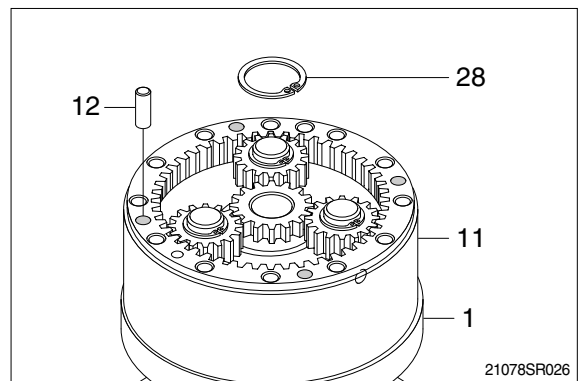

(14) Apply loctite to the tapped holes of the ring gear (11) and then mount swing motor onto the ring gear (11).

※ Don't fail to coincide the gauge bar (33) hole.

(15) Tighten socket bolts (31) around the swing motor assembly.

· Tightening torque : 24kgf · m (173lbf · ft)

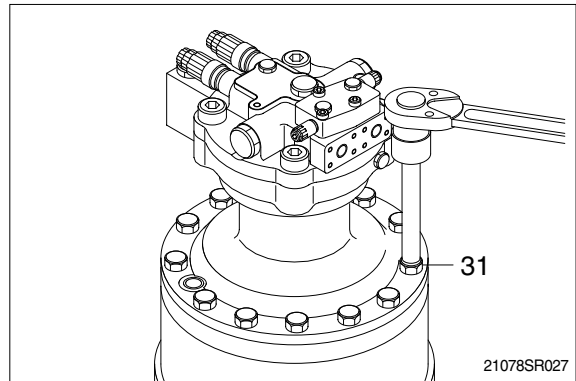

(16) Assemble plugs (29, 30), gauge bar (33) and gauge pipe (32).

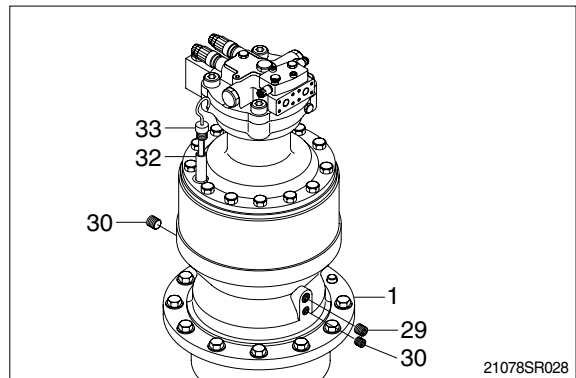

(17) Turn the swing motor assembly upside down and assemble cover plate (34) by tightening the hexagon bolts (35).

Install spacer (3) and pinion gear (13) to the drive shaft (2).

Assemble lock plate (36) on the pinion gear (13).

Assemble 2 lock washers (25) on the lock plate (36) with their 2 hole coincided individually to the tapped holes of drive shaft (2).

Tighten hexagon bolts (37) to the drive shaft (2) and then fold all the lock washer (25) corners over the hexagon bolts (37).

· Tightening torque : 24kgf · m (173lbf · ft)

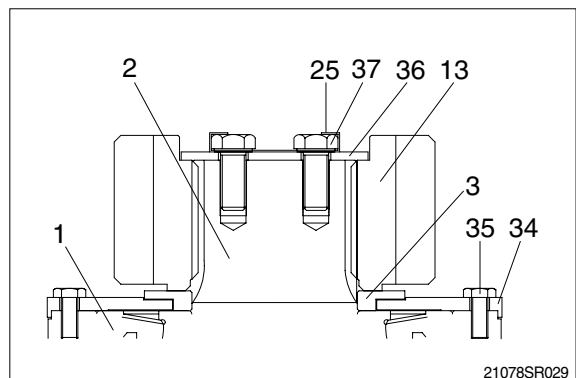

(18) Inject oil into the reduction gear.