

GROUP 3 PUMP DEVICE

1. REMOVAL AND INSTALL

1) REMOVAL

- (1) Lower the work equipment to the ground and stop the engine.
- (2) Operate the control levers and pedals several times to release the remaining pressure in the hydraulic piping
- (3) Loosen the breather slowly to release the pressure inside the hydraulic tank.

▲ Escaping fluid under pressure can penetrate the skin causing serious injury.

- (4) Loosen the drain plug under the hydraulic tank and drain the oil from the hydraulic tank.

· Hydraulic tank quantity : 124 l (32.7 U.S. gal)

- (5) Remove socket bolts (13) and disconnect hoses (1,2).

- (6) Disconnect pilot line hoses (5, 6, 7, 8, 9, 10, 11).

- (7) Remove socket bolts 14 and disconnect pump suction pipe (4).

※ When pump suction tube is disconnected, the oil inside the piping will flow out, so catch it in oil pan.

- (8) Sling the pump assembly and remove the pump mounting bolts.

· Weight : 91kg (200lb)

※ Pull out the pump assembly from housing.

When removing the pump assembly, check that all the hoses have been disconnected.

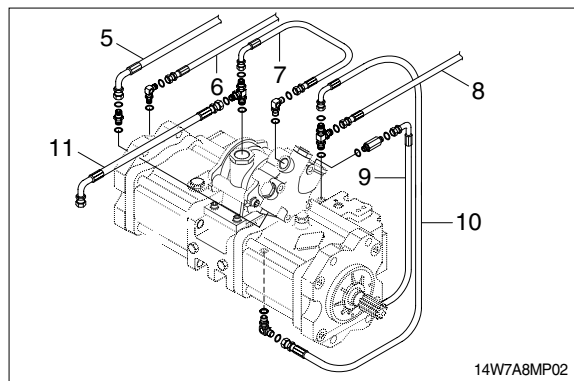
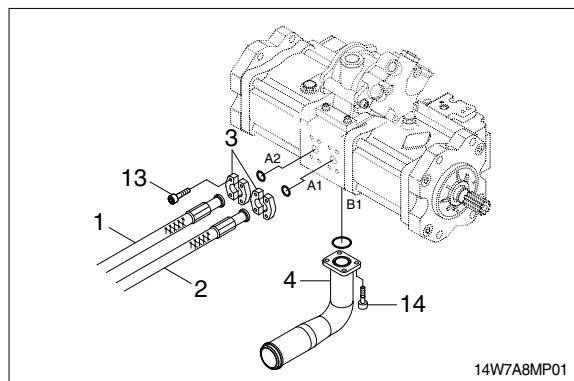

2) INSTALL

- (1) Carry out installation in the reverse order to removal.
- (2) Remove the suction strainer and clean it.
- (3) Replace return filter with new one.
- (4) Remove breather and clean it.
- (5) After adding oil to the hydraulic tank to the specified level.
- (6) Bleed the air from the hydraulic pump.
 - ① Remove the air vent plug (2EA).
 - ② Tighten plug lightly.
 - ③ Start the engine, run at low idling, and check oil come out from plug.
 - ④ Tighten plug.
- (7) Start the engine, run at low idling (3~5 minutes) to circulate the oil through the system.
- (8) Confirm the hydraulic oil level and check the hydraulic oil leak or not.

2. MAIN PUMP(1/2)

1) STRUCTURE

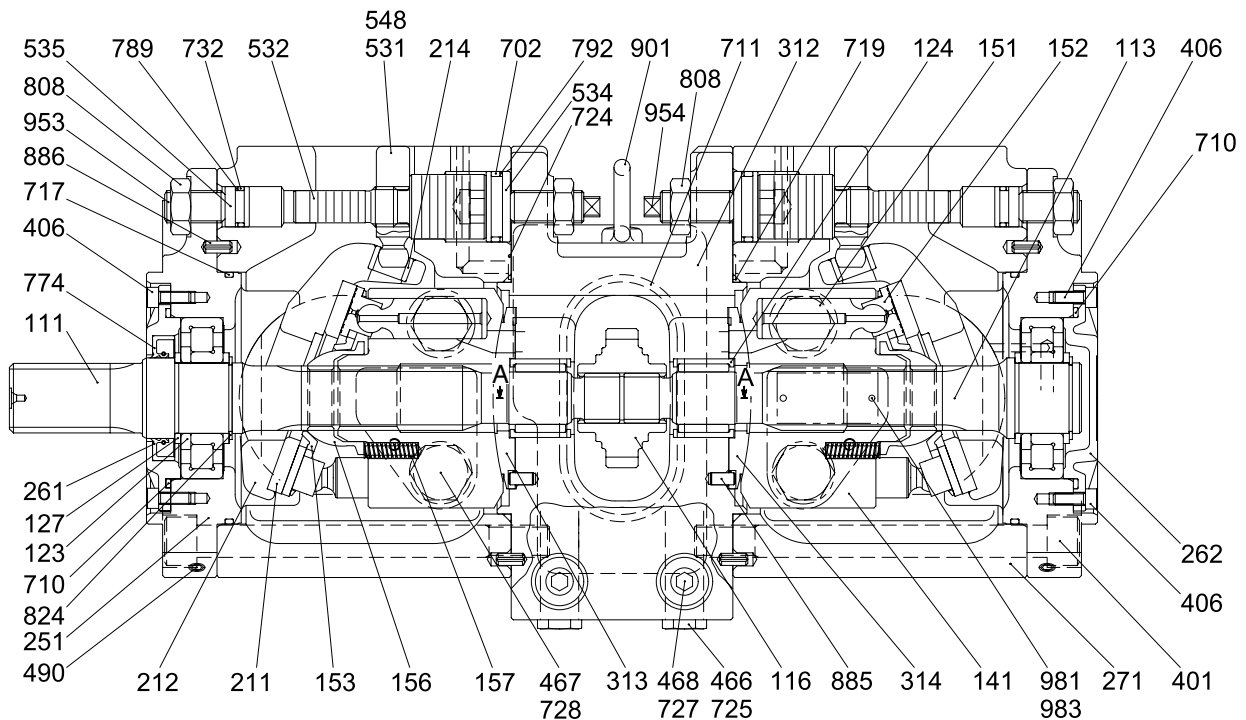

14W72SF02

111 Drive shaft (F)	312 Valve block	724 O-ring
113 Drive shaft (R)	313 Valve plate (R)	725 O-ring
116 Gear	314 Valve plate (L)	727 O-ring
123 Roller bearing	401 Hexagon socket bolt	728 O-ring
124 Needle bearing	406 Hexagon socket bolt	732 O-ring
127 Bearing spacer	466 VP Plug	774 Oil seal
141 Cylinder block	467 VP Plug	789 Back up ring
151 Piston	468 VP Plug	792 Back up ring
152 Shoe	490 Plug	808 Hexagon head nut
153 Push-plate	531 Tilting pin	824 Snap ring
156 Bushing	532 Servo piston	885 Pin
157 Cylinder spring	534 Stopper (L)	886 Spring pin
211 Shoe plate	535 Stopper (S)	901 Eye bolt
212 Swash plate	548 Pin	953 Set screw
214 Bushing	702 O-ring	954 Set screw
251 Support	710 O-ring	981 Plate
261 Seal cover (F)	711 O-ring	983 Pin
262 Seal cover (R)	717 O-ring	
271 Pump casing	719 O-ring	

MAIN PUMP(2/2)

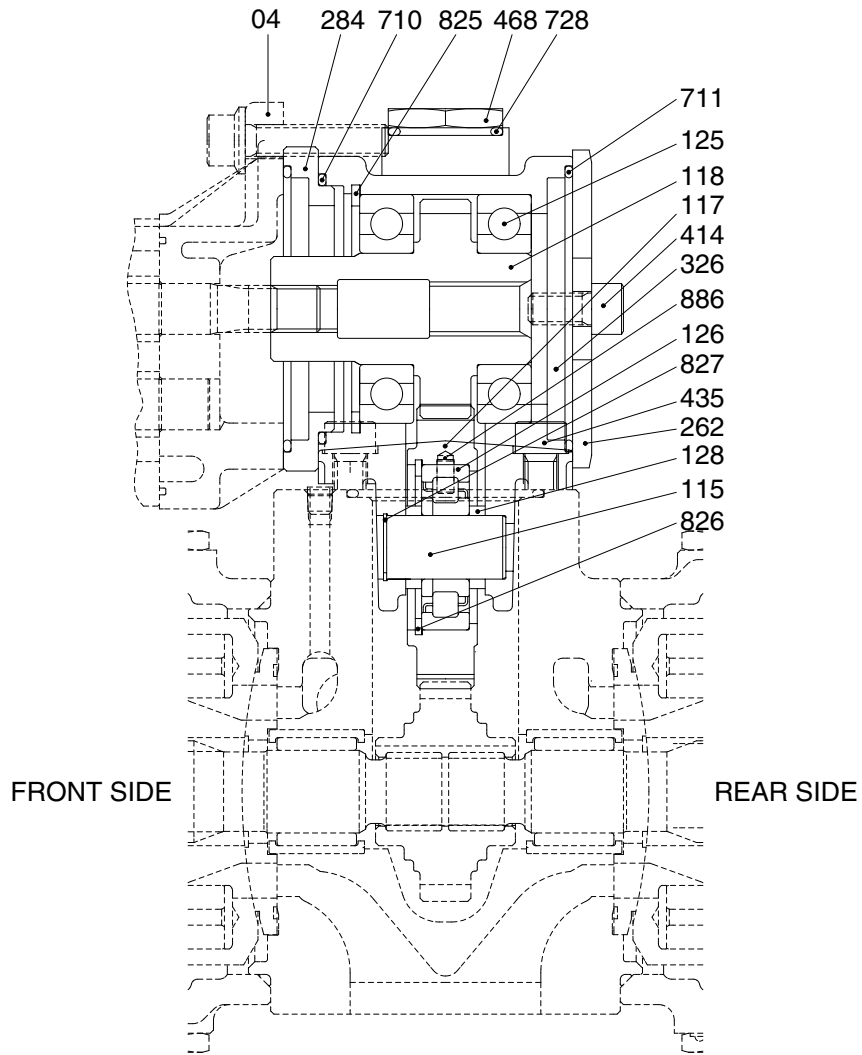



14W7A2MP03

- | | | | | | |
|-----|----------------|-----|---------------------|-----|---------------|
| 04 | Gear pump | 262 | Cover | 711 | O-ring |
| 115 | Shaft | 284 | Plate | 728 | O-ring |
| 117 | Gear No.2 | 326 | Case | 825 | Retainer ring |
| 118 | Gear No.3 | 414 | Screw | 826 | Retainer ring |
| 125 | Ball bearing | 435 | Hexagon socket bolt | 827 | Retainer ring |
| 126 | Roller bearing | 468 | Plug | 886 | Pin |
| 128 | Bearing spacer | 710 | O-ring | | |

2) TOOLS AND TIGHTENING TORQUE

(1) Tools

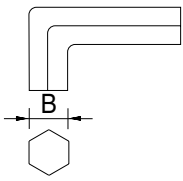
The tools necessary to disassemble/reassemble the pump are shown in the follow list.

Tool name & size		Part name			
Name	B	Hexagon socket head bolt	PT plug (PT thread)	PO plug (PF thread)	Hexagon socket head setscrew
Allen wrench 	4	M 5	BP-1/16	-	M 8
	5	M 6	BP-1/8	-	M10
	6	M 8	BP-1/4	PO-1/4	M12, M14
	8	M10	BP-3/8	PO-3/8	M16, M18
	17	M20, M22	BP-1	PO-1, 1 1/4, 1 1/2	-
Double ring spanner, socket wrench, double(Single) open end spanner 	-	Hexagon socket head bolt	Hexagon nut	VP plug (PF thread)	
	19	M12	M12	VP-1/4	
	24	M16	M16	-	
	27	M18	M18	VP-1/2	
	30	M20	M20	-	
	36	-	-	VP-3/4	
Adjustable angle wrench		Medium size, 1 set			
Screw driver		Minus type screw driver, Medium size, 2 sets			
Hammer		Plastic hammer, 1 set			
Pliers		For snap ring, TSR-160			
Steel bar		Steel bar of key material approx. 10×8×200			
Torque wrench		Capable of tightening with the specified torques			

(2) Tightening torque

Part name	Bolt size	Torque		Wrench size	
		kgf · m	lbf · ft	in	mm
Hexagon socket head bolt (Material : SCM435)	M 5	0.7	5.1	0.16	4
	M 6	1.2	8.7	0.20	5
	M 8	3.0	21.7	0.24	6
	M10	5.8	42.0	0.31	8
	M12	10.0	72.3	0.39	10
	M14	16.0	116	0.47	12
	M16	24.0	174	0.55	14
	M18	34.0	246	0.55	14
	M20	44.0	318	0.67	17
PT Plug (Material : S45C) ※ Wind a seal tape 1 1/2 to 2 turns round the plug	PT1/16	0.7	5.1	0.16	4
	PT 1/8	1.05	7.59	0.20	5
	PT 1/4	1.75	12.7	0.24	6
	PT 3/8	3.5	25.3	0.31	8
	PT 1/2	5.0	36.2	0.39	10
PF Plug (Material : S45C)	PF 1/4	3.0	21.7	0.24	6
	PF 1/2	10.0	72.3	0.39	10
	PF 3/4	15.0	109	0.55	14
	PF 1	19.0	137	0.67	17
	PF 1 1/4	27.0	195	0.67	17
	PF 1 1/2	28.0	203	0.67	17

3) DISASSEMBLY

- (1) Select place suitable to disassembling.
 - ※ Select clean place.
 - ※ Spread rubber sheet, cloth or so on on overhaul workbench top to prevent parts from being damaged.
- (2) Remove dust, rust, etc, from pump surfaces with cleaning oil or so on.
- (3) Remove drain port plug (468) and let oil out of pump casing (Front and rear pump).
- (4) Remove hexagon socket head bolts (412, 413) and remove regulator.

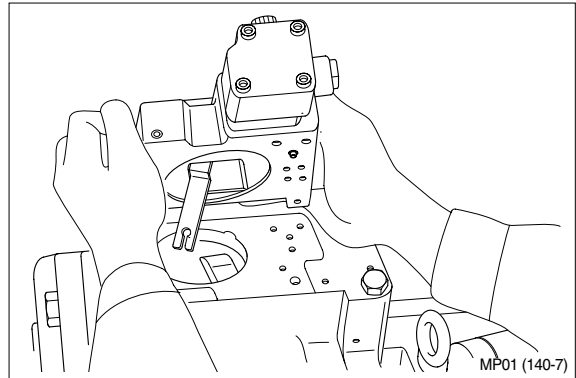

- (5) Loosen hexagon socket head bolts (401) which tighten swash plate support (251), pump casing (271) and valve block (312).
 - ※ If gear pump and so on are fitted to rear face of pump, remove them before starting this work.

- (6) Place pump horizontally on workbench with its regulator-fitting surface down and separate pump casing (271) from valve block (312).
 - ※ Before bringing this surface down, spread rubber sheet on workbench without fail to prevent this surface from being damaged.

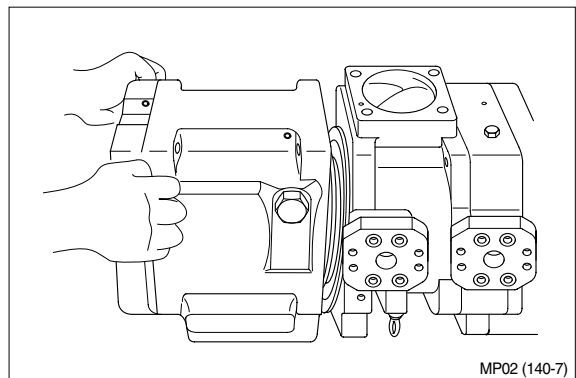

(7) Pull cylinder block (141) out of pump casing (271) straightly over drive shaft (111). Pull out also pistons (151), set plate (153), spherical bush (156) and cylinder springs (157) simultaneously.

- ※ Take care not to damage sliding surfaces of cylinder, spherical bushing, shoes, swash plate, etc.

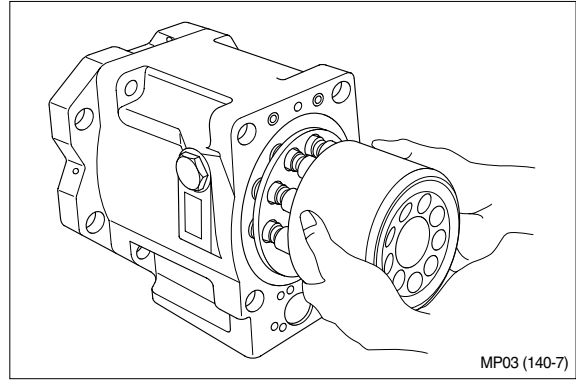

(8) Remove hexagon socket head bolts (406) and then seal cover (F, 261).

- ※ Fit bolt into pulling out tapped hole of seal cover (F), and cover can be removed easily.
- ※ Since oil seal is fitted on seal cover (F), take care not to damage it in removing cover.

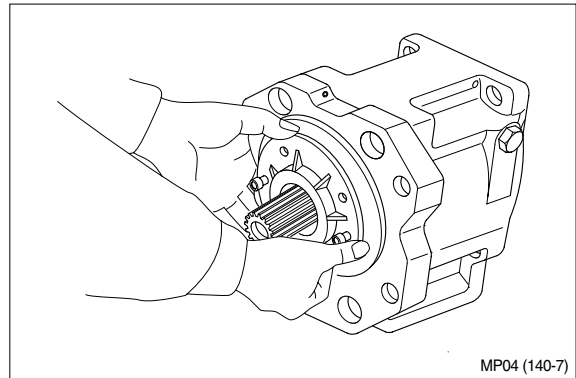

(9) Remove hexagon socket head bolts (408) and then seal cover (R, 262).

In case fitting a gear pump, first, remove gear pump.

(10) Tapping lightly fitting flange section of swash plate support (251) on its pump casing side, separate swash plate support from pump casing.

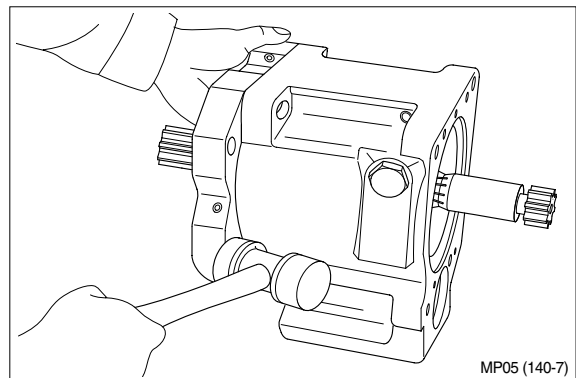

(11) Remove shoe plate (211) and swash plate (212) from pump casing (271).

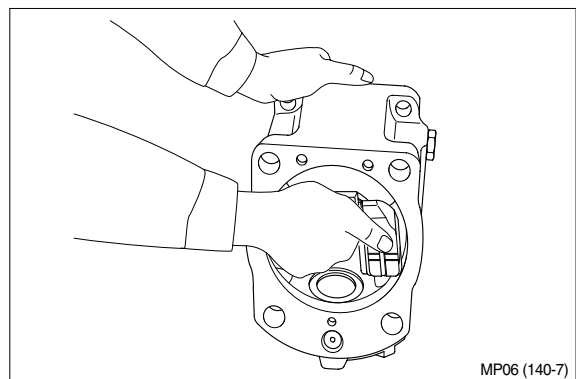

- (12) Tapping lightly shaft ends of drive shafts (111, 113) with plastic hammer, take out drive shafts from swash plate supports.

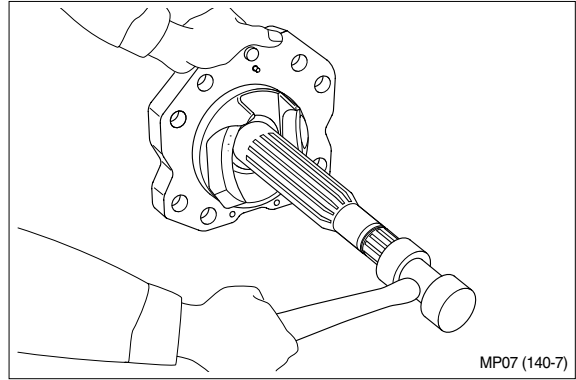

- (13) Remove valve plates (313, 314) from valve block (312).

※ These may be removed in work (6).

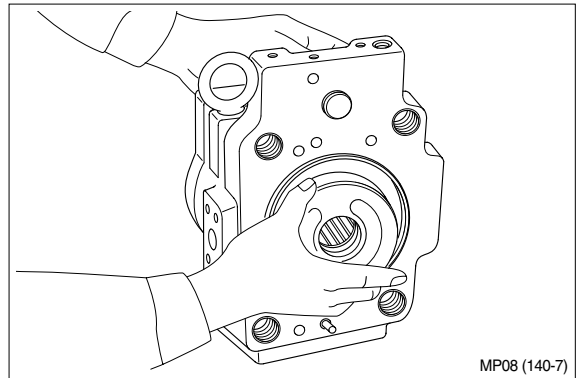

- (14) If necessary, remove stopper (L, 534), stopper (S, 535), servo piston (532) and tilting pin (531) from pump casing (271), and needle bearing (124) and splined coupling (114) from valve block (312).

- ※ In removing tilting pin, use a protector to prevent pin head from being damaged.
- ※ Since loctite is applied to fitting areas of tilting pin and servo piston, take care not to damage servo piston.
- ※ Do not remove needle bearing as far as possible, except when it is considered to be out of its life span.
- ※ Do not loosen hexagon nuts of valve block and swash plate support.
If loosened, flow setting will be changed.

4) ASSEMBLY

(1) For reassembling reverse the disassembling procedures, paying attention to the following items.

- ① Do not fail to repair the parts damaged during disassembling, and prepare replacement parts in advance.
- ② Clean each part fully with cleaning oil and dry it with compressed air.
- ③ Do not fail to apply clean working oil to sliding sections, bearings, etc. before assembling them.
- ④ In principle, replace seal parts, such as O-rings, oil seals, etc.
- ⑤ For fitting bolts, plug, etc., prepare a torque wrench or so on, and tighten them with torques shown in page 8-11, 12.
- ⑥ For the double-pump, take care not to mix up parts of the front pump with those of the rear pump.

(2) Fit swash plate support (251) to pump casing (271), tapping the former lightly with a hammer.

- ※ After servo piston, tilting pin, stopper (L) and stopper (S) are removed, fit them soon to pump casing in advance for reassembling.
- ※ In tightening servo piston and tilting pin, use a protector to prevent tilting pin head and feedback pin from being damaged. In addition, apply loctite (Medium strength) to their threaded sections.

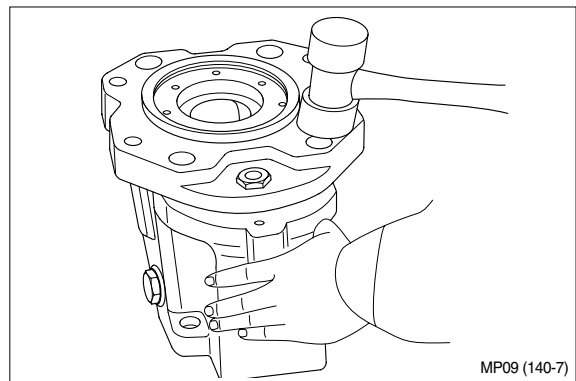

- (3) Place pump casing with its regulator fitting surface down, fit tilting bush of swash plate to tilting pin (531) and fit swash plate (212) to swash plate support (251) correctly.
- ※ Confirm with fingers of both hands that swash plate can be removed smoothly.
 - ※ Apply grease to sliding sections of swash plate and swash plate support, and drive shaft can be fitted easily.

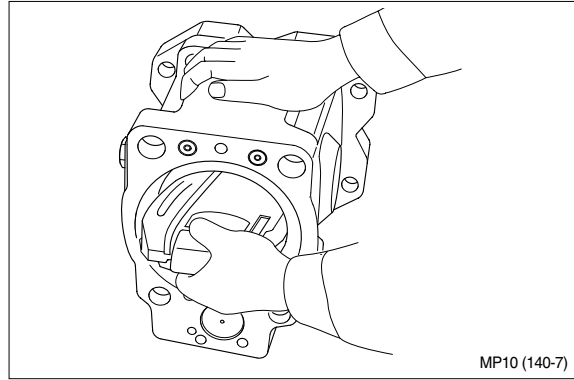

- (4) To swash plate support (251), fit drive shaft (111) set with bearing (123), bearing spacer (127) and snap ring (824).
- ※ Do not tap drive shaft with hammer or so on.
 - ※ Assemble them into support, tapping outer race of bearing lightly with plastic hammer.
- Fit them fully, using steel bar or so on.

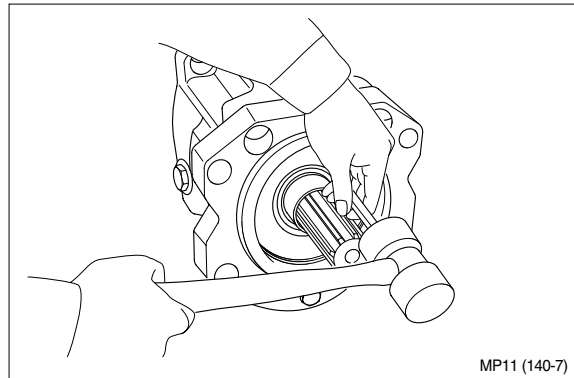

- (5) Assemble seal cover (F, 261) to pump casing (271) and fix it with hexagon socket head bolts (406).
- ※ Apply grease lightly to oil seal in seal cover (F).
 - ※ Assemble oil seal, taking full care not to damage it.
 - ※ For tandem type pump, fit rear cover (263) and seal cover (262) similarly.

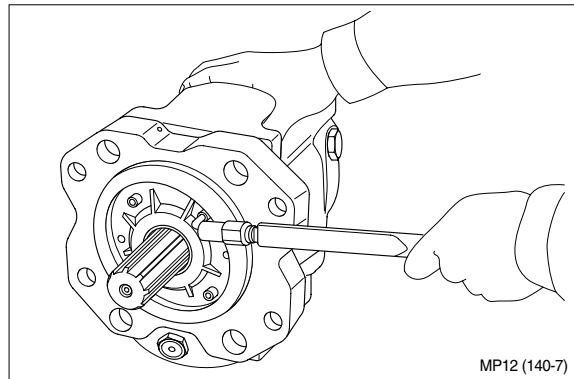

- (6) Assemble piston cylinder subassembly [cylinder block (141), piston subassembly (151, 152), set plate (153), spherical bush (156), spacer (158) and cylinder spring (157)].
- Fit spline phases of retainer and cylinder. Then, insert piston cylinder subassembly into pump casing.

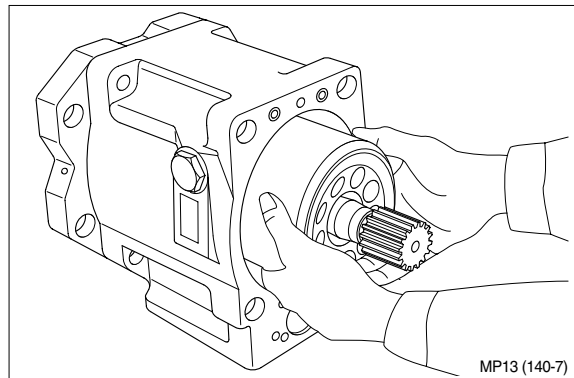

(7) Fit valve plate (313) to valve block (312), entering pin into pin hole.

- ※ Take care not to mistake suction / delivery directions of valve plate.

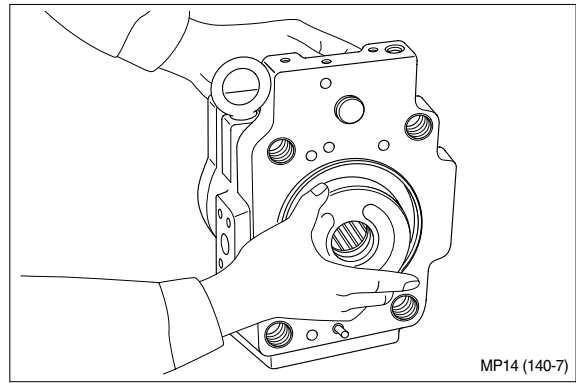

(8) Fit valve block (312) to pump casing (271) and tighten hexagon socket head bolts (401).

- ※ At first assemble this at rear pump side, and this work will be easy.
- ※ Take care not to mistake direction of valve block.
- ※ Clockwise rotation (Viewed from input shaft side) - Fit block with regulator up and with delivery flange left, viewed from front side.
- ※ Counter clockwise rotation (Viewed from input shaft side) - Fit block with delivery flange right, viewed from front side.

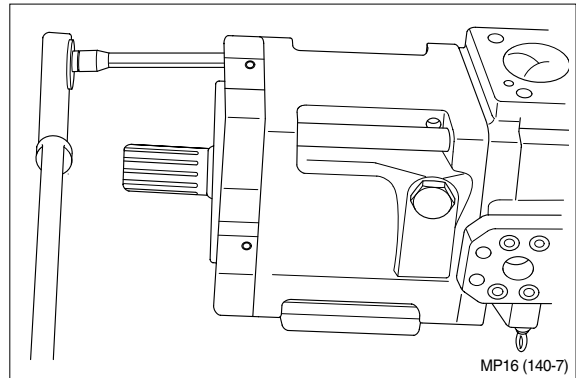

(9) Putting feedback pin of tilting pin into feedback lever of regulator, fit regulator and tighten hexagon socket head bolts (412, 413).

- ※ Take care not to mistake regulator of front pump for that of rear pump.

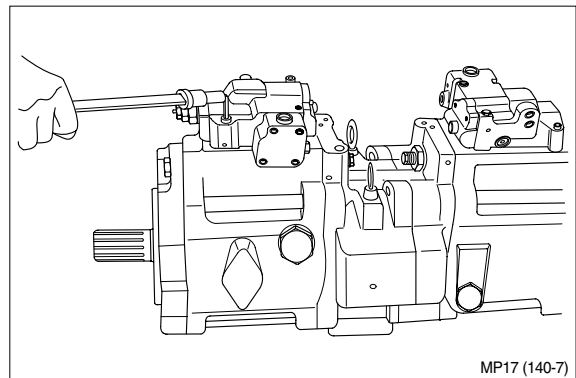

(10) Fit drain port plug (468).

This is the end of reassembling procedures.

3. REGULATOR

1) STRUCTURE(1/2)

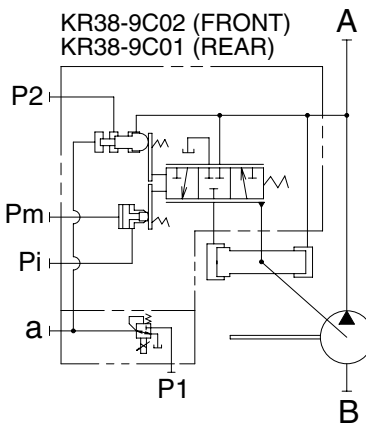
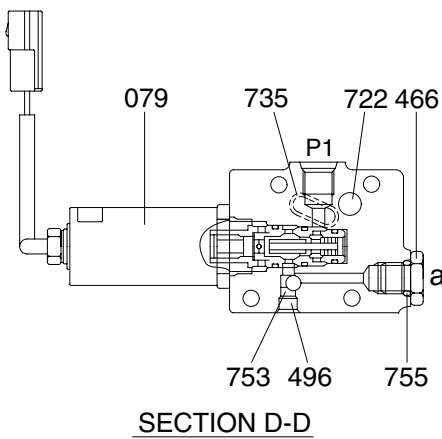
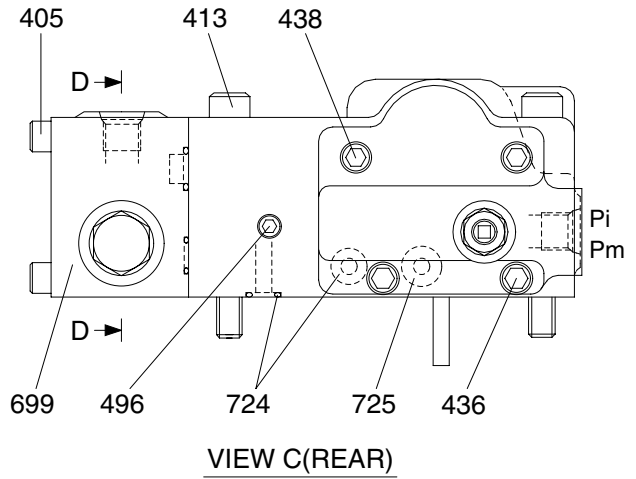
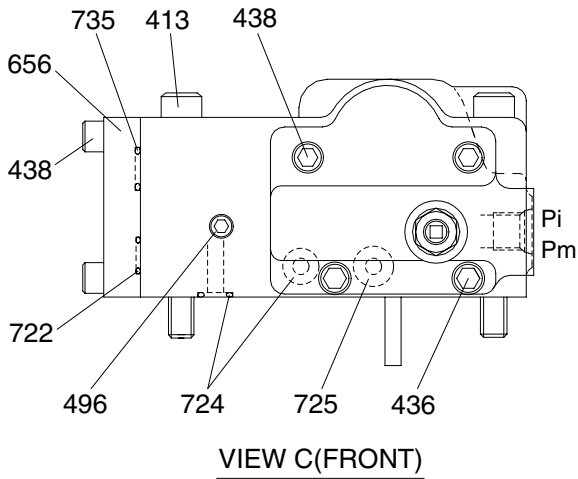
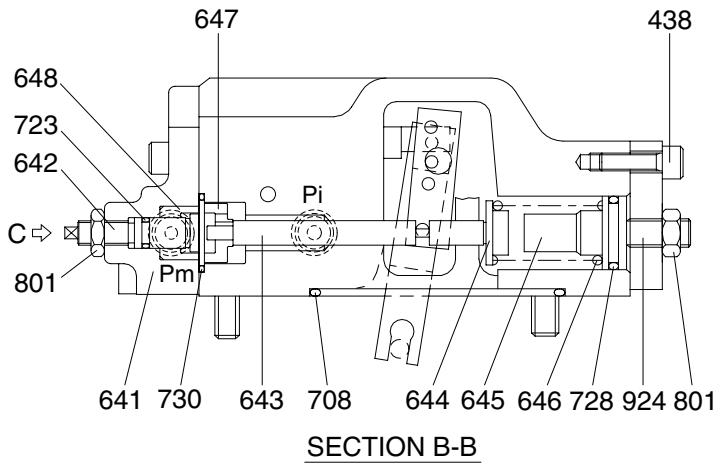
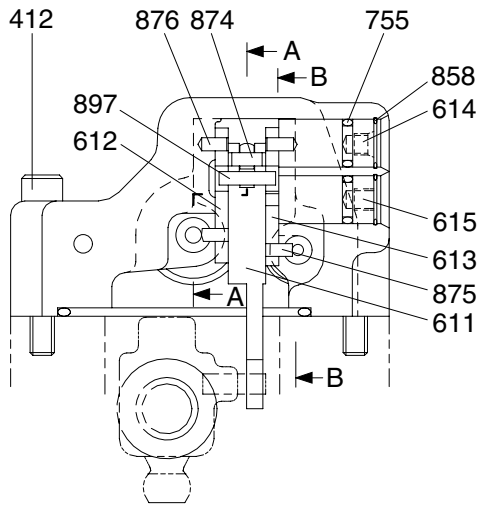

14W7A2MP04

REGULATOR(2/2)

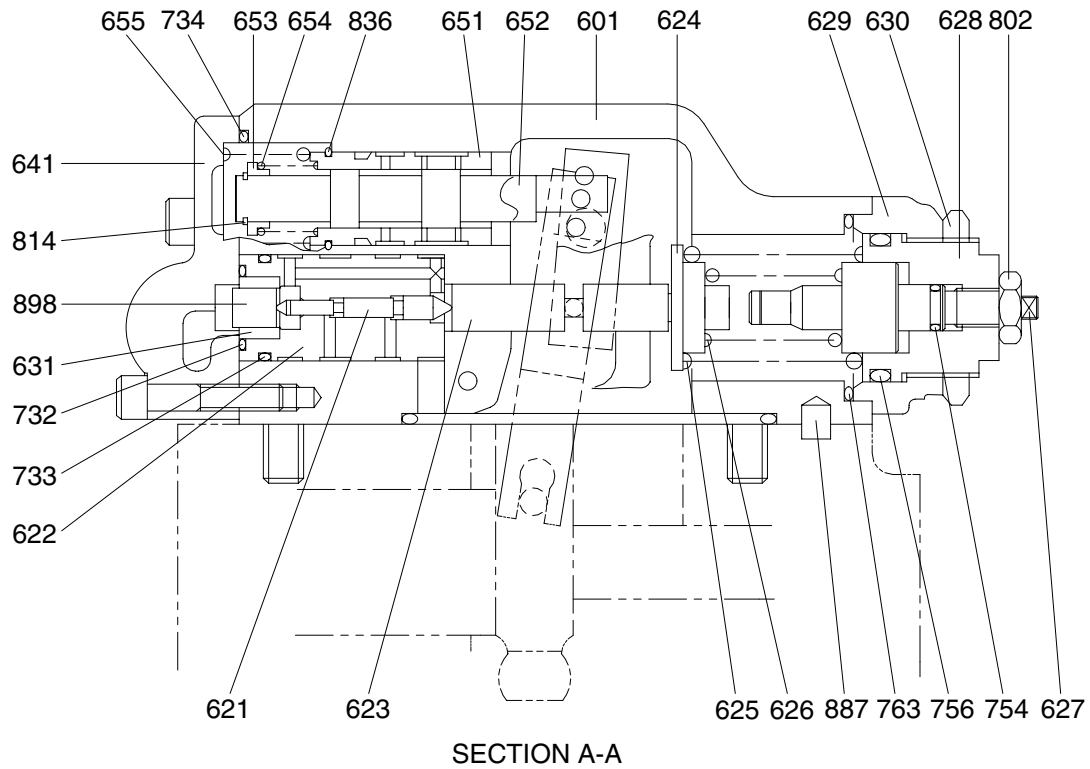



14W7A2MP05

405 Hexagon socket screw	631 Sleeve, kf	730 O-ring
412 Hexagon socket screw	641 Pilot cover	732 O-ring
413 Hexagon socket screw	642 Pilot cover (QMC)	733 O-ring
436 Hexagon socket screw	643 Pilot piston	734 O-ring
438 Hexagon socket screw	644 Spring seat (Q)	735 O-ring
466 Plug	645 Adjust stem (Q)	753 O-ring
496 Plug	646 Pilot spring	754 O-ring
601 Casing	647 Stopper	755 O-ring
611 Feed back lever	648 Piston (QMC)	756 O-ring
612 Lever (1)	651 Sleeve	763 O-ring
613 Lever (2)	652 Spool	801 Nut
614 Fulcrum plug	653 Spring seat	802 Nut
615 Adjust plug	654 Return spring	814 Snap ring
621 Compensator piston	655 Set spring	836 Snap ring
622 Piston case	656 Block cover	858 Snap ring
623 Compensator rod	699 Valve casing	874 Pin
624 Spring seat (C)	708 O-ring	875 Pin
625 Outer spring	722 O-ring	876 Pin
626 Inner spring	723 O-ring	887 Pin
627 Adjust stem (C)	724 O-ring	897 Pin
628 Adjust screw (C)	725 O-ring	898 Pin
629 Cover (C)	728 O-ring	924 Set screw
630 Lock nut		

2) TOOLS AND TIGHTENING TORQUE

(1) Tools

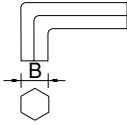
The tools necessary to disassemble/reassemble the pump are shown in the follow list.

Tool name & size		Part name			
Name	B	Hexagon socket head bolt	PT plug (PT thread)	PO plug (PF thread)	Hexagon socket head setscrew
Allen wrench 	4	M 5	BP-1/16	-	M 8
	5	M 6	BP-1/8	-	M10
	6	M 8	BP-1/4	PO-1/4	M12, M14
Double ring spanner, socket wrench, double(Single) open end spanner 	-	Hexagon head bolt	Hexagon nut	VP plug (PF thread)	
	6	M 8	M 8	-	
Adjustable angle wrench		Small size, Max 36mm			
Screw driver		Minus type screw driver, Medium size, 2 sets			
Hammer		Plastic hammer, 1 set			
Pliers		For snap ring, TSR-160			
Steel bar		4 × 100mm			
Torque wrench		Capable of tightening with the specified torques			
Pincers		-			
Bolt		M4, Length : 50mm			

(2) Tightening torque

Part name	Bolt size	Torque		Wrench size	
		kgf · m	lbf · ft	in	mm
Hexagon socket head bolt (Material : SCM435)	M 5	0.7	5.1	0.16	4
	M 6	1.2	8.7	0.20	5
	M 8	3.0	21.7	0.24	6
	M10	5.8	42.0	0.31	8
	M12	10.0	72.3	0.39	10
	M14	16.0	116	0.47	12
	M16	24.0	174	0.55	14
	M18	34.0	246	0.55	14
	M20	44.0	318	0.67	17
PT Plug (Material : S45C) ※ Wind a seal tape 1 1/2 to 2 turns round the plug	PT1/16	0.7	5.1	0.16	4
	PT 1/8	1.05	7.59	0.20	5
	PT 1/4	1.75	12.7	0.24	6
	PT 3/8	3.5	25.3	0.31	8
	PT 1/2	5.0	36.2	0.39	10
PF Plug (Material : S35C)	PF 1/4	3.0	21.7	0.24	6
	PF 1/2	10.0	72.3	0.39	10
	PF 3/4	15.0	109	0.55	14
	PF 1	19.0	137	0.67	17
	PF 1 1/4	27.0	195	0.67	17
	PF 1 1/2	28.0	203	0.67	17

3) DISASSEMBLY

Since the regulator consists of small precision finished parts, disassembly and assembly are rather complicated.

For this reason, replacement of a regulator assembly is recommended, unless there is a special reason, but in case disassembly is necessary for an unavoidable reason, read through this manual to the end before starting disassembly.

- (1) Choose a place for disassembly.
 - ※ Choose a clean place.
 - ※ Spread rubber sheet, cloth, or so on top of work-bench to prevent parts from being damaged.
- (2) Remove dust, rust, etc. from surfaces of regulator with clean oil.
- (3) Remove hexagon socket head screw (412, 413) and remove regulator main body from pump main body.
 - ※ Take care not to lose O-ring.

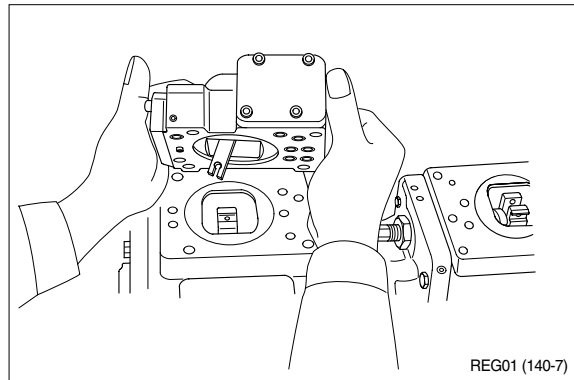

- (4) Remove hexagon socket head screw (438) and remove cover (C,629)
 - ※ Cover (C) is fitted with adjusting screw (C,QI) (628, 925), adjusting ring (C, 627), lock nut (630), hexagon nut (801) and adjusting screw (924).
Do not loosen these screws and nuts.
If they are loosened, adjusted pressure-flow setting will vary.

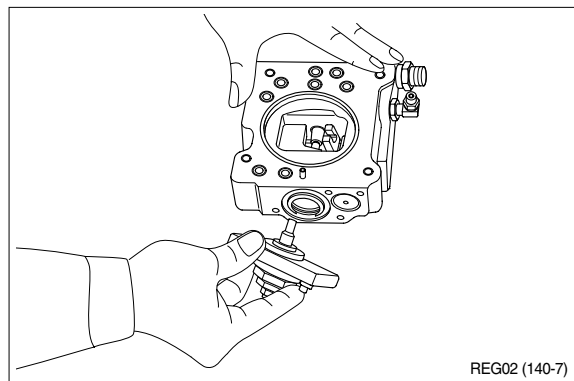

- (5) After removing cover (C, 629) subassembly, take out outer spring (625), inner spring (626) and spring seat (C, 624) from compensating section.

Then draw out adjusting ring (Q, 645), pilot spring (646) and spring seat (644) from pilot section.

- ※ Adjusting ring (Q,645) can easily be drawn out with M4 bolt.

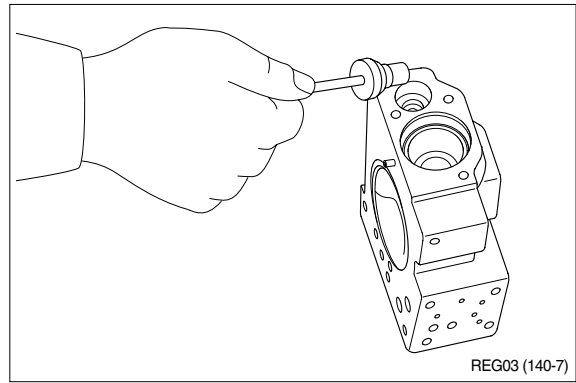

- (6) Remove hexagon socket head screws (436, 438) and remove pilot cover (641).

After removing pilot cover, take out set spring (655) from pilot section.

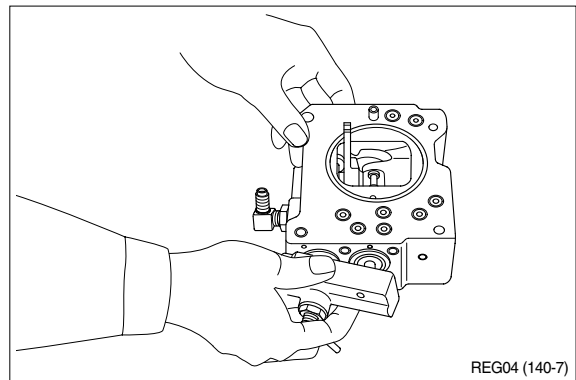

- (7) Remove snap ring (814) and take out spring seat (653), return spring (654) and sleeve (651).

- ※ Sleeve (651) is fitted with snap ring (836).
- ※ When removing snap ring (814), return spring (654) may pop out. Take care not to lose it.

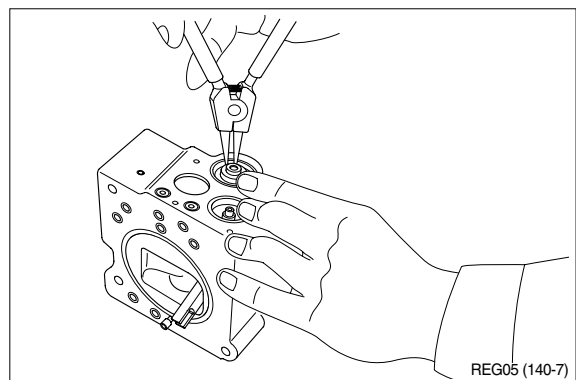

- (8) Remove locking ring (858) and take out fulcrum plug (614) and adjusting plug (615).

- ※ Fulcrum plug (614) and adjusting plug (615) can easily be taken out with M6 bolt.

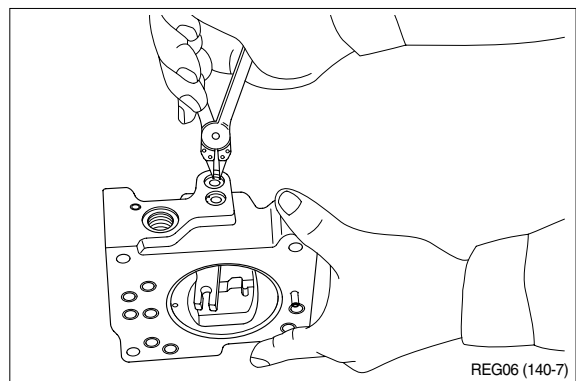

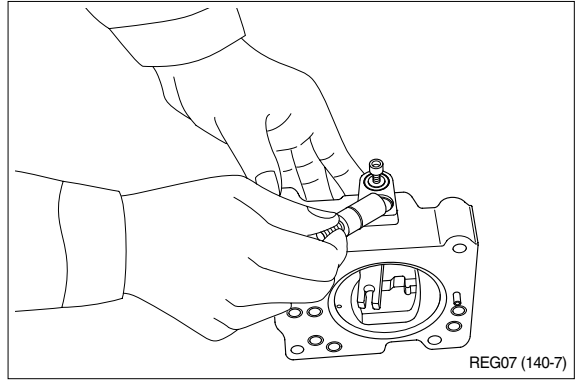

- (9) Remove lever (2, 613). Do not draw out pin (875).
※ Work will be promoted by using pincers or so on.

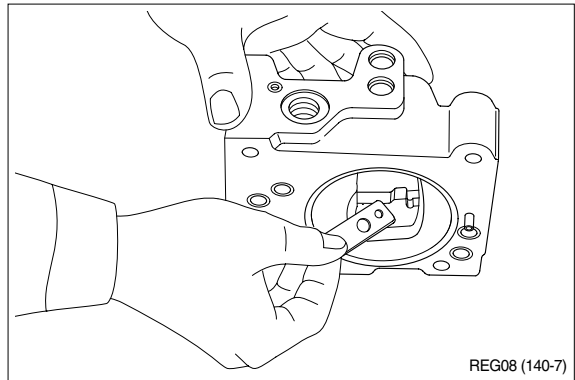

- (10) Draw out pin (874) and remove feedback lever (611).
Push out pin (874, 4mm in dia.) from above with slender steel bar so that it may not interfere with lever (1, 612).

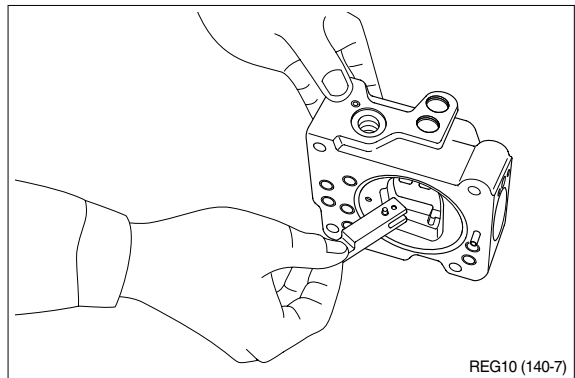
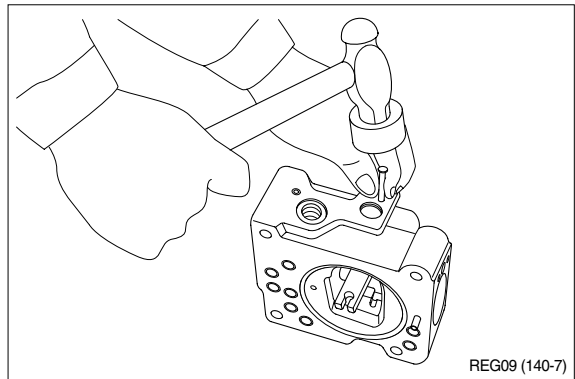

- (11) Remove lever (1, 612). Do not draw out pin (875).
- (12) Draw out pilot piston (643) and spool (652).
- (13) Draw out piston case (622), compensating piston (621) and compensating rod (623). Piston case (622) can be taken out by pushing compensating rod (623) at opposite side of piston case.

This completes disassembly.

4) ASSEMBLY

(1) For assembly, reverse disassembly procedures, but pay attention to the following items.

- ① Always repair parts that were scored at disassembly.
- ② Get replacement parts ready beforehand.
Mixing of foreign matter will cause malfunction.
Therefore, wash parts well with cleaning oil, let them dry with jet air and handle them in clean place.
- ③ Always tighten bolts, plugs, etc. to their specified torques.
- ④ Do not fail to coat sliding surfaces with clean hydraulic oil before assembly.
- ⑤ Replace seals such as O-ring with new ones as a rule.

(2) Put compensating rod (623) into compensating hole of casing (601).

(3) Put pin force-fitted in lever (1, 612) into groove of compensating rod and fit lever (1) to pin force-fitted in casing.

(4) Fit spool (652) and sleeve (651) into hole in spool of casing.

- ※ Confirm that spool and sleeve slide smoothly in casing without binding.
- ※ Pay attention to orientation of spool.

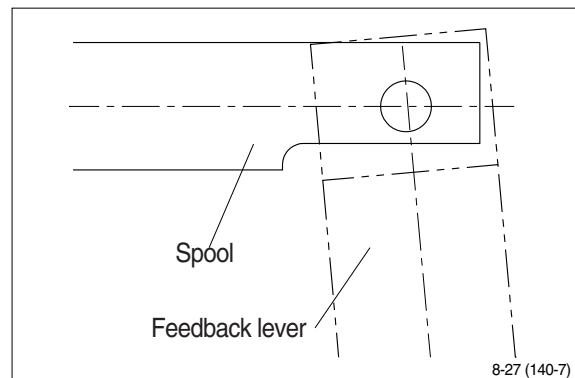

- (5) Fit feedback lever (611), matching its pin hole with pin hole in spool.
Then insert pin (874).
- ※ Insert pin in feedback lever a little to ease operation.
 - ※ Take care not to mistake direction of feedback lever.

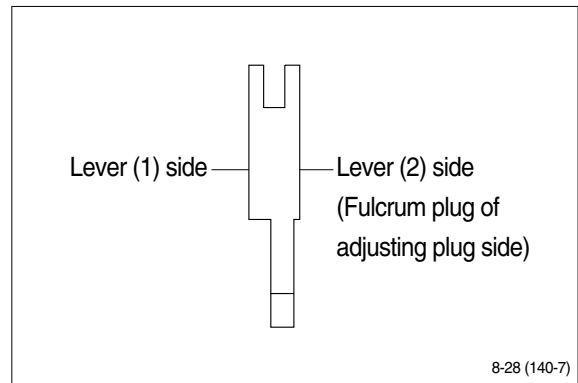

- (6) Put pilot piston (643) into pilot hole of casing.
- ※ Confirm that pilot piston slides smoothly without binding.
- (7) Put pin force-fitted in lever (2, 613) into groove of pilot piston.
Then fix lever (2).

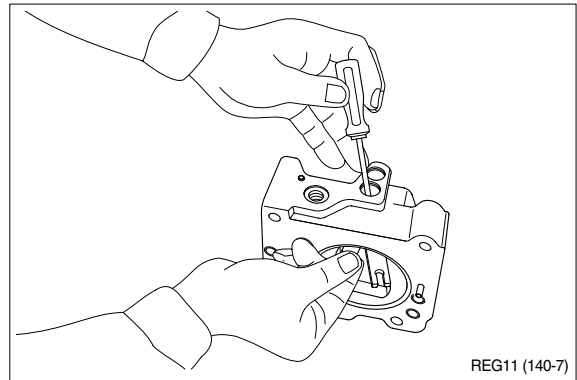

- (8) Fit fulcrum plug (614) so that pin force-fitted in fulcrum plug (614) can be put into pin hole of lever (2).
Then fix locking ring (858).
- (9) Insert adjusting plug (615) and fit locking ring.
- ※ Take care not to mistake inserting holes for fulcrum plug and adjusting plug.
- At this point in time move feedback lever to confirm that it has no large play and is free from binding.

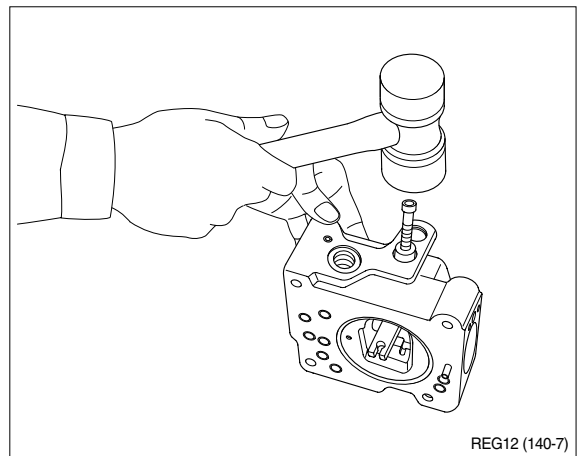

- (10) Fit return spring (654) and spring seat (653) into spool hole and attach snap ring (814).

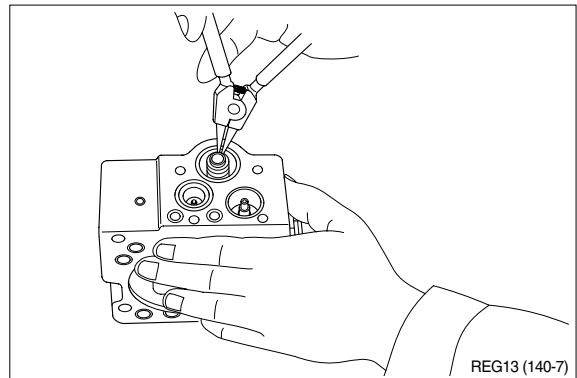

- (11) Fit set spring (655) to spool hole and put compensating piston (621) and piston case (622) into compensating hole.
Fit pilot cover (641) and tighten it with hexagonal socket head screws (436, 438).

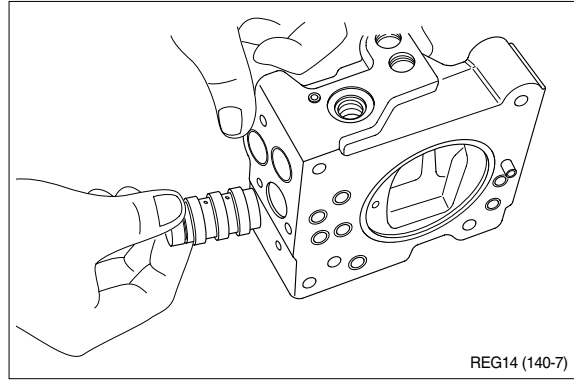

- (12) Put spring seat (644), pilot spring (646) and adjusting ring (Q, 645) into pilot hole.
Then fix spring seat (624), inner spring (626) and outer spring (625) into compensating hole.
※ When fitting spring seat, take care not to mistake direction of spring seat.

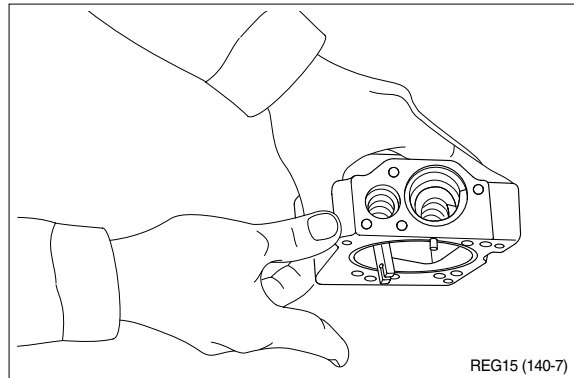

- (13) Install cover (C, 629) fitted with adjusting screws (628), adjusting ring (C, 627), lock nut (630), hexagon nut (801) and adjusting screw (924).
Then tighten them with hexagonal socket head screws (438).

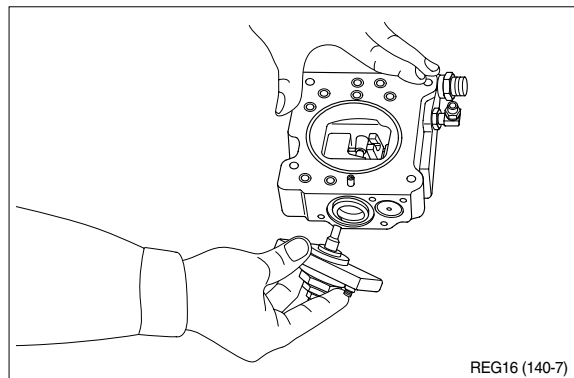

This completes assembly.