

## GROUP 13 BOOM, ARM, BUCKET, DOZER AND OUTRIGGER CYLINDERS

### 1. REMOVAL AND INSTALL

#### 1) BUCKET CYLINDER

##### (1) Removal

※ Expand the arm and bucket fully, lower the work equipment to the ground and stop the engine.

※ Operate the control levers and pedals several times to release the remaining pressure in the hydraulic piping.

▲ **Loosen the breather slowly to release the pressure inside the hydraulic tank.**

※ Escaping fluid under pressure can penetrate the skin causing serious injury. Fit blind plugs in the hoses after disconnecting them, to prevent dirt or dust from entering.

① Set block between bucket cylinder and arm.

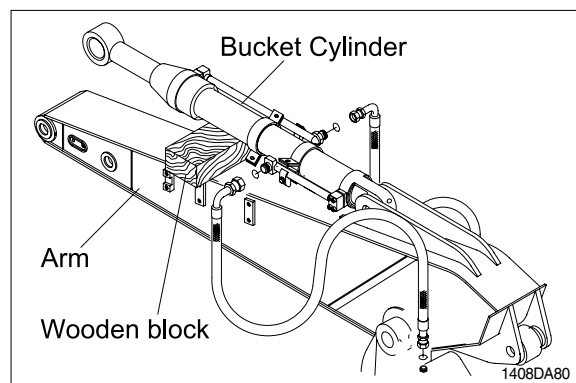

② Remove bolt (2), nut (3) and pull out pin (1).

※ Tie the rod with wire to prevent it from coming out.

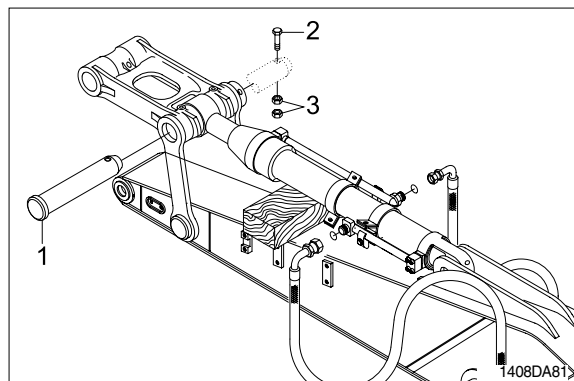

③ Disconnect bucket cylinder hoses (4) and put plugs (5) on cylinder pipe.

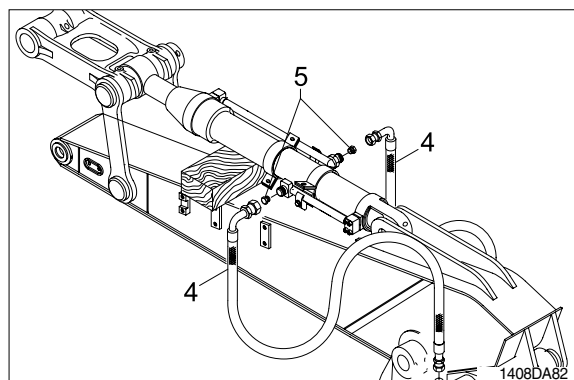

- ④ Sling bucket cylinder assembly (8) and remove bolt (6) then pull out pin (5).
- ⑤ Remove bucket cylinder assembly (8).
  - Weight : 140kg (310lb)

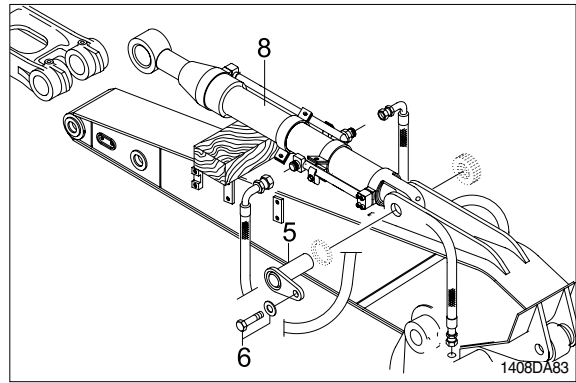

## (2) Install

- ① Carry out installation in the reverse order to removal.
- ⚠ When aligning the mounting position of the pin, do not insert your fingers in the pin hole.
  - ※ Bleed the air from the bucket cylinder.
  - ※ Confirm the hydraulic oil level and check the hydraulic oil leak or not.

## 2) ARM CYLINDER

### (1) Removal

- ※ Expand the arm and bucket fully, lower the work equipment to the ground and stop the engine.
- ※ Operate the control levers and pedals several times to release the remaining pressure in the hydraulic piping.

**▲ Loosen the breather slowly to release the pressure inside the hydraulic tank.**

- ※ Escaping fluid under pressure can penetrate the skin causing serious injury. Fit blind plugs in the hoses after disconnecting them, to prevent dirt or dust from entering.

① Set block between arm cylinder and boom.

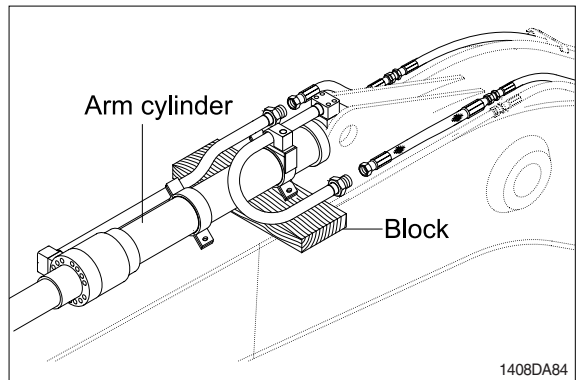

② Remove bolt (2) and pull out pin (1).

- ※ Tie the rod with wire to prevent it from coming out.

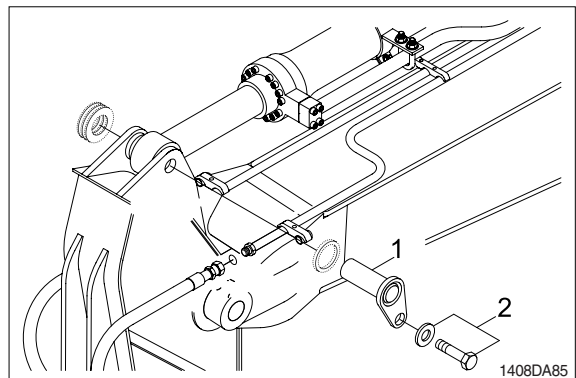

③ Disconnect arm cylinder hoses (4) and put plugs on cylinder pipe.

④ Disconnect greasing pipings (5).

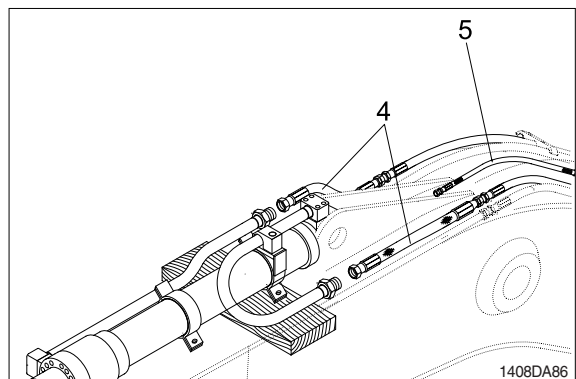

- ⑤ Sling arm cylinder assembly (8) and remove bolt (7) then pull out pin (6).
- ⑥ Remove arm cylinder assembly (8).
  - Weight : 180kg (400lb)

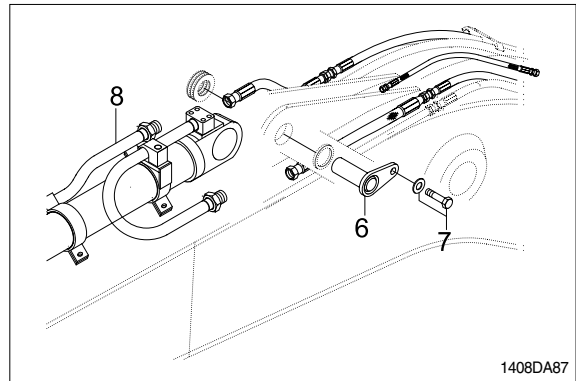

## (2) Install

- ① Carry out installation in the reverse order to removal.
- ⚠ When aligning the mounting position of the pin, do not insert your fingers in the pin hole.
  - ※ Bleed the air from the arm cylinder.
  - ※ Confirm the hydraulic oil level and check the hydraulic oil leak or not.

### 3) BOOM CYLINDER

#### (1) Removal

- ※ Expand the arm and bucket fully, lower the work equipment to the ground and stop the engine.
- ※ Operate the control levers and pedals several times to release the remaining pressure in the hydraulic piping.
- ▲ Loosen the breather slowly to release the pressure inside the hydraulic tank.
- ※ Escaping fluid under pressure can penetrate the skin causing serious injury. Fit blind plugs in the hoses after disconnecting them, to prevent dirt or dust from entering.

- ① Disconnect greasing hoses (1).
- ② Sling boom cylinder assembly.

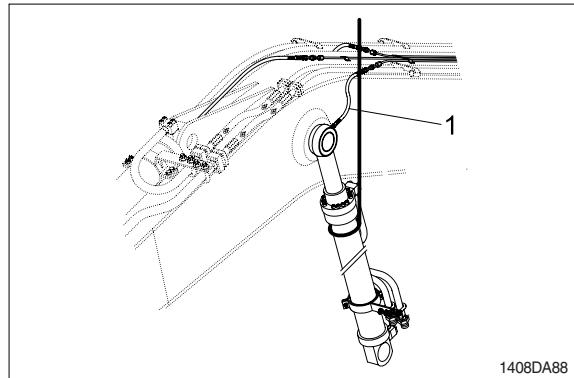
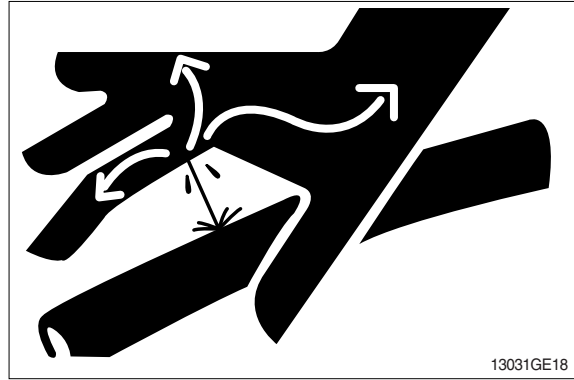

- ③ Remove bolt (4), stopper (5) and pull out pin (2).
- ※ Tie the rod with wire to prevent it from coming out.

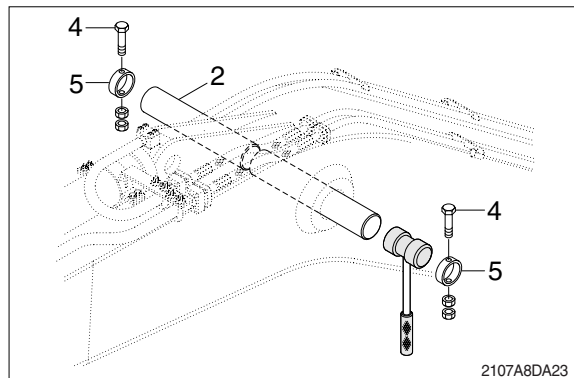

- ④ Lower the boom cylinder assembly (6) on a stand.

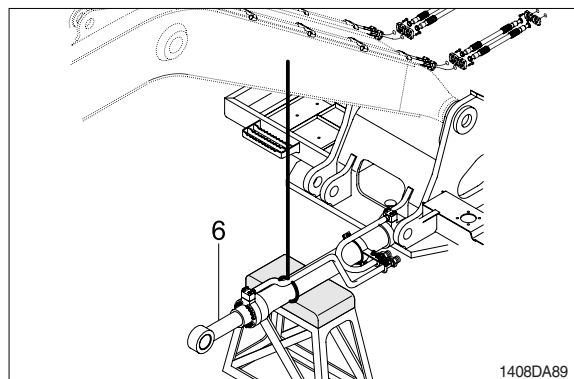

- ⑤ Disconnect boom cylinder hoses (7) and put plugs on cylinder pipe.

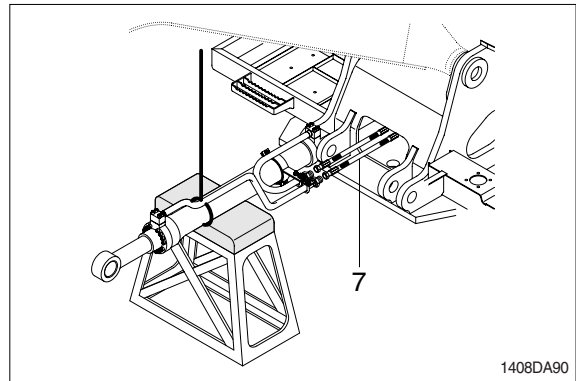

- ⑥ Remove bolt (9) and pull out pin (8).  
⑦ Remove boom cylinder assembly (6).  
· Weight : 160kg (350lb)

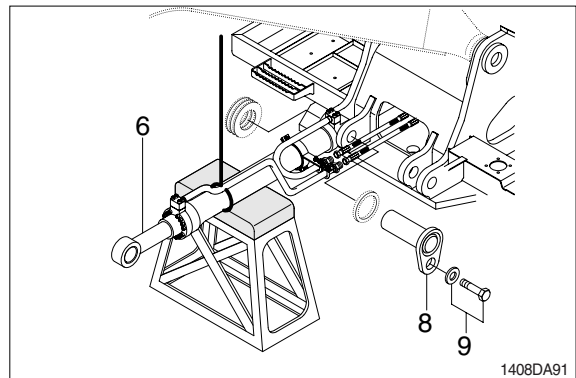

## (2) Install

- ① Carry out installation in the reverse order to removal.
- ▲ When aligning the mounting position of the pin, do not insert your fingers in the pin hole.**
- ※ Bleed the air from the boom cylinder.
  - ※ Confirmed the hydraulic oil level and check the hydraulic oil leak or not.

#### 4) DOZER CYLINDER

##### (1) Removal

- ※ Expand the arm and bucket fully, lower the work equipment to the ground and stop the engine.
- ※ Operate the control levers and pedals several times to release the remaining pressure in the hydraulic piping.
- ※ Loosen the breather slowly to release the pressure inside the hydraulic tank.

**▲ Escaping fluid under pressure can penetrate the skin causing serious injury.**

- ※ Fit blind plugs in the hoses after disconnecting them, to prevent dirt or dust from entering.

① Lower the dozer blade to the ground.

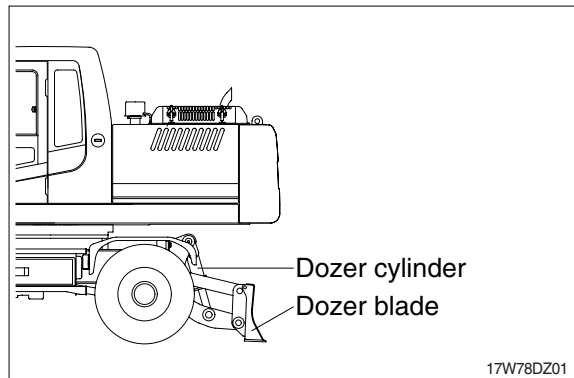

② Disconnect dozer cylinder hoses (1), and put plugs on cylinder pipe.

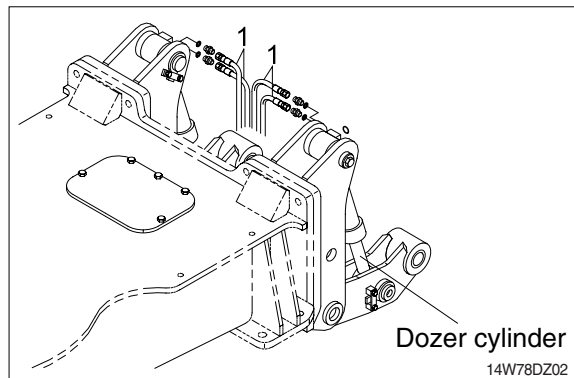

③ Sling dozer cylinder assembly.

④ Remove bolt (2) and pull out pin (3).

- ※ Tie the rod with wire to prevent it from coming out.

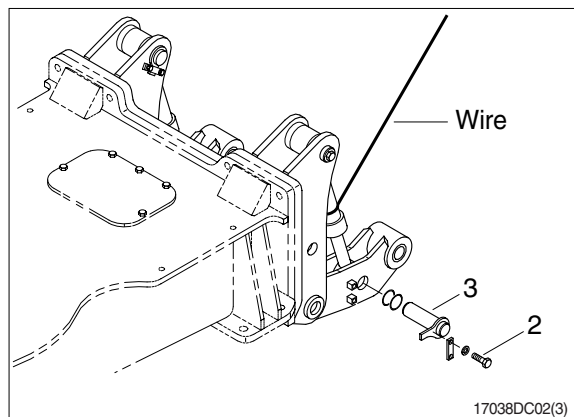

- ⑤ Lower the dozer cylinder rod side on a wooden block.

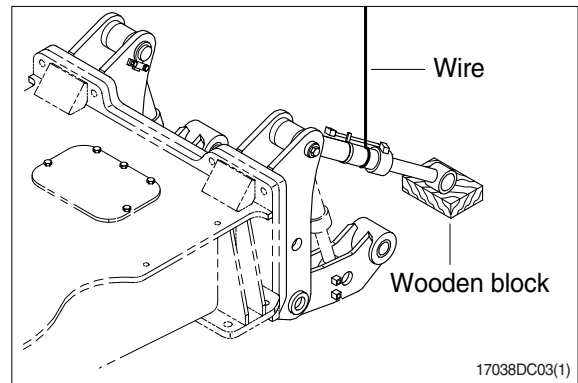

- ⑥ Loosen the bolt (4) and remove lock washer (5), hook plate (6), and spacer (7).  
⑦ Remove bolt (8) and pull out pin (9).  
⑧ Remove the dozer cylinder assy (10).  
· Weight : 55kg (120lb)

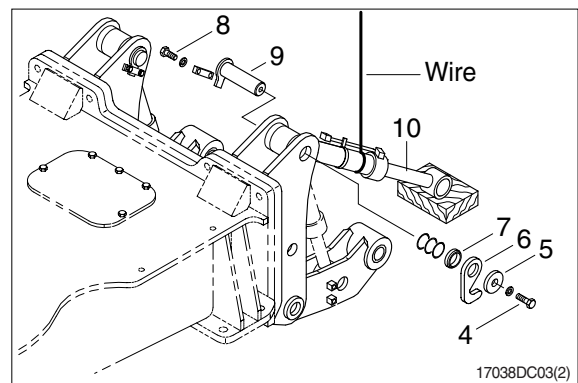

## (2) Install

- ① Carry out installation in the reverse order to removal.
- ▲ **When aligning the mounting position of the pin, do not insert your fingers in the pin hole.**
- ※ Bleed the air from the dozer cylinder.
  - ※ Confirm the hydraulic oil level and check the hydraulic oil leak or not.

## 2. DISASSEMBLY AND ASSEMBLY

### 1) STRUCTURE

#### (1) Bucket cylinder

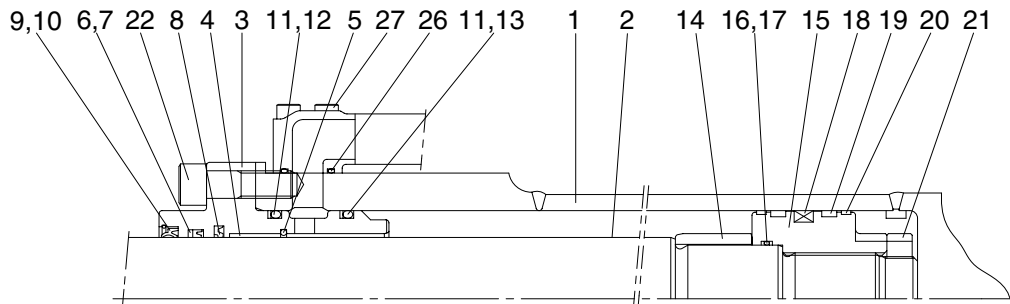

Internal detail

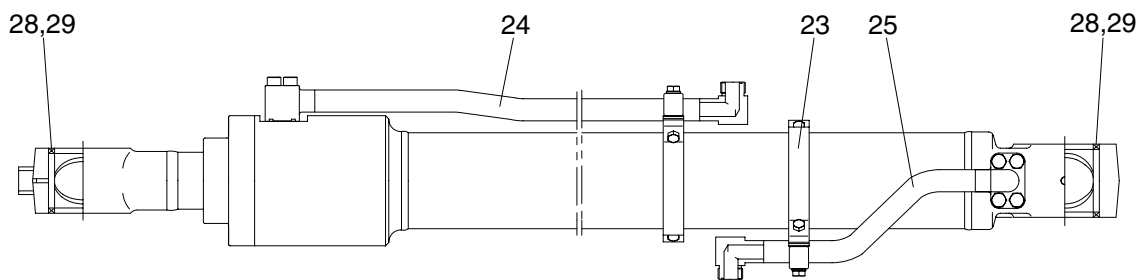

17W78CY01

1	Tube assembly	11	O-ring	21	Lock nut
2	Rod assembly	12	Back-up ring	22	Socket head bolt
3	Gland	13	Back-up ring	23	Band assembly
4	Bushing	14	Cushion ring	24	Pipe assembly(R)
5	Snap ring	15	Piston	25	Pipe assembly(B)
6	Rod seal	16	O-ring	26	O-ring
7	Back-up ring	17	Back-up ring	27	Socket head bolt
8	Buffer ring	18	Piston seal	28	Pin bushing
9	Dust wiper	19	Wear ring	29	Dust seal
10	Snap ring	20	Dust ring		

**(2) Arm cylinder**

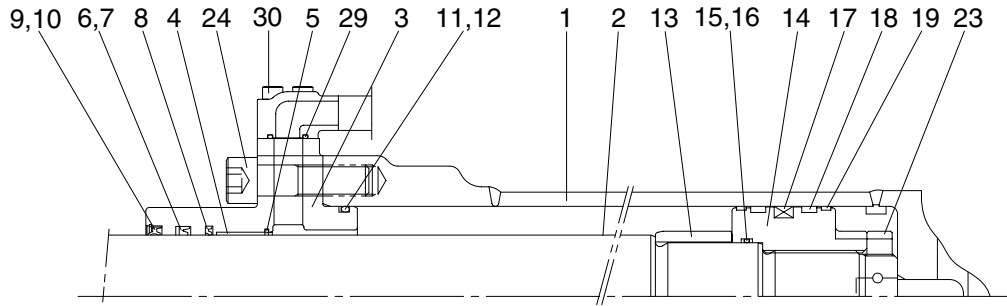

Internal detail

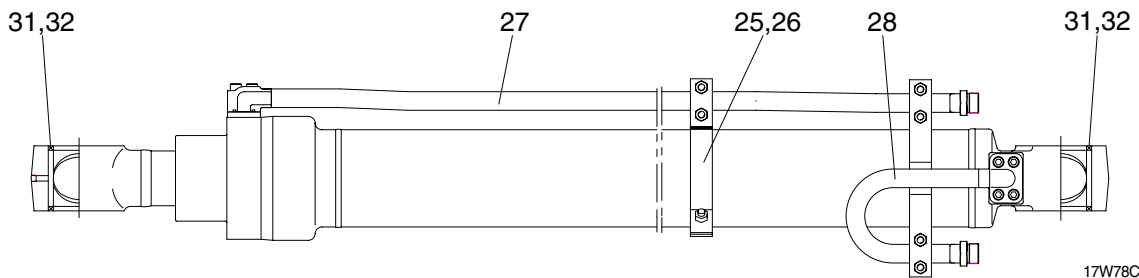

17W78CY02

- |    |               |    |              |    |                  |
|----|---------------|----|--------------|----|------------------|
| 1  | Tube assembly | 11 | O-ring       | 24 | Socket head bolt |
| 2  | Rod assembly  | 12 | Back-up ring | 25 | Band assembly(R) |
| 3  | Gland         | 13 | Cushion ring | 26 | Band assembly(B) |
| 4  | Bushing       | 14 | Piston       | 27 | Pipe assembly(R) |
| 5  | Snap ring     | 15 | O-ring       | 28 | Pipe assembly(B) |
| 6  | Rod seal      | 16 | Back-up ring | 29 | O-ring           |
| 7  | Back-up ring  | 17 | Piston seal  | 30 | Socket head bolt |
| 8  | Buffer ring   | 18 | Wear ring    | 31 | Pin bushing      |
| 9  | Dust wiper    | 19 | Dust ring    | 32 | Dust seal        |
| 10 | Snap ring     | 20 | Lock nut     |    |                  |

### (3) Boom cylinder

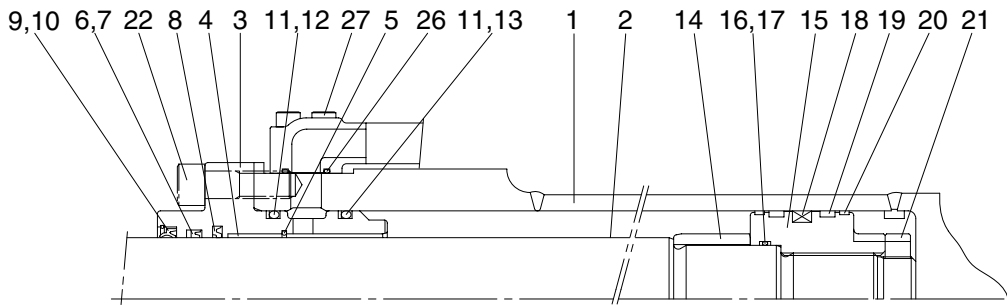

Internal detail

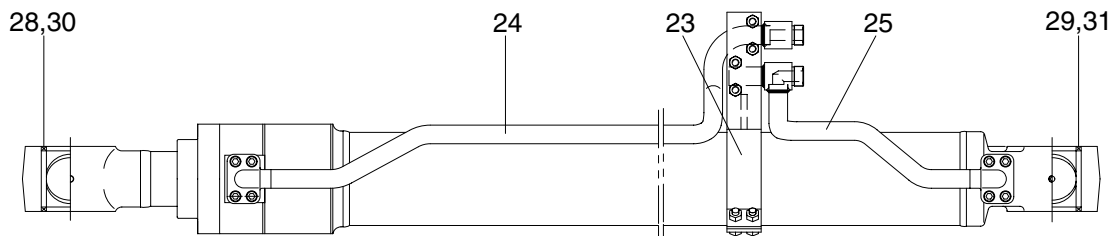

17W78CY03

- |    |               |    |              |    |                         |
|----|---------------|----|--------------|----|-------------------------|
| 1  | Tube assembly | 12 | Buck-up ring | 22 | Socket head bolt        |
| 2  | Rod assembly  | 13 | Buck-up ring | 23 | Band assembly           |
| 3  | Gland         | 14 | Cushion ring | 24 | Pipe assembly(R, LH/RH) |
| 4  | Bushing       | 15 | Piston       | 25 | Pipe assembly(B, LH/RH) |
| 5  | Snap ring     | 16 | O-ring       | 26 | O-ring                  |
| 6  | Rod seal      | 17 | Buck-up ring | 27 | Socket head bolt        |
| 7  | Buck-up ring  | 18 | Piston seal  | 28 | Pin bushing             |
| 8  | Buffer ring   | 19 | Wear ring    | 29 | Pin bushing             |
| 9  | Dust wiper    | 20 | Dust ring    | 30 | Dust seal               |
| 10 | Snap ring     | 21 | Lock nut     | 31 | Dust seal               |
| 11 | O-ring        |    |              |    |                         |

#### (4) Dozer cylinder

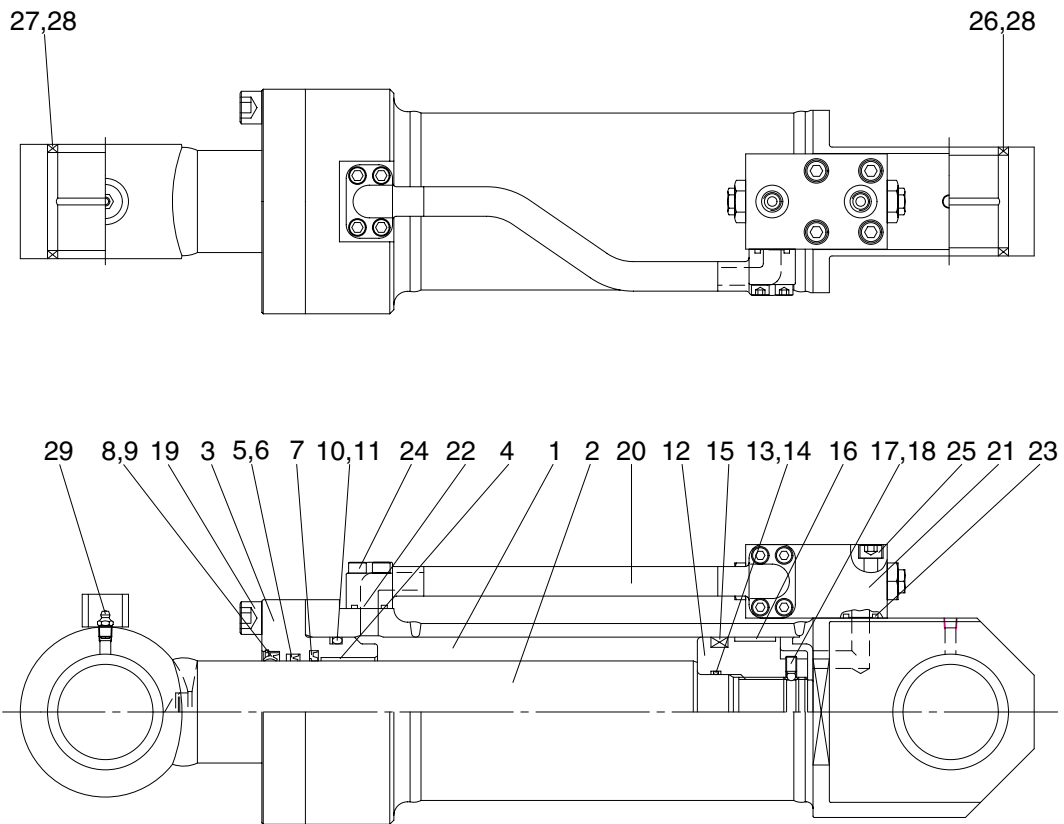

17W78CY04

1	Tube assembly	11	Back-up ring	21	Double check valve
2	Rod assembly	12	Piston	22	O-ring
3	Gland	13	O-ring	23	O-ring
4	Du bushing	14	Back-up ring	24	Socket head bolt
5	Rod seal	15	Piston seal	25	Socket head bolt
6	Back-up ring	16	Wear ring	26	Pin bushing
7	Buffer ring	17	Screw	27	Pin bushing
8	Dust wiper	18	Steel ball	28	Dust seal
9	Snap ring	19	Socket head bolt	29	Grease nipple
10	O-ring	20	Pipe assembly		

(5) Outrigger cylinder

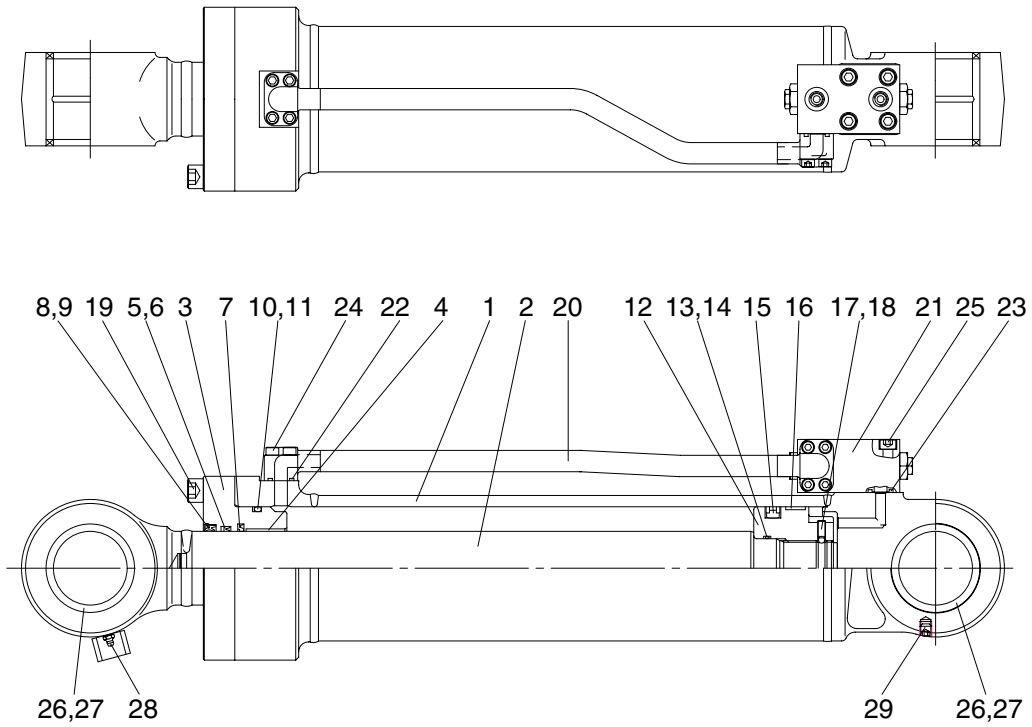

17W78CY05

- |    |               |    |                  |    |                    |
|----|---------------|----|------------------|----|--------------------|
| 1  | Tube assembly | 11 | Back-up ring     | 21 | Double check valve |
| 2  | Rod assembly  | 12 | Piston           | 22 | O-ring             |
| 3  | Gland         | 13 | O-ring           | 23 | O-ring             |
| 4  | Du bushing    | 14 | Back-up ring     | 24 | Socket head bolt   |
| 5  | Rod seal      | 15 | Piston seal      | 25 | Socket head bolt   |
| 6  | Back-up ring  | 16 | Wear ring        | 26 | Pin bushing        |
| 7  | Buffer ring   | 17 | Set screw        | 27 | Dust seal          |
| 8  | Dust wiper    | 18 | Steel ball       | 28 | Grease nipple      |
| 9  | Snap ring     | 19 | Socket head bolt | 29 | Socket head bolt   |
| 10 | O-ring        | 20 | Pipe assembly    |    |                    |

## 2) TOOLS AND TIGHTENING TORQUE

### (1) Tools

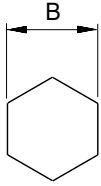
Tool name	Size		
Allen wrench	6		
	8		
	14		
	17		
Spanner	7		
	8		
(-) Driver	Small and large sizes		
Torque wrench	Capable of tightening with the specified torques		

### (2) Tightening torque

Part name	Item	Size	Torque		
			kgf · m	lbf · ft	
Socket head bolt	Bucket cylinder	22	M18	32 ± 3.0	232 ± 21.7
	Boom cylinder				
	Arm cylinder	24	M16	23 ± 2.0	166 ± 14.5
	Dozer cylinder	19	M16	23 ± 2.0	166 ± 14.5
	Outrigger cylinder				
	Bucket cylinder	27	M10	5.4 ± 0.5	39.1 ± 3.6
	Boom cylinder				
	Arm cylinder				
	Dozer cylinder	24	M8	2.7 ± 0.3	19.5 ± 2.2
	Outrigger cylinder				
	Set screw	Dozer cylinder	17	M8	2.7 ± 0.3
Outrigger cylinder					
Lock nut	Bucket cylinder	21	M55	100 ± 10.0	723 ± 72.3
	Boom cylinder	21	M55		
	Arm cylinder	23	M60		
Piston	Bucket cylinder	15	-	150 ± 15.0	1085 ± 109
	Boom cylinder				
	Arm cylinder	14			
	Dozer cylinder	12			
Outrigger cylinder					

### 3) DISASSEMBLY

#### (1) Remove cylinder head and piston rod

※ Procedures are based on the bucket cylinder.

① Hold the clevis section of the tube in a vise.

※ Use mouth pieces so as not to damage the machined surface of the cylinder tube. Do not make use of the outside piping as a locking means.

② Pull out rod assembly (2) about 200mm (7.1in). Because the rod assembly is rather heavy, finish extending it with air pressure after the oil draining operation.

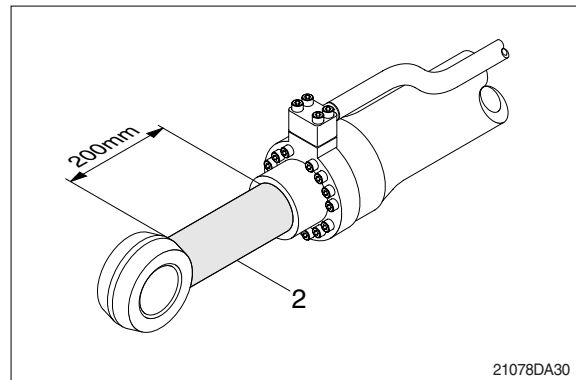

③ Loosen and remove socket bolts (22) of the gland in sequence.

※ Cover the extracted rod assembly (2) with rag to prevent it from being accidentally damaged during operation.

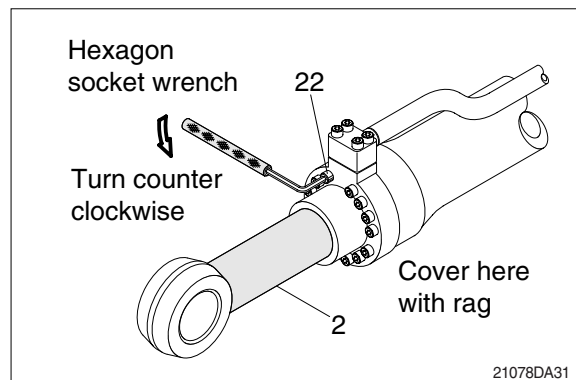

④ Draw out cylinder head and rod assembly together from tube assembly (1).

※ Since the rod assembly is heavy in this case, lift the tip of the rod assembly (2) with a crane or some means and draw it out. However, when rod assembly (2) has been drawn out to approximately two thirds of its length, lift it in its center to draw it completely.

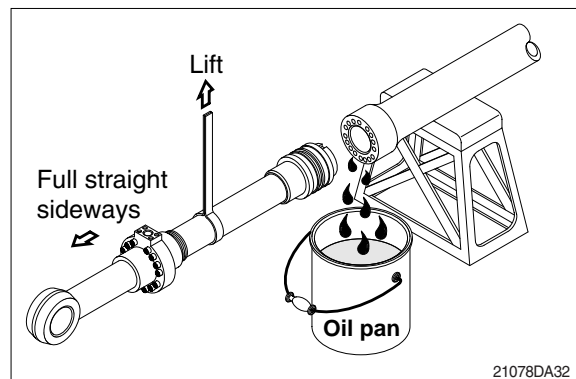

Note that the plated surface of rod assembly (2) is to be lifted. For this reason, do not use a wire sling and others that may damage it, but use a strong cloth belt or a rope.

- ⑤ Place the removed rod assembly on a wooden V-block that is set level.
- ※ Cover a V-block with soft rag.

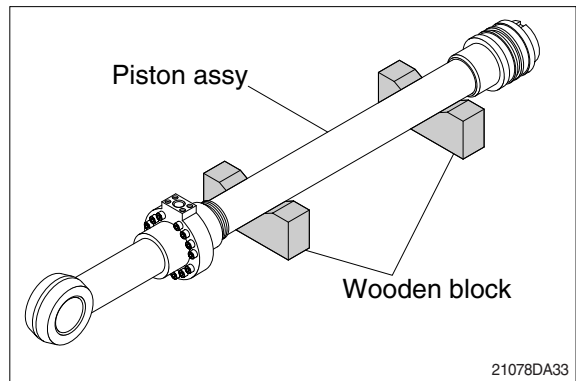

**(2) Remove piston and cylinder head**

- ① Remove lock nut (21).
- ※ Since lock nut (21) is tightened to a high torque, use a hydraulic and power wrench that utilizes a hydraulic cylinder, to remove the lock nut (21).
- ② Remove piston assembly (15), back up ring (17), and O-ring (16).

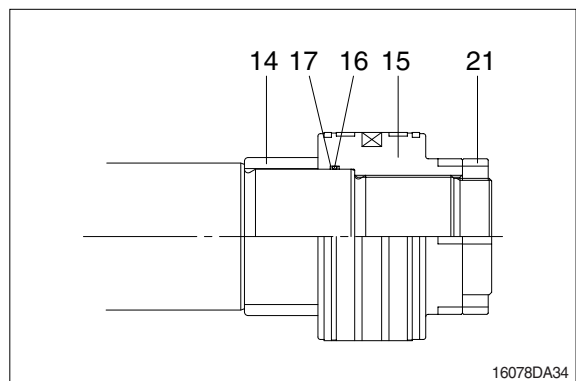

- ③ Remove the cylinder head assembly from rod assembly (2).
  - ※ If it is too heavy to move, move it by striking the flanged part of cylinder head with a plastic hammer.
  - ※ Pull it straight with cylinder head assembly lifted with a crane.
- Exercise care so as not to damage the lip of rod bushing (4) and packing (5,6,7,8,9,10) by the threads of rod assembly (2).

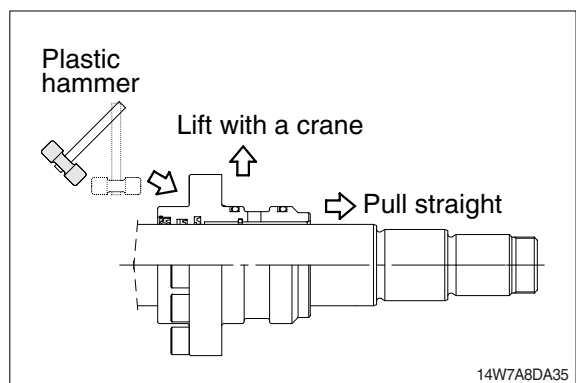

### (3) Disassemble the piston assembly

- ① Remove wear ring (19).
  - ② Remove dust ring (20) and piston seal (18).
- ※ Exercise care in this operation not to damage the grooves.

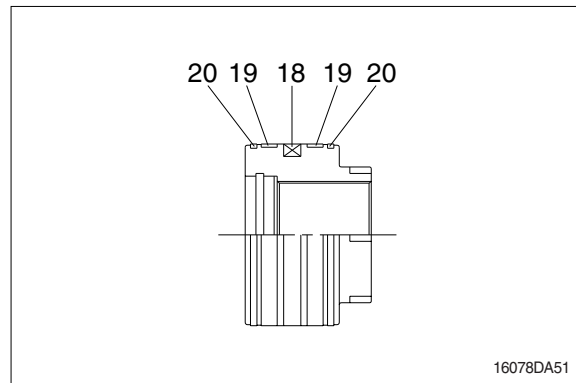

### (4) Disassemble cylinder head assembly

- ① Remove back up ring (12, 13) and O-ring (11).
  - ② Remove snap ring (10), dust wiper (9).
  - ③ Remove back up ring (7), rod seal (6), buffer ring (8) and snap ring (5).
- ※ Exercise care in this operation not to damage the grooves.
- ※ Do not remove seal and ring, if does not damaged.
- ※ Do not remove bushing (4).

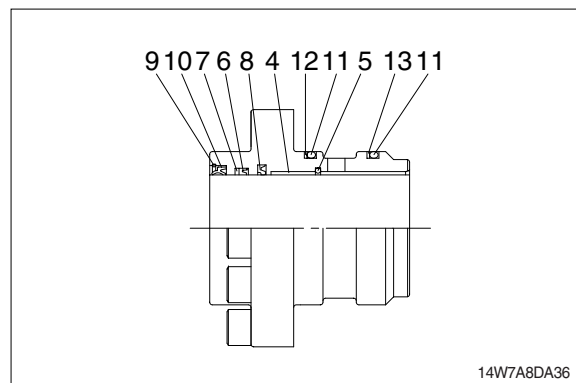

#### 4) ASSEMBLY

##### (1) Assemble cylinder head assembly

※ Check for scratches or rough surfaces if found smooth with an oil stone.

- ① Coat the inner face of gland (3) with hydraulic oil.

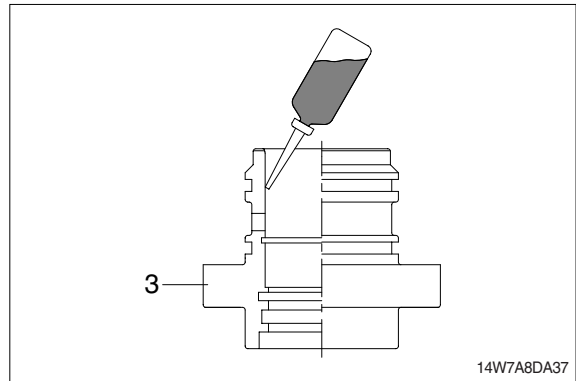

- ② Coat dust wiper (9) with grease and fit dust wiper (9) to the bottom of the hole of dust seal.

At this time, press a pad metal to the metal ring of dust seal.

- ③ Fit snap ring (10) to the stop face.

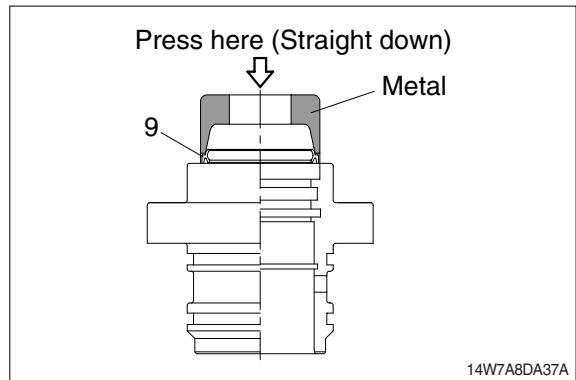

- ④ Fit back up ring (7), rod seal (6) and buffer ring (8) to corresponding grooves, in that order.

※ Coat each packing with hydraulic oil before fitting it.

※ Insert the backup ring until one side of it is inserted into groove.

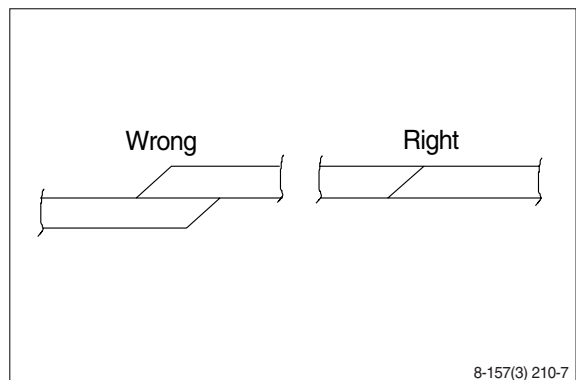

※ Rod seal (6) has its own fitting direction. Therefore, confirm it before fitting them.

※ Fitting rod seal (6) upside down may damage its lip. Therefore check the correct direction that is shown in fig.

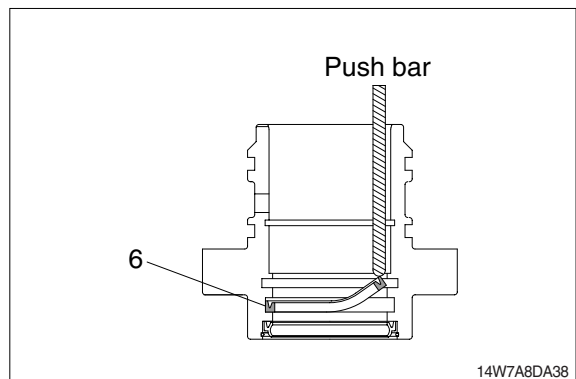

- ⑤ Fit back up ring (12, 13) to gland (3).
- ※ Put the backup ring in the warm water of 30~50°C.
- ⑥ Fit O-ring (11) to gland (3).

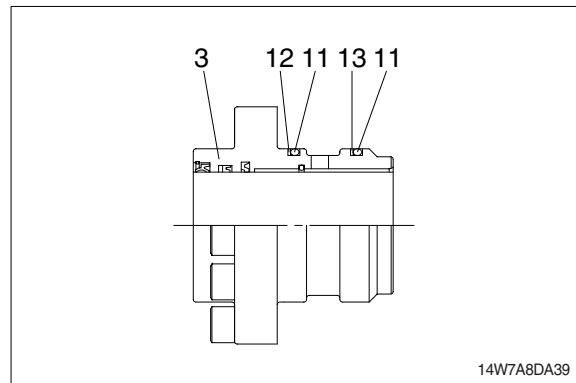

**(2) Assemble piston assembly**

- ※ Check for scratches or rough surfaces.  
If found smooth with an oil stone.
- ① Coat the outer face of piston (14) with hydraulic oil.

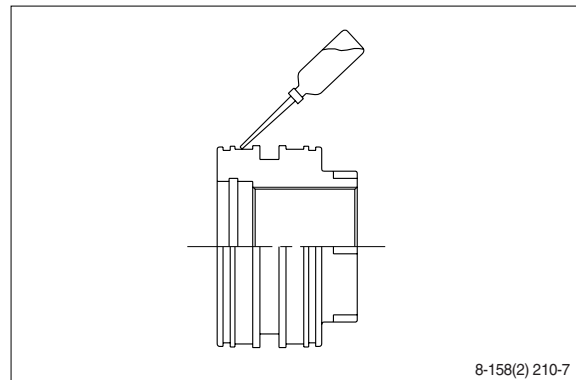

- ② Fit piston seal (18) to piston.
- ※ Put the piston seal in the warm water of 60~100°C for more than 5 minutes.
- ※ After assembling the piston seal, press its outer diameter to fit in.

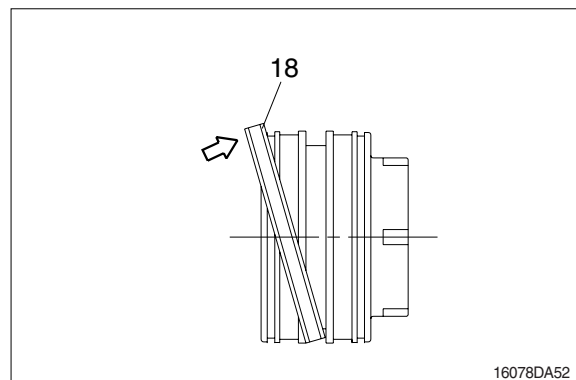

- ③ Fit wear ring (19) and dust ring (20) to piston (15).

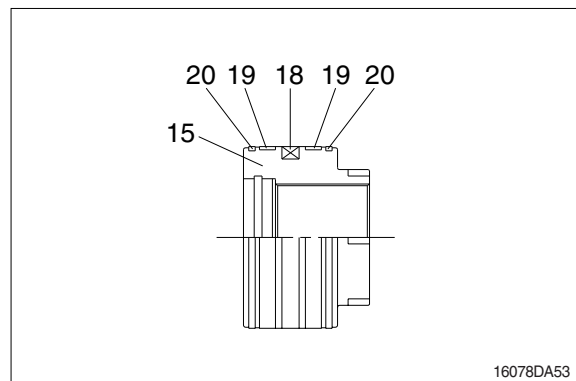

**(3) Install piston and cylinder head**

- ① Fix the rod assembly to the work bench.
- ② Apply hydraulic oil to the outer surface of rod assembly (2), the inner surface of piston and cylinder head.
- ③ Insert cylinder head assembly to rod assembly.

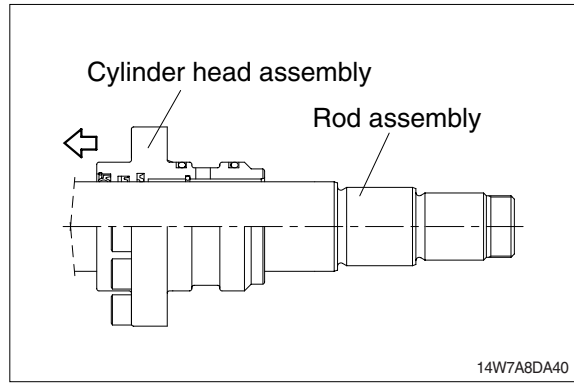

- ④ Insert cushion ring (14) to rod assembly.
- ※ Note that cushion ring (14) has a direction in which it should be fitted.

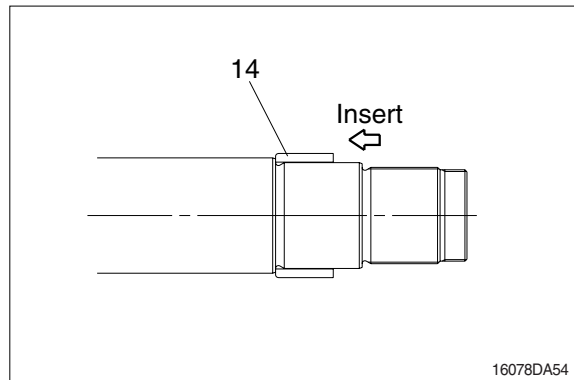

- ⑤ Fit piston assembly to rod assembly.
- Tightening torque :  $150 \pm 15.0 \text{ kgf} \cdot \text{m}$   
( $1085 \pm 109 \text{ lbf} \cdot \text{ft}$ )

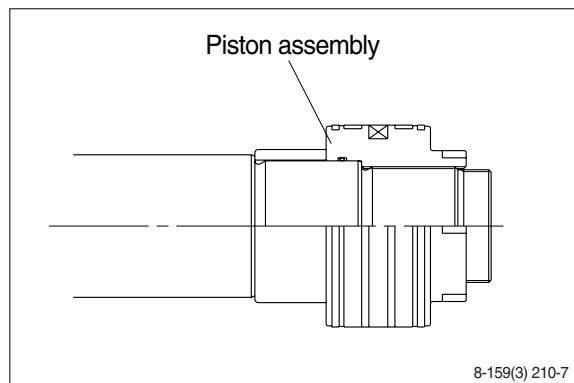

- ⑥ Fit lock nut to piston.
- Tightening torque :

Item		kgf · m	lbf · ft
Bucket	21	$100 \pm 10$	$723 \pm 72.3$
Boom	21	$100 \pm 10$	$723 \pm 72.3$
Arm	23	$100 \pm 10$	$723 \pm 72.3$

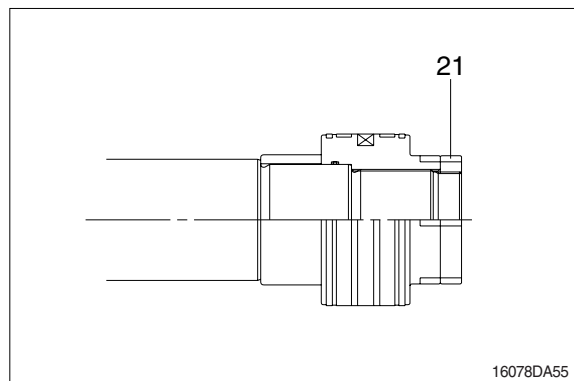

### (3) Overall assemble

- ① Place a V-block on a rigid work bench.  
Mount the tube assembly (1) on it and fix the assembly by passing a bar through the clevis pin hole to lock the assembly.
- ② Insert the rod assembly in to the tube assembly, while lifting and moving the rod assembly with a crane.
  - ※ Be careful not to damage piston seal by thread of tube assembly.
- ③ Match the bolt holes in the cylinder head flange to the tapped holes in the tube assembly and tighten socket bolts to a specified torque.
  - ※ Refer to the table of tightening torque.

