

GROUP 4 MECHATRONICS SYSTEM

1. ALL ACTUATORS SPEED ARE SLOW

- ※ Boom, Arm, Bucket, Swing and travel speed are slow, but engine speed is good.
- ※ Spec : M-mode 2000±50rpm H-mode 1900±50rpm S-mode 1800±50rpm
- ※ Before carrying out below procedure, check all the related connectors are properly inserted.

1) INSPECTION PROCEDURE

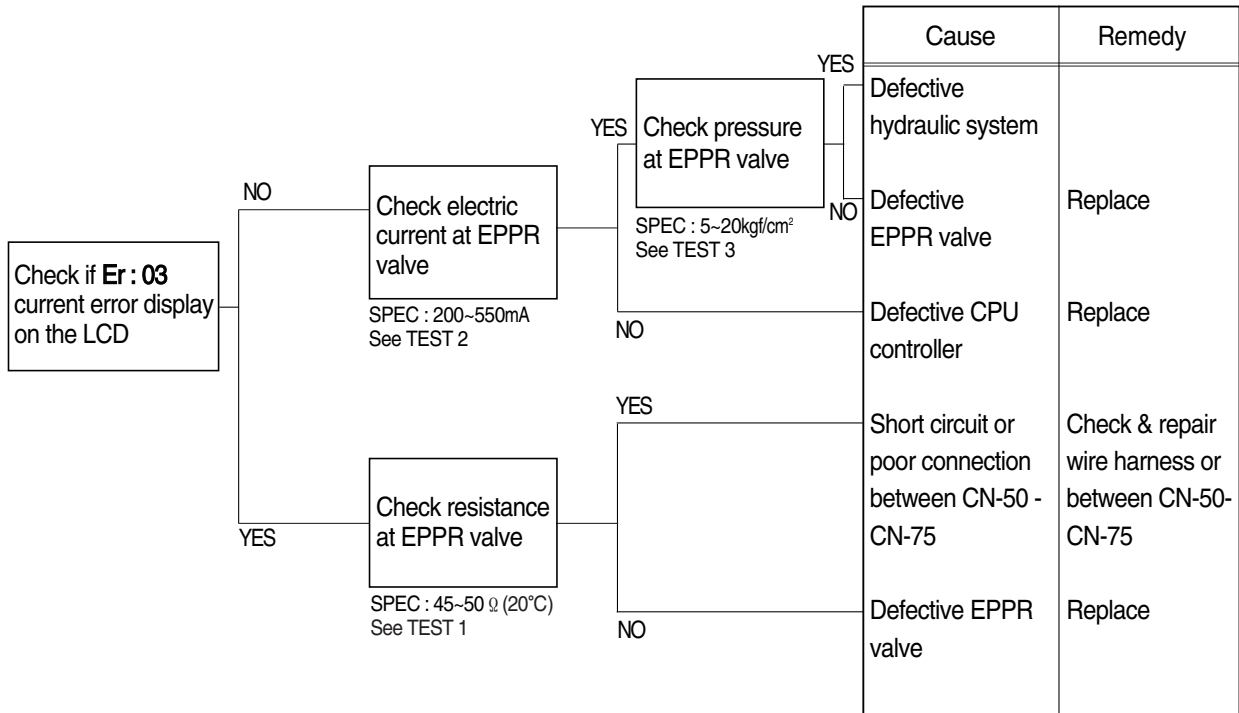

Wiring diagram

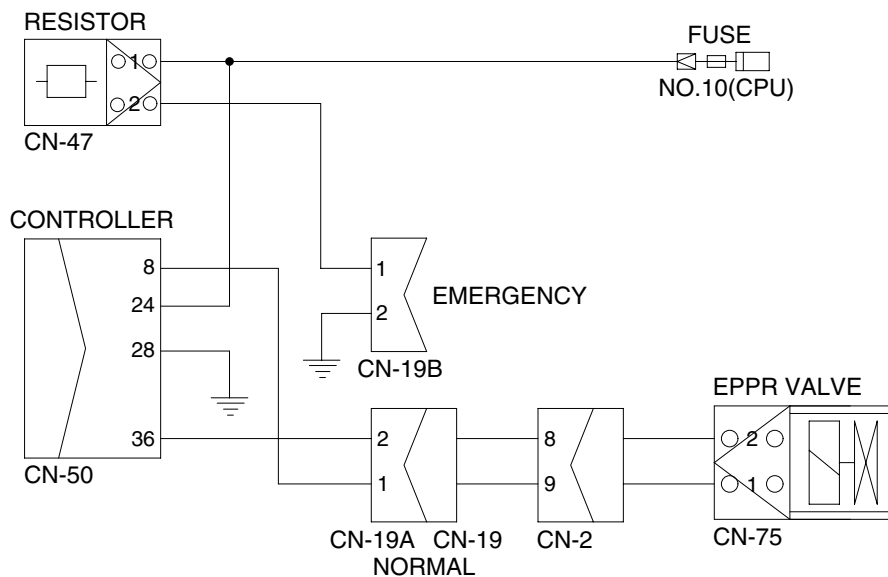

14W7A6MS01

2) TEST PROCEDURE

(1) **Test 1** : Check resistance at connector CN-75.

- ① Starting key OFF.
- ② Disconnect connector CN-75 from EPPR valve at main hydraulic pump.
- ③ Check resistance between 2 lines as figure.

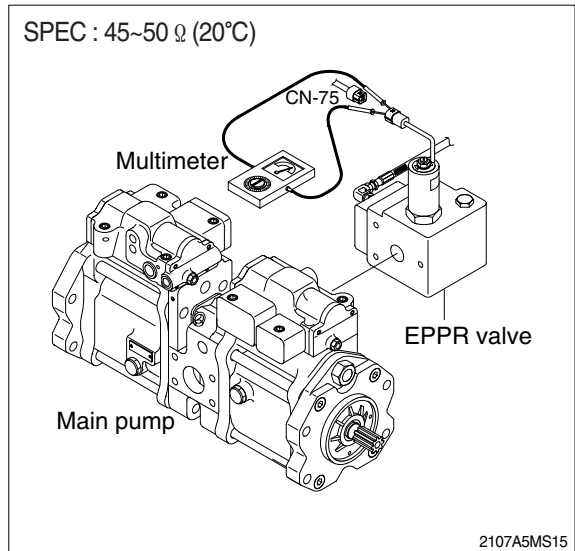

(2) **Test 2** : Check electric current at EPPR valve.

- ① Install multimeter as figure.
- ② Start engine.
- ③ Set the accel dial at "10"(MAX)
- ④ Set S-mode and cancel auto decel mode.
- ⑤ If tachometer show approx 1800 \pm 50rpm, check electric current.

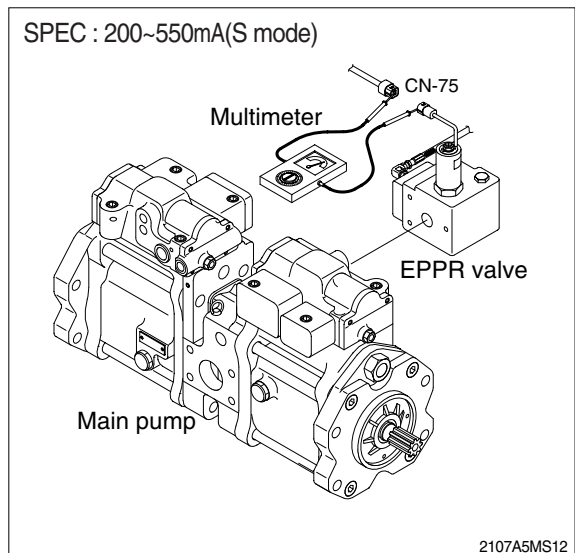

(3) **Test 3** : Check pressure at EPPR valve.

- ① Remove plug and connect pressure gauge as figure.
 - Gauge capacity : 0 to 40~50kgf/cm²
(0 to 570~710psi)
- ② Start engine.
- ③ Set the accel dial at "10"(Max).
- ④ Set S-mode and cancel auto decel mode.
- ⑤ If tachometer show approx 1800 \pm 50rpm, check pressure.
- ⑥ If pressure is not correct, adjust it.
- ⑦ After adjust, test the machine.

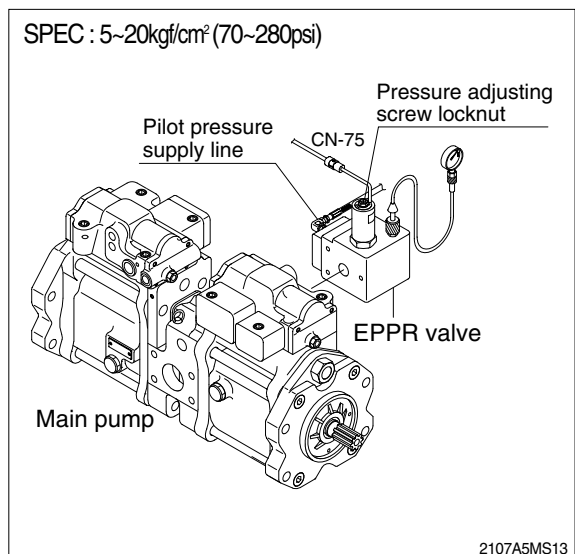

2. ENGINE STALL

※ Before carrying out below procedure, check all the related connectors are properly inserted.

1) INSPECTION PROCEDURE

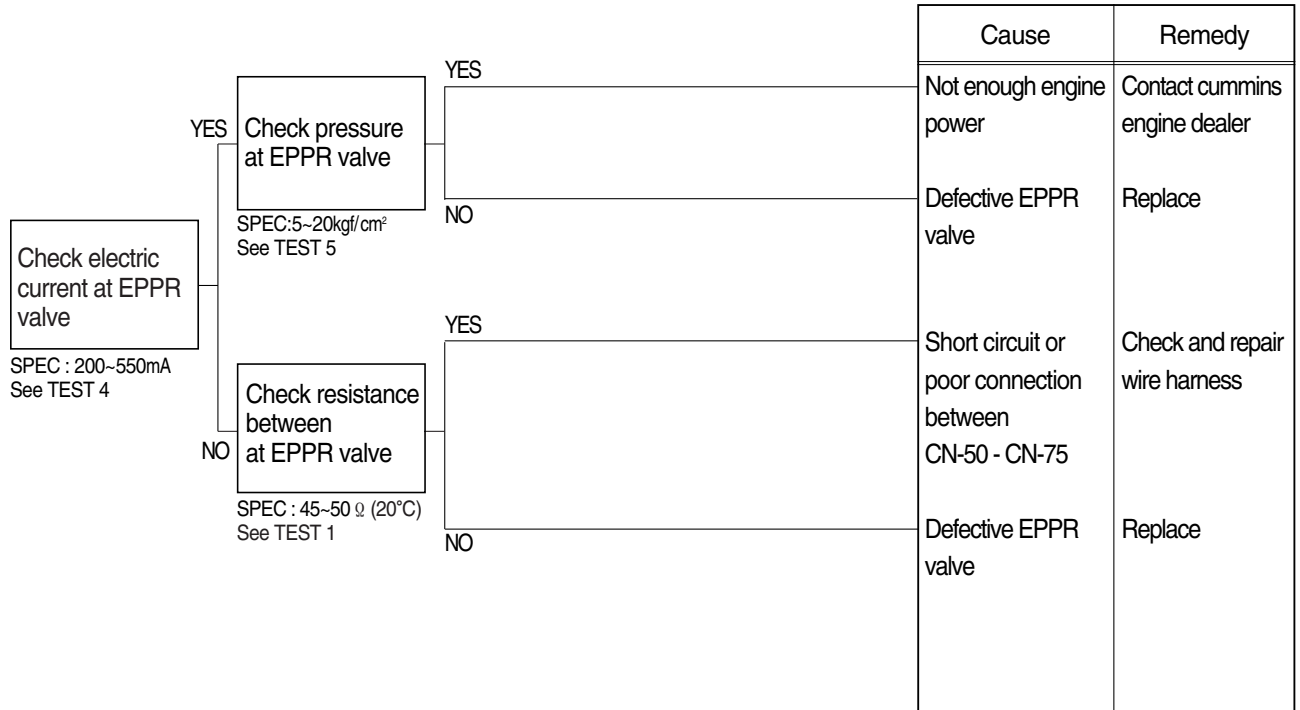

Wiring diagram

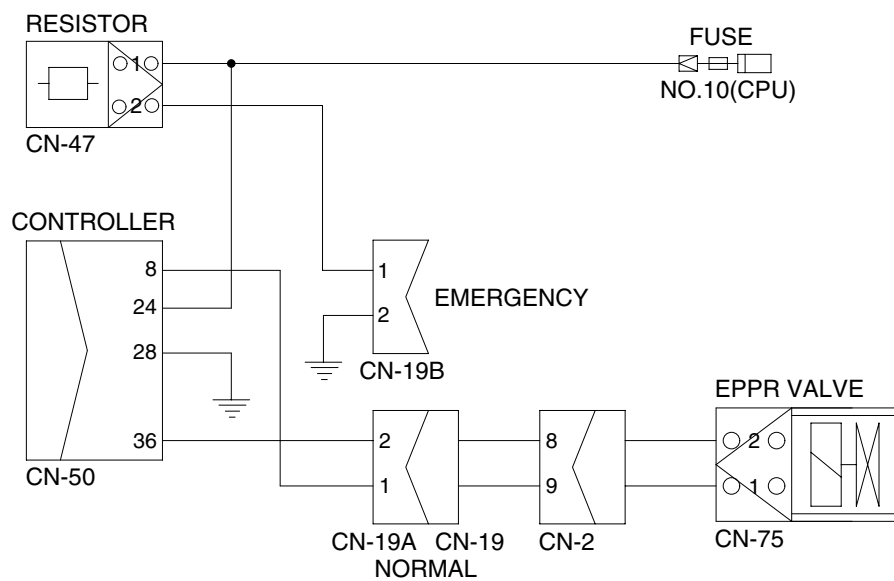

14W7A6MS01

2) TEST PROCEDURE

(1) Test 4 : Check electric current at EPPR valve at S-mode

- ① Install multimeter as figure.
- ② Start engine.
- ③ Set the accel dial at "10"(max)
- ④ Set S-mode with 1800 ± 50 rpm.
- ⑤ Check electric current.

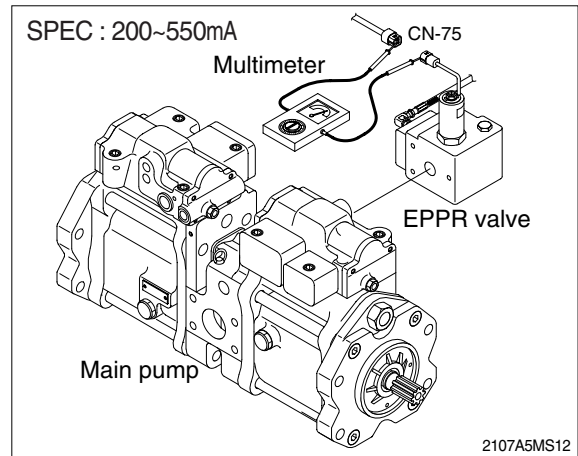

(2) Test 5 : Check pressure at EPPR valve at S-mode

- ① Connect pressure gauge at EPPR valve.
- ② Start engine.
- ③ Set the accel dial at "10"(max)
- ④ Set S-mode with 1800 ± 50 rpm.
- ⑤ Operate bucket lever completely push or pull.
- ⑥ Hold arm lever at the end of stroke.
- ⑦ Check pressure at relief position.

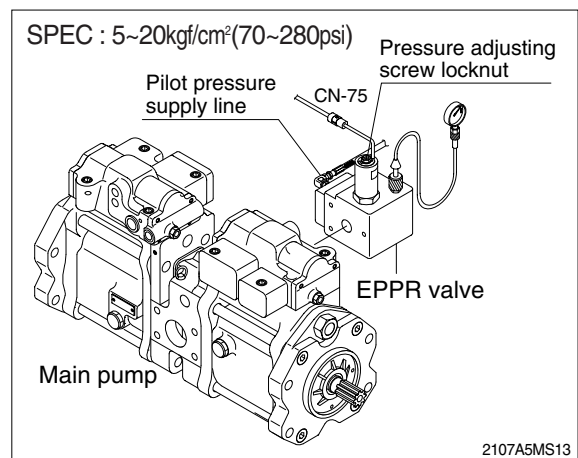

3. MALFUNCTION OF CLUSTER OR MODE SELECTION SYSTEM

※ Before carrying out below procedure, check all the related connectors are properly inserted.

1) INSPECTION PROCEDURE

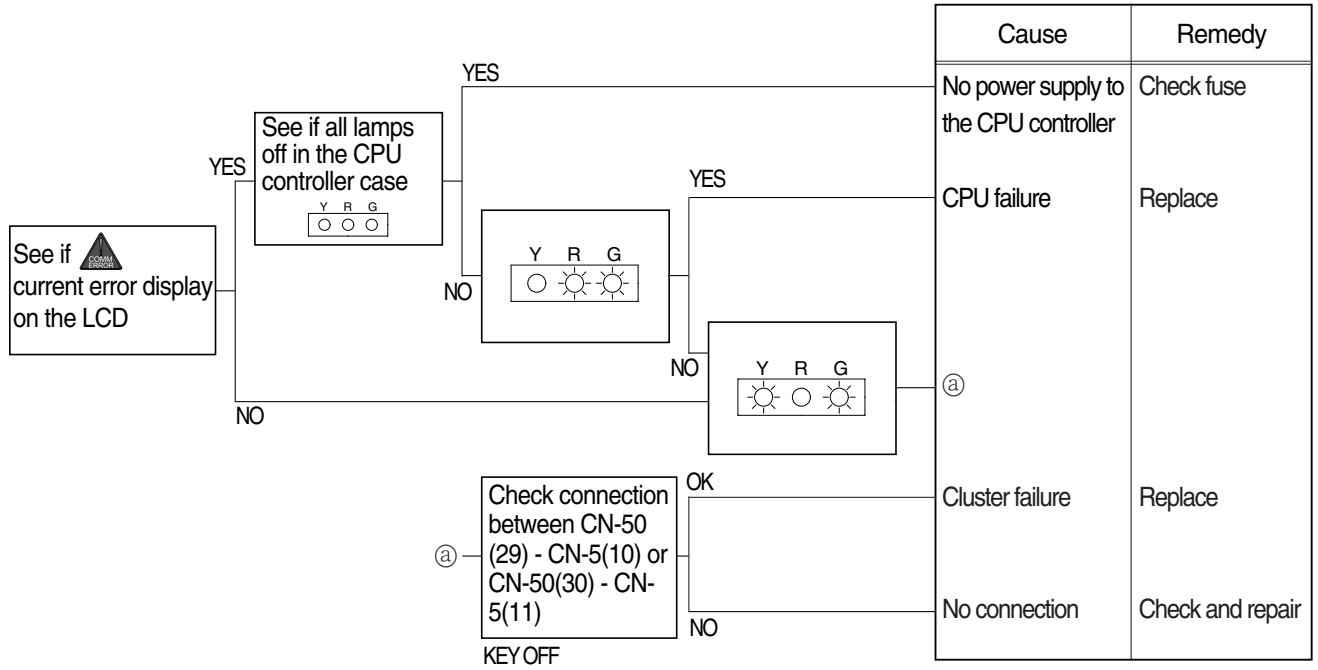

Wiring diagram

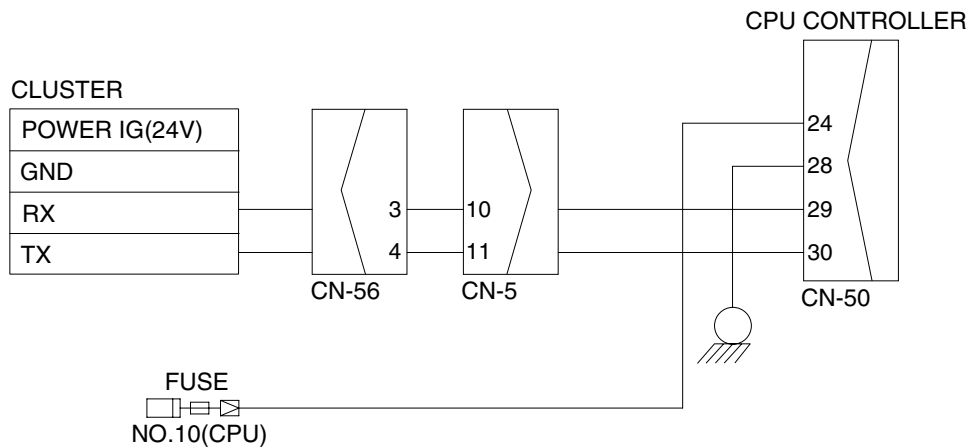

4. AUTO DECEL SYSTEM DOES NOT WORK

※ Before carrying out below procedure, check all the related connectors are properly inserted.

1) INSPECTION PROCEDURE

		Cause	Remedy
<div style="border: 1px solid black; padding: 5px; width: fit-content;"> Check resistance between CN-51 (1)-GND </div> <p>SPEC : Actuator operating : 11~13V Actuator stop : 0~2V See TEST 6</p>	YES	Defective CPU controller	Replace
	NO	Short circuit or poor connection between CN-51(1)- pressure switches	Replace or repair
	NO	Defective auto decel pressure switch	Replace

Wiring diagram

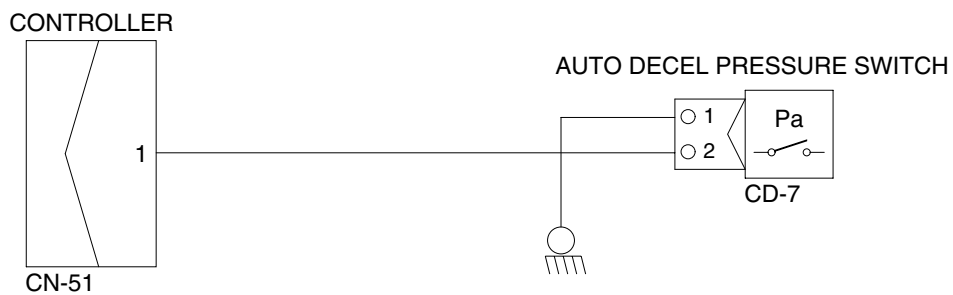

1607A6MS10

2) TEST PROCEDURE

(1) **Test 6** : Check voltage at CN-51(1) and ground.

- ① Prepare 1 piece of thin sharp pin, steel or copper.
- ② Starting key ON.
- ③ Insert prepared pin to rear side of connectors : One pin to (1) of CN-51.
- ④ Check voltage as figure.

SPEC : Actuator stop : 0~2V
Actuator operating : 11~13V

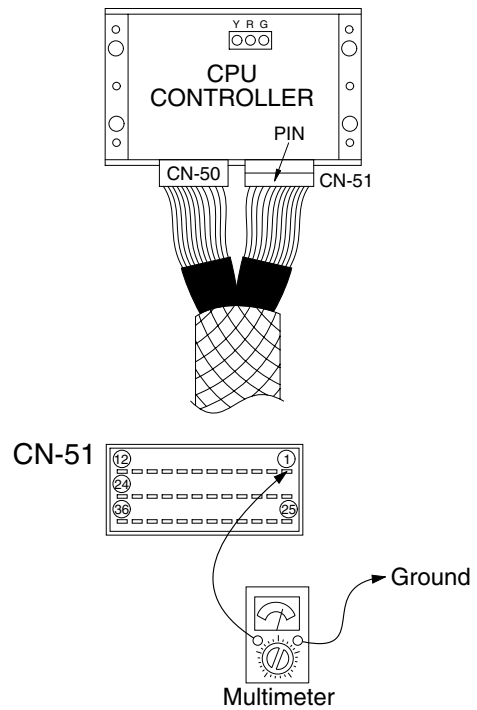

1607A6MS11

5. MALFUNCTION OF WARMING UP

※ Before carrying out below procedure, check all the related connectors are properly inserted.

1) INSPECTION PROCEDURE

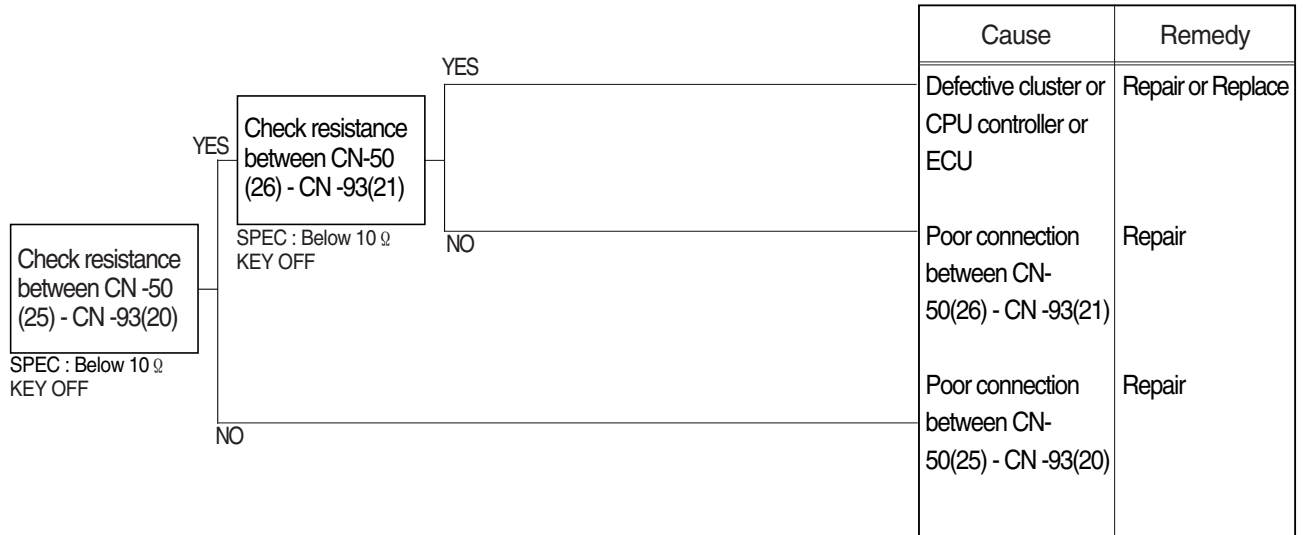

Wiring diagram

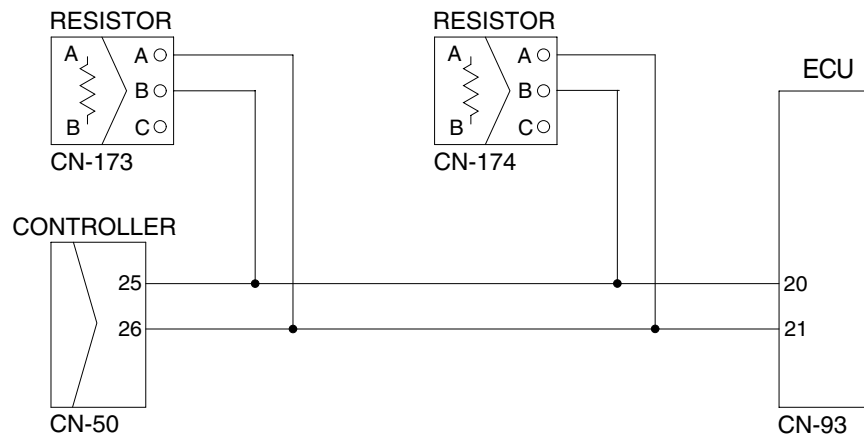

14W7A6ES03

6. MALFUNCTION OF POWER MAX

※ Before carrying out below procedure, check all the related connectors are properly inserted.

1) INSPECTION PROCEDURE

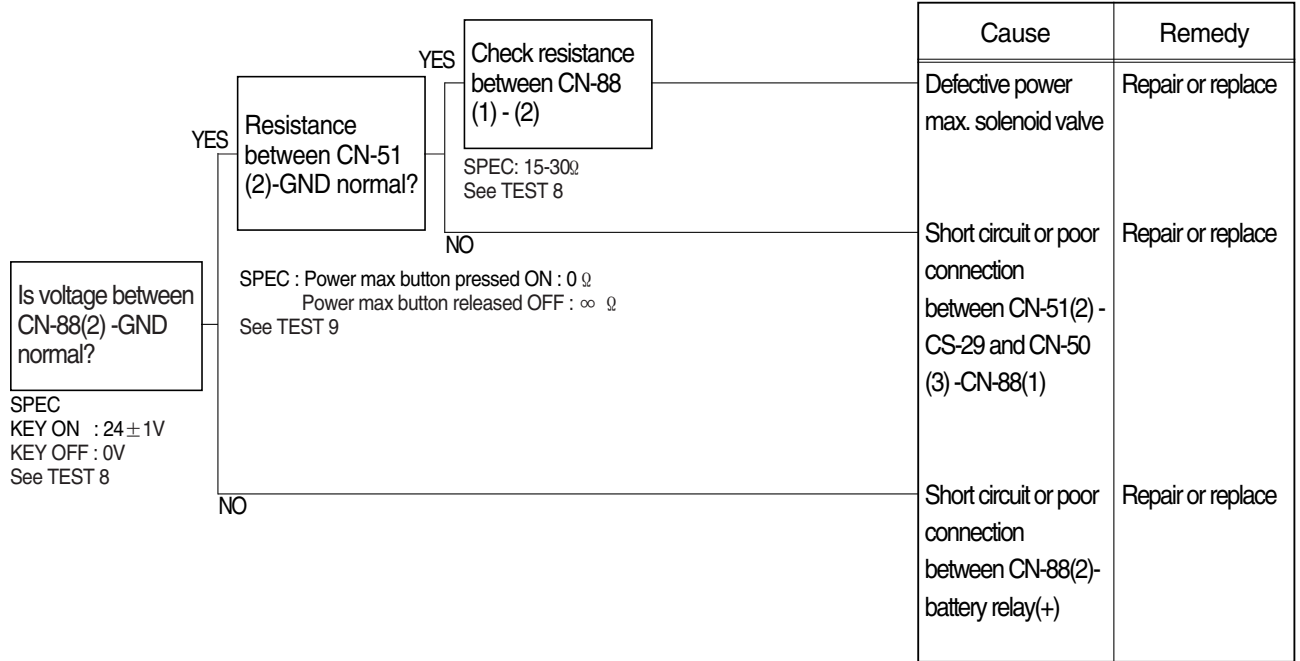

Wiring diagram

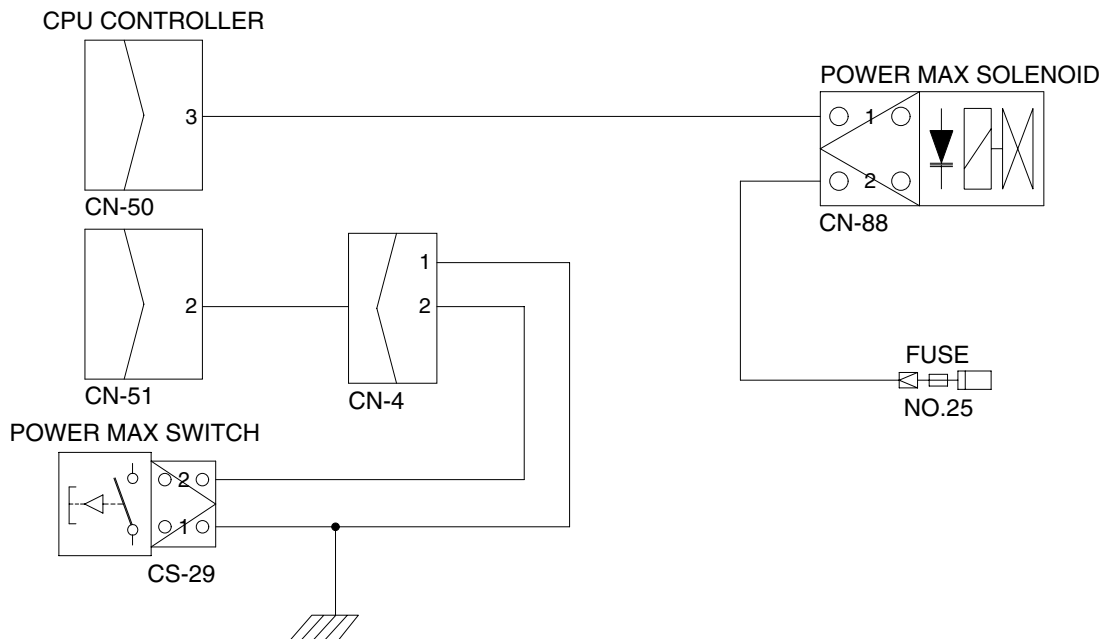

50076MS04

2) TEST PROCEDURE

(1) **Test 8:** Check voltage between connector CN-88 - GND.

- ① Start key ON.
- ② Disconnect connector CN-88 from power max solenoid valve.
- ③ Check voltage as figure.

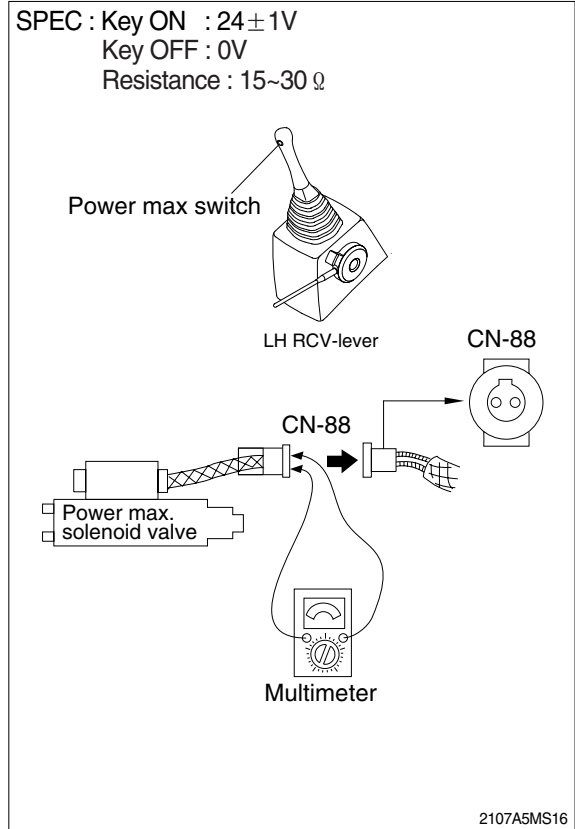

(2) **Test 9:** Check resistance between connector CN-51(2)-GND.

- ① Starting key OFF.
- ② Remove CPU controller and disconnect connector CN-51 from CPU controller.
- ③ Check resistance as figure.

