

GROUP 2 ELECTRICAL CIRCUIT (1/2)

FRAME HARNESS

| NO. | DESTINATION |
|-----|---------------------|
| 1 | AC CONTROLLER GND |
| 2 | REAR WIPER MOTOR SW |
| 3 | AC 24V |
| 4 | NC |
| 5 | AC CONTROL |
| 6 | AC CONTROL |
| 7 | AC CONDENSER FAN |
| 8 | ILLUMINATION |
| 9 | NC |
| 10 | BEACON LAMP |
| 11 | CABIN LIGHT |
| 12 | NC |

| NO. | DESTINATION |
|-----|----------------------|
| 1 | CASSETTE RADIO 24V |
| 2 | ILLUMINATION |
| 3 | NC |
| 4 | NC |
| 5 | CASSETTE ROOM LAMP B |
| 6 | NC |
| 7 | CASSETTE GND |
| 8 | NC |
| 9 | BEACON LAMP |
| 10 | CABIN LIGHT |
| 11 | NC |
| 12 | NC |

| NO. | DESTINATION |
|-----|--------------|
| 1 | HORN SW |
| 2 | HORN SW |
| 3 | NC |
| 4 | INT. SIG. |
| 5 | ACCEL. SW(L) |
| 6 | ACCEL. SW(R) |
| 7 | ACCEL. SW(L) |
| 8 | SPARE SW |

| NO. | DESTINATION |
|-----|-----------------------|
| 1 | SPARE SW |
| 2 | SPARE SW |
| 3 | BEACON LAMP 24V |
| 4 | BEACON LAMP SW |
| 5 | BREAKER SW 24V |
| 6 | BREAKER SW |
| 7 | SPARE SW |
| 8 | SPARE SW |
| 9 | START KEY (START SIG) |
| 10 | START KEY (ACC) |
| 11 | START KEY (SIG) |
| 12 | START KEY (COM) |

| NO. | DESTINATION |
|-----|------------------|
| 1 | ILLUMINATION |
| 2 | HEAD LIGHT SIG |
| 3 | WIPER DRIVE SW |
| 4 | PRE HEAT |
| 5 | SW PANEL SW |
| 6 | CABIN LIGHT 24V |
| 7 | ILLUMINATION 24V |
| 8 | HEAD LIGHT 24V |
| 9 | WASHER SIG |
| 10 | GND |
| 11 | WORK LAMP SW |
| 12 | CABIN LIGHT 24V |
| 13 | SEAT HEATER |
| 14 | NC |
| 15 | NC |

| NO. | DESTINATION |
|-----|--------------|
| 1 | HORN SW |
| 2 | HORN SW |
| 3 | NC |
| 4 | INT. SIG. |
| 5 | ACCEL. SW(L) |
| 6 | ACCEL. SW(R) |
| 7 | ACCEL. SW(L) |
| 8 | SPARE SW |

| NO. | DESTINATION |
|-----|--------------------|
| 1 | TOCK COOLING SW |
| 2 | TOCK COOLING SW SW |
| 3 | OVERLOAD SW |
| 4 | WIPER MOTOR 24V |
| 5 | GND |
| 6 | CHARGE LIGHT 24V |
| 7 | CHARGE LIGHT SW |
| 8 | WIPER DRIVE SW |
| 9 | WIPER SW |
| 10 | WIPER SW |
| 11 | WASHER PUMP |
| 12 | TRAVEL MODE |

| NO. | DESTINATION |
|-----|---------------------|
| 1 | WASHER SIG |
| 2 | WIPER MOTOR |
| 3 | WIPER MOTOR 24V |
| 4 | WIPER MOTOR CONT |
| 5 | COCKING SW |
| 6 | HOOR METER SW |
| 7 | HOOR METER SW |
| 8 | SHIELD |
| 9 | CLUSTER GND |
| 10 | CLUSTER SERIAL (RX) |
| 11 | CLUSTER SERIAL (TX) |
| 12 | WIP SELECT SW |
| 13 | FLASHER(L) |
| 14 | GND |
| 15 | FLASHER(R) |

| NO. | DESTINATION |
|-----|-------------|
| 1 | MULTI SW |
| 2 | HAZARD SW |
| 3 | MULTI SW |
| 4 | MULTI SW |
| 5 | MULTI SW |
| 6 | MULTI SW |
| 7 | MULTI SW |
| 8 | MULTI SW |
| 9 | MULTI SW |
| 10 | MULTI SW |
| 11 | MULTI SW |
| 12 | MULTI SW |
| 13 | MULTI SW |
| 14 | MULTI SW |
| 15 | MULTI SW |

| NO. | DESTINATION |
|-----|-------------|
| 1 | PARKING SW |
| 2 | LAMP 24V |
| 3 | HAZARD SW |
| 4 | DO SW |
| 5 | DO SW |
| 6 | DO SW |
| 7 | DO SW |
| 8 | NC |
| 9 | GND |
| 10 | NC |

| NO. | DESTINATION |
|-----|-------------|
| 1 | MULTI SW |
| 2 | HAZARD SW |
| 3 | MULTI SW |
| 4 | MULTI SW |
| 5 | MULTI SW |
| 6 | MULTI SW |
| 7 | MULTI SW |
| 8 | MULTI SW |
| 9 | MULTI SW |
| 10 | MULTI SW |
| 11 | MULTI SW |
| 12 | MULTI SW |
| 13 | MULTI SW |
| 14 | MULTI SW |
| 15 | MULTI SW |

| NO. | DESTINATION |
|-----|-------------|
| 1 | MULTI SW |
| 2 | HAZARD SW |
| 3 | MULTI SW |
| 4 | MULTI SW |
| 5 | MULTI SW |
| 6 | MULTI SW |
| 7 | MULTI SW |
| 8 | MULTI SW |
| 9 | MULTI SW |
| 10 | MULTI SW |
| 11 | MULTI SW |
| 12 | MULTI SW |
| 13 | MULTI SW |
| 14 | MULTI SW |
| 15 | MULTI SW |

| NO. | DESTINATION |
|-----|-----------------|
| 1 | POWER MAX SW |
| 2 | POWER MAX SW |
| 3 | OFF DECEL SW |
| 4 | OFF DECEL SW |
| 5 | NC |
| 6 | SAFETY SW (COM) |
| 7 | SAFETY SW (NC) |
| 8 | SAFETY SW (NO) |

| NO. | DESTINATION |
|-----|----------------|
| 1 | REAR COMBI-RH |
| 2 | FRONT COMBI-RH |
| 3 | REAR COMBI-LH |
| 4 | FRONT COMBI-LH |

| NO. | DESTINATION |
|-----|----------------|
| 1 | REAR COMBI-RH |
| 2 | FRONT COMBI-RH |
| 3 | REAR COMBI-LH |
| 4 | FRONT COMBI-LH |

| NO. | DESTINATION |
|-----|----------------|
| 1 | REAR COMBI-RH |
| 2 | FRONT COMBI-RH |
| 3 | REAR COMBI-LH |
| 4 | FRONT COMBI-LH |

| NO. | DESTINATION |
|-----|----------------|
| 1 | REAR COMBI-RH |
| 2 | FRONT COMBI-RH |
| 3 | REAR COMBI-LH |
| 4 | FRONT COMBI-LH |

| NO. | DESTINATION |
|-----|----------------|
| 1 | REAR COMBI-RH |
| 2 | FRONT COMBI-RH |
| 3 | REAR COMBI-LH |
| 4 | FRONT COMBI-LH |

| NO. | DESTINATION |
|-----|----------------|
| 1 | REAR COMBI-RH |
| 2 | FRONT COMBI-RH |
| 3 | REAR COMBI-LH |
| 4 | FRONT COMBI-LH |

| NO. | DESTINATION |
|-----|----------------|
| 1 | REAR COMBI-RH |
| 2 | FRONT COMBI-RH |
| 3 | REAR COMBI-LH |
| 4 | FRONT COMBI-LH |

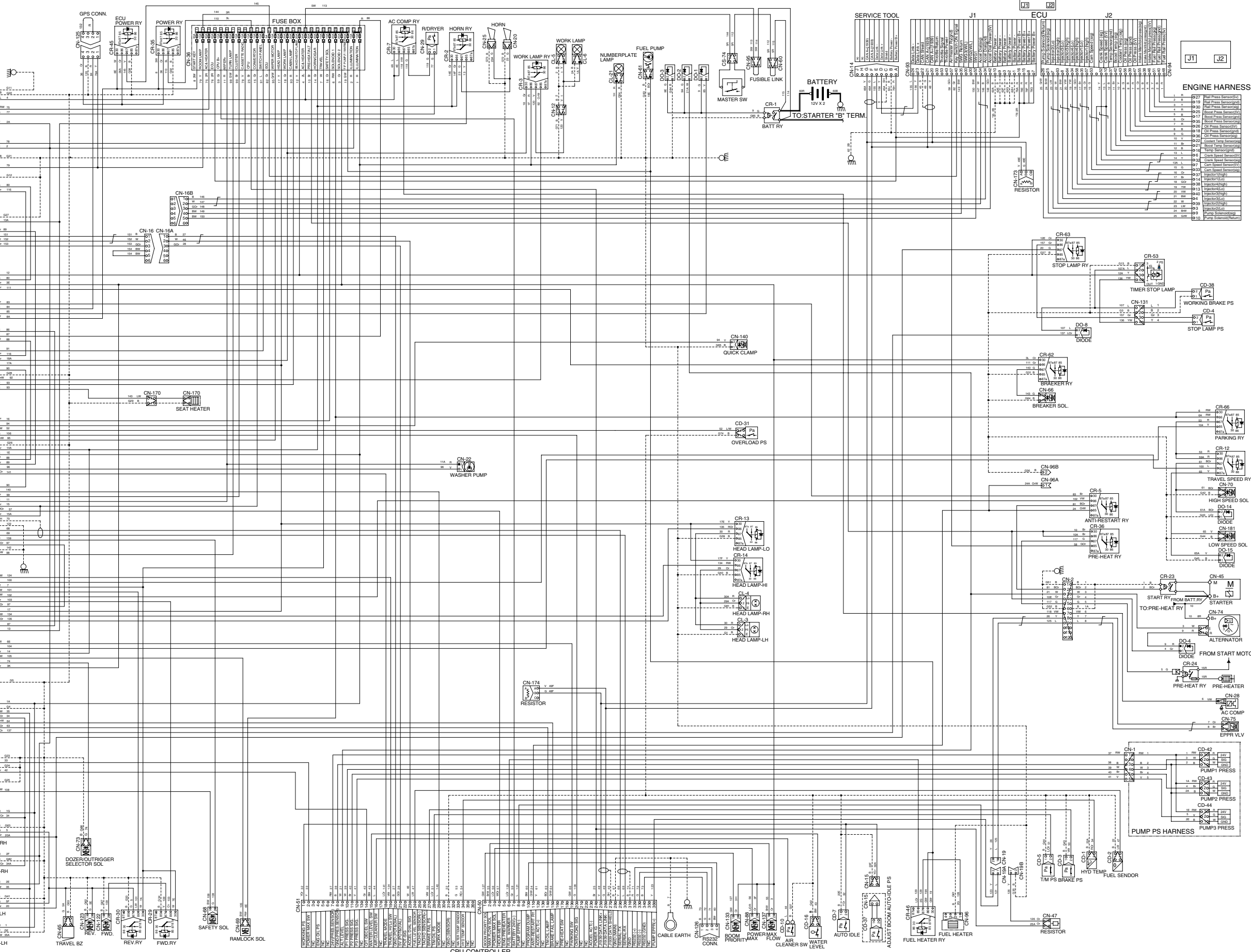

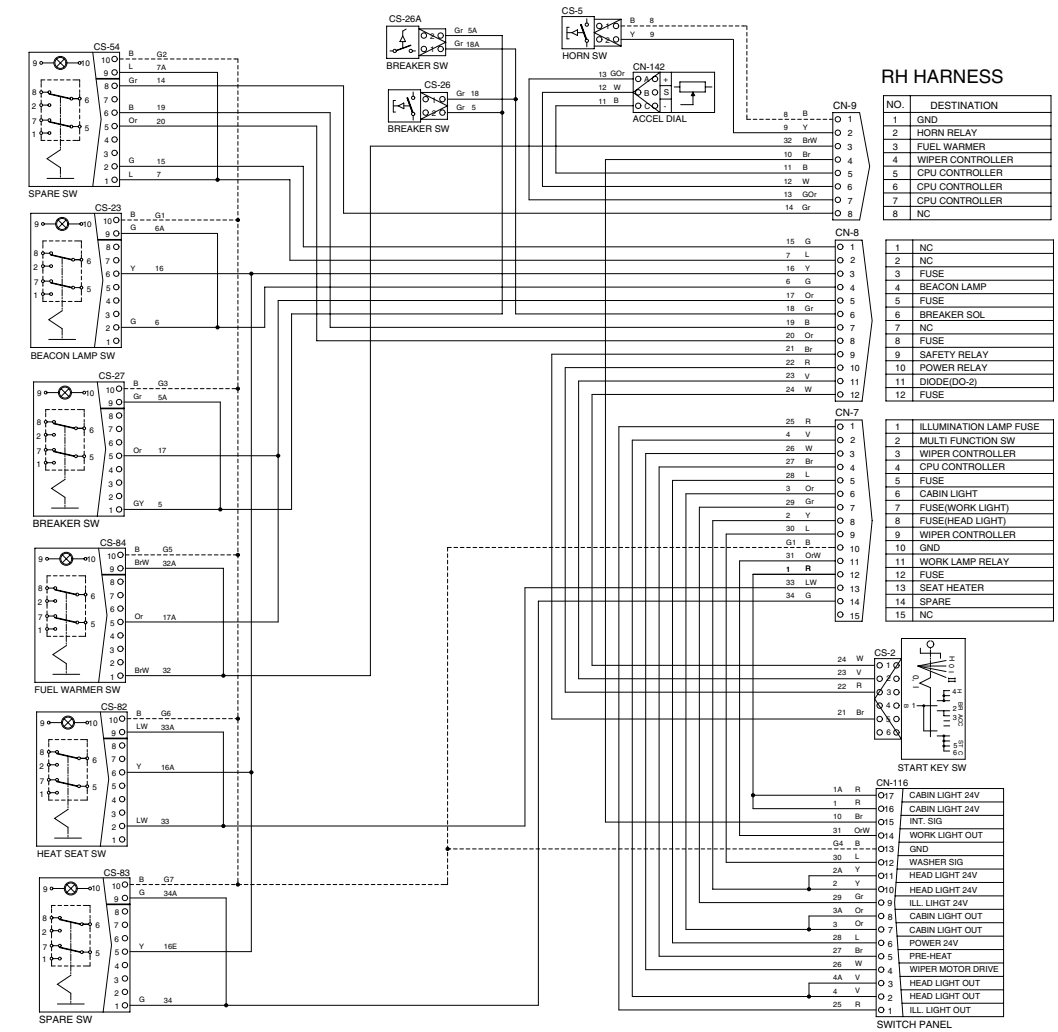
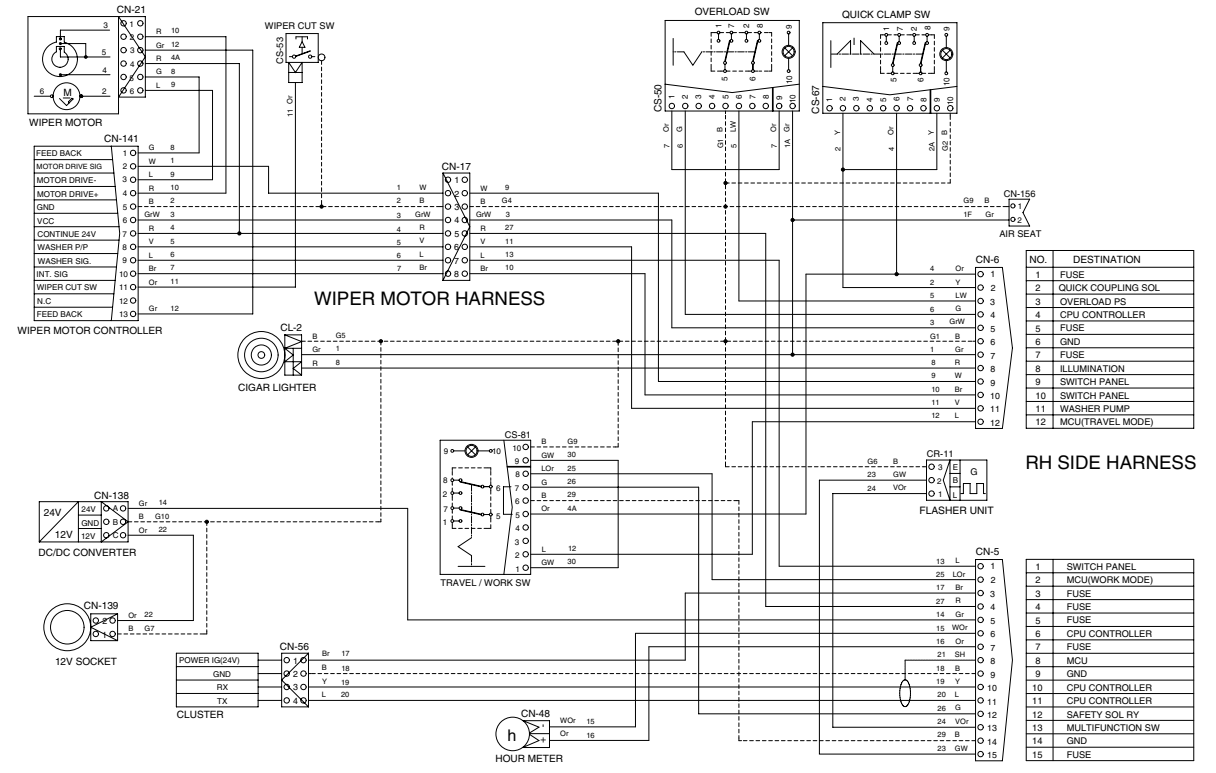
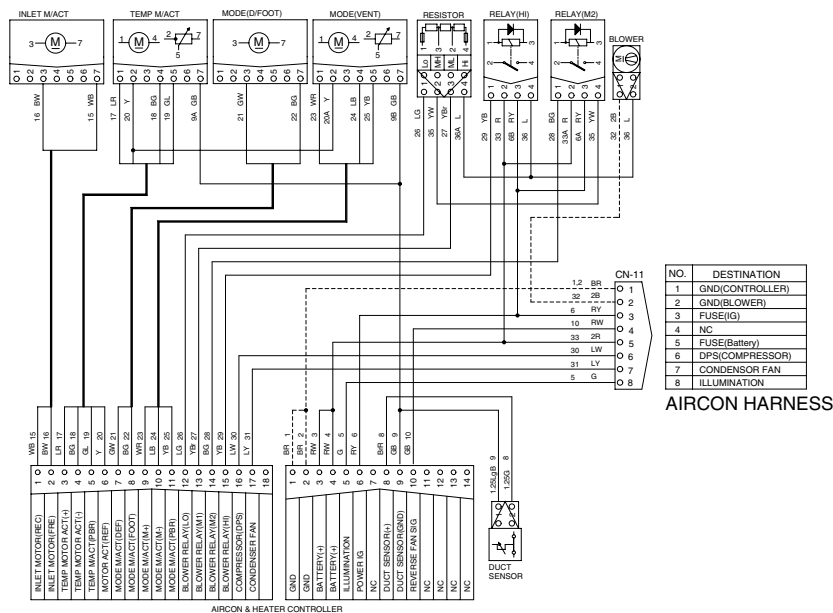
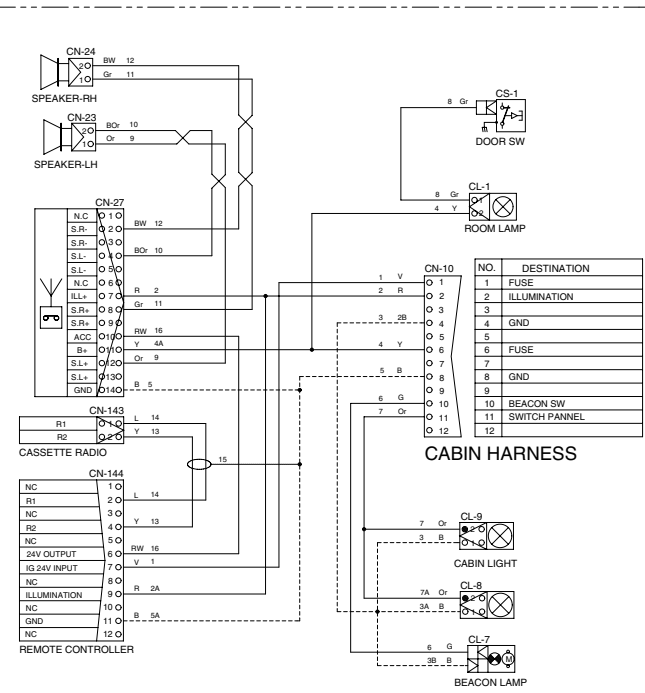
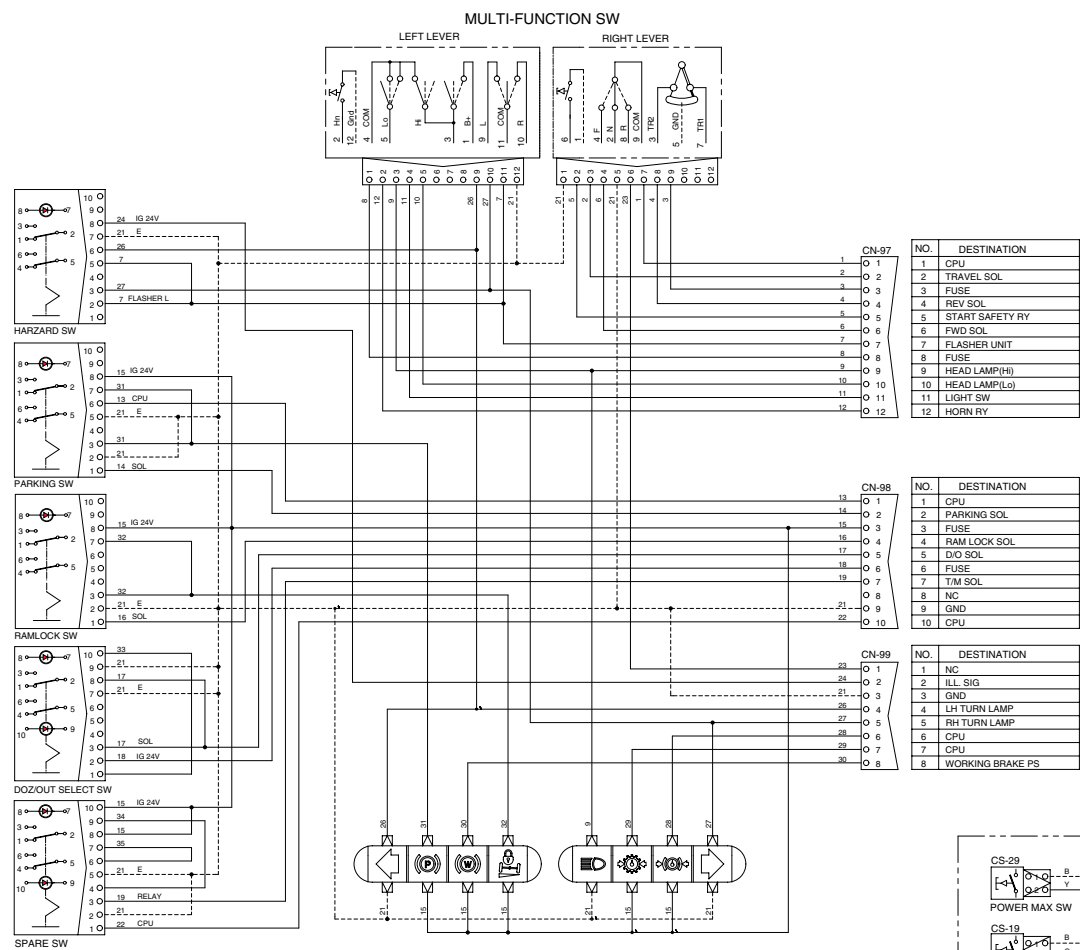



1. POWER CIRCUIT

The negative terminal of battery is grounded to the machine chassis through master switch.
When the start switch is in the OFF position, the current flows from the positive battery terminal as shown below.

1) OPERATING FLOW

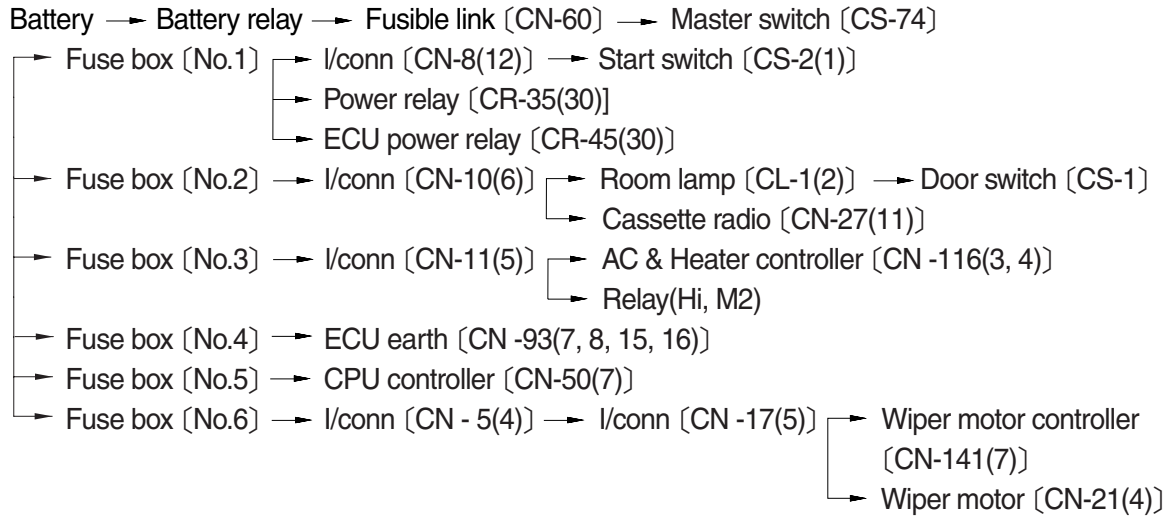

2) CHECK POINT

| Engine | Start switch | Check point | Voltage |
|--------|--------------|------------------------|----------|
| OFF | OFF | ① - GND (Battery 1EA) | 10~12.5V |
| | | ② - GND (Battery 2EA) | 20~25V |
| | | ③ - GND (Battery 2EA) | 20~25V |
| | | ④ - GND (Fusible link) | 20~25V |

※ GND : Ground

POWER CIRCUIT

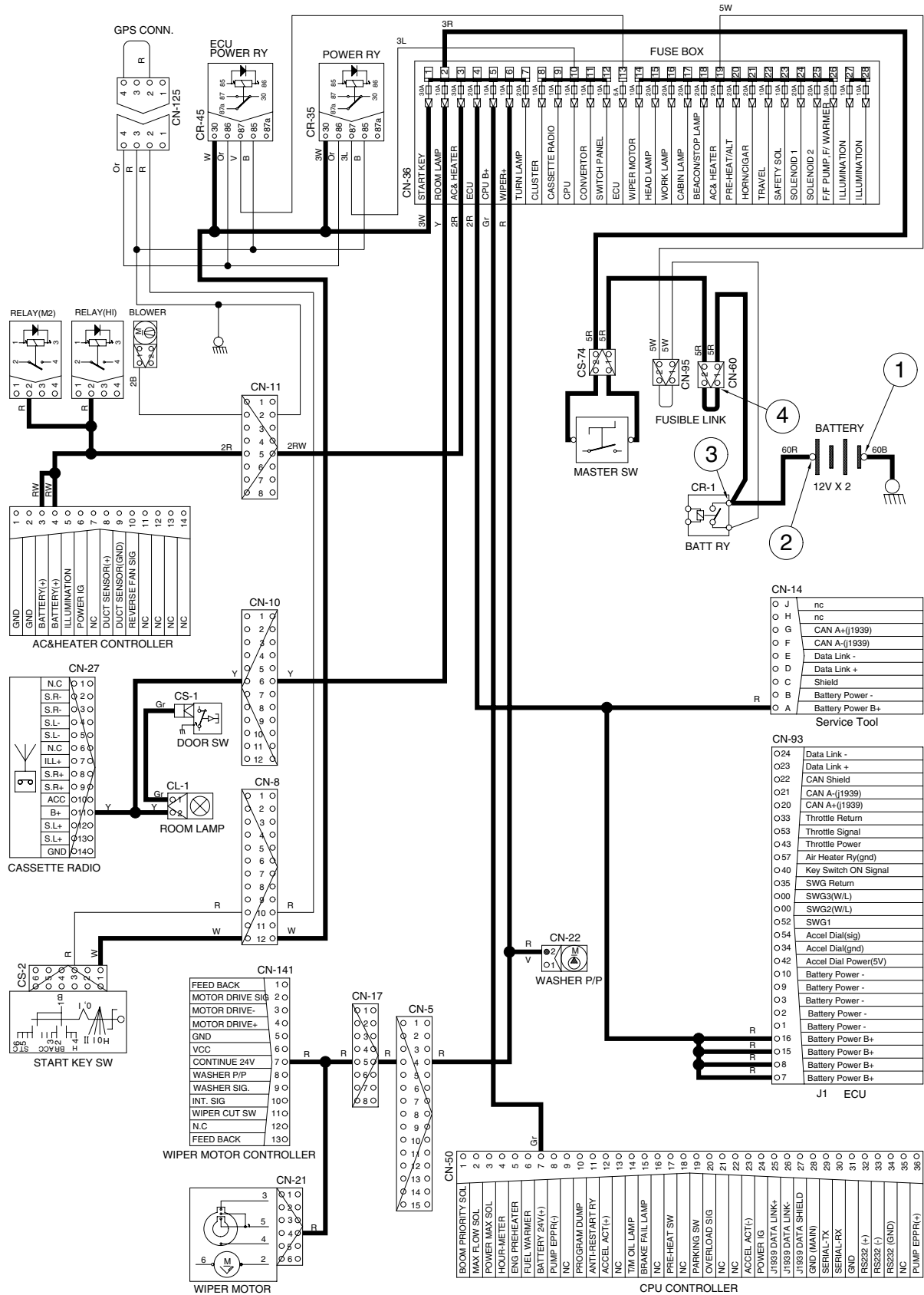

14W7A4EL03

2. STARTING CIRCUIT

1) OPERATING FLOW

Battery(+) terminal → Battery relay〔CR-1〕 → Fusible link 〔CN-60〕 → Master switch〔CS-74〕
 → Fuse box 〔No.1〕 → I/conn 〔CN-8(12)〕 → Start switch 〔CS-2(1)〕

(1) When start key switch is in ON position

→ Start switch ON 〔CS-2(2)〕 → I/conn 〔CN-8(11)〕 → Battery relay 〔CR-1〕
 → Battery relay operating (All power is supplied with the electric component)
 → Start switch ON 〔CS-2(3)〕 → I/conn 〔CN-8(10)〕 → Power relay 〔CR-35(86) → (87)〕
 → Fuse box 〔No.10〕

(2) When start key switch is in START position

Start switch START 〔CS-2(5)〕 → I/conn 〔CN-8(9)〕 → Anti-restart relay 〔CR-5(86) → (87)〕
 → I/conn 〔CN-2(2)〕 → Start relay 〔CR-23〕

2) CHECK POINT

| Engine | Start switch | Check point | Voltage |
|-----------|--------------|---|---------|
| OPERATING | START | ① - GND(Battery) ② - GND(Start key) ③ - GND(Battery relay M4) ④ - GND(Starter B+) ⑤ - GND(Starter M) ⑥ - GND(Start relay) ⑦ - GND(Battery relay M8) | 20~25V |

※ GND : Ground

STARTING CIRCUIT

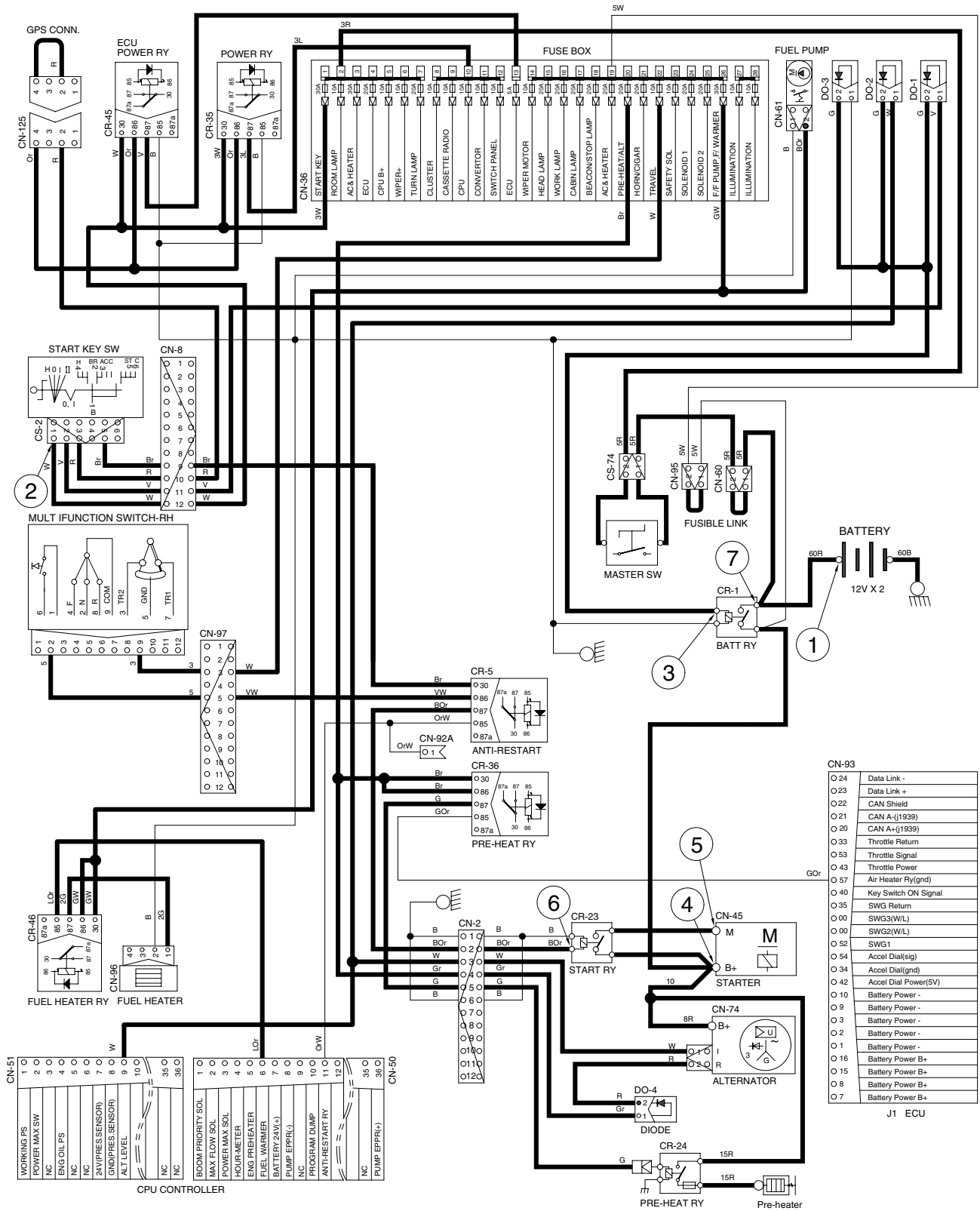

14W74AEL04

3. CHARGING CIRCUIT

When the starter is activated and the engine is started, the operator releases the key switch to the ON position.

Charging current generated by operating alternator flows into the battery through the battery relay (CR-1).

The current also flows from alternator to each electrical component and controller through the fuse box.

1) OPERATING FLOW

(1) Warning flow

Alternator "I" terminal → I/conn [CN-2(3)] → CPU alternator level [CN-51(9)]

Cluster charging warning lamp(Via serial interface)

(2) Charging flow

Alternator "B+" terminal → Battery relay(M8) → Battery(+) terminal
 → Fusible link [CN-60] → Master switch[CS-74]
 → Fuse box

2) CHECK POINT

| Engine | Start switch | Check point | Voltage |
|--------|--------------|---|---------|
| Run | ON | ① - GND(Battery voltage) ② - GND(Battery relay) ③ - GND(Alternator B+ terminal) ④ - GND(Alternator I terminal) ⑤ - GND(CPU) | 20~30V |

※ GND : Ground

CHARGING CIRCUIT

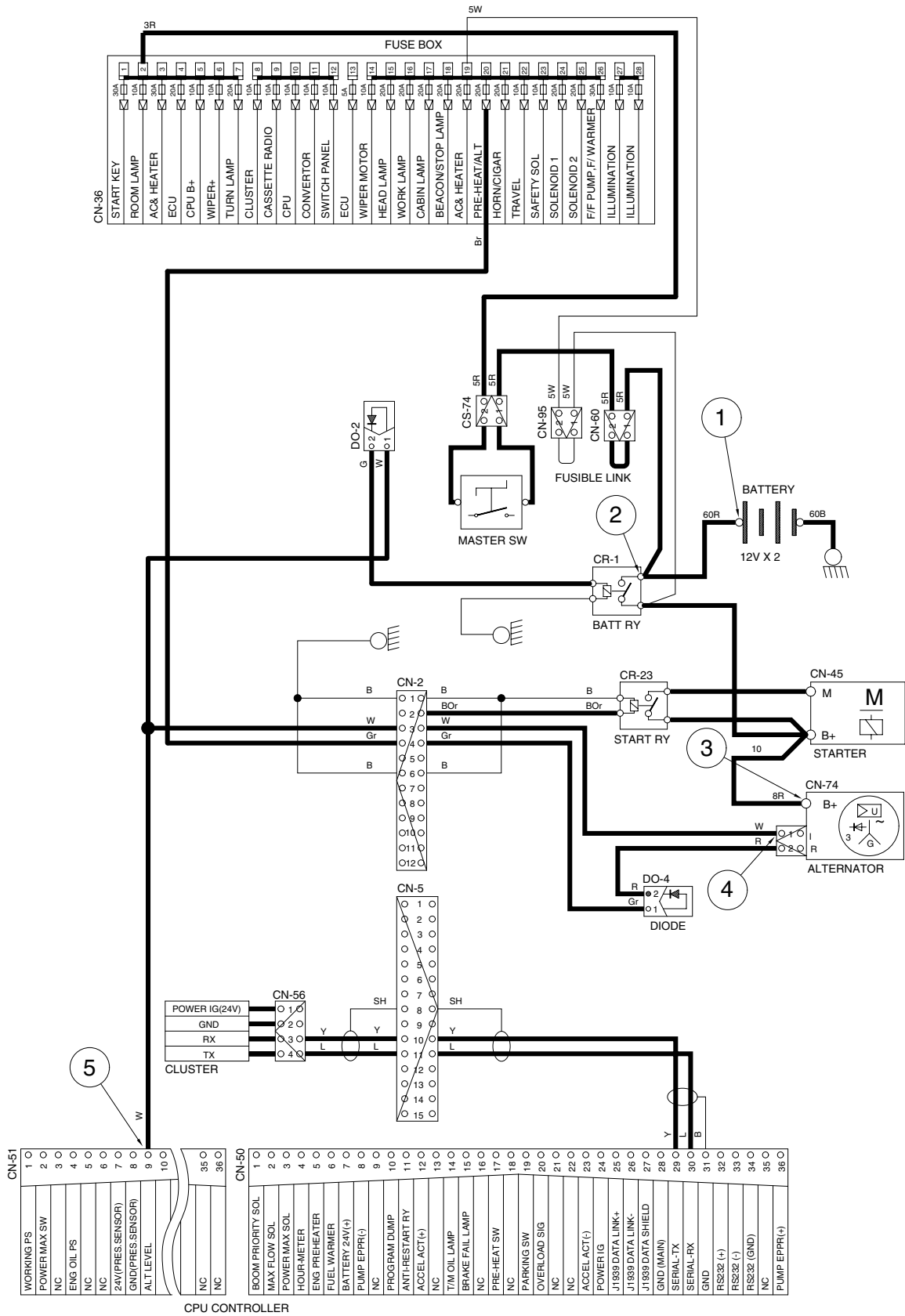

14W7A4EL05

4. HEAD AND WORK LIGHT CIRCUIT

1) OPERATING FLOW

Fuse box (No.15) → I/conn [CN-7(8)] → Switch panel [CN-116(10,11)]

Fuse box (No.16) → I/conn [CN-7(7)] → Switch panel [CN-116(9)]

(1) Main light switch ON : 1st step

Head light switch ON [CN-116(2,3)] → I/conn [CN-7(2)] → I/conn [CN-97(11)] →

Multifunction sw left lever(4) → (5) → [CN-97(10)] → Head light relay [CR-13(86)→(87)] →

Head light ON [CL-3(1), CL-4(1)] : Head lamp ON

(2) Main light switch ON : 2nd step

Work light switch ON [CN-116(14)] → I/conn [CN-7(11)] → Work light relay [CR-3(86)→(87)]

→ I/conn [CN-12(1)] → Work light ON [CL-5(2), CL-6(2)]

2) CHECK POINT

| Engine | Start switch | Check point | Voltage |
|--------|--------------|---|---------|
| STOP | ON | ① - GND(Fuse box) ② - GND(Switch power input) ③ - GND(Switch power output) ④ - GND(Head light relay) | 20~25V |
| STOP | ON | ⑤ - GND (Head light) ⑥ - GND(Fuse box) ⑦ - GND(Switch power input) ⑧ - GND(Switch power output) ⑨ - GND(Work light) | 20~25V |

※ GND : Ground

HEAD AND WORK LIGHT CIRCUIT

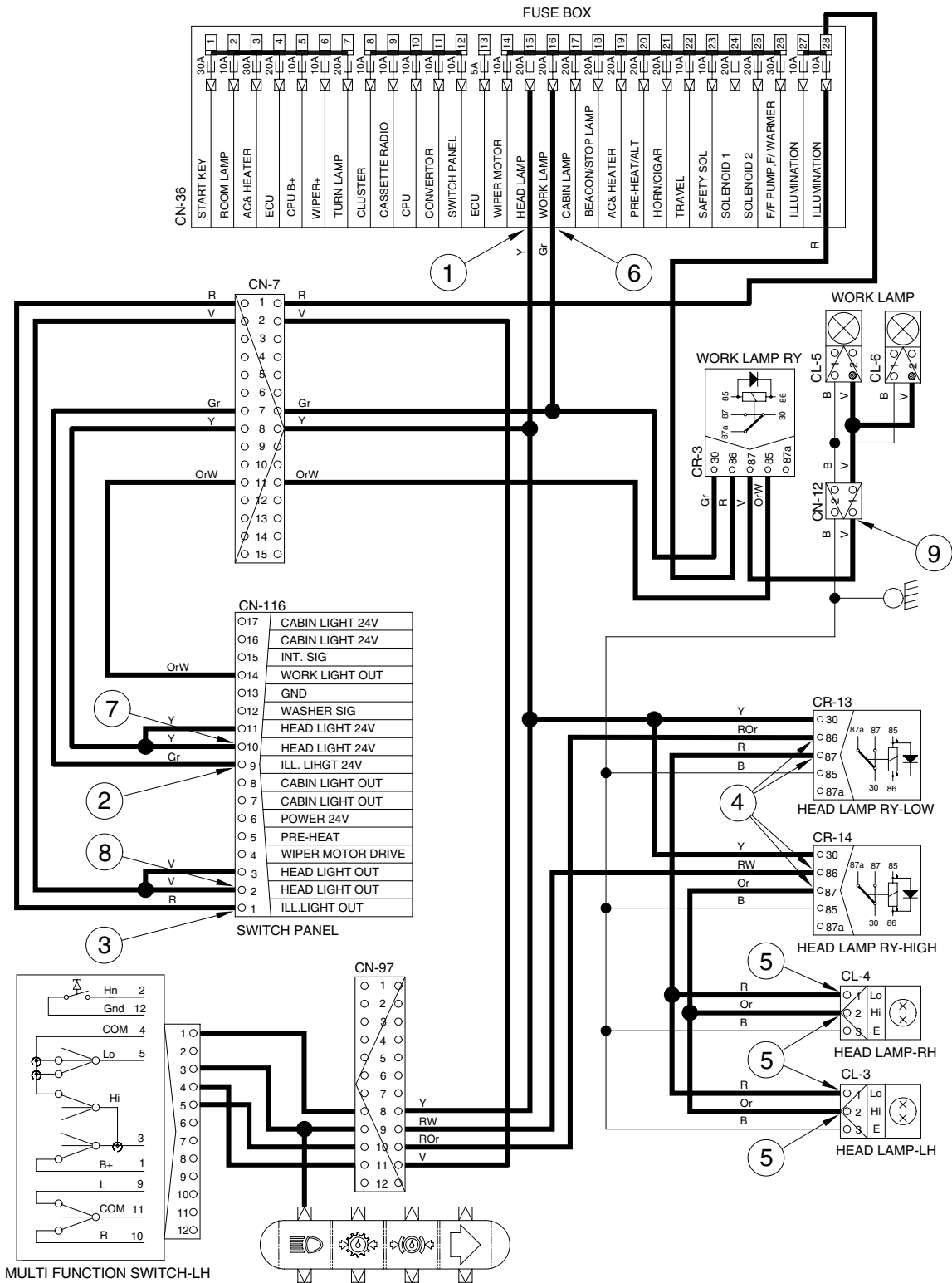

5. BEACON LAMP AND CAB LIGHT CIRCUIT

1) OPERATING FLOW

Fuse box (No.18) → I/conn [CN-8(3)] → Beacon lamp switch [CS-23(6)]

Fuse box (No.17) → I/conn [CN-7(12)] → Switch panel [CN-116(16, 17)]

(1) Beacon lamp switch ON

Beacon lamp switch ON [CS-23(2)] → Switch Indicator lamp ON [CS-23(9)]
 → I/conn [CN-8(4)] → I/conn [CN-10(10)]
 → Beacon lamp ON [CL-7]

(2) Cab light switch ON

Cab light switch ON [CN-116(7, 8)] → I/conn [CN-7(6)] → I/conn [CN-10(11)]
 → Cab light ON [CL-8(2), CL-9(2)]

2) CHECK POINT

| Engine | Start switch | Check point | Voltage |
|--------|--------------|--|---------|
| STOP | ON | ① - GND(Fuse box) ② - GND(Switch power input) ③ - GND(Switch power output) ④ - GND(Beacon lamp) | 20~25V |
| STOP | ON | ⑤ - GND(Fuse box) ⑥ - GND(Switch power input) ⑦ - GND(Switch power output) ⑧ - GND(Cab light) | 20~25V |

※ GND : Ground

BEACON LAMP AND CAB LIGHT CIRCUIT

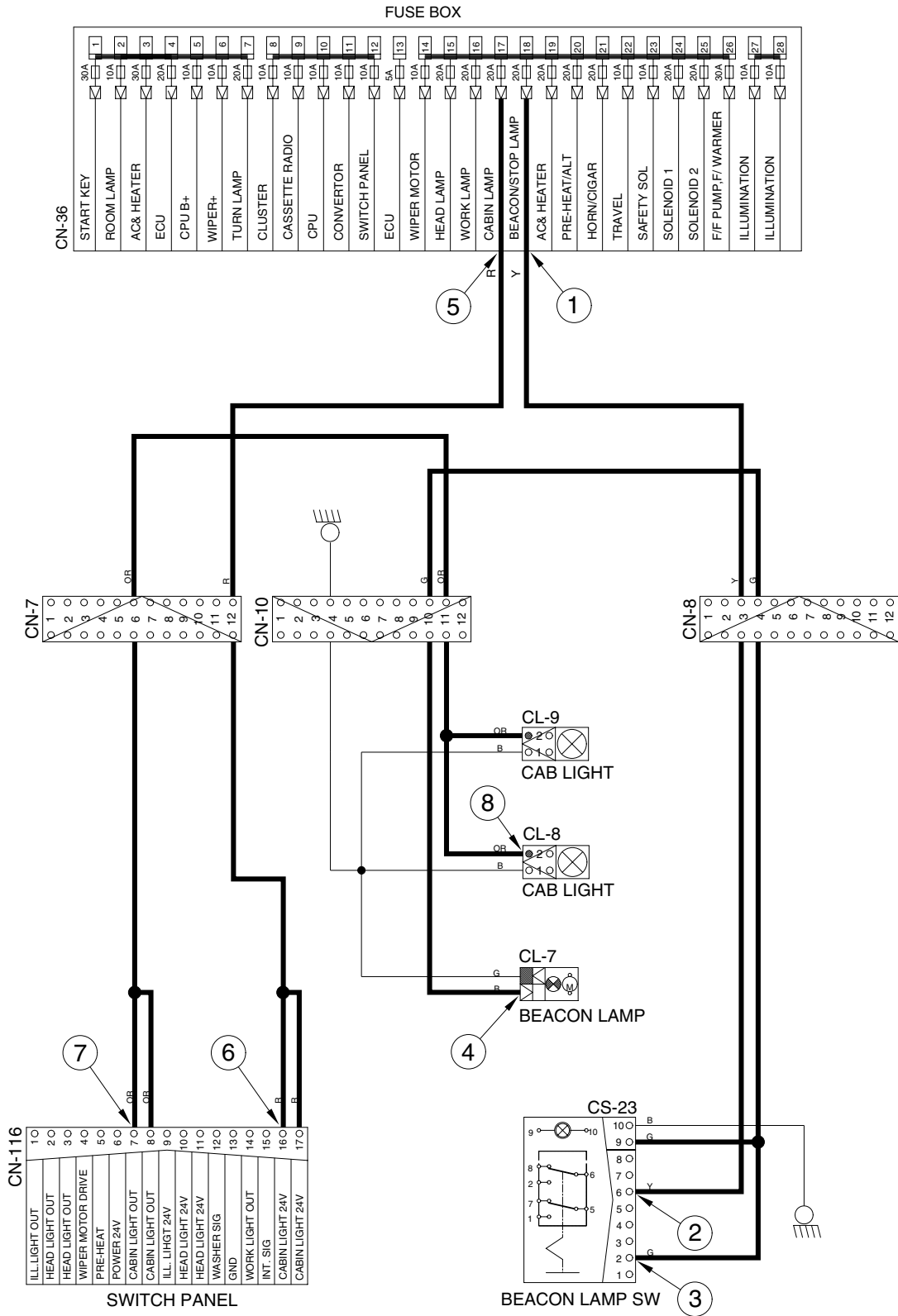

14W7A4EL07

6. WIPER AND WASHER CIRCUIT

1) OPERATING FLOW

(1) Key switch ON

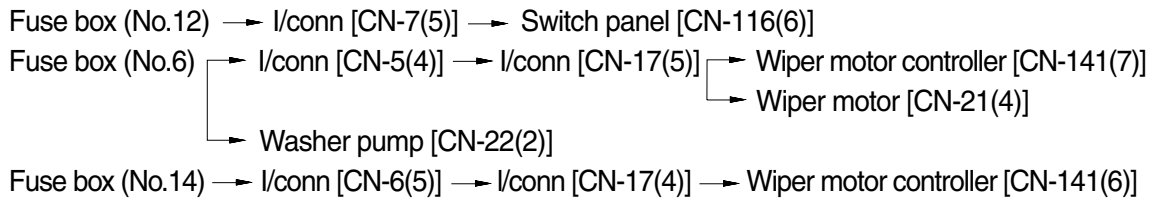

(2) Wipe switch ON : 1st step(Intermittent)

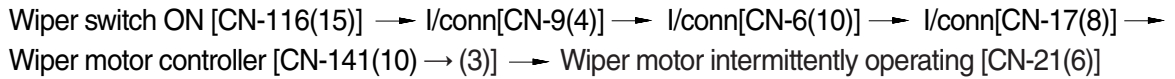

(3) Wiper switch ON : 2nd step(Low speed)

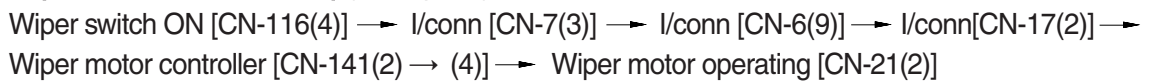

(4) Washer switch ON

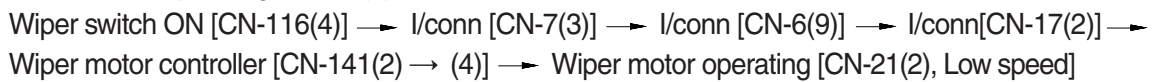
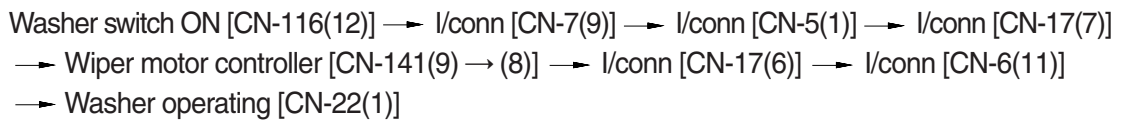

(5) Auto parking(When switch OFF)



2) CHECK POINT

| Engine | Start switch | Check point | Voltage |
|--------|--------------|------------------------------|----------|
| STOP | ON | ① - GND(Fuse box) | 24V |
| | | ② - GND(Switch power input) | |
| | | ③ - GND(Switch power output) | 0~5V |
| | | ④ - GND(Wiper Power input) | |
| | | ⑤ - GND(Wiper power output) | 24V |
| | | ⑥ - GND(Wiper motor) | 0 or 24V |

※ GND : Ground

WIPER AND WASHER CIRCUIT

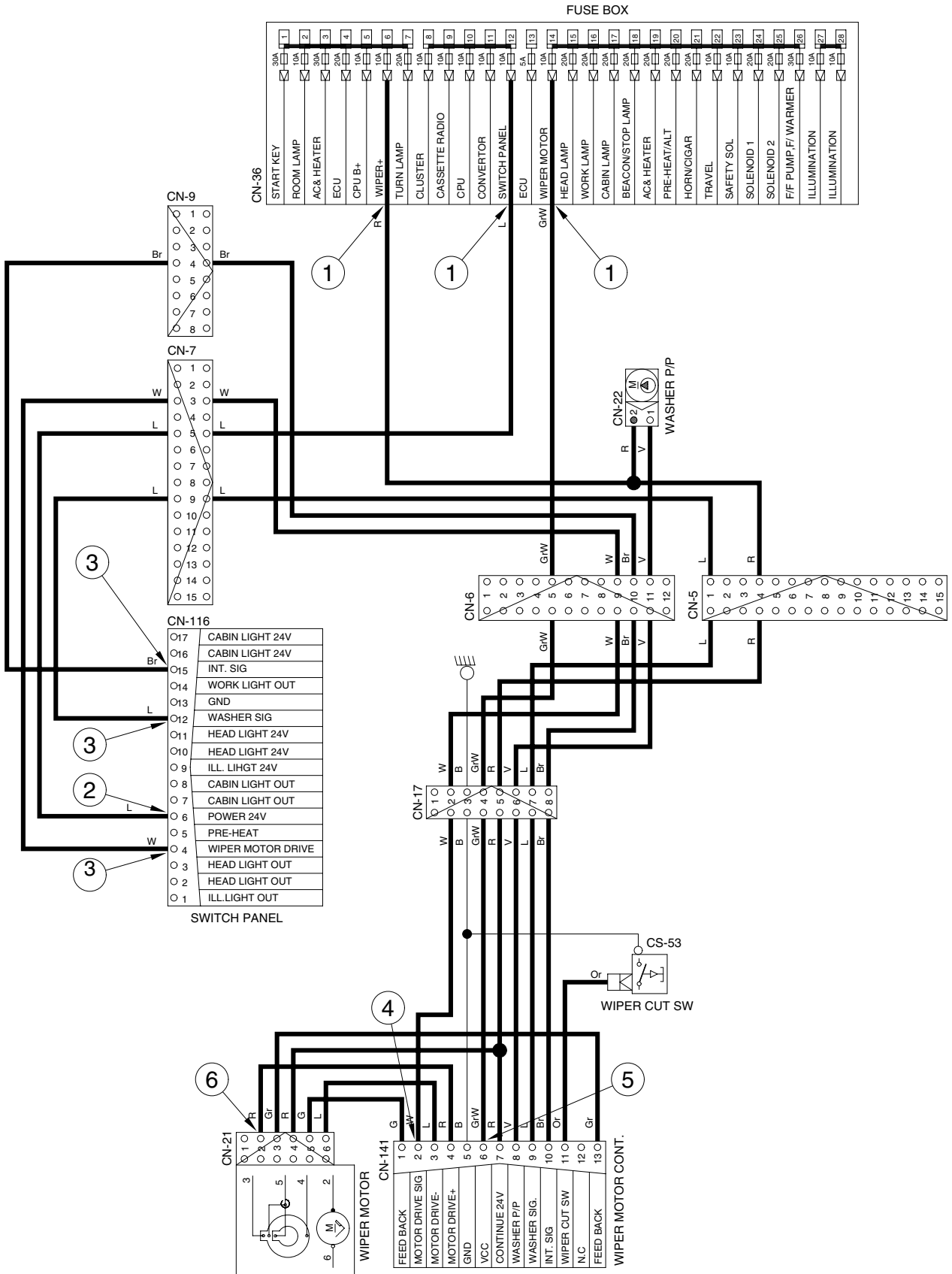

ILLUMINATION CIRCUIT

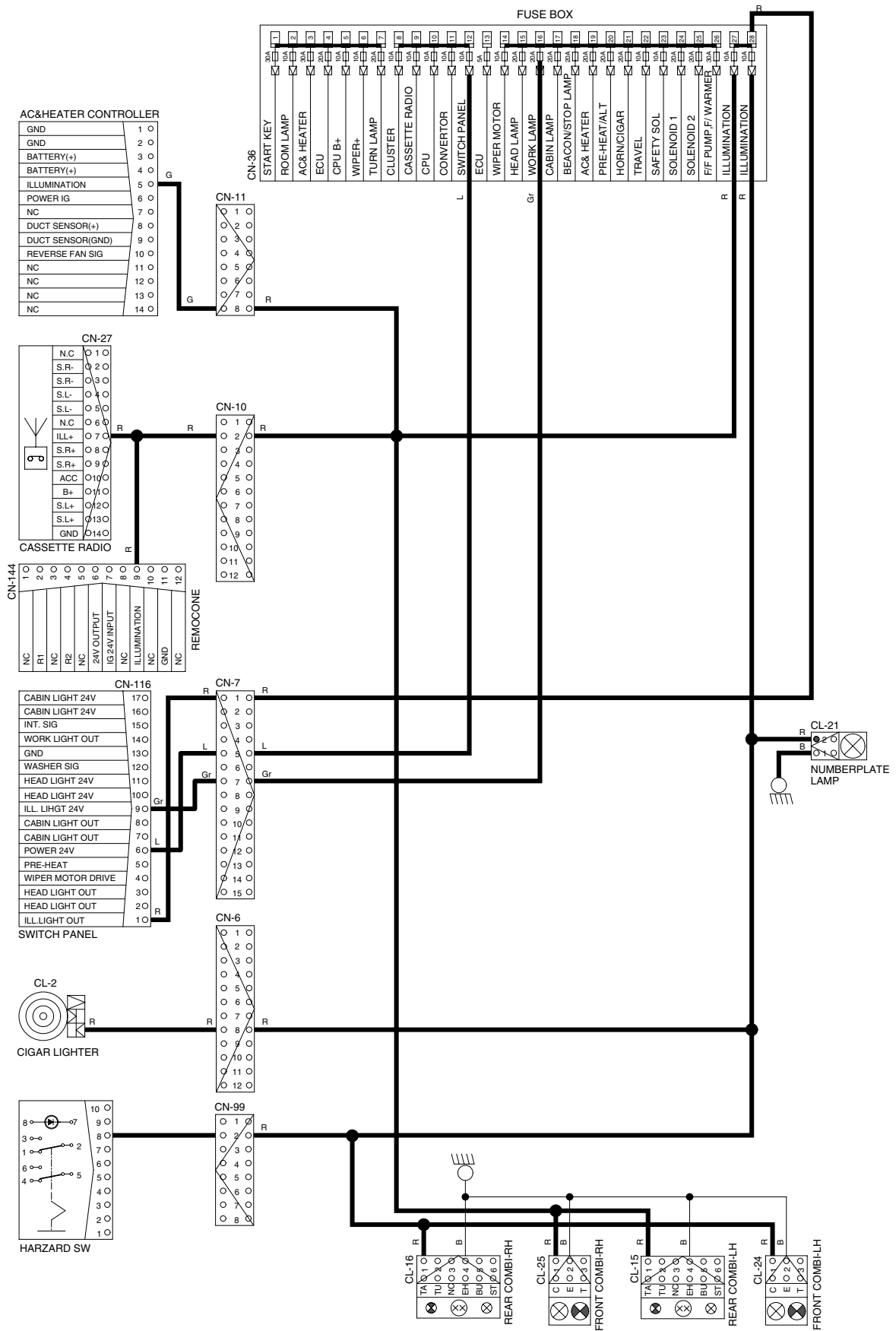

COMBINATION LAMP CIRCUIT

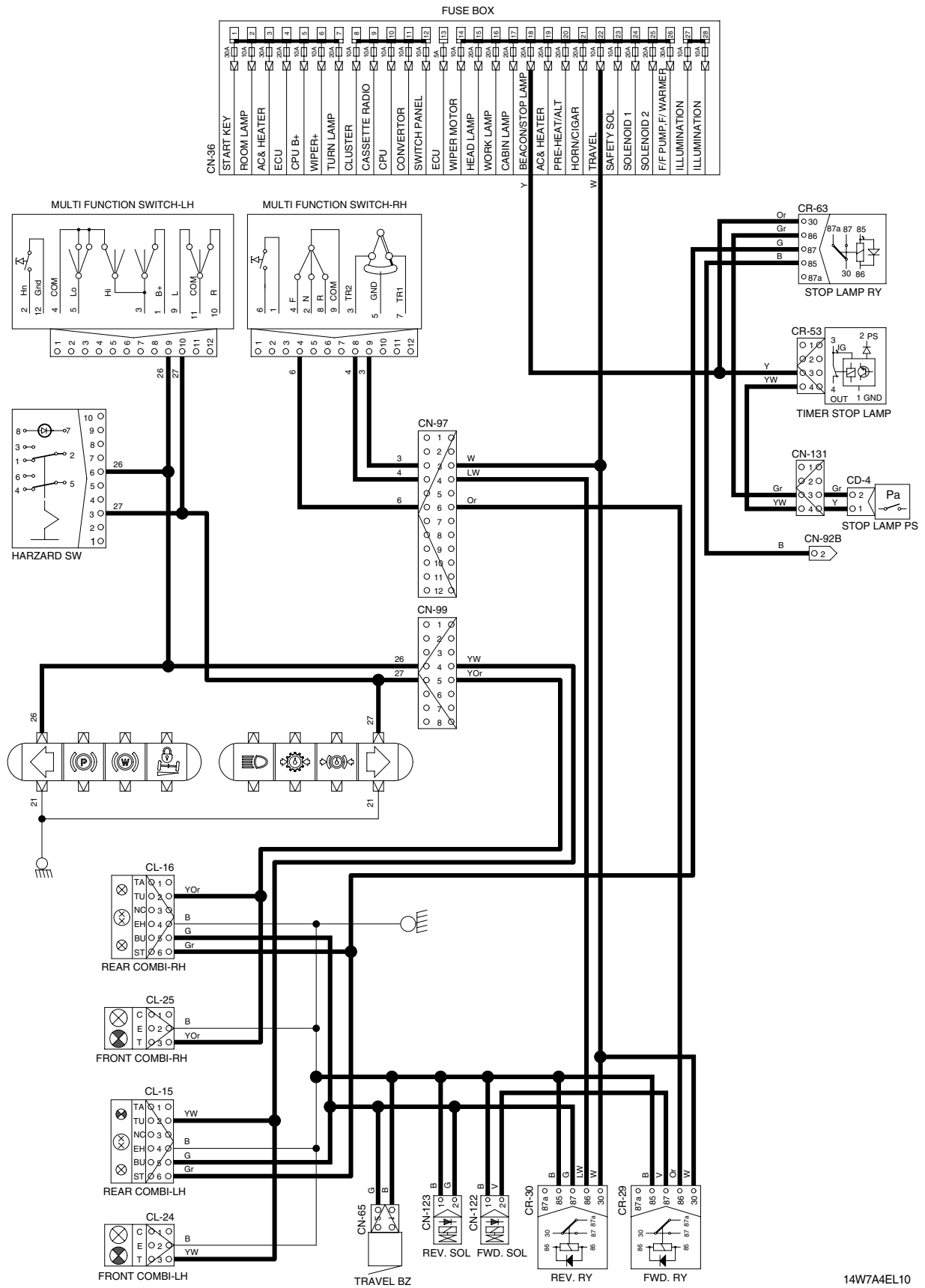

CONTROLLER CIRCUIT

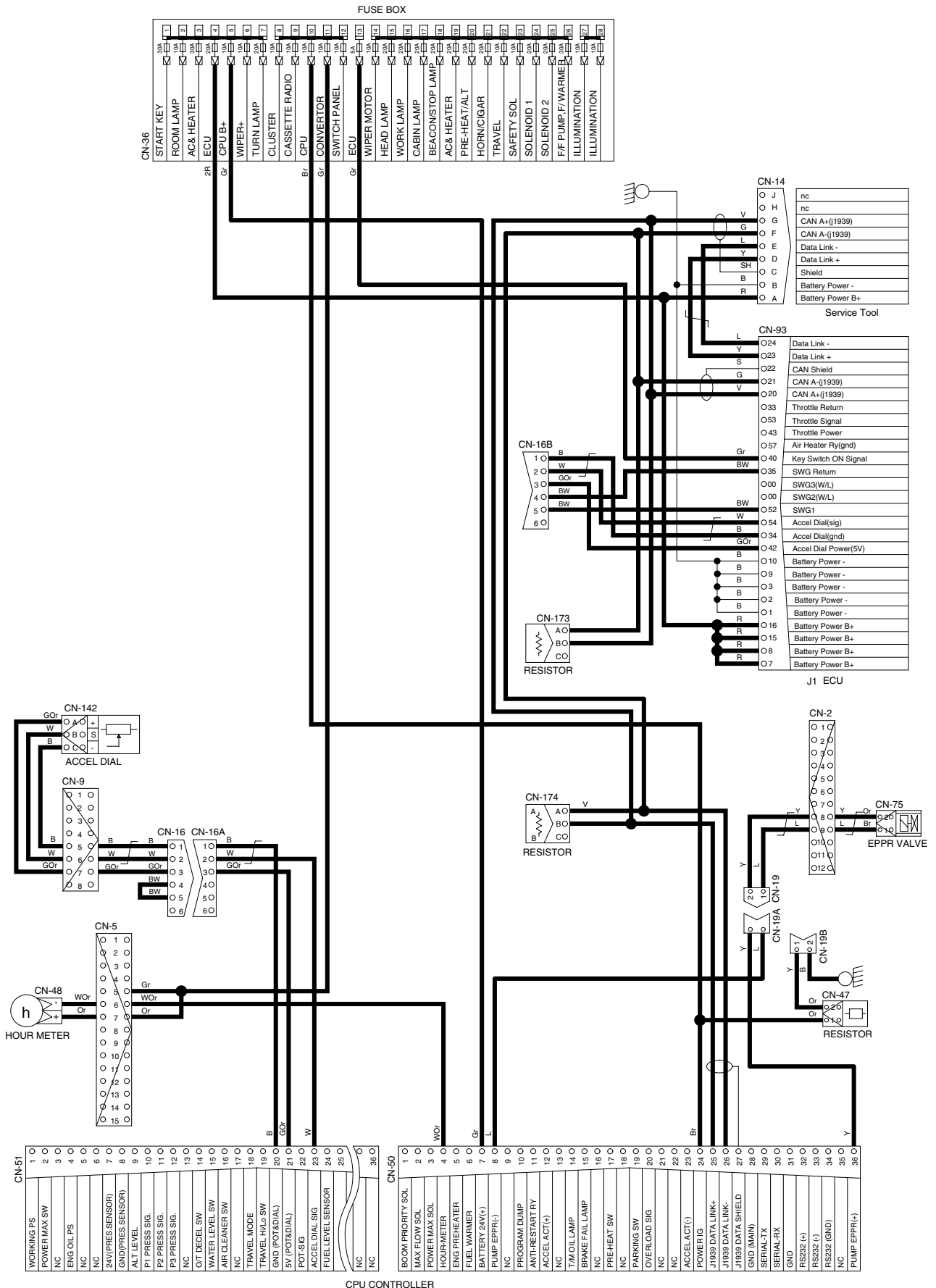

MONITORING CIRCUIT

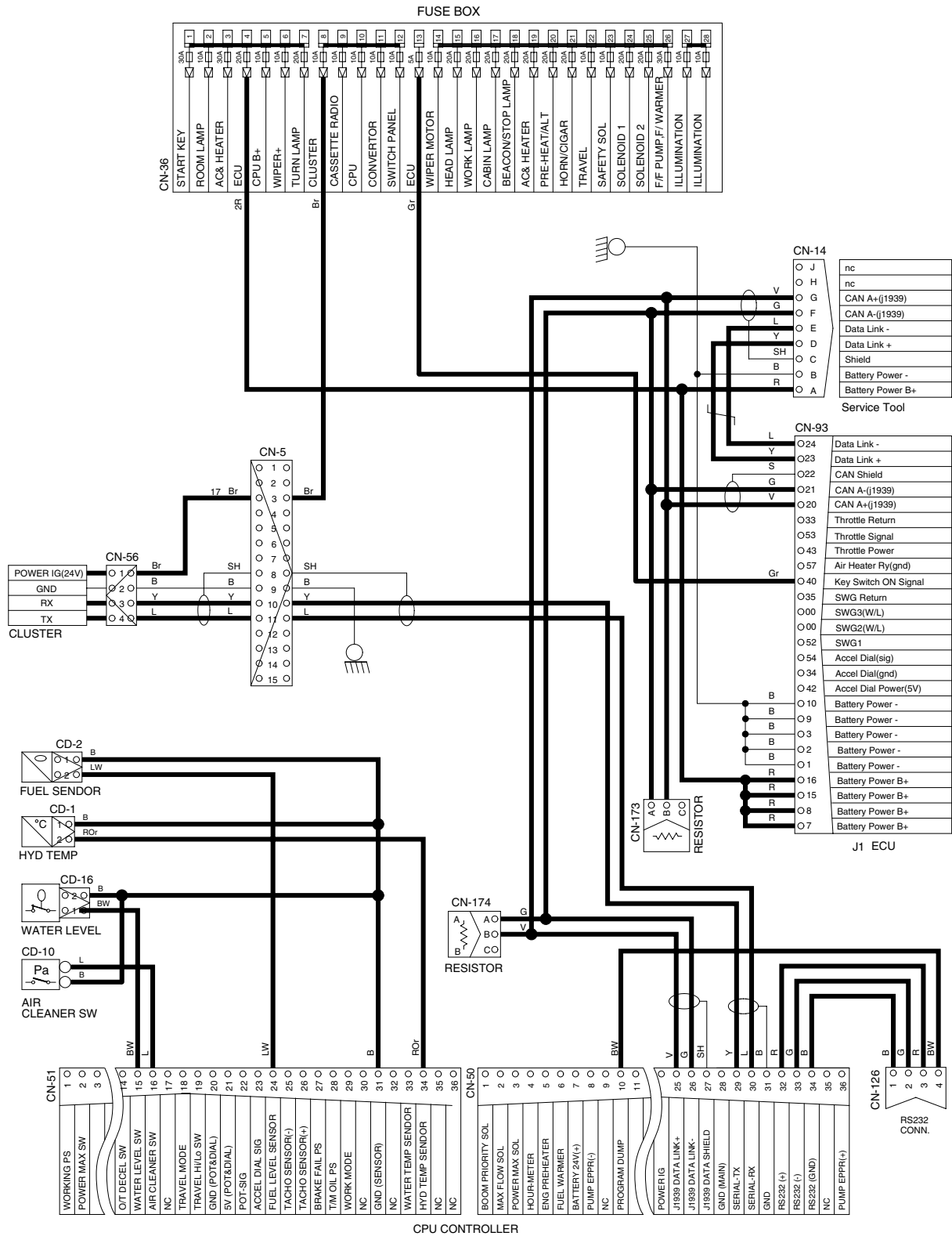

14W7A4EL12

ELECTRIC CIRCUIT FOR HYDRAULIC

