

SPECIFICATIONS

1. MAJOR COMPONENTS

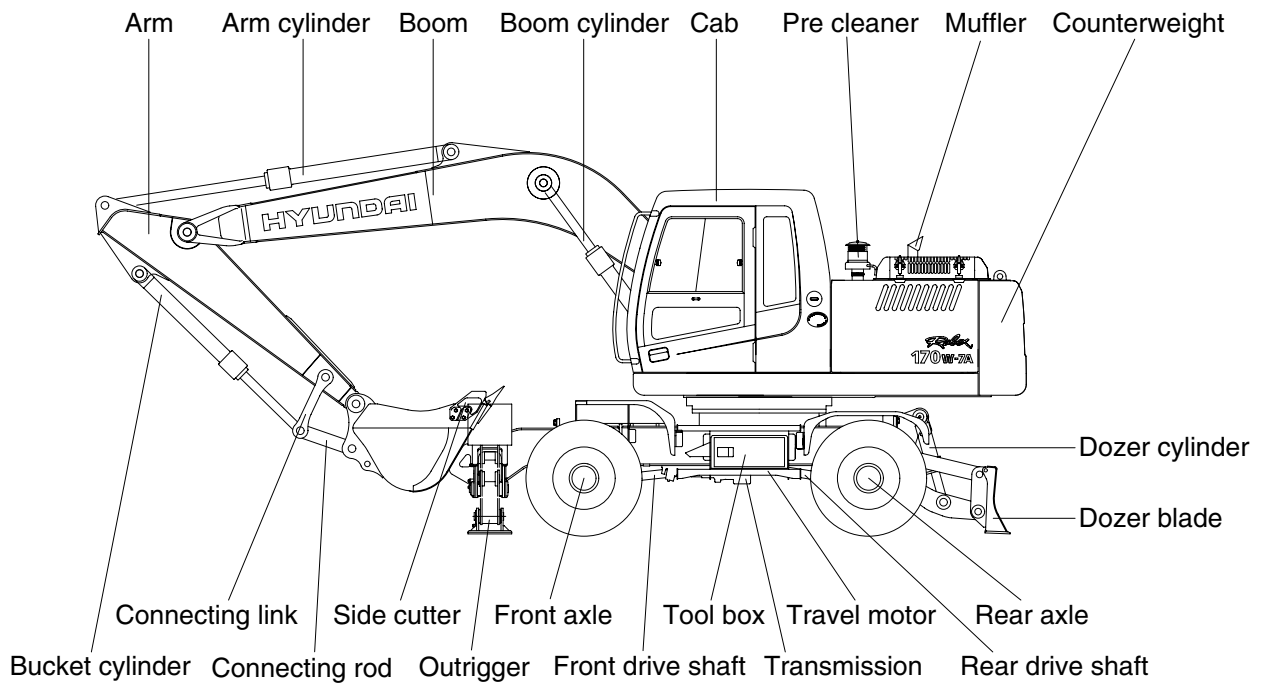
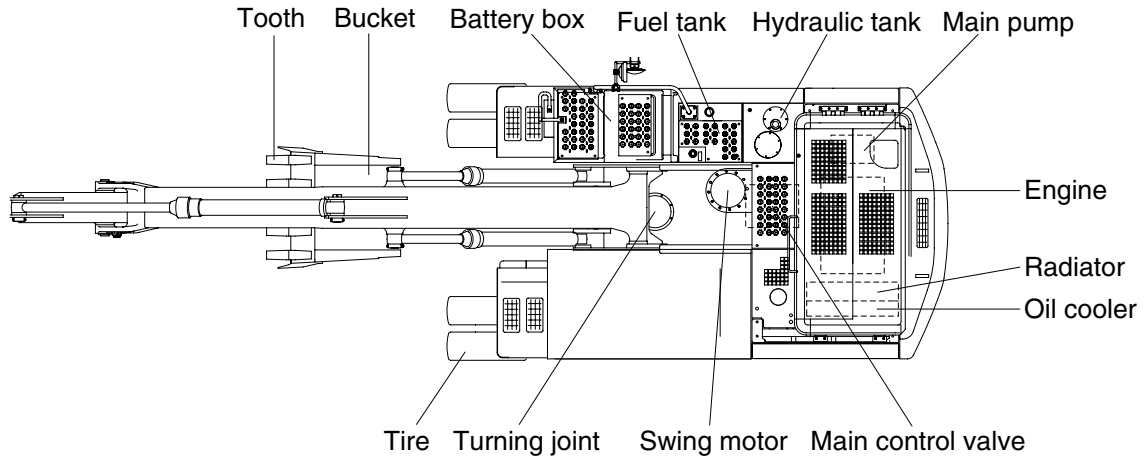

17W7A2SP01

2. SPECIFICATIONS

1) 5.1m(16' 9") ONE PIECE BOOM, 2.2m(7' 3") ARM AND REAR DOZER BLADE

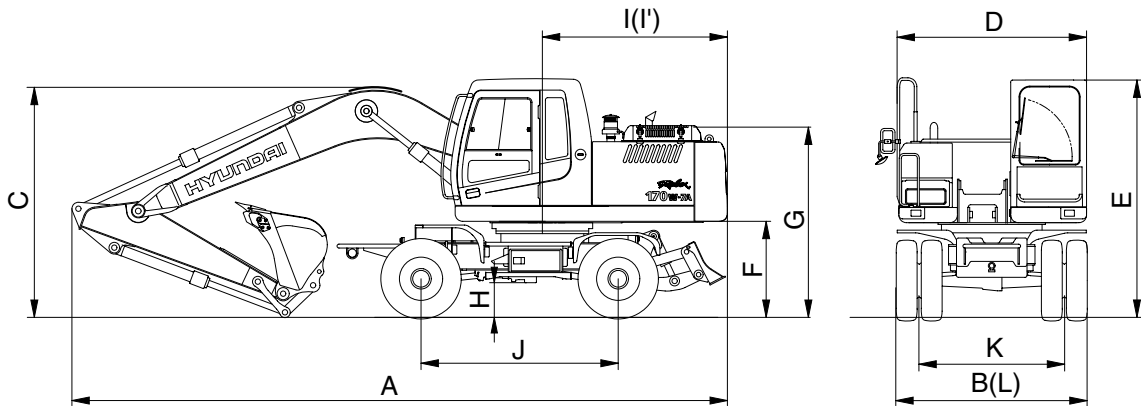

17W7A2SP02

Description		Unit	Specification
Operating weight		kg(lb)	16400(36160)
Bucket capacity(SAE heaped), standard		m ³ (yd ³)	0.76(0.99)
Overall length	A	mm(ft-in)	8610(28' 3")
Overall width	B		2500(8' 2")
Overall height	C		3040(10' 0")
Upperstructure width	D		2475(8' 1")
Cab height	E		3150(10' 4")
Ground clearance of counterweight	F		1270(4' 2")
Engine cover height	G		2532(8' 4")
Minimum ground clearance	H		375(1' 3")
Rear-end distance	I		2480(8' 2")
Rear-end swing radius	I'		2530(8' 4")
Wheel base	J		2600(8' 6")
Tread	K		1914(6' 3")
Dozer blade width	L		2490(8' 2")
Travel speed	Low		km/hr(mph)
	High	30	
Swing speed		rpm	11.5
Gradeability		Degree(%)	30(58)

2) 5.1m(16' 9") HYDRAULIC ADJUSTABLE BOOM, 2.6m(8' 6") ARM AND REAR DOZER BLADE

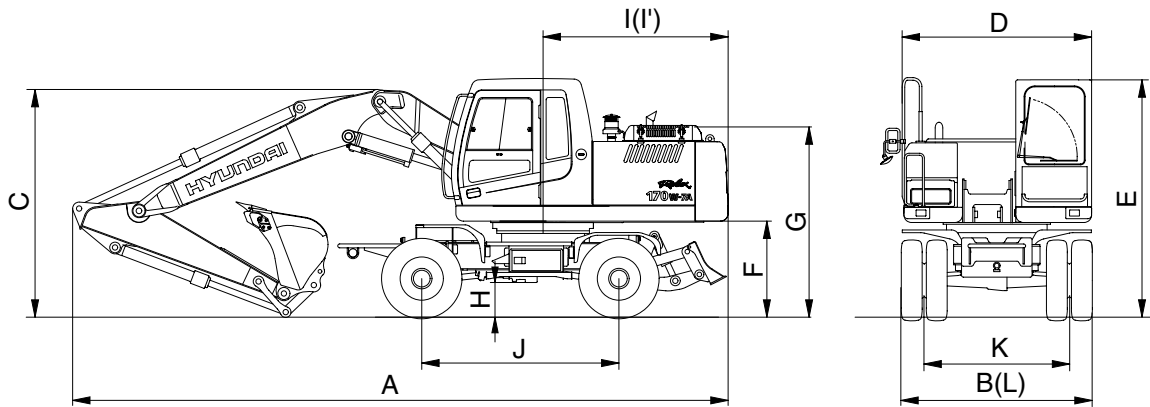

17W7A2SP03

Description		Unit	Specification
Operating weight		kg(lb)	16870(37190)
Bucket capacity(SAE heaped), standard		m ³ (yd ³)	0.76(0.99)
Overall length	A	mm(ft-in)	8750(28' 8")
Overall width	B		2500(8' 2")
Overall height	C		2910(9' 7")
Upperstructure width	D		2475(8' 1")
Cab height	E		3150(10' 4")
Ground clearance of counterweight	F		1270(4' 2")
Engine cover height	G		2532(8' 4")
Minimum ground clearance	H		375(1' 3")
Rear-end distance	I		2480(8' 2")
Rear-end swing radius	I'		2530(8' 4")
Wheel base	J		2600(8' 6")
Tread	K		1914(6' 3")
Dozer blade width	L		2490(8' 2")
Travel speed	Low		km/hr(mph)
	High	30	
Swing speed		rpm	11.5
Gradeability		Degree(%)	30(58)

3. WORKING RANGE

1) 5.1m (16' 9") MONO BOOM

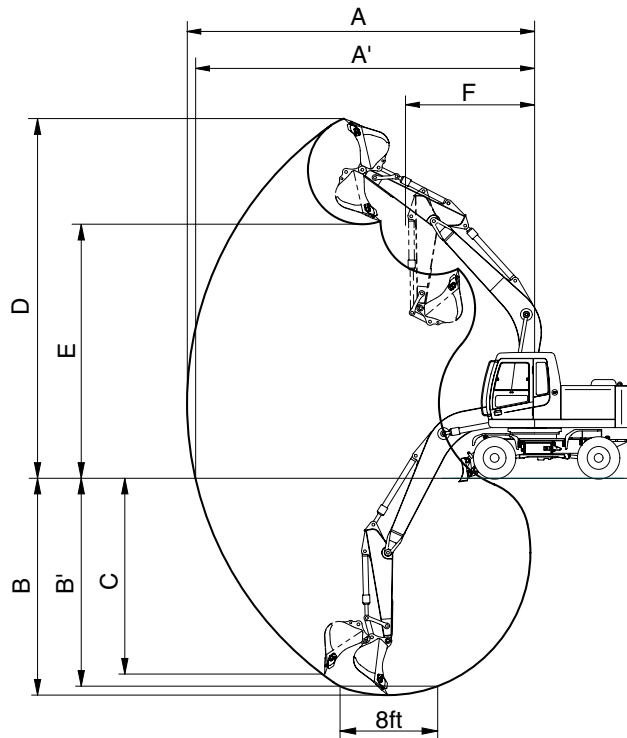

17W72SP05

Description		*2.2m (7' 3") Arm	2.6m (8' 6") Arm	3.1m (10' 2") Arm
Max digging reach	A	8690mm (28' 6")	9030mm (29' 8")	9450mm (31' 0")
Max digging reach on ground	A'	8480mm (27'10")	8820mm (28'11")	9250mm (30' 4")
Max digging depth	B	5420mm (17' 9")	5820mm (19' 1")	6320mm (20' 9")
Max digging depth (8ft level)	B'	5200mm (17' 1")	5610mm (18' 5")	6130mm (20' 1")
Max vertical wall digging depth	C	4890mm (16' 1")	5240mm (17' 2")	5540mm (18' 2")
Max digging height	D	8990mm (29' 6")	9110mm (29'11")	9220mm (30' 3")
Max dumping height	E	6350mm (20'10")	6480mm (21' 3")	6620mm (21' 9")
Min swing radius	F	3180mm (10' 5")	3180mm (10' 5")	3180mm (10' 5")
Bucket digging force	SAE	108.6 [118.4] kN	108.6 [118.4] kN	108.6 [118.4] kN
		11070 [12080] kgf	11070 [12080] kgf	11070 [12080] kgf
		24410 [26630] lbf	24410 [26630] lbf	24410 [26630] lbf
	ISO	124.5 [135.9] kN	124.5 [135.9] kN	124.5 [135.9] kN
		12700 [13850] kgf	12700 [13850] kgf	12700 [13850] kgf
		28000 [30550] lbf	28000 [30550] lbf	28000 [30550] lbf
Arm digging force	SAE	85.2 [93.0] kN	75.0 [81.8] kN	67.4 [73.5] kN
		8690 [9480] kgf	7650 [8350] kgf	6870 [7490] kgf
		19160 [20900] lbf	16870 [18400] lbf	15150 [16530] lbf
	ISO	89.0 [97.1] kN	77.6 [84.6] kN	69.4 [75.7] kN
		9080 [9910] kgf	7910 [8630] kgf	7080 [7720] kgf
		20020 [21840] lbf	17440 [19030] lbf	15610 [17030] lbf

* : Standard [] : Power boost

2) 5.1m (16' 9") HYDRAULIC ADJUSTABLE BOOM

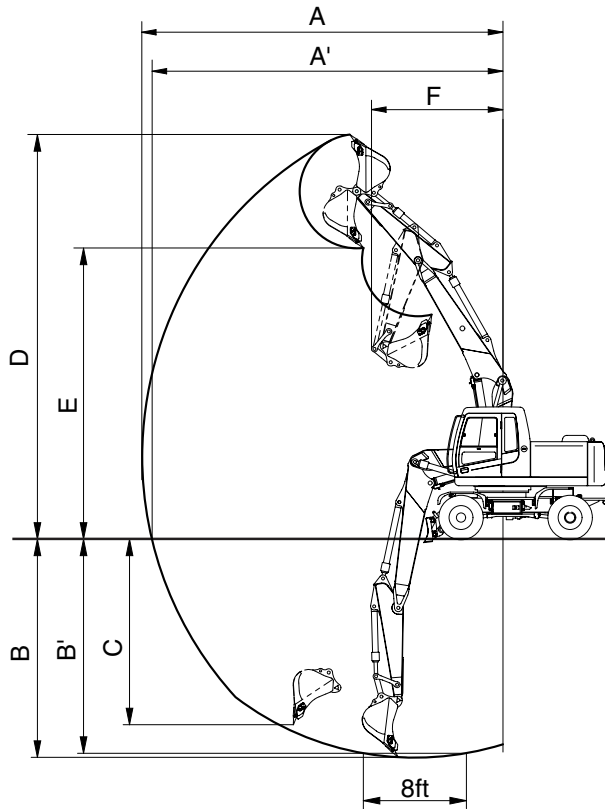

17W72SP06

Description		2.2m (7' 3") Arm	2.6m (8' 6") Arm
Max digging reach	A	8600mm (28' 3")	9120mm (29'11")
Max digging reach on ground	A'	8370mm (27' 6")	8910mm (29' 3")
Max digging depth	B	5220mm (17' 2")	5600mm (18' 4")
Max digging depth (8ft level)	B'	5110mm (16' 9")	5500mm (18' 1")
Max vertical wall digging depth	C	4430mm (14' 6")	4790mm (15' 9")
Max digging height	D	9640mm (31' 8")	9850mm (32' 4")
Max dumping height	E	6930mm (22' 9")	7140mm (23' 5")
Min swing radius	F	3150mm (10' 4")	2970mm (9' 9")
Bucket digging force	SAE	108.6 [118.4] kN	108.6 [118.4] kN
		11070 [12080] kgf	11070 [12080] kgf
		24410 [26630] lbf	24410 [26630] lbf
	ISO	124.5 [135.9] kN	124.5 [135.9] kN
		12700 [13850] kgf	12700 [13850] kgf
		28000 [30550] lbf	28000 [30550] lbf
Arm digging force	SAE	85.2 [93.0] kN	75.0 [81.8] kN
		8690 [9480] kgf	7650 [8350] kgf
		19160 [20900] lbf	16870 [18400] lbf
	ISO	89.0 [97.1] kN	77.6 [84.6] kN
		9080 [9910] kgf	7910 [8630] kgf
		20020 [21840] lbf	17440 [19030] lbf

[] : Power boost

4. WEIGHT











Item	R170W-7A	
	kg	lb
Upperstructure assembly	4490	9900
Main frame weld assembly	1400	3090
Engine assembly	420	930
Main pump assembly	90	200
Main control valve assembly	80	180
Swing motor assembly	250	550
Hydraulic oil tank assembly	180	400
Fuel tank assembly	140	310
Counterweight	2750	6060
Cab assembly	310	680
Lower frame weld assembly	1640	3615
Swing bearing	260	570
Travel motor assembly	60	130
Turning joint	100	220
Transmission assembly	140	310
Front axle assembly	630	1390
Rear axle assembly	540	1190
Dozer blade assembly	830	1830
Front attachment assembly (5.1m boom, 2.2m arm, 0.76m ³ SAE heaped bucket)	2990	6590
5.1m boom assembly	1050	2315
2.2m arm assembly	480	1050
0.76m ³ SAE heaped bucket assembly	570	1260
Boom cylinder assembly	160	350
Arm cylinder assembly	180	400
Bucket cylinder assembly	140	310
Bucket control link assembly	120	265
Oscillating cylinder assembly	30	70
Front outrigger assembly	1020	2250
Rear outrigger assembly	1010	2230
Outrigger cylinder assembly	80	180
Blade cylinder assembly	55	120

5. LIFTING CAPACITIES

1) ROBEX 170W-7A













(1) 5.1m (16' 9") boom, 2.2m (7' 3") arm equipped with 0.76m³(SAE heaped) bucket, rear dozer blade down and 2750kg counterweight.

-  : Rating over-front
-  : Rating over-side or 360 degree













Load point height		Load radius								At max. reach		
		1.5m (5ft)		3.0m (10ft)		4.5m (15ft)		6.0m (20ft)		Capacity		Reach m (ft)
												
7.5m (25ft)	kg lb									*3380 *7450	2920 6440	6.09 (20.0)
6.0m (20ft)	kg lb							*3150 *6940	2870 6330	*3340 *7360	2050 4520	7.32 (24.0)
4.5m (15ft)	kg lb					*4420 *9740	*4420 *9740	*3880 *8550	2820 6220	*3380 *7450	1680 3700	8.01 (26.3)
3.0m (10ft)	kg lb			*9080 *20020	7960 17550	*5600 *12350	4250 9370	*4370 *9630	2670 5890	3390 7470	1510 3330	8.33 (27.3)
1.5m (5ft)	kg lb					*6690 *14750	3910 8620	*4870 *10740	2520 5560	3350 7390	1470 3240	8.32 (27.3)
Ground Line	kg lb			*7220 *15920	7040 15520	*7190 *15850	3720 8200	*5160 *11380	2410 5310	3560 7850	1560 3440	7.99 (26.2)
-1.5m (-5ft)	kg lb	*7210 *15900	*7210 *15900	*10350 *22820	7090 15630	*6990 *15410	3680 8110	*5010 *11050	2380 5250	*3590 *7910	1840 4060	7.28 (23.9)
-3.0m (-10ft)	kg lb	*11320 *24960	*11320 *24960	*8600 *18960	7270 16030	*5960 *13140	3760 8290			*3290 *7250	2570 5670	6.02 (19.8)

- Note
1. Lifting capacity are based on SAE J1097 and ISO 10567.
 2. Lifting capacity of the ROBEX series does not exceed 75% of tipping load with the machine on firm, level ground or 87% of full hydraulic capacity.
 3. The load point is a hook located on the back of the bucket.
 4. *indicates load limited by hydraulic capacity.













(2) 5.1m (16' 9") boom, 2.6m (8' 6") arm equipped with 0.76m³ (SAE heaped) bucket, rear dozer blade down and 2750kg counterweight.

Load point height		Load radius										At max. reach		
		1.5m (5ft)		3.0m (10ft)		4.5m (15ft)		6.0m (20ft)		7.5m (25ft)		Capacity		Reach
														m (ft)
7.5m (25ft)	kg lb											*3070 *6770	2560 5640	6.58 (21.6)
6.0m (20ft)	kg lb							*2980 *6570	2920 6440			*3070 *6770	1860 4100	7.71 (25.3)
4.5m (15ft)	kg lb							*3570 *7870	2830 6240			*3130 *6900	1530 3370	8.36 (27.4)
3.0m (10ft)	kg lb			*7970 *17570	*7970 *17570	*5150 *11350	4290 9460	*4090 *9020	2670 5890	*2730 *6020	1780 3920	3150 6940	1380 3040	8.67 (28.4)
1.5m (5ft)	kg lb			*7190 *15850	*7190 *15850	*6360 *14020	3920 8640	*4660 *10270	2500 5510	*3400 *7500	1700 3750	3110 6860	1340 2950	8.66 (28.4)
Ground Line	kg lb			*7730 *17040	6980 15390	*7040 *15520	3690 8140	*5040 *11110	2370 5220	*2960 *6530	1650 3640	3280 7230	1410 3110	8.34 (27.4)
-1.5m (-5ft)	kg lb	*6760 *14900	*6760 *14900	*10570 *23300	6970 15370	*7050 *15540	3610 7960	*5040 *11110	2320 5110			*3450 *7610	1630 3590	7.67 (25.2)
-3.0m (-10ft)	kg lb	*9900 *21830	*9900 *21830	*9260 *20410	7110 15670	*6290 *13870	3650 8050	*4320 *9520	2360 5200			*3320 *7320	2200 4850	6.51 (21.4)
-4.5m (-15ft)	kg lb			*6310 *13910	*6310 *13910									













(3) 5.1m (16' 9") boom, 3.1m (11' 1") arm equipped with 0.76m³ (SAE heaped) bucket, rear dozer blade down and 2750kg counterweight.

Load point height		Load radius										At max. reach		
		1.5m (5ft)		3.0m (10ft)		4.5m (15ft)		6.0m (20ft)		7.5m (25ft)		Capacity		Reach
														m (ft)
7.5m (25ft)	kg lb											*2730 *6020	2210 4870	7.15 (23.5)
6.0m (20ft)	kg lb							*2750 *6060	*2750 *6060			*2770 *6110	1640 3620	8.19 (26.9)
4.5m (15ft)	kg lb							*3180 *7010	2860 6310	*2120 *4670	1850 4080	*2840 *6260	1370 3020	8.80 (28.9)
3.0m (10ft)	kg lb			*6670 *14700	*6670 *14700	*4600 *10140	4380 9660	*3750 *8270	2690 5930	*2970 *6550	1780 3920	2890 6370	1230 2710	9.09 (29.8)
1.5m (5ft)	kg lb			*9920 *21870	7470 16470	*5920 *13050	3960 8730	*4380 *9660	2500 5510	*3610 *7960	1680 3700	2850 6280	1190 2620	9.08 (29.8)
Ground Line	kg lb	*4120 *9080	*4120 *9080	*8310 *18320	6970 15370	*6810 *15010	3680 8110	*4870 *10740	2340 5160	3800 8380	1610 3550	2980 6570	1240 2730	8.78 (28.8)
-1.5m (-5ft)	kg lb	*6330 *13960	*6330 *13960	*10140 *22350	6870 15150	*7040 *15520	3550 7830	*5020 *11070	2260 4980			*3270 *7210	1420 3130	8.15 (26.7)
-3.0m (-10ft)	kg lb	*8880 *19580	*8880 *19580	*9900 *21830	6950 15320	*6570 *14480	3550 7830	*4630 *10210	2270 5000			*3280 *7230	1840 4060	7.09 (23.3)
-4.5m (-15ft)	kg lb	*12300 *27120	*12300 *27120	*7530 *16600	7210 15900	*5010 *11050	3700 8160							

(4) 5.1m (16' 9") hydraulic adjustable boom, 2.2m (7' 3") arm equipped with 0.76m³ (SAE heaped) bucket, rear dozer blade down and 2750kg counterweight.

Load point height		Load radius										At max. reach				
		1.5m (5ft)		3.0m (10ft)		4.5m (15ft)		6.0m (20ft)		7.5m (25ft)		Capacity		Reach		
														m (ft)		
6.0m (20ft)	kg lb												*3390 *7470	1990 4390	7.39 (24.2)	
4.5m (15ft)	kg lb							*3920 *8640	2810 6190				*3370 *7430	1620 3570	8.08 (26.5)	
3.0m (10ft)	kg lb					*5630 *12410	4240 9350	*4370 *9630	2660 5860				3370 7430	1460 3220	8.39 (27.5)	
1.5m (5ft)	kg lb					*6640 *14640	3870 8530	*4830 *10650	2490 5490	*3240 *7140	1700 3750			3340 7360	1430 3150	8.38 (27.5)
Ground Line	kg lb			*6390 *14090	*6390 *14090	*7070 *15590	3670 8090	*5070 *11180	2380 5250				*3430 *7560	1520 3350	8.05 (26.4)	
-1.5m (-5ft)	kg lb	*6490 *14310	*6490 *14310	*10000 *22050	7040 15520	*6810 *15010	3640 8020	*4870 *10740	2350 5180				*3310 *7300	1800 3970	7.35 (24.1)	
-3.0m (-10ft)	kg lb			*8110 *17880	7250 15980	*5680 *12520	3740 8250						*2800 *6170	2520 5560	6.11 (20.0)	

(5) 5.1m (16' 9") hydraulic adjustable boom, 2.6m (8' 6") arm equipped with 0.76m³ (SAE heaped) bucket, rear dozer blade down and 2750kg counterweight.

Load point height		Load radius										At max. reach				
		1.5m (5ft)		3.0m (10ft)		4.5m (15ft)		6.0m (20ft)		7.5m (25ft)		Capacity		Reach		
														m (ft)		
6.0m (20ft)	kg lb													*3120 *6880	1790 3950	7.81 (25.6)
4.5m (15ft)	kg lb													*3120 *6880	1470 3240	8.45 (27.7)
3.0m (10ft)	kg lb							*4110 *9060	2660 5860	*3100 *6830	1760 3880			3120 6880	1330 2930	8.75 (28.7)
1.5m (5ft)	kg lb			*6240 *13760	*6240 *13760	*6330 *13960	3890 8580	*4630 *10210	2480 5470	*3760 *8290	1680 3700			3090 6810	1290 2840	8.74 (28.7)
Ground Line	kg lb			*6970 *15370	6900 15210	*6940 *15300	3640 8020	*4970 *10960	2340 5160	*3510 *7740	1620 3570			*3240 *7140	1370 3020	8.43 (27.7)
-1.5m (-5ft)	kg lb	*6170 *13600	*6170 *13600	*9940 *21910	6910 15230	*6880 *15170	3570 7870	*4920 *10850	2290 5050					*3190 *7030	1590 3510	7.77 (25.5)
-3.0m (-10ft)	kg lb	*9510 *20970	*9510 *20970	*8830 *19470	7080 15610	*6040 *13320	3630 8000	*4120 *9080	2350 5180					*2890 *6370	2140 4720	6.63 (21.8)
-4.5m (-15ft)	kg lb			*5650 *12460	*5650 *12460	*3580 *7890	*3580 *7890									

6. BUCKET SELECTION GUIDE

1) GENERAL BUCKET

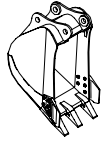
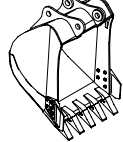
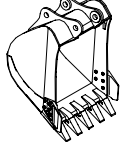
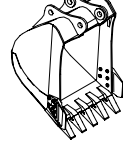
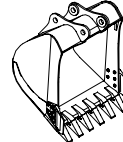
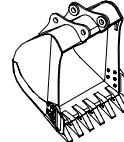
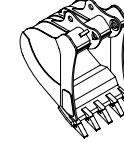
						
0.39m ³ SAE heaped bucket	0.50m ³ SAE heaped bucket	0.64m ³ SAE heaped bucket	※0.76m ³ SAE heaped bucket	0.89m ³ SAE heaped bucket	1.05m ³ SAE heaped bucket	◆0.69m ³ SAE heaped bucket

Capacity		Width		Weight	Recommendation				
					5.1m (16' 9") Mono boom			5.1m (16' 9") Hyd adjustable boom	
SAE heaped	CECE heaped	Without side cutter	With side cutter		2.0m arm (7' 3")	2.6m arm (8' 6")	3.1m arm (10' 2")	2.2m arm (7' 3")	2.6m arm (8' 6")
0.39m ³ (0.51yd ³)	0.34m ³ (0.44yd ³)	620mm (24.4")	740mm (29.1")	410kg (900lb)					
0.50m ³ (0.65yd ³)	0.44m ³ (0.58yd ³)	760mm (29.9")	880mm (34.6")	470kg (1040lb)					
0.64m ³ (0.84yd ³)	0.55m ³ (0.72yd ³)	920mm (36.2")	1040mm (40.9")	510kg (1120lb)					
※0.76m ³ (0.99yd ³)	0.65m ³ (0.85yd ³)	1060mm (41.7")	1180mm (46.5")	570kg (1260lb)					
0.89m ³ (1.16yd ³)	0.77m ³ (1.01yd ³)	1220mm (48.0")	1340mm (52.8")	610kg (1340lb)					
1.05m ³ (1.37yd ³)	0.90m ³ (1.18yd ³)	1400mm (55.1")	1520mm (59.8")	680kg (1500lb)					
◆0.69m ³ (0.9yd ³)	0.62m ³ (0.81yd ³)	990mm (39.0")	-	700kg (1540lb)					

※ : Standard bucket

◆ : Heavy duty bucket

 Applicable for materials with density of 2000kg/m³ (3370lb/yd³) or less

 Applicable for materials with density of 1600kg/m³ (2700lb/yd³) or less

 Applicable for materials with density of 1100kg/m³ (1850lb/yd³) or less

7. SPECIFICATIONS FOR MAJOR COMPONENTS

1) ENGINE

Item	Specification
Model	Mitsubishi D04FD-TAA
Type	4-cycle turbocharged charge air cooled diesel engine
Cooling method	Water cooling
Number of cylinders and arrangement	4 cylinders, in-line
Firing order	1-3-4-2
Combustion chamber type	Direct injection type
Cylinder bore × stroke	102 × 130mm (4.02" × 5.12")
Piston displacement	4249cc (259cu in)
Compression ratio	16.5 : 1
Rated gross horse power(SAE J1995)	126Hp at 2000rpm (94kW at 2000rpm)
Maximum torque at 1800rpm	47.7kgf · m (345lbf · ft)
Engine oil quantity	18.5 l (4.9U.S. gal)
Dry weight	420kg (926lb)
High idling speed	2100 ± 50rpm
Low idling speed	800 ± 100rpm
Rated fuel consumption	170.6g/Hp · hr at 2000rpm
Starting motor	Mitsubishi 24V-5.0kW
Alternator	Mitsubishi 24V-50A
Battery	2 × 12V × 100Ah

2) MAIN PUMP

Item	Specification
Type	Variable displacement tandem axis piston pumps
Capacity	2 × 80cc/rev
Maximum pressure	330kgf/cm ² (4694psi) [360kgf/cm ² (5120psi)]
Rated oil flow	2 × 168 l /min (44.4U.S. gpm/ 37.0U.K. gpm)
Rated speed	2100rpm

[]: Poer boost

3) GEAR PUMP

Item	Specification
Type	Fixed displacement gear pump single stage
Capacity	15cc/rev
Maximum pressure	40kgf/cm ² (570psi)
Rated oil flow	31.5 l /min (8.3U.S. gpm/6.9U.K. gpm)

4) MAIN CONTROL VALVE

Item	Specification
Type	11 spools two-block
Operating method	Hydraulic pilot system
Main relief valve pressure	330kgf/cm ² (4695psi) [360kgf/cm ² (5120psi)]
Overload relief valve pressure	380kgf/cm ² (5400psi)

[]: Poer boost

5) SWING MOTOR

Item	Specification
Type	Fixed displacement axial piston motor
Capacity	117.8cc/rev
Relief pressure	240kgf/cm ² (3414psi)
Braking system	Automatic, spring applied hydraulic released
Braking torque	56kgf · m (405lbf · ft)
Brake release pressure	20kgf/cm ² (284psi)
Reduction gear type	2 - stage planetary

6) TRAVEL MOTOR

Item	Specification
Type	Variable displacement bent-axis axial piston motor
Relief pressure	360kgf/cm ² (5120psi)
Counter balance valve	Applied
Capacity (Max/min)	160/65cc/rev

7) POWER TRAIN

Item	Description	Specification	
Transmission	Type	2 speed power shift transmission	
	Gear ratio	1st	4.87
		2nd	1.20
Parking brake	Type	Multi disc brake integrated in transmission	
	Maximum braking power	3044kgf · m (22020lb · ft)	
Axle	Type	4 wheel drive with differential	
	Gear ratio	22.11	
	Brake	Multi disc brake	

8) REMOTE CONTROL VALVE

Item	Specification	
Type	Pressure reducing type	
Operating pressure	Minimum	6.5kg/cm ² (92psi)
	Maximum	26kg/cm ² (370psi)
Single operation stroke	Lever	61mm (2.4in)

9) CYLINDER

Item	Specification	
Boom cylinder	Bore dia × Rod dia × Stroke	∅ 115 × ∅ 80 × 1090mm
	Cushion	Extend only
Arm cylinder	Bore dia × Rod dia × Stroke	∅ 120 × ∅ 85 × 1340mm
	Cushion	Extend and retract
Bucket cylinder	Bore dia × Rod dia × Stroke	∅ 115 × ∅ 80 × 950mm
	Cushion	Extend only
Dozer cylinder	Bore dia × Rod dia × Stroke	∅ 110 × ∅ 75 × 235mm
	Cushion	Extend only
Outrigger cylinder	Bore dia × Rod dia × Stroke	∅ 125 × ∅ 75 × 475mm
	Cushion	-
2 Piece boom Adjust cylinder	Bore dia × Rod dia × Stroke	∅ 160 × ∅ 95 × 650mm
	Cushion	Extend only

10) BUCKET

Item	Capacity		Tooth quantity	Width	
	SAE heaped	CECE heaped		Without side cutter	With side cutter
Standard	0.76m ³ (0.99yd ³)	0.65m ³ (0.85yd ³)	5	1060mm (41.7")	1180mm (46.5")
Option	0.39m ³ (0.51yd ³)	0.34m ³ (0.44yd ³)	3	620mm (24.4")	740mm (29.1")
	0.50m ³ (0.65yd ³)	0.44m ³ (0.58yd ³)	4	760mm (29.9")	880mm (34.6")
	0.64m ³ (0.84yd ³)	0.55m ³ (0.72yd ³)	5	920mm (36.2")	1040mm (40.9")
	0.89m ³ (1.16yd ³)	0.77m ³ (0.85yd ³)	6	1220mm (48.0")	1340mm (52.8")
	1.05m ³ (1.37yd ³)	0.90m ³ (1.01yd ³)	6	1400mm (55.1")	1520mm (59.8")
	◆ 0.69m ³ (0.9yd ³)	0.62m ³ (0.81yd ³)	5	990mm (39.0")	-

◆: Heavy duty bucket

8. RECOMMENDED OILS

Use only oils listed below or equivalent.
Do not mix different brand oil.

Service point	Kind of fluid	Capacity l (U.S. gal)	Ambient temperature °C(°F)							
			-20 (-4)	-10 (14)	0 (32)	10 (50)	20 (68)	30 (86)	40 (104)	
Engine oil pan	Engine oil	18.5 (4.9)					SAE 30			
Transmission case			3.0 (0.8)	SAE 10W						
		SAE 10W-30								
Swing drive	Gear oil	5.0 (1.3)					SAE 85W-140			
	Grease	1.2 (0.3)	NLGI NO.1							
							NLGI NO.2			
Front axle	Gear oil	Center : 10.5 (2.8) Hub : 2.5×2 (0.7×2)					SAE 85W-90			
Rear axle		Center : 15.1 (4.0) Hub : 2.5×2 (0.7×2)								
Hydraulic tank	Hydraulic oil	Tank: 160 (42.3) System: 270 (71.3)	ISO VG 32							
							ISO VG 46			
							ISO VG 68			
Fuel tank	Diesel fuel	260 (68.7)	ASTM D975 NO.1							
							ASTM D975 NO.2			
Fitting (Grease nipple)	Grease	As required	NLGI NO.1							
							NLGI NO.2			
Radiator (Reservoir tank)	Mixture of antifreeze and water 50 : 50	30 (7.9)					Ethylene glycol base permanent type			

SAE : Society of Automotive Engineers
API : American Petroleum Institute
ISO : International Organization for Standardization
NLGI : National Lubricating Grease Institute
ASTM : American Society of Testing and Material