

GROUP 4 HYDRAULIC SYSTEM

HYDRAULIC COMPONENTS MOUNTING 1

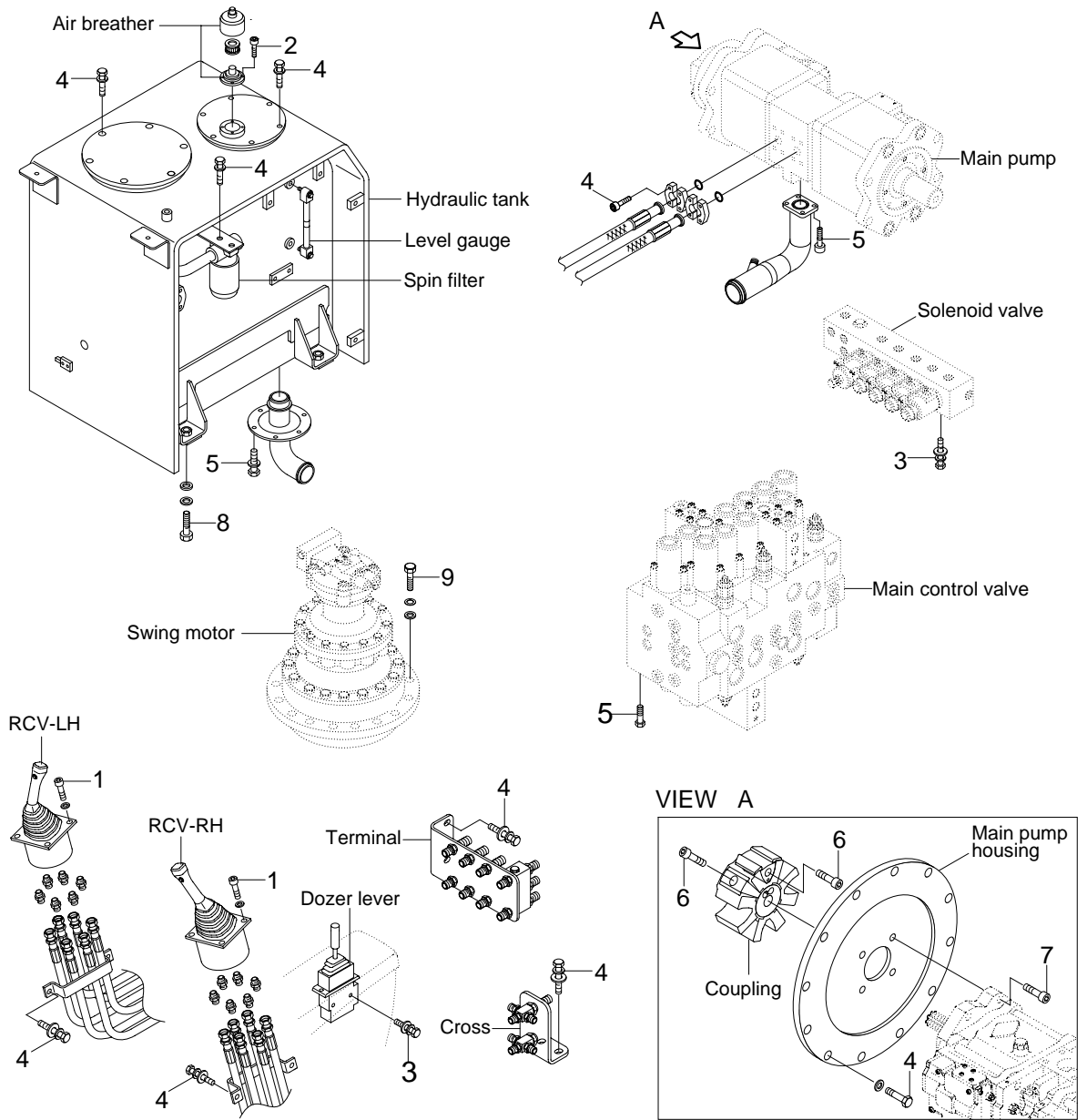

17W79CM05

· Tightening torque

Item	Size	kgf · m	lbf · ft
1	M 6 × 1.0	1.05 ± 0.2	7.6 ± 1.45
2	M 6 × 1.0	1.44 ± 0.3	10.4 ± 2.2
3	M 8 × 1.25	2.5 ± 0.5	18.1 ± 3.6
4	M 10 × 1.5	6.9 ± 1.4	49.9 ± 10.1
5	M 12 × 1.75	12.2 ± 1.3	88.2 ± 9.4

Item	Size	kgf · m	lbf · ft
6	M 16 × 2.0	22.0 ± 1.0	159 ± 7.2
7	M 16 × 2.0	22.1 ± 2.4	160 ± 17.4
8	M 20 × 2.5	45.0 ± 5.1	325 ± 36.9
9	M 20 × 2.5	57.9 ± 8.7	419 ± 62.9
-	-	-	-

HYDRAULIC COMPONENTS MOUNTING 2

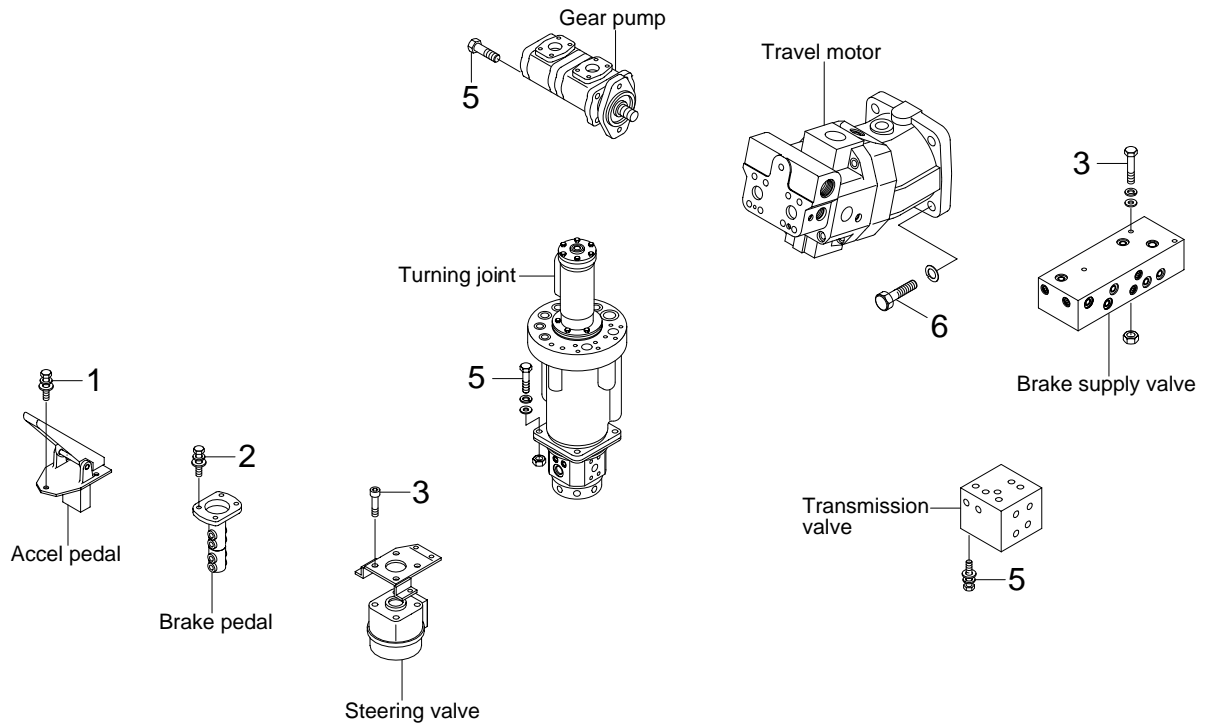

Boom safety lock system

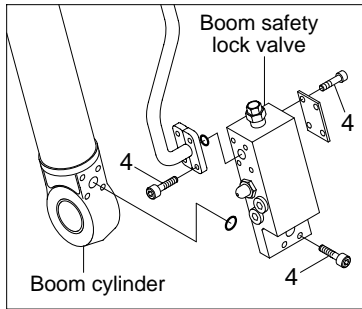

Arm safety lock system

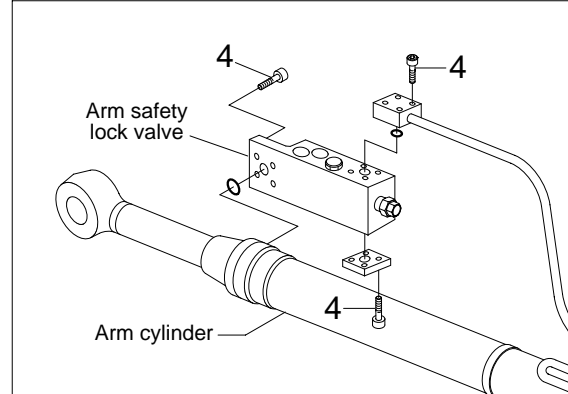

17W79CM06

· Tightening torque

Item	Size	kgf · m	lbf · ft
1	M 6 × 1.0	1.05 ± 0.2	7.6 ± 1.4
2	M 8 × 1.25	2.5 ± 0.5	18.1 ± 3.6
3	M10 × 1.5	6.9 ± 1.4	49.9 ± 10.1

Item	Size	kgf · m	lbf · ft
4	M10 × 1.5	8.27 ± 1.7	59.8 ± 12.3
5	M12 × 1.75	12.0 ± 1.3	86.8 ± 9.4
6	M16 × 2.0	29.6 ± 3.2	214 ± 23.1

HYDRAULIC COMPONENTS MOUNTING 3

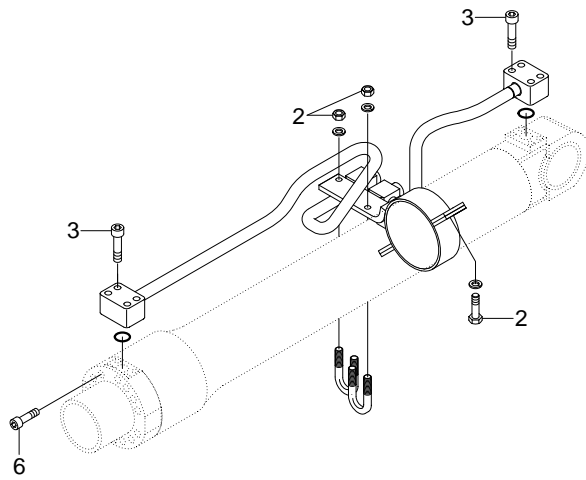

BOOM CYLINDER

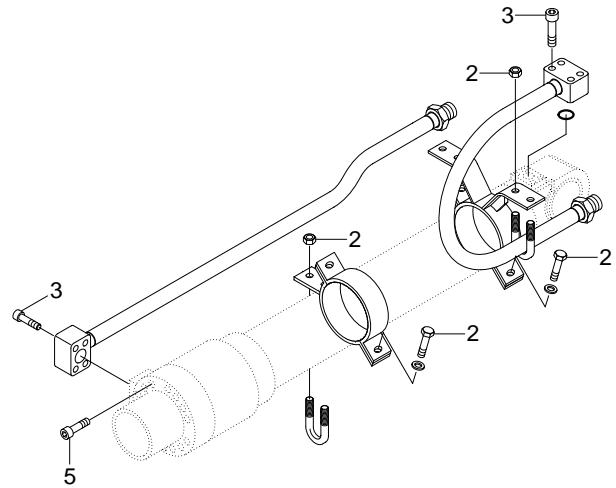

ARM CYLINDER

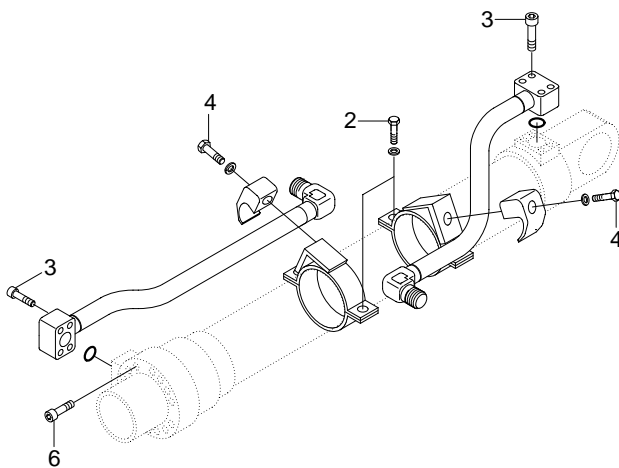

BUCKET CYLINDER

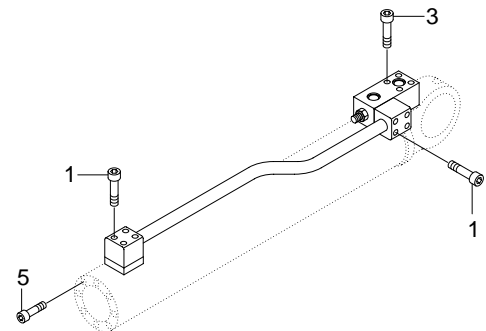

DOZER & OUTRIGGER CYLINDER

17W79CM07

· Tightening torque

Item	Size	kgf · m	lbf · ft
1	M8 × 1.25	2.7 ± 0.3	19.5 ± 2.2
2	M10 × 1.5	3.2 ± 0.3	23.1 ± 2.2
3	M10 × 1.5	5.4 ± 0.5	39.1 ± 3.6

Item	Size	kgf · m	lbf · ft
4	M12 × 1.75	5.5 ± 0.6	39.8 ± 4.3
5	M16 × 2.0	23 ± 2.0	166 ± 14.5
6	M18 × 2.5	32 ± 3.0	232 ± 21.7