

GROUP 4 MAIN CONTROL VALVE

1. REMOVAL AND INSTALL OF MOTOR

1) REMOVAL

- (1) Lower the work equipment to the ground and stop the engine.
- (2) Operate the control levers and pedals several times to release the remaining pressure in the hydraulic piping.
- (3) Loosen the breather slowly to release the pressure inside the hydraulic tank.
▲ Escaping fluid under pressure can penetrate the skin causing serious injury. When pipes and hoses are disconnected, the oil inside the piping will flow out, so catch it in oil pan.
- (4) Remove bolts and disconnect pipe.
- (5) Disconnect pilot line hoses.
- (6) Disconnect pilot piping.
- (7) Sling the control valve assembly and remove the control valve mounting bolt.
· Weight : 80kg(180lb)
- (8) Remove the control valve assembly.
When removing the control valve assembly, check that all the piping have been disconnected.

2) INSTALL

- (1) Carry out installation in the reverse order to removal.
- (2) Bleed the air from below items.
Cylinder(Boom, arm, bucket)
Swing motor
Travel motor
See each item removal and install.
- (3) Confirm the hydraulic oil level and recheck the hydraulic oil leak or not.

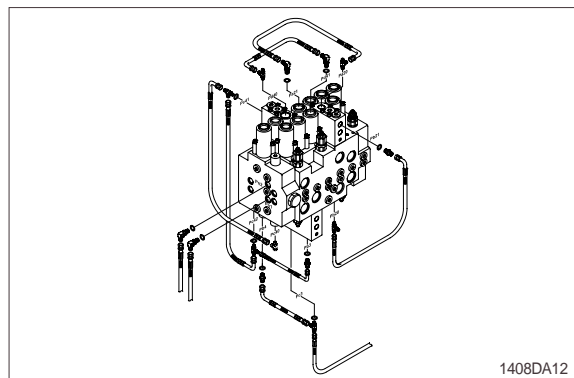
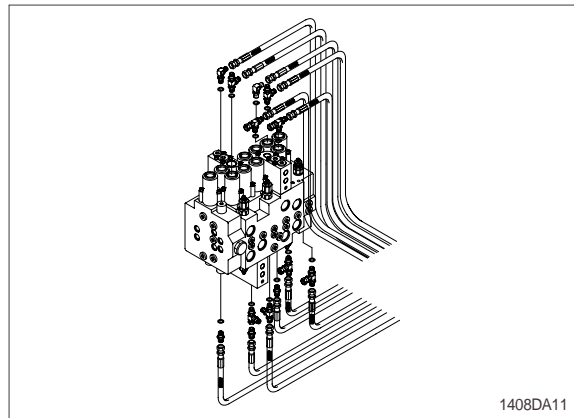
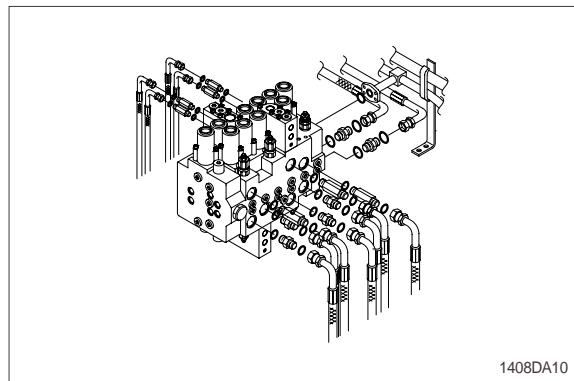

2. STRUCTURE(1/4)

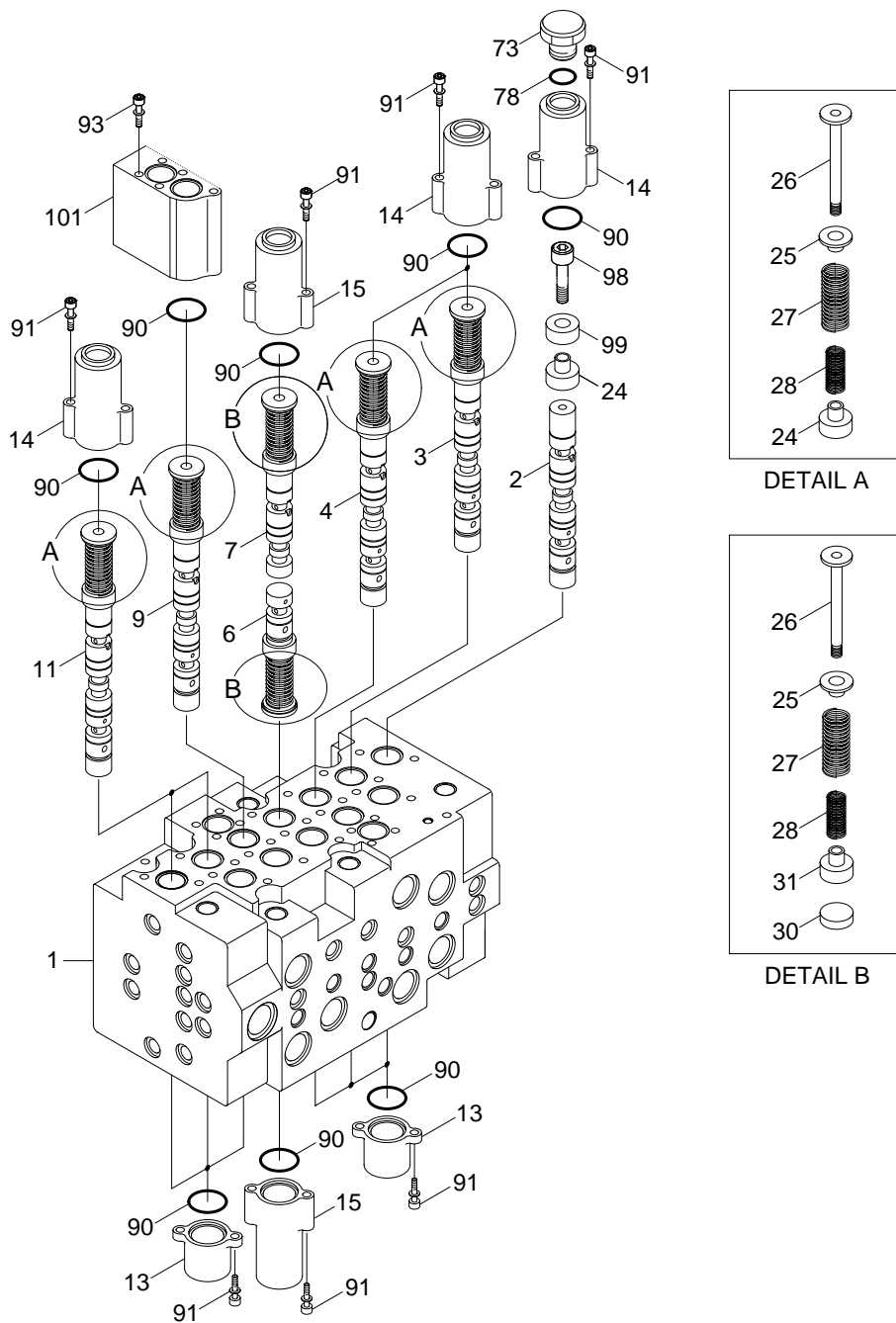

- | | | | | | |
|----|-------------|----|---------------|-----|------------------|
| 1 | Body | 14 | Pilot cover | 73 | Plug |
| 2 | Spool | 15 | Pilot cover | 78 | O-ring |
| 3 | Spool | 24 | Spring holder | 90 | O-ring |
| 4 | Spool | 25 | Spring holder | 91 | Socket head bolt |
| 6 | Spool | 26 | Spool end | 93 | Socket head bolt |
| 7 | Spool | 27 | Spring | 98 | Socket head bolt |
| 9 | Spool | 28 | Spring | 99 | Stopper |
| 11 | Spool | 30 | Stopper | 101 | Lock valve |
| 13 | Pilot cover | 31 | Spring holder | | |

17W78MC01

STRUCTURE(2/4)

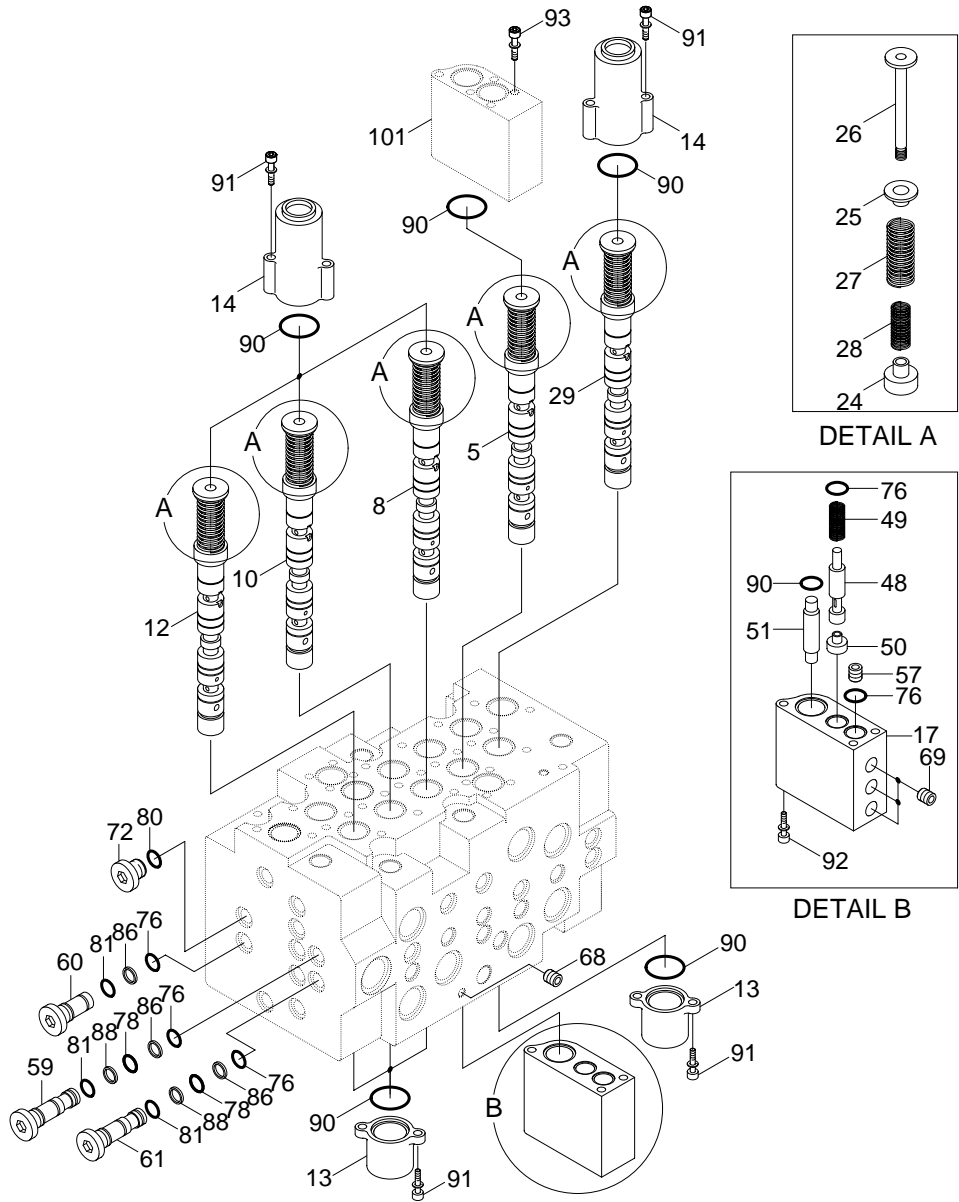

- | | | | | | |
|----|---------------|----|------------------|-----|------------------|
| 5 | Spool | 29 | Spool | 76 | O-ring |
| 8 | Spool | 48 | Selector spool | 78 | O-ring |
| 10 | Spool | 49 | Spring | 80 | O-ring |
| 12 | Spool | 50 | Stopper | 81 | O-ring |
| 13 | Pilot cover | 51 | Piston | 86 | Back-up ring |
| 14 | Pilot cover | 57 | Restrictor | 88 | Back-up ring |
| 17 | Pilot cover | 59 | Plug | 90 | O-ring |
| 24 | Spring holder | 60 | Plug | 91 | Socket head bolt |
| 25 | Spring holder | 61 | Restrictor | 92 | Socket head bolt |
| 26 | Spool end | 68 | Socket head plug | 93 | Socket head bolt |
| 27 | Spring | 69 | Socket head plug | 101 | Lock valve |
| 28 | Spring | 72 | Plug | | |

17W78MC02

STRUCTURE(3/4)

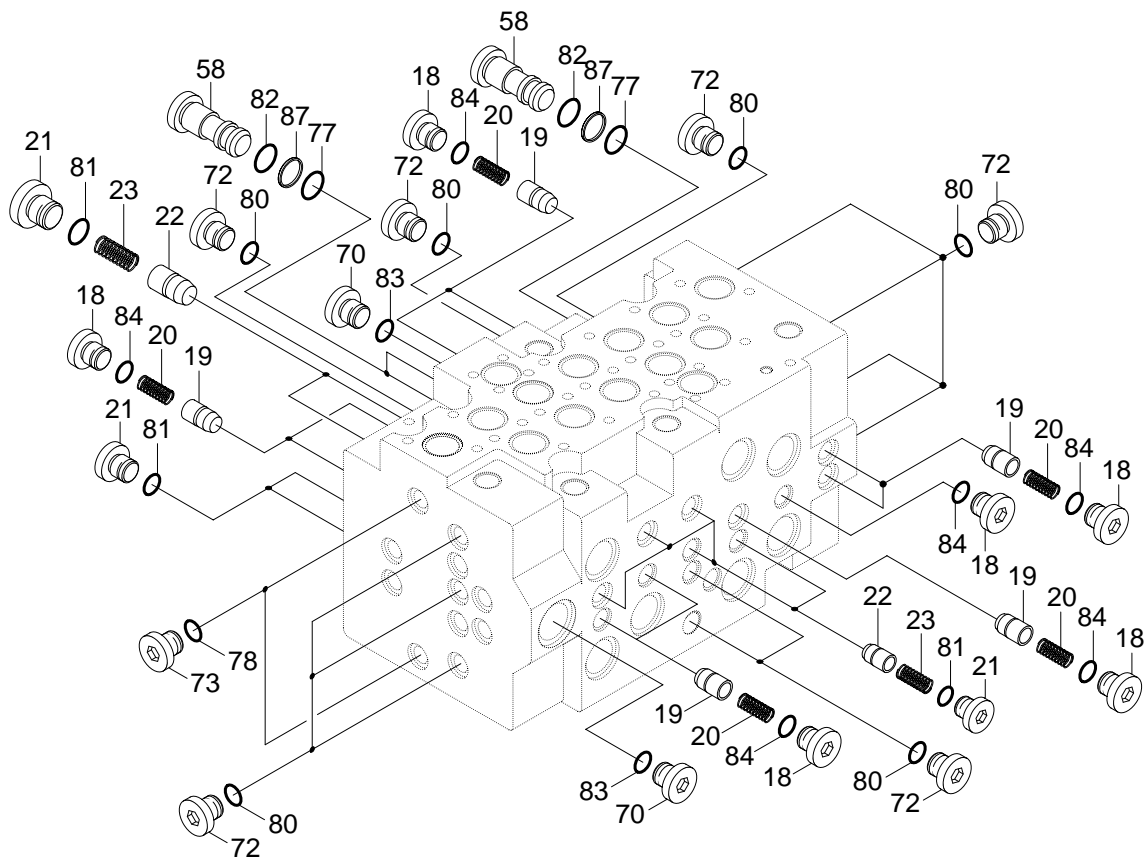

17W78MC03

18	Plug	58	Plug	80	O-ring
19	Check valve	70	Plug	81	O-ring
20	Check valve spring	72	Plug	82	O-ring
21	Plug	73	Plug	83	O-ring
22	Check valve	77	O-ring	84	O-ring
23	Check valve spring	78	O-ring	87	Back-up ring

STRUCTURE(4/4)

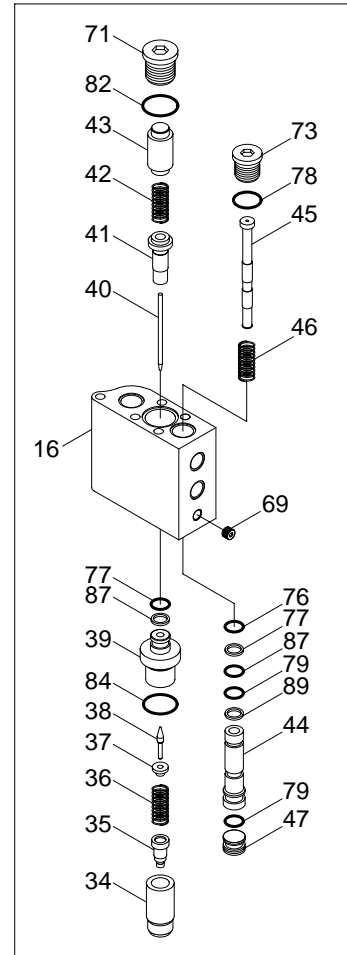
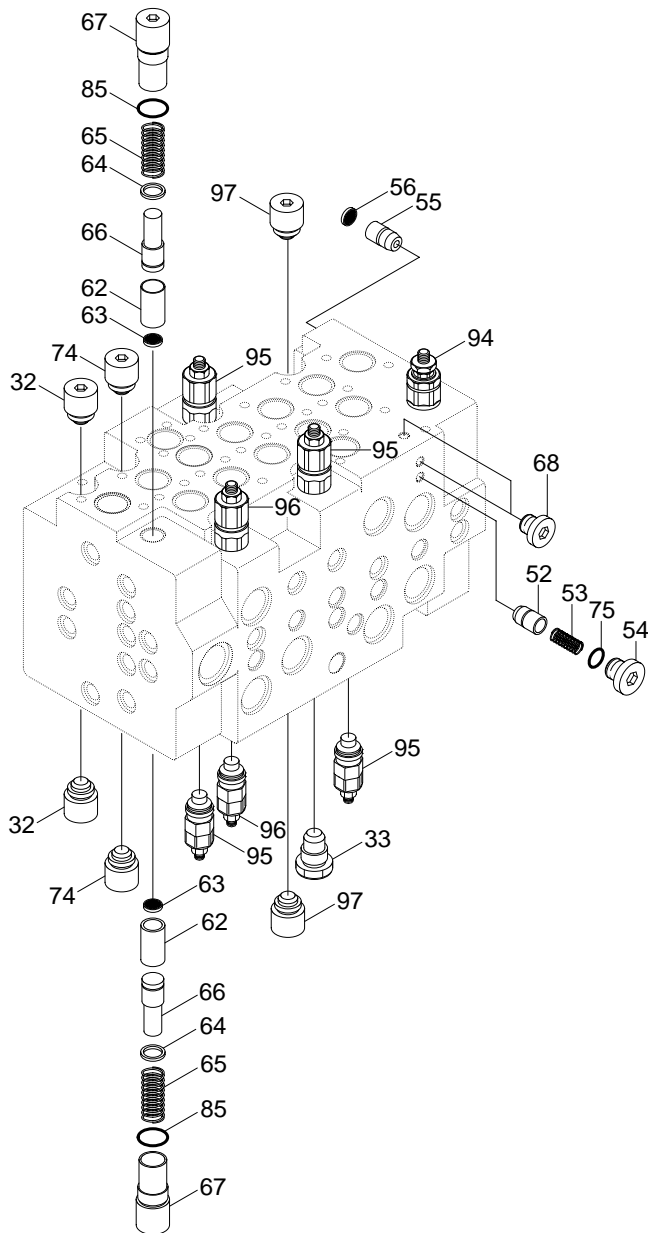

DETAIL OF LOCK VALVE

17W78MC04

- | | | | | | |
|----|-----------------------|----|--------------------|----|------------------------|
| 16 | Pilot cover | 47 | Lock valve plug | 74 | Relief valve plug |
| 32 | Relief valve plug | 52 | Check valve | 75 | O-ring |
| 33 | Relief valve plug | 53 | Check valve spring | 76 | O-ring |
| 34 | Lock valve | 54 | Plug | 77 | O-ring |
| 35 | Lock valve restrictor | 55 | Restrictor | 78 | O-ring |
| 36 | Lock valve spring | 56 | Coin type filter | 79 | O-ring |
| 37 | Spring holder | 62 | Negative poppet | 82 | O-ring |
| 38 | Poppet | 63 | Coin type filter | 84 | O-ring |
| 39 | Poppet seat | 64 | Spring holder | 85 | O-ring |
| 40 | Piston | 65 | Negative spring | 87 | Back-up ring |
| 41 | Piston guide | 66 | Negative piston | 89 | Back-up ring |
| 42 | Lock valve spring | 67 | Negative socket | 94 | Main relief valve |
| 43 | Piston | 68 | Plug | 95 | Socket head bolt |
| 44 | Lock valve socket | 69 | Plug | 96 | Over load relief valve |
| 45 | Lock valve spool | 71 | Plug | 97 | Make up check valve |
| 46 | Lock valve spring | 73 | Plug | | |

3. DISASSEMBLY AND ASSEMBLY

1) GENERAL PRECAUTIONS

- (1) All hydraulic components are manufactured to a high precision. Consequently, before disassembling and assembling them, it is essential to select an especially clean place.
- (2) In handling a control valve, pay full attention to prevent dust, sand, etc. from entering into it.
- (3) When a control valve is to be removed from the machine, apply caps and masking seals to all ports. Before disassembling the valve, recheck that these caps and masking seals are fitted completely, and then clean the outside of the assembly. Use a proper bench for working. Spread paper or a rubber mat on the bench, and disassemble the valve on it.
- (4) Support the body section carefully when carrying or transferring the control valve. Do not lift by the exposed spool, end cover section etc.
- (5) After disassembling and assembling of the component it is desired to carry out various tests (For the relief characteristics, leakage, flow resistance, etc.), but hydraulic test equipment is necessary for these tests. Therefore, even when its disassembling can be carried out technically, do not disassemble such components that cannot be tested, adjusted, and so on. Additionally one should always prepare clean cleaning oil, hydraulic oil, grease, etc. beforehand.

2) TOOLS

Before disassembling the control valve, prepare the following tools beforehand.

Name of tool	Quantity	Size(mm)
Vice mounted on bench(Soft jaws)	1 unit	
Hexagon wrench	Each 1 piece	5, 6, 10, 12 and 14
Socket wrench	Each 1 piece	27 and 32
Spanner	Each 1 piece	32(Main relief valve)

3) DISASSEMBLY

(1) Disassembly of spools without holding valve

Loosen hexagon socket head bolts with washer
(Hexagon wrench : 5mm)

Remove the pilot cover.

Pay attention not to lose the O-ring under the pilot cover.

Remove the spool assembly from the body by hand slightly.

When extracting each spool from its body, pay attention not to damage the body.

When extracting each spool assembly, it must be extracted from spring side only.

When any abnormal parts are found, replace it with completely new spool assembly.

When disassembled, tag the components for identification so that they can be reassembled correctly.

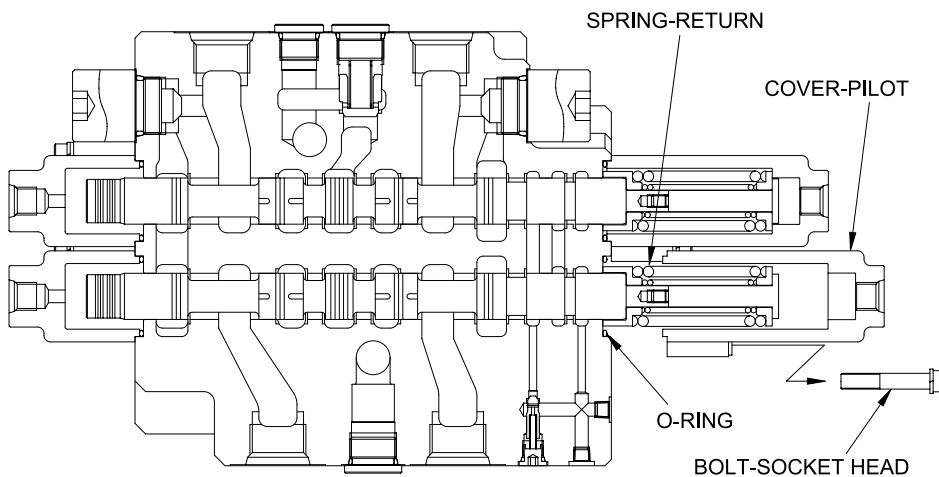

1408DA17

(2) Disassembly of spools with holding valve(Boom 1, Arm 1 spool)

Loosen hexagon socket head bolts with washer
(Hexagon wrench : 5mm)

Remove the pilot cover with internal parts.

Pay attention not to lose the O-ring and the poppet under the pilot cover.
Pay attention not to damage the "piston A" under pilot cover.

Remove the spool assembly from the body by hand slightly.

When extracting each spool from its body, pay attention not to damage the body.

When extracting each spool assembly, it must be extracted from spring side only.

When any abnormal parts are found, replace it with completely new spool assembly.

When disassembled, tag the components for identification so that they can be reassembled correctly.

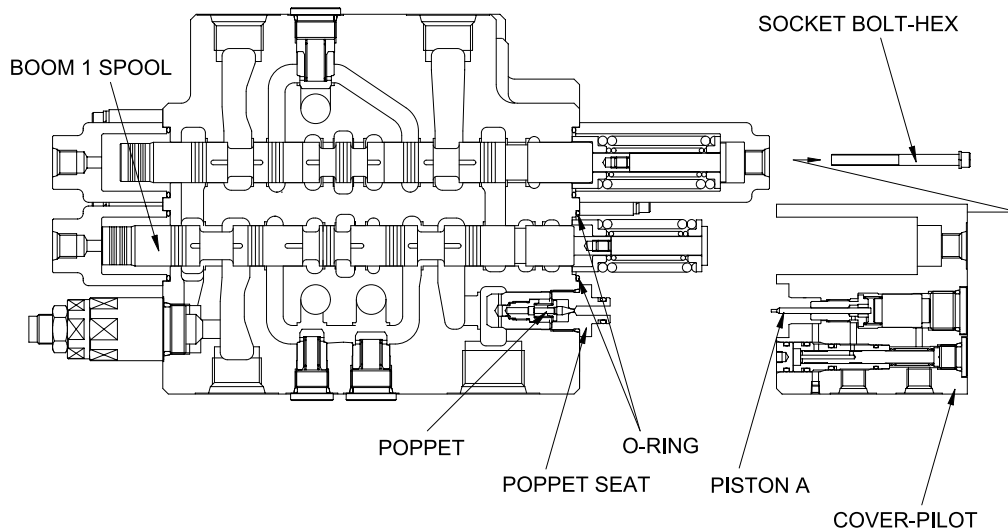

1408DA22

(3) Disassembly of the holding valve

Remove the pilot cover with the holding valve as discribed on previous page.

Do not disassembled internal parts of the pilot cover.

Loosen the poppet seat and remove the poppet, the spring seat, the spring and the check.
(Spanner : 32mm)

Pay attention not to lose the poppet.

Do not disassembled internal parts of the check.

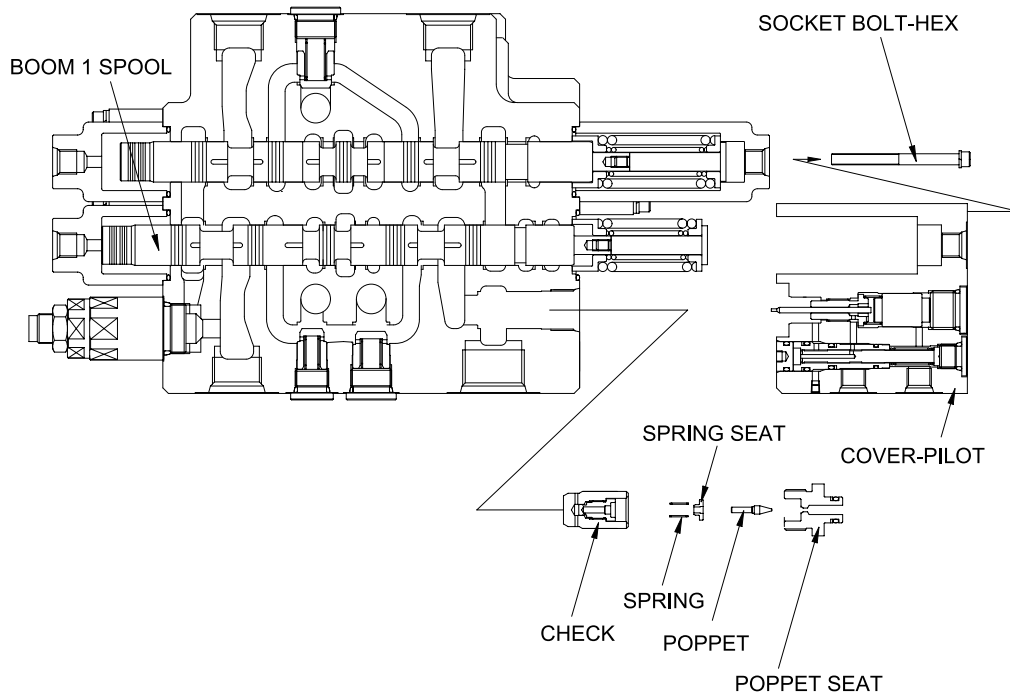

1408DA23

(4) Disassembly of the load check valve and the negative relief valve

The load check valve

a. Fix the body to suitable work bench.

Pay attention not to damage the body.

b. Loosen the plug (Hexagon wrench : 10mm).

c. Remove the spring and the load check valve with pincers or magnet.

The negative relief valve

a. Loosen the socket (Hexagon wrench : 12mm).

b. Remove the spring, the spring holder, the piston and the negative control poppet.

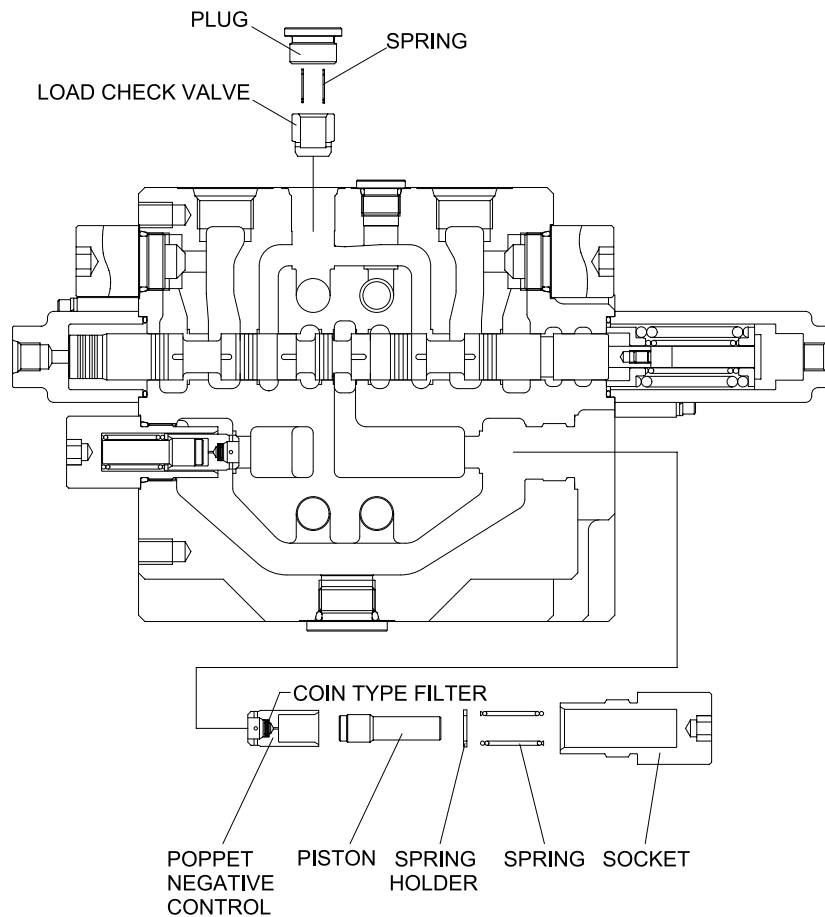

1408DA21

(5) Disassembly of the main and overload relief valve

Fix the body to suitable work bench.

Remove the main relief valve.

(Spanner : 32mm)

Remove the overload relief valve.

(Spanner : 32mm)

When disassembled, tag the relief valve for identification so that they can be reassembled correctly.

Pay attention not to damage seat face.

When any abnormal parts are found, replace it with completely new relief valve assembly.

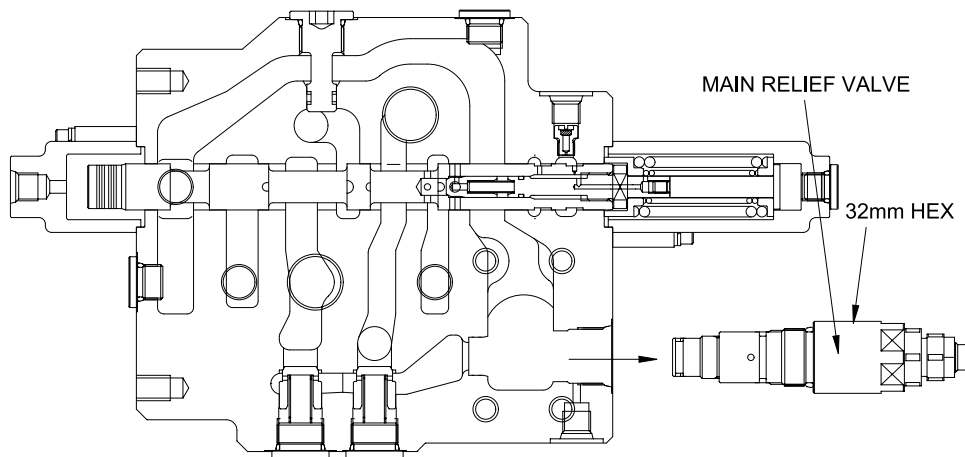

1408DA19

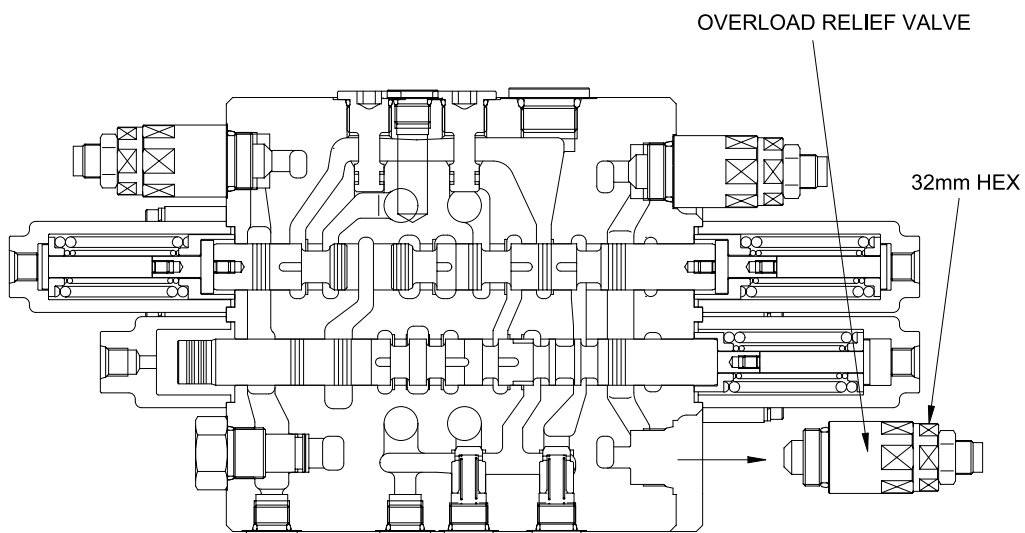

1408DA20

(6) Inspection after disassembly

Clean all disassembled parts with clean mineral oil fully, and dry them with compressed air. Then, place them on clean papers or cloths for inspection.

Control valve

- a. Check whole surfaces of all parts for burrs, scratches, notches and other defects.
- b. Confirm that seal groove faces of body and block are smooth and free of dust, dent, rust etc.
- c. Correct dents and damages and check seat faces within the body, if any, by lapping.
Pay careful attention not to leave any lapping agent within the body.
- d. Confirm that all sliding and fitting parts can be moved manually and that all grooves and paths are free foreign matter.
- e. If any spring is broken or deformed, replace it with new one.
- f. When a relief valve does not function properly, repair it, following it's the prescribed disassembly and assembly procedures.
- g. Replace all seals and O-rings with new ones.

Relief valve

- a. Confirm that all seat faces at ends of all poppets and seats are free of defects and show uniform and consistent contact faces.
- b. Confirm manually that main poppet and seat can slide lightly and smoothly.
- c. Confirm that outside face of main poppet and inside face of seat are free from scratches and so on.
- d. Confirm that springs are free from breakage, deformation, and wear.
- e. Confirm that orifices of main poppet and seat section are not clogged with foreign matter.
- f. Replace all O-rings with new ones.
- g. When any light damage is found in above inspections, correct it by lapping.
- h. When any abnormal part is found, replace it with a completely new relief valve assembly.

4) ASSEMBLY

(1) General precaution

In this assembly section, explanation only is shown.

For further understanding, please refer to the figures shown in the previous structure & disassembly section.

Pay close attention to keeping all seals free from handling damage and inspect carefully for damage before using them.

Apply clean grease or hydraulic oil to the seal so as to ensure it is fully lubricated before assembly.

Do not stretch seals so much as to deform them permanently.

In fitting O-rings, pay close attention not to roll them into their final position in addition, a twisted O-ring cannot easily untwist itself naturally and could thereby cause inadequate sealing and thereby both internal and external oil leakage.

Tighten fitting bolts for all sections with a torque wrench adjusted to the respective tightening torque.

Do not reuse removed O-rings and seals.

(2) Load check valve

Assemble the load check valve and spring.

Put O-rings on to plug.

Tighten plug to the specified torque.

- Hexagon wrench : 10mm
- Tightening torque : 6~7kgf · m(43.4~50.6lbf · ft)

(3) Negative control relief valve

Assemble the nega-con poppet, piston, spring holder and spring together into body.

Put O-ring on to plug and tighten the latter to its specified torque.

- Hexagon wrench : 12mm
- Tightening torque : 8~9kgf · m(57.8~65.1lbf · ft)

(4) Main relief, port relief valves

Install main relief valve, overload relief valve into the body and tighten to the specified torque.

Component	Tools	Tightening torque	
		kgf · m	lbf · ft
Main relief valve	Spanner 32mm	8~9	57.8~65.1
Overload relief valve	Spanner 32mm	8~9	57.8~65.1

(5) Main spools

Carefully insert the previously assembled spool assemblies into their respective bores within of body.

Fit spool assemblies into body carefully and slowly. Do not under any circumstances push them forcibly in.

(6) Covers

Fit spool covers to the non-spring assembly end of the spool, and tighten the hexagonal socket head bolts to the specified torque.

- Hexagon wrench : 5mm
- Tightening torque : 1~1.1kgf · m(7.2~7.9lbf · ft)

Confirm that O-rings have been fitted.

Fit spring covers to the spring end for the spools, and tighten hexagon socket head bolts to the specified torque.

- Hexagon wrench : 5mm
- Tightening torque : 1~1.1kgf · m(7.2~7.9lbf · ft)

Confirm that O-rings have been fitted.

(7) Holding valves

Assemble the check, spring seat and poppet together into body.

Tighten the poppet seat to the specified torque.

- Spanner : 26mm
- Tightening torque : 6~7kgf · m(43.4~50.6lbf · ft)

Fit the "piston A" under pilot cover with internal parts into hole on the poppet seat.

Tighten hexagon socket head bolt to specified torque.

- Hexagon wrench : 5mm
- Tightening torque : 1~1.1kgf · m(7.2~7.9lbf · ft)