

## GROUP 10 REAR AXLE

### 1. REMOVAL REAR AXLE

- 1) Rear axle mounting bolt(1, M20)
  - Tightening torque :  $58 \pm 6.3(\text{kgf} \cdot \text{m})$   
( $419 \pm 45.5\text{lb} \cdot \text{ft}$ )
- 2) Propeller shaft mounting bolt(2, M10)
  - Tightening torque :  $5.9 \pm 0.6\text{kgf} \cdot \text{m}$   
( $42.7 \pm 4.3\text{lb} \cdot \text{ft}$ )
- 3) Wheel nut(3, M20)
  - Tightening torque :  $60^{+0}_{-5}\text{kgf} \cdot \text{m}$   
( $434^{0}_{-36}\text{lb} \cdot \text{ft}$ )
- 4) Hose assy(4, PF 1/4)
  - Tightening torque :  $4\text{kgf} \cdot \text{m}(28.9\text{lb} \cdot \text{ft})$
- 5) Axle weight : 400kg(890lb)

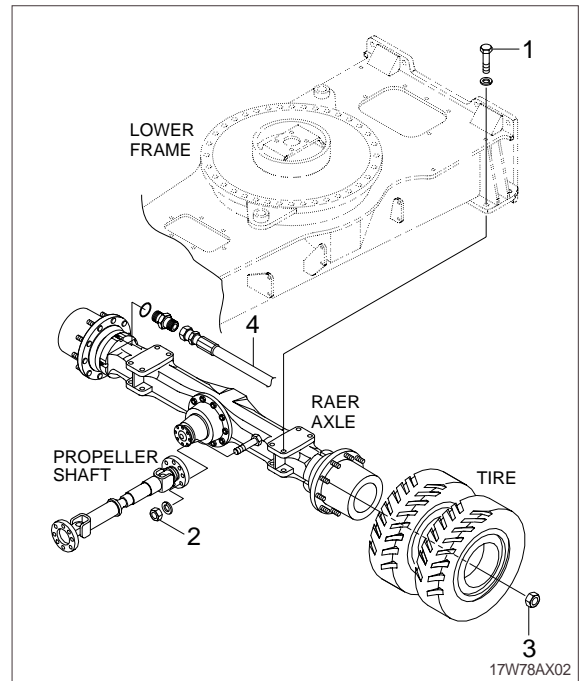

## 2. GENERAL INSTRUCTIONS

### 1) GENERAL WORKING INSTRUCTIONS

- (1) This manual has been developed for the skilled serviceman, trained by the ZF-Passau.
- (2) During all operations, pay attention to cleanliness and skilled working.  
Therefore, axle removed from the machine, must be cleaned prior to open them.
- (3) We assume that the special tools, specified by ZF, will be used.  
The special tools are available from ZF-Passau.
- (4) After the disassembly, all components must be cleansed, especially corners, cavities and recesses of housing and covers.
- (5) The old sealing compound must be carefully removed.
- (6) Check lubricating holes, grooves and pipes for free passage. They must be free of residues, foreign material or protective compounds.
- (7) The latter refers especially to new parts.
- (8) Parts which have been inevitably damaged in a disassembly operation, must be generally replaced by new ones, e.g. rotary seal rings, O-rings, U-section rings, cap boots, protective caps etc..
- (9) Components such as roller bearings, thrust washers, synchronizing parts etc. which are subject to normal wear in automotive operation, must be checked by the skilled Serviceman.  
He will decide if the parts can be reused.
- (10) For the heating of bearings etc., hot plates, rod heaters or heating furnaces must be used.
- (11) Never heat parts directly with the flame. An auxiliary solution would be to immerse the bearing in a vessel filled with oil, which is then heated with the flame.  
In this way, damage to the bearings could be avoided.
- (12) Ball bearings, covers, flanges and parts like that must be heated to about 90 to 100°C.
- (13) Hot-mounted parts must be reset after cooling in order to assure a proper contact.
- (14) Before pressing shafts, bearings etc. in position, both parts must be lubricated.
- (15) During to reassembly, all specified adjustment values, testing specifications and tightening torque must be respected.
- (16) After the repair, units are filled up with oil.
- (17) After the oil filling, the oil level plugs and oil drain plugs must be tightened to the specified tightening torque.

## **2) IMPORTANT INSTRUCTIONS CONCERNING THE LABOUR SAFETY**

- (1) In principle, repairers are themselves responsible for the labour safety.
- (2) The observance of all valid safety regulations and legal rules is a precondition to prevent damage to individuals and products during the maintenance and repair operations.
- (3) Before starting the work, the repairers have to make themselves familiar with these regulations.
- (4) The proper repair of these products requires especially trained personnel.
- (5) The repairer himself is obliged to provide for the training.

## **3) LUBRICANT SPECIFICATIONS**

- (1) Gear oils with limited - slip additives.
- (2) API GL-5
- (3) MIL-L-2105D(SAE 85W-90, 85W-140 with LS-Additive)

## 4) BRAKE LINING WEARING TEST

### (1) General

The brake lining wearing test gives a limited information about the overall condition of the brake plate pack - without disassembly of the planetary carrier, resp. of the plates.

The wearing test has to be carried out in case of the following criteria :

- In the course of the oil change intervals(min. once a year)
- Braking noises
- Reduced braking power
- Change of deceleration, of the brake fluid level as well as of the brake pressure
- In case of a general change of the brake performance.

Carry out the wearing test on both final drive sides.

- Permitted piston stroke max. : 5.0mm
- Piston stroke in new condition of the plate pack : 3.1-3.5mm

### (2) Carry out the wearing test

Turn the planetary carrier until screw plug A(M16 x 1.5) is in the upper position(12 o'clock position).

Now, remove the screw plug.

Apply the brake(required brake pressure min. 40bar).

Screw measuring screw(M16 x 1.5) in until contact is obtained and tighten it with a torque of  $1\text{kg} \cdot \text{m}$ .

Determine dimension X according to the figure on the right.

Release the brake and equalize the plate clearance by resetting the measuring screw.

Torque limit  $1\text{kg} \cdot \text{m}$ .

Determine dimension Y according to the figure on the right.

The difference of the two dimensions (X-Y) corresponds to the piston stroke (actual state).

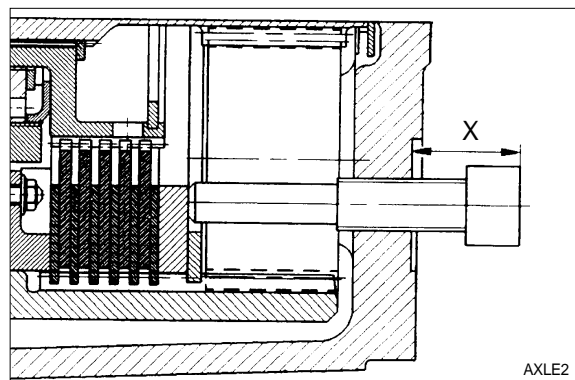
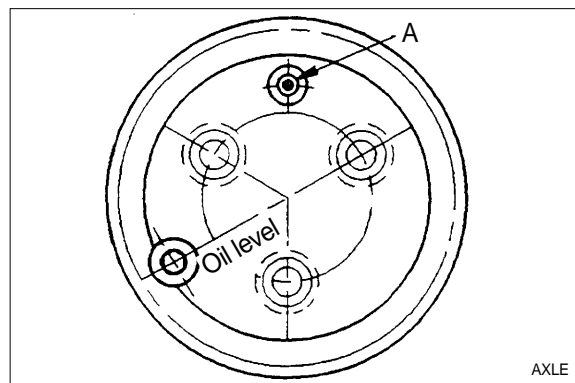

### (3) Result

If the max. permitted piston stroke(5.0mm) is exceeded, the lining plates must be renewed on both final drive sides.

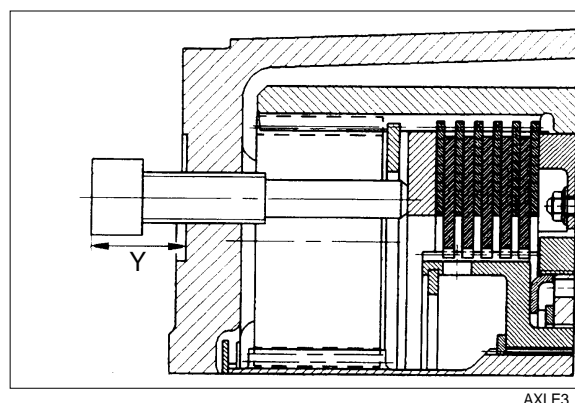

### 3. FINAL DRIVE DISASSEMBLY AND ASSEMBLY

#### 1) DISASSEMBLY

- (1) Loosen screw plug, turn planetary carrier 180° and drain oil.

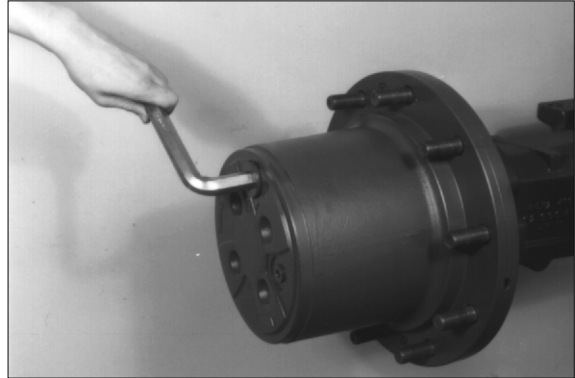

17W78RA001

- (2) Loosen both socket head screws and separate planetary carrier from the hub.

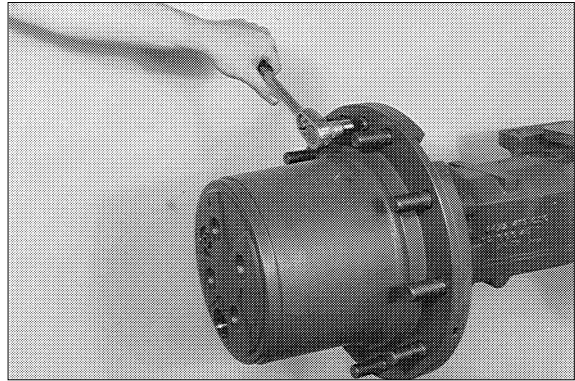

17W78RA002

- (3) Squeeze circlip out and pull off planetary gears.

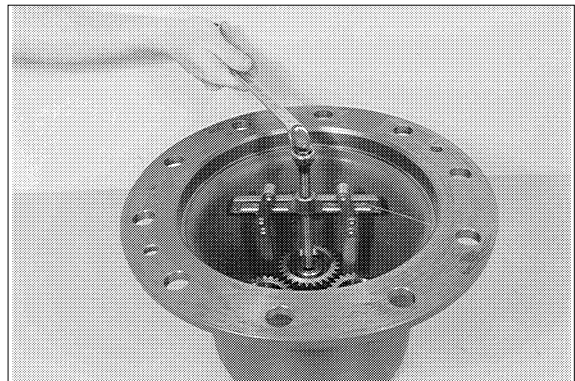

17W78RA003

- (4) Squeeze angle ring out and pull bearing inner race (along with cylindrical rollers) out of the planetary gear.

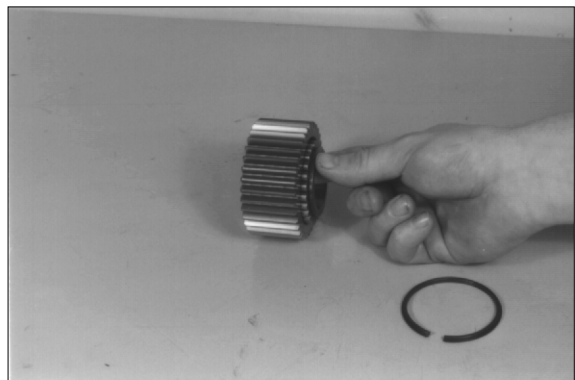

17W78RA004

- (5) Pull sun-gear shaft along with inner plate carrier from the stub shaft, resp. out of the plate pack.  
Remove released thrust washer.

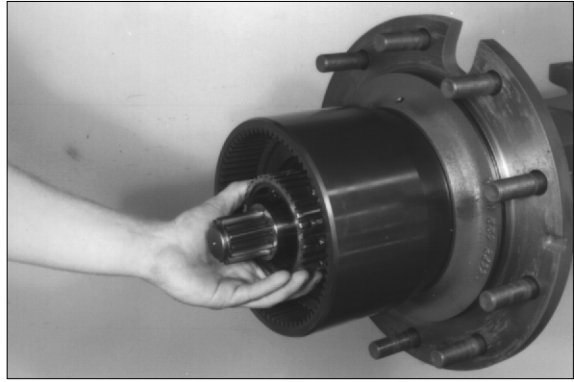

17W78RA005

- (6) Squeeze circlip out.



17W78RA006

- (7) Remove backing plate and plate pack.



17W78RA007

- (8) Squeeze circlip out.



17W78RA008

### Loosen slotted nut

(9) The draft on the right shows the components of the special tool for the loosening of the slotted nut.

- 1 Hook spanner
- 2 Spacer
- 3 Centering disk

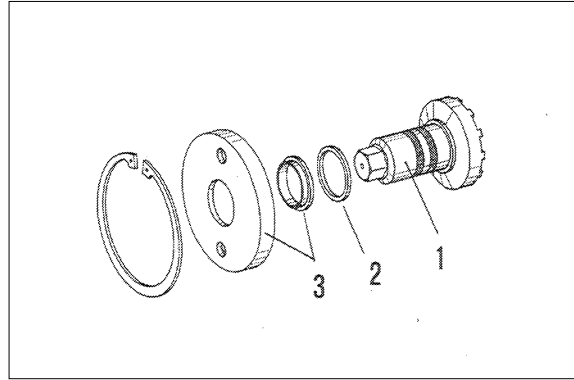

17W78RA009

(10) Position hook spanner and fix it by means of circlip.

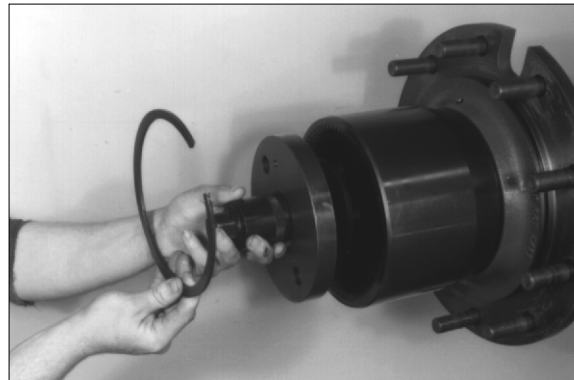

17W78RA010

(11) Loosen slotted nut.

Pay attention to the released internal gear. By the backing up of the hook spanner on the circlip, the internal gear is pulled from the hub carrier during the screwing off of the slotted nut.

Now, remove slotted nut, angle ring and O-ring.



17W78RA011

Because of the high torque limit of the slotted nut, it is absolutely necessary to back up the axle, resp. the assembly car at the loosening of the slotted nut.

Therefore, we recommend the use of a power-operated screwdriver as figure.



17W78RA012

(12) Drive piston uniformly out of the cylinder bore.



17W78RA013

(13) Loosen lock nut as well as socket head screws, and remove released components.

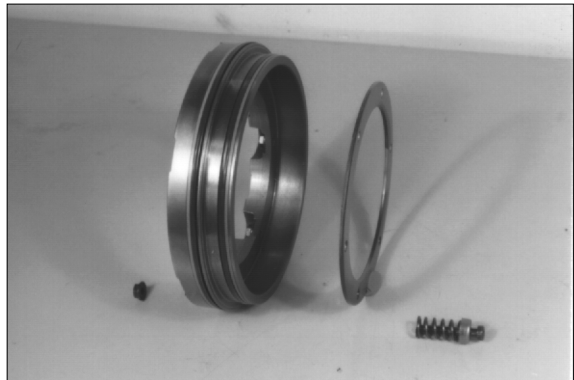

17W78RA014

(14) Pull hub from the hub carrier end.  
Pay attention to the released bearing inner race and spacer.

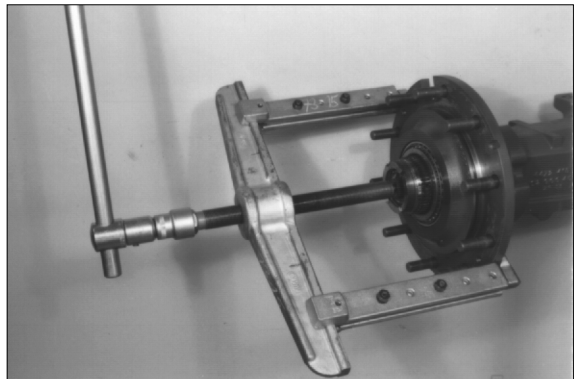

17W78RA015

(15) Pry sealing ring out of the hub bore and remove bearing inner race.  
If necessary, drive both bearing outer races out of the hub bores.  
If the bearing inner race as well as the sealing ring remains on the hub carrier disassemble as described following (16) and (17).



17W78RA016

(16) Pull tapered roller bearing from the end of the hub carrier.

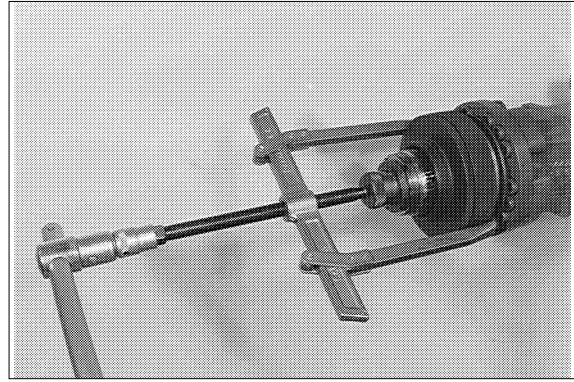

17W78RA017

(17) Remove sealing ring.

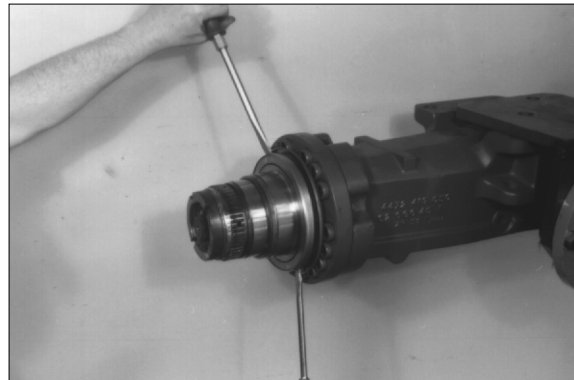

17W78RA018

(18) Pry supporting plate from the collar of the hub carrier.

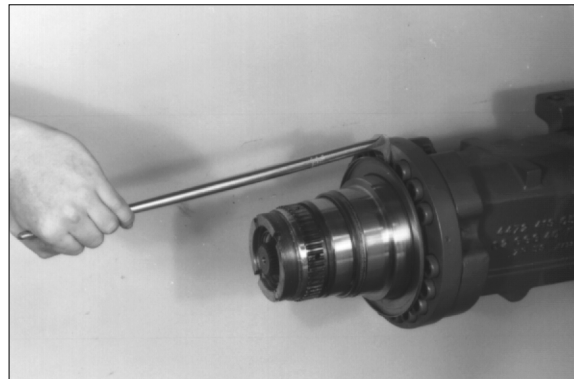

17W78RA019

(19) Pull stub shaft out of the axle housing and remove shaft seal (Arrow).

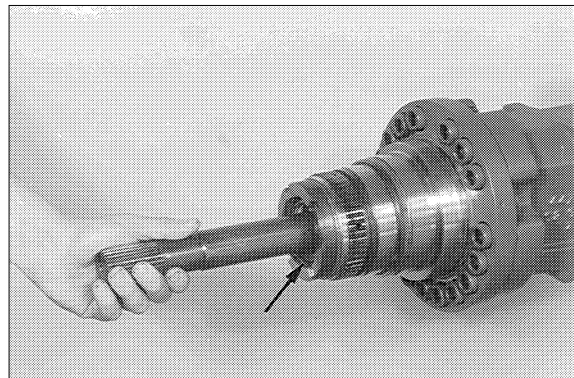

17W78RA020

- (20) Loosen socket head screws and separate hub carrier from axle housing.

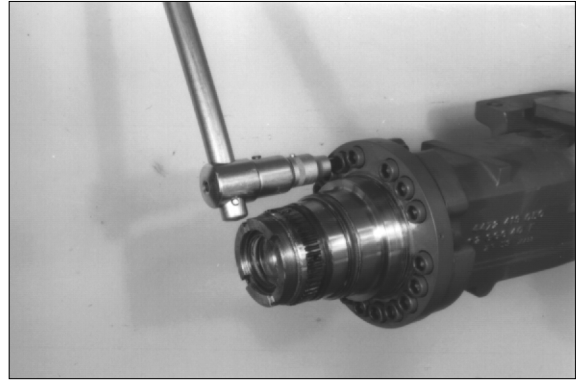

17W78RA021

## 2) REASSEMBLY

### Hub carrier

- (1) Close bores by means of king plug, see Arrows.  
Insert O-ring(1) into the annular groove and grease it.  
Prior to install the screw plugs clean the oil holes carefully from residues (preserving agent).

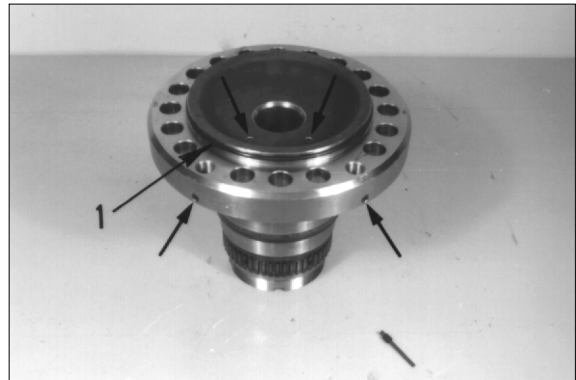

17W78RA022

- Fasten hub(1) carrier on the axle housing by means of socket head screws(M16).  
· Tightening torque : 28.5kgf · m(206lb · ft)

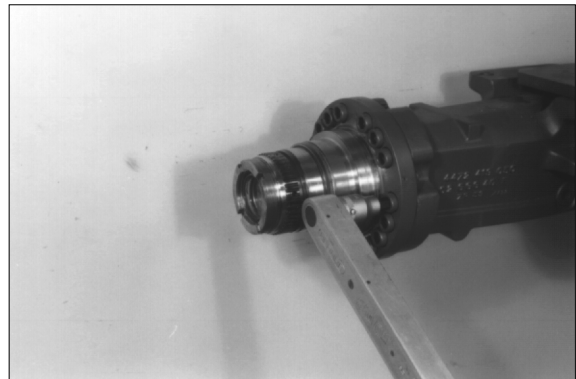

17W78RA023

- (2) Install supporting plate.  
Only by application of the prescribed driver, the exact installation position of the supporting plate is obtained.

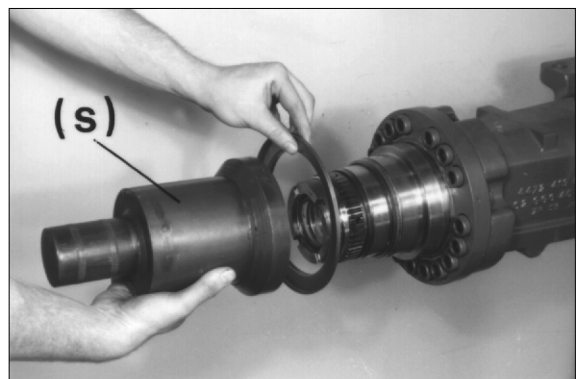

17W78RA024

- (3) Insert shaft seal against shoulder.  
Pay attention to the installation position, the projecting sealing lip must show outwards.  
Wet outer diameter with sealing compound.

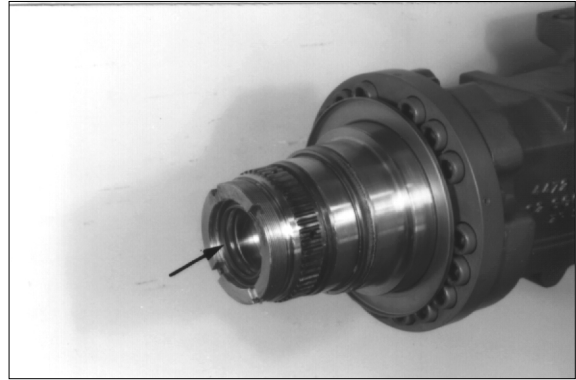

17W78RA025

### Hub

- (4) Install wheel studs.



17W78RA026

- (5) Insert bearing outer races into both hub bores until contact is obtained.

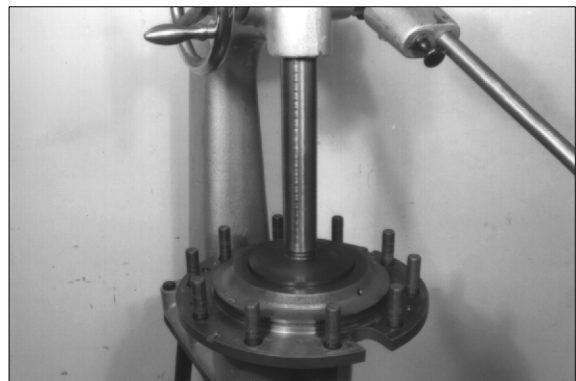

17W78RA027

### Adjust rolling moment of the wheel bearing[following (6) to (12)]

- Rolling moment : 0.8-1.2kg · m(5.8-8.7lb · ft)
- (6) Heat bearing inner race and assemble it until contact is obtained.



17W78RA028

(7) Place adjusting ring e.g. 4.45mm(empirical value) against the hub carrier collar until contact is obtained.

If the hub as well as both wheel bearings have not been renewed, we recommend to install the existing spacer again.

Decisive however, is the rolling moment of the wheel bearing[following (12)].

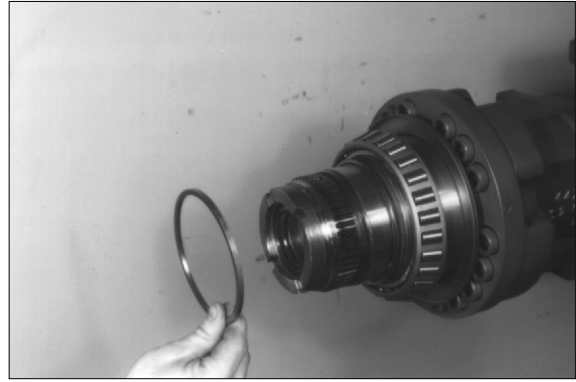

17W78RA029

(8) Assemble hub(without shaft seal) and fix it by means of heated bearing inner race.

The installation of the shaft seal is carried out after the adjustment of the wheel bearing.

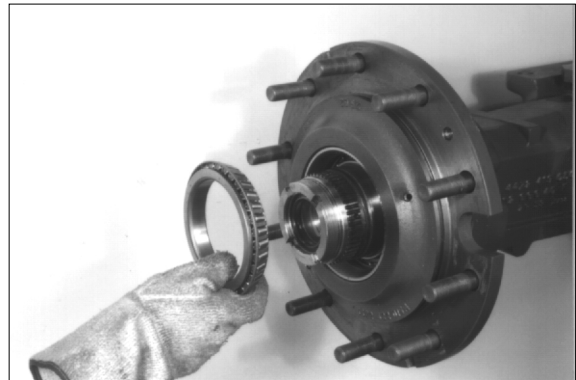

17W78RA030

### Tighten slotted nut

(9) The draft shows the components of the special tool.

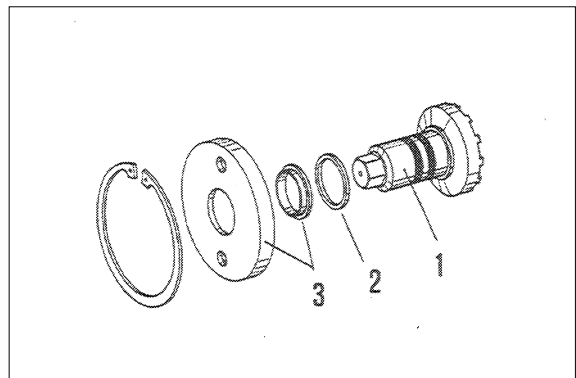

17W78RA031

(10) Cover thread of slotted nut with lubricant and screw on by hand.

Position hook spanner and fix it by means of circlip.

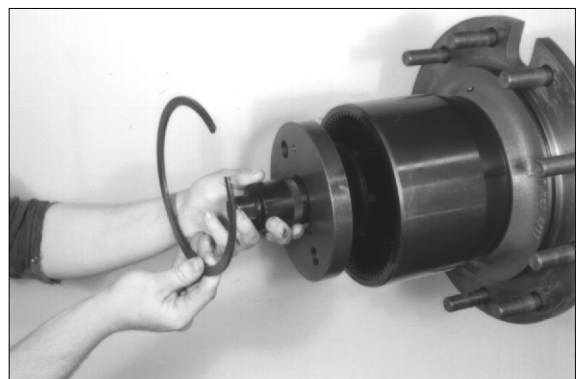

17W78RA032

(11) Tighten slotted nut.

- Tightening torque :  $158_{0}^{+51}$  kgf · m  
( $1143_{0}^{+369}$  lb · ft)

During the tightening, turn the hub several times through in both directions.

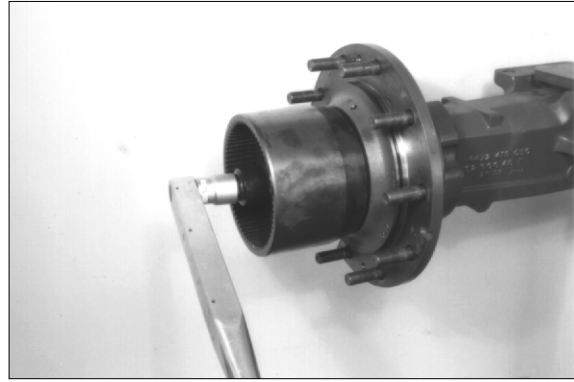

17W78RA033

Because of the high torque limit of the slotted nut, it is absolutely necessary to back up of the axle, resp. the assembly car at the tightening of the slotted nut.

Therefore, we recommend the use of a power-operated screwdriver.



17W78RA034

(12) Check the rolling moment of the wheel bearing, resp. traction force by means of a spring scale.

**Example**

- Bearing rolling moment:  $T(0.8-1.2\text{kg} \cdot \text{m})$
- Traction force :  $F$
- Hub radius :  $r(0.19\text{m})$
- $F = T/r = 4.28-6.42\text{kg}$

In case of new bearings, aim at the higher value.

Pay attention to the different hub diameter (according to the version).

In case of deviations from the required rolling moment, correct again with corresponding adjusting ring previous (7), repeat adjustment procedure (6) to (12).



17W78RA035

- (13) Loosen slotted nut again, remove internal gear and huh.

Heat bearing inner race (about 300°C) and insert it.

To avoid the cooling down of the bearing inner race, the reassembly of the shaft seal as well as the assembling of the hub [following (14) - (16)] must be carried out immediately after the insertion of the heated bearing inner race.

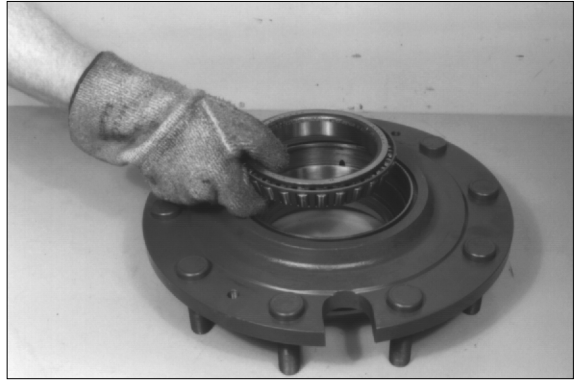

17W78RA036

- (14) Install shaft seal.

Wet outer diameter with sealing compound.

Only by application of the prescribed driver, the exact installation position of the shaft seal is obtained.

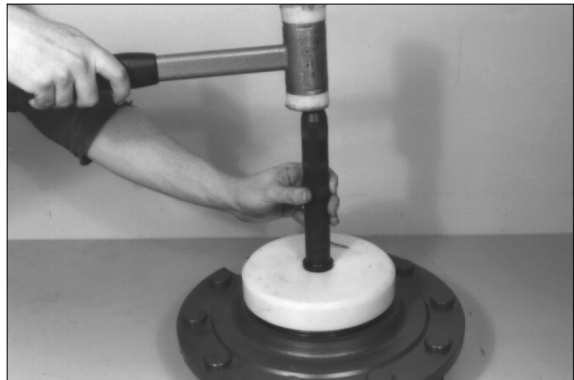

17W78RA037

- (15) Assemble hub until contact is obtained and install determined adjusting ring.

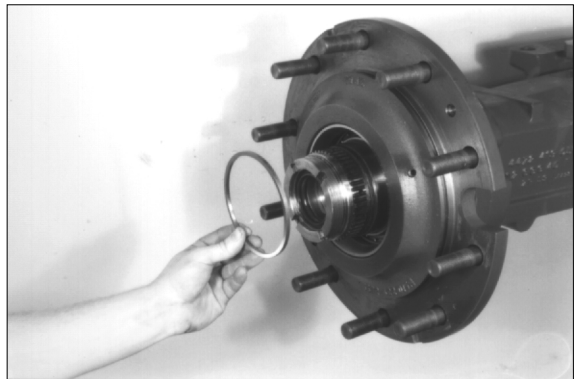

17W78RA038

- (16) Heat bearing inner race and assemble it until contact is obtained.

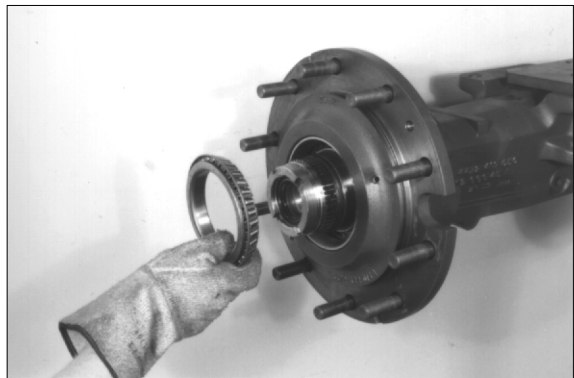

17W78RA039

### Internal gear

(17) Close bores by means of king plug.

Prior to install the king plugs, clean the oil holes carefully from residues (preserving agent).

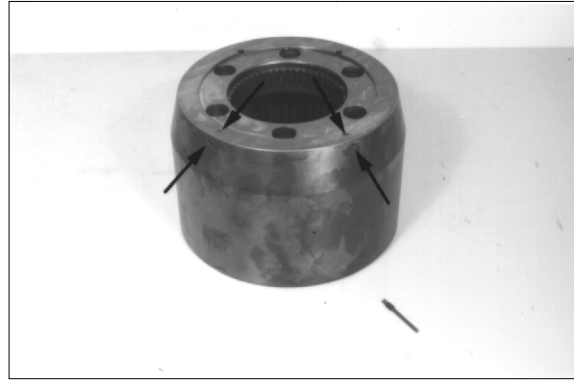

17W78RA040

(18) Insert supporting disk into the piston.



17W78RA041

(19) Fix supporting disk provisionally by means of compression springs, spring cage and socket head screws.

Insert grooved rings and back-up rings into the annular grooves.

Installation position.

Now, oil grooved rings as well as back-up rings (use W-10 oil).

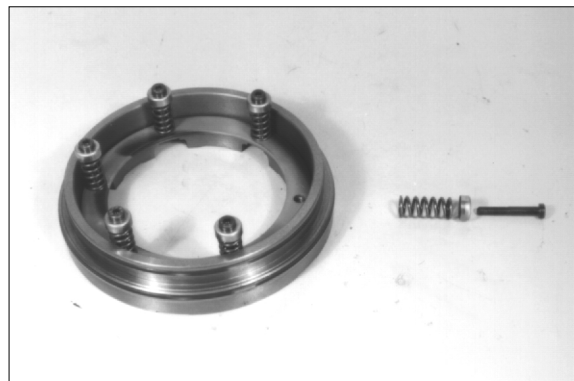

17W78RA042

(20) Installation position.

Now, oil grooved rings as well as back-up rings (use W-10 oil).

- 1 Piston
- 2 Back-up ring
- 3 Grooved ring
- X Pressure chamber

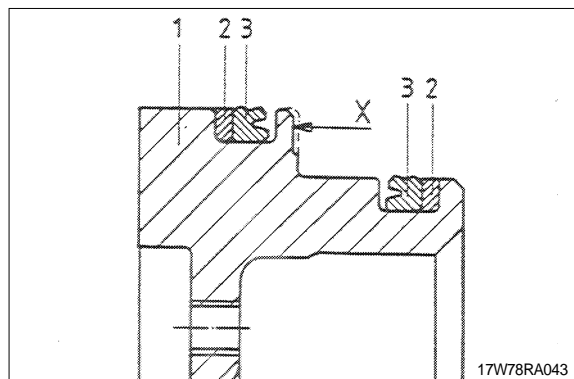

17W78RA043

(21) Introduce piston carefully and press it against shoulder.

To avoid the shearing off, resp. the tipping of the grooved rings, install the piston with utmost care (by means of a hand press).

Pay attention to the radial installation position.



17W78RA044

(22) Adjust dimension  $X=3.75\sim 4.25\text{mm}$  by means of socket head screws.

Pay attention to the exact contact of the piston in the internal gear.

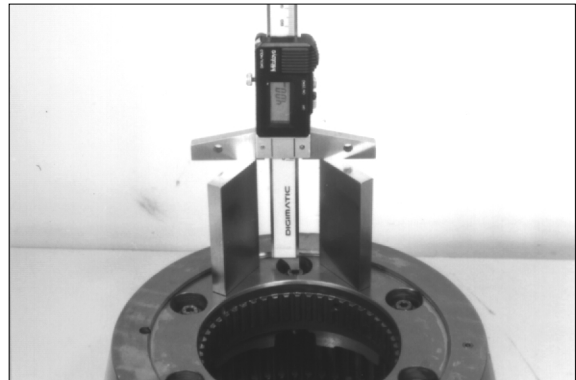

17W78RA045

(23) Dimension : X

- 1 Internal gear
- 2 Piston
- 3 Socket head screws
- 4 Spring cage
- 5 Compression spring
- 6 Supporting disk
- 7 Lock nut

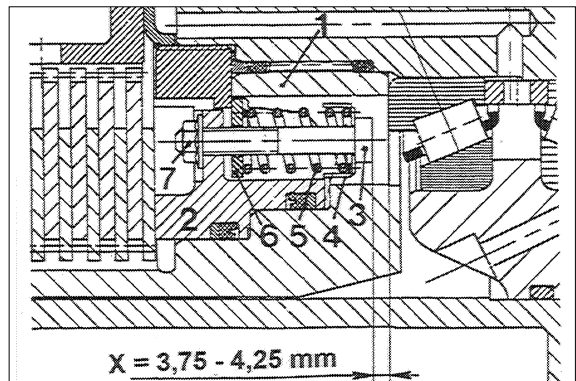

17W78RA046

(24) Lock socket head screws by means of lock nuts.

· Tightening torque :  $1.1\text{kgf} \cdot \text{m}$  ( $8.1\text{lb} \cdot \text{ft}$ )

Wet thread of lock nuts with loctite type No.242.

Only use of new lock nuts permitted.

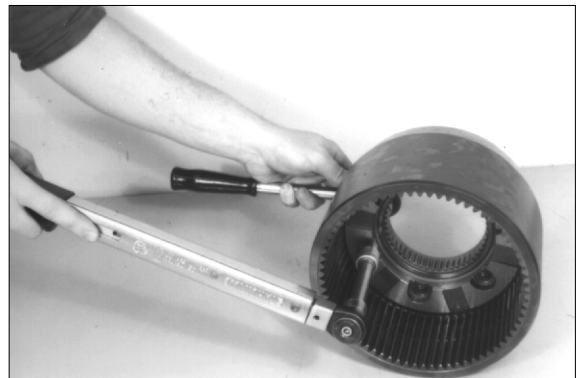

17W78RA047

(25) Insert O-ring into the annular groove of the hub carrier and oil it.

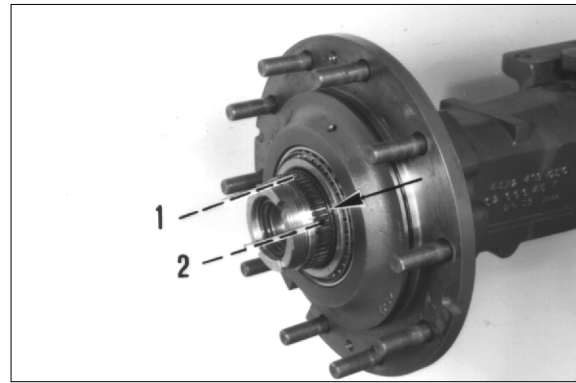

17W78RA048

(26) Guide internal gear over the splines of the hub carrier.  
Pay attention to the radial installation position the exact alignment of the two oil holes(hub carrier/internal gear) must be absolutely ensured.  
Position of the oil holes 1 and 2 on the hub carrier.

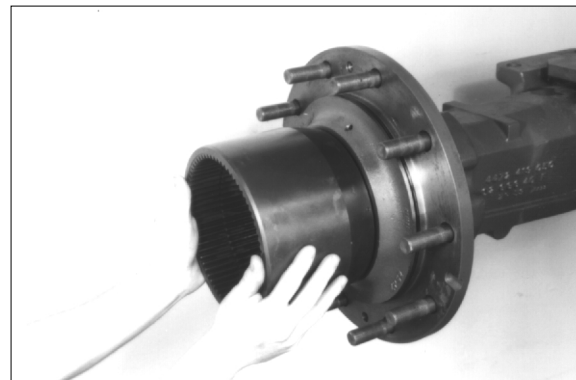

17W78RA049

(27) For the present, pull internal gear against shoulder, using slotted nut.  
Now, remove slotted nut again.



17W78RA050

(28) Insert O-ring(1) uniformly into the gap of the hub carrier and internal gear.  
Install subsequently angle ring(2).  
Oil O-ring and angle ring.  
Pay attention to the installation position of the angle ring-install stepped plane surface facing the O-ring.

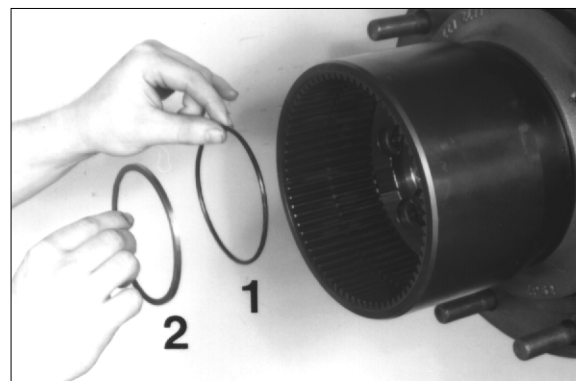

17W78RA051



(32) Fix slotted nut by means of circlip.

The locking of the slotted nut is permitted only on one of the two the upper grooves as figure.

If necessary, increase the torque limit of the slotted nut within the tolerance range.

- Tightening torque :  $158_{0}^{+56}$  kgf · m  
( $1143_{0}^{+405}$  lb · ft)

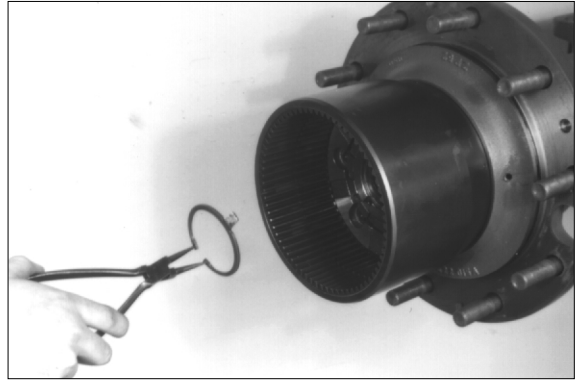

17W78RA056

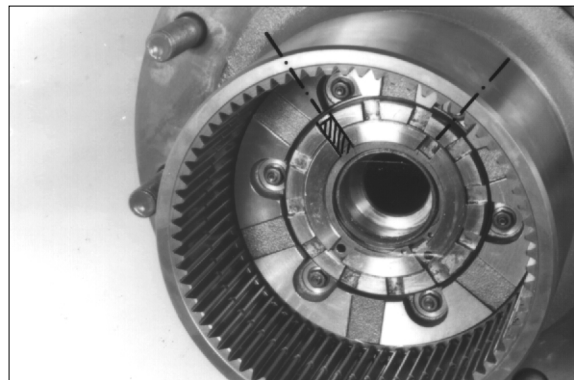

17W78RA057

### Multi disk brake

Required piston stroke : 3.1~3.5mm

The following piston stroke adjustment is only valid for the installation of new plates.

#### Installation instruction:

We know from experience that the required piston stroke is obtained by installation of 5 outer plates with a thickness of  $S = 2.5\text{mm}$  and 1 outer plate with a thickness of  $S = 2.0\text{mm}$ .

In case of exceptions however, a correction may become necessary.

For this case, there are outer plates with a thickness of  $S = 2.0\text{mm}$ ,  $2.5$  and  $3.0\text{mm}$  available.

The following measurement, resp. adjustment is therefore absolutely necessary.

In case of the version with 4 lining plates, the piston stroke is  $2.5\text{-}2.9\text{mm}$ .

The number of lining plates is indicated on the model identification plate(e.g.../5L) or can be taken from the corresponding parts manual.

- (33) Determine dimension I from the end face/ internal gear to the contact surface/piston.  
 · Dimension I e.g. : 90.70mm

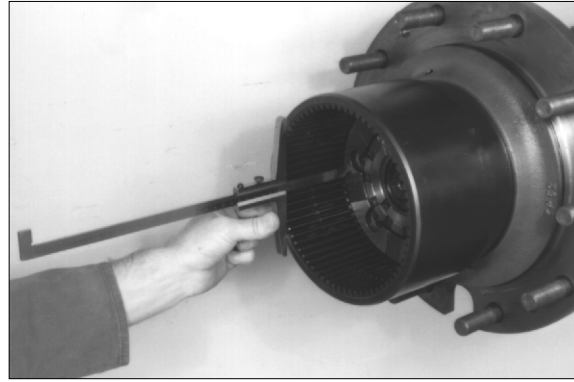

17W78RA058

- (34) Squeeze circlip in and place it on the outer surface of the recess(direction of Arrow) against shoulder.  
 Measure dimension II from the end face/ internal gear to the inner surface of the circlip.  
 · Dimension II e.g. : 46.50mm

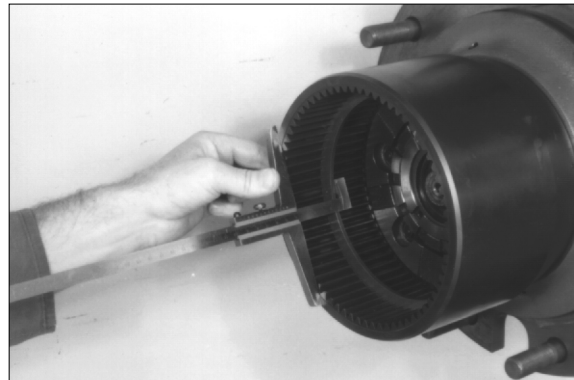

17W78RA059

**Example**

· Dimension I e.g.	90.70mm
· Dimension II e.g.	<u>-46.50mm</u>
· Difference	44.20mm
· Piston stroke max.	3.50mm
min.	3.10mm

Gives installation dimension  
40.70 to 41.10mm

By installation of the following components the required installation dimension, resp. the piston stroke is obtained.

- 5 Lining plates(5, s=3.50mm) = 17.50mm
- 5 Outer plates(5, s=2.50mm) = 12.50mm
- 1 Outer plate(1, s=2.00mm) = 2.00mm
- 1 Backing plate(1, s=9.00mm) = 9.00mm

Gives total height, resp.  
Installation dimension = 41.10mm

- (35) Check the total height of the plate pack again as figure. In case of deviations from the required installation dimension, resp. piston stroke, correct by means of corresponding outer plates  $S = 2.0, 2.5$  or  $3.0\text{mm}$ .

The installation of the thinner outer plate must be always carried out on the piston and or backing plate side.

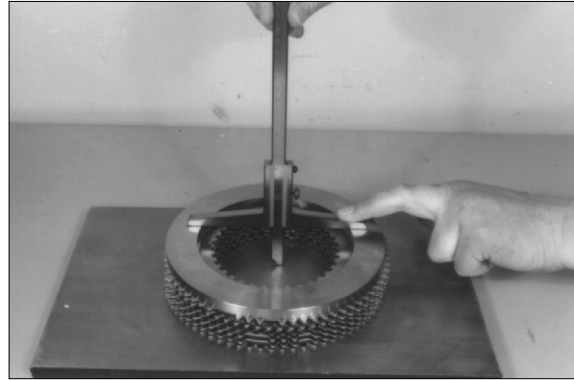

17W78RA060

- (36) Introduce stub shaft into the axle housing until the splines are located in the differential.

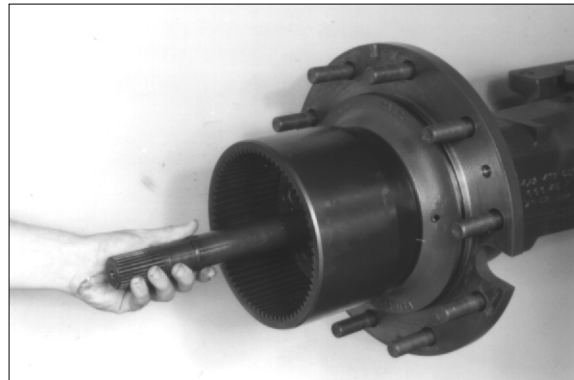

17W78RA061

- (37) Install thrust washer.

To ensure the exact contact, align the two tongues of the thrust washer with the free grooves of the hub carrier.  
Grease contact surface.

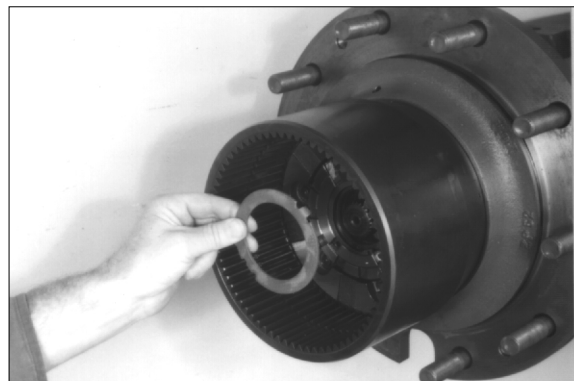

17W78RA062

- (38) Squeeze circlip into the recess of the inner plate carrier.

Grease O-ring and insert it into the annular groove of the inner plate carrier.  
Now, assemble sun-rear shaft until contact is obtained.

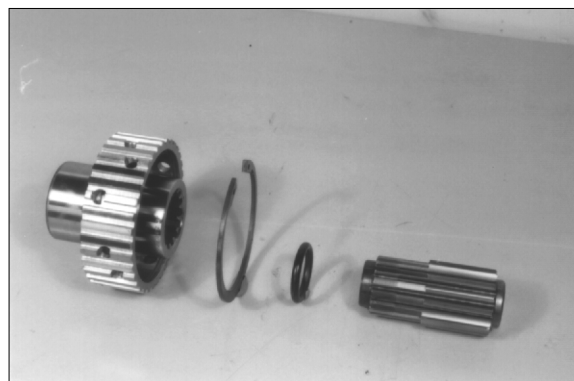

17W78RA063

- (39) Assemble pre-assembled plate carrier until contact is obtained.

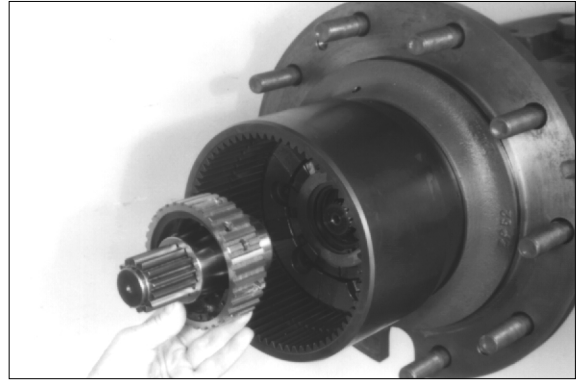

17W78RA064

- (40) Assemble plate pack and backing plate.  
Arrange alternating outer and inner plates, starting with one outer plate.  
Oil plates according to the lubricants.  
Install thinner outer plate on the piston and or backing plate side.



17W78RA065

- (41) Fix plate pack by means of circlip.

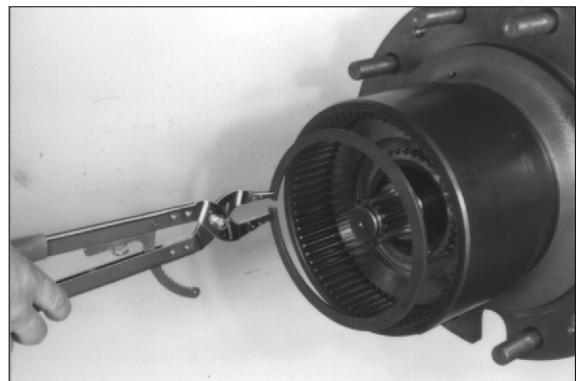

17W78RA066

- (42) Check tightness of brake hydraulic system.

**High pressure test**

Build up test pressure  $p=120\text{bar}$  and close stop valve of the HP-Pump.

During a test period of 5 minutes, a pressure drop of max.2% ( $p=117\text{bar}$ ) is permitted.

**Low pressure test**

Reduce test pressure to  $p=5\text{bar}$ .

Close the stop valve.

During a test period of 5 minutes, no pressure drop is permitted.

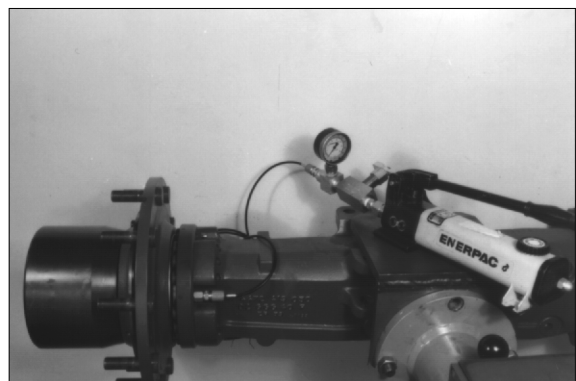

17W78RA067

### Planetary carrier

- (43) Install components according to the as figure.  
Install stepped plane surface of angle rings showing outwards.  
Replace cylindrical rollers in sets only.

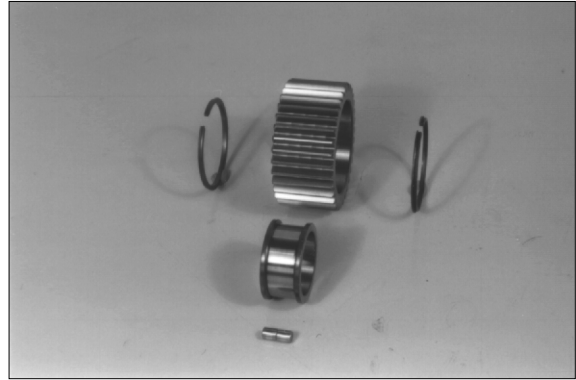

17W78RA068

- (44) Heat bearing inner race and assemble planetary gear until contact is obtained.  
Install large radius of bearing inner race facing the planetary carrier (downwards).



17W78RA069

- (45) Fix planetary gear by means of circlip.  
Install remaining planetary gears correspondingly.



17W78RA070

Adjust and play of sun gear shaft :  
0.3-0.6mm

- (46) Determine Dimension I from the flangemounted surface to the contact surface of the thrust washer.  
· Dimension I e.g. : 199.10mm

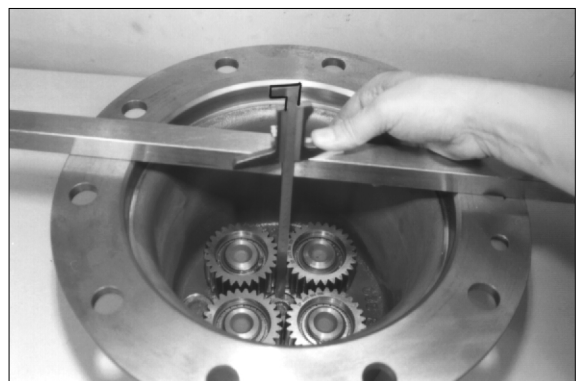

17W78RA071

(47) Insert sun gear until contact is obtained.  
 Measure Dimension II from the end face/  
 sun gear to the flange mounted surface/  
 hub.

· Dimension II e.g. : 196.50mm

**Example**

· Dimension I e.g. 199.10mm

· Dimension II e.g. - 196.50mm

· Difference 2.60mm

· Required end play e.g. - 0.40mm

· Gives thrust washer e.g.  $s = 2.20\text{mm}$

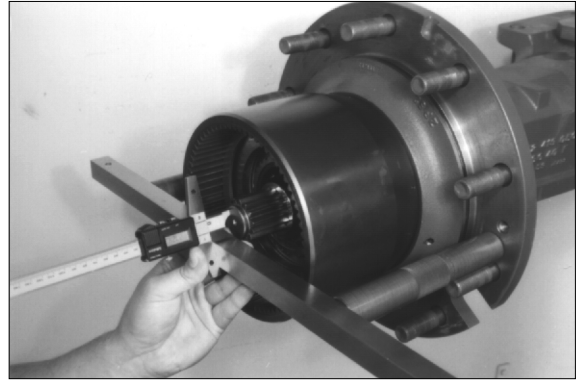

(48) Insert thrust washer into the planetary carrier and press it against shoulder.

If the thrust washer has only a phosphatized surface, this surface must be installed facing the sun gear.

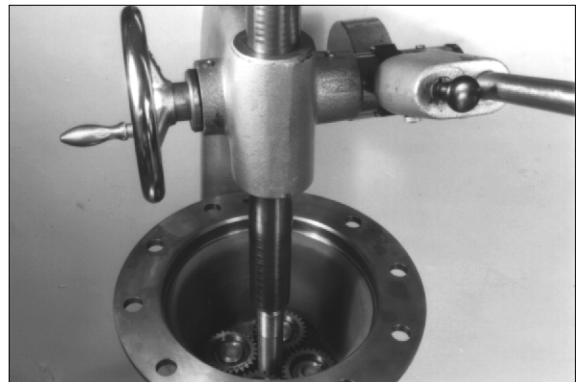
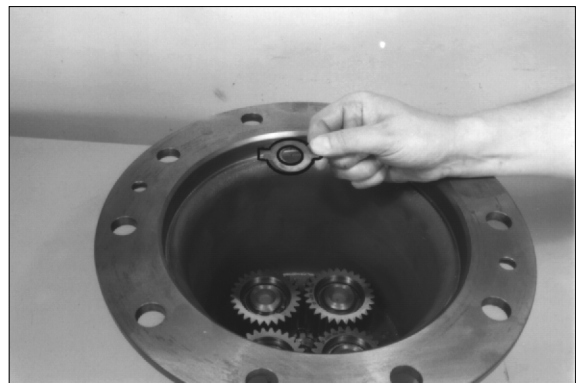

(49) Insert the O-ring into the annular groove of the hub (Arrow) and grease it.

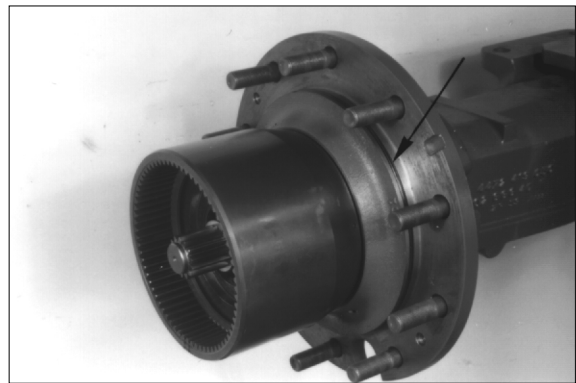

- (50) Assemble the planetary carrier and fasten it by means of both socket head screws.
- Tightening torque : 5.6kgf · m(40.5lb · ft)
- Before the unit is put into service, pay attention to the lubrication and maintenance instructions.

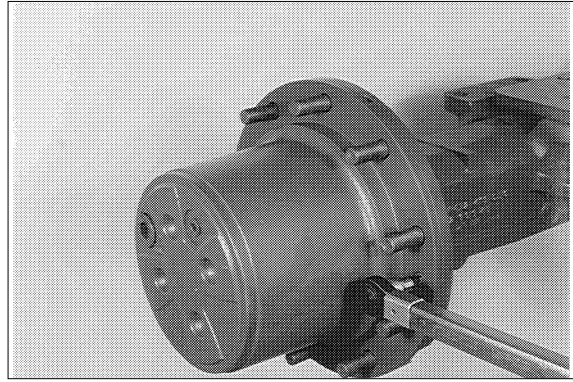

17W78RA076

#### 4. DRIVE UNIT - DIFFERENTIAL -DISASSEMBLY AND ASSEMBLY

##### 1) DISASSEMBLY

###### Remove differential

- (1) Loosen screw plug and drain oil.

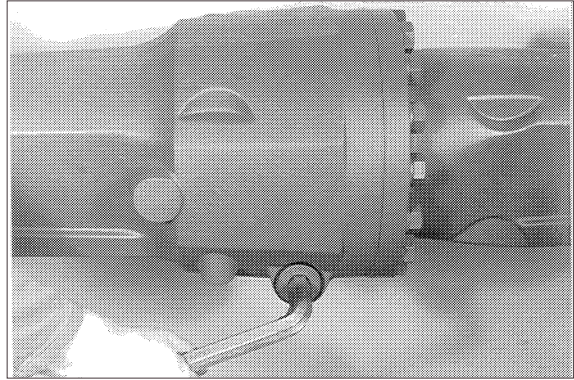

17W78RA077

- (2) Loosen hex. head screws and reamed bolt.  
Mark axle housing I with axle housing II.



17W78RA078

- (3) Separate the axle housing from the axle housing I by means of lifting device.  
If necessary, pay attention to the released differential.

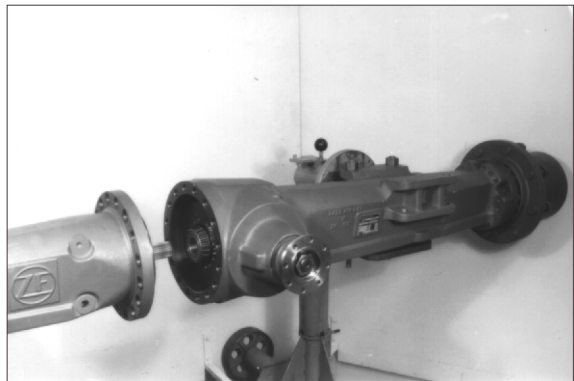

17W78RA079

- (4) Remove differential.

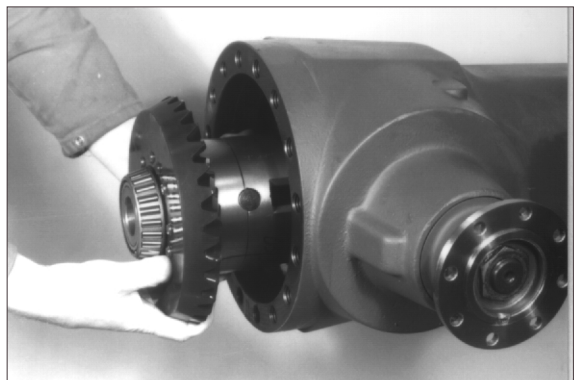

17W78RA080

### Disassemble of differential

- (5) Pull tapered roller bearing from differential case.

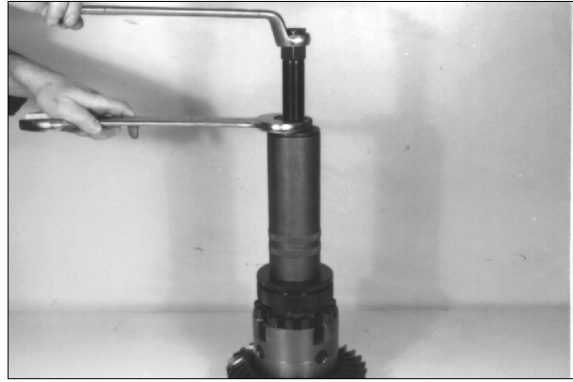

17W78RA081

- (6) Loosen socket head screws and separate differential case halves.

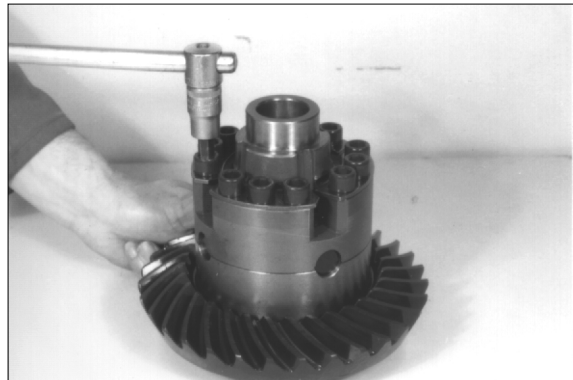

17W78RA082

- (7) Remove components.



17W78RA083

- (8) Pull crown wheel side tapered roller bearing from the differential case.



17W78RA084

(9) Press crown wheel from differential case.

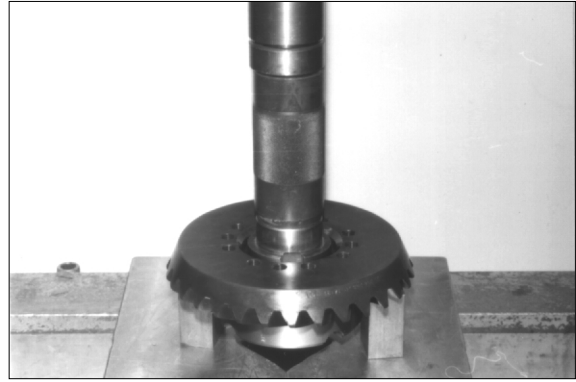

17W78RA085

(10) Pull stub shaft (Arrow) out of the axle housing.  
Remove also second stub shaft.

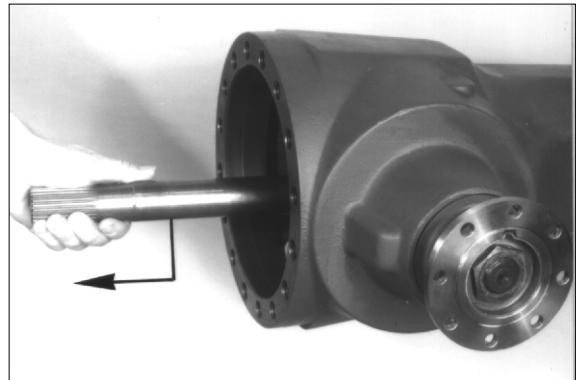

17W78RA086

(11) Pull both bearing outer races (differential bearing) out of the bearing bores of axle housing I and II.  
Pay attention to the released shims.

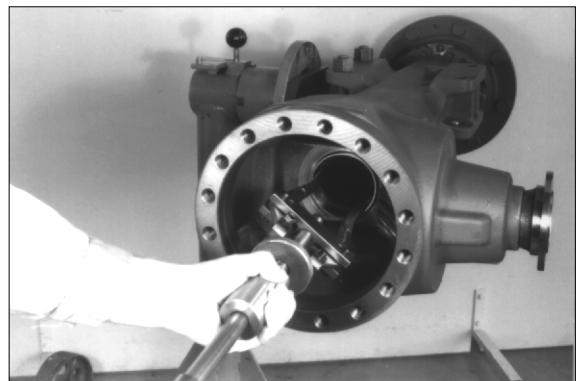

17W78RA087

**Remove drive pinion**  
(12) Remove lock plate.

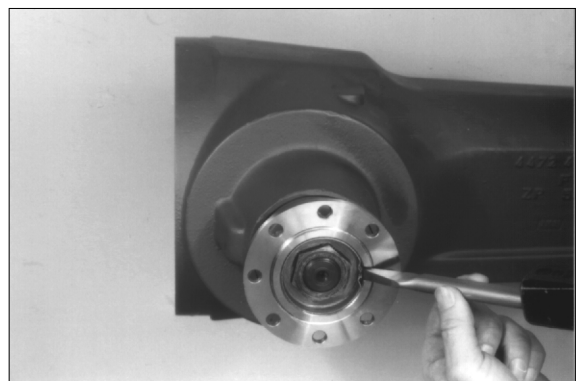

17W78RA088

(13) Loosen hex nut.

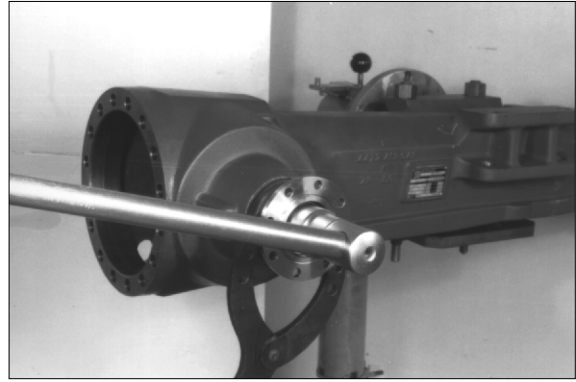

17W78RA089

(14) Pull off drive flange.

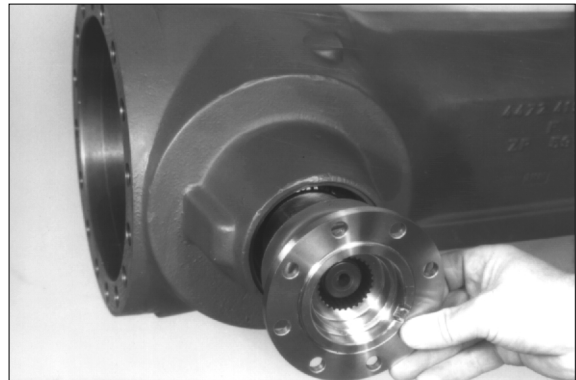

17W78RA090

(15) Remove drive pinion.

If the pinion bearing must not be renewed pay attention that at the driving out of the drive pinion, the outer bearing inner race has always contact on the bearing outer race.

If this is not the case, the bearing would be damaged and must therefore be renewed.

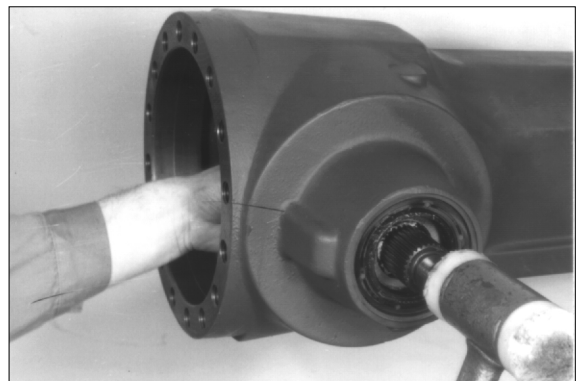

17W78RA091

(16) Remove the spacer and pull the tapered roller bearing from the drive pinion.



17W78RA092

(17) Remove the shaft seal and the released tapered roller bearing.

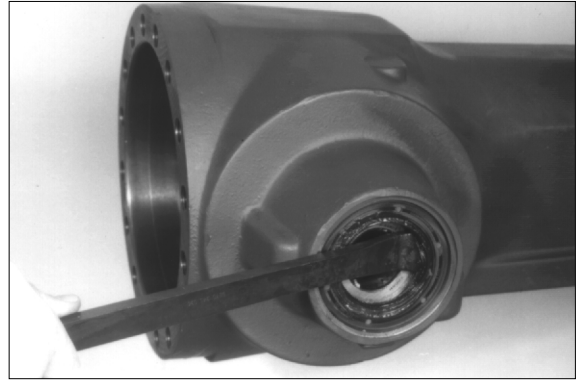

17W78RA093

(18) Drive bearing outer race out of the inner bearing bore.  
Pay attention to the released spacing washer.

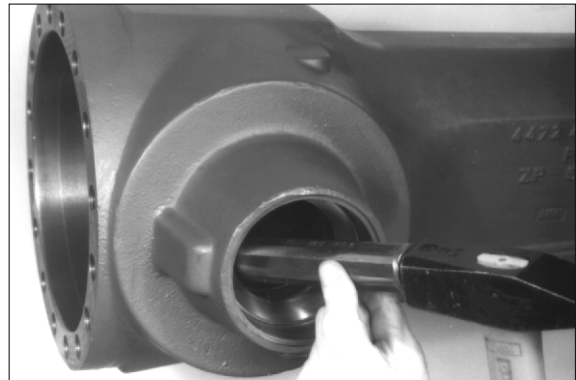

17W78RA094

(19) Pull bearing outer race out of the outer bearing bore.

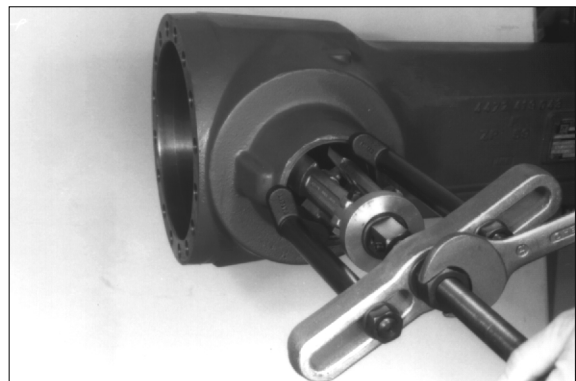

17W78RA095

## 2) REASSEMBLY

### Drive pinion

If crown wheel or drive pinion are damaged, both parts must be renewed as a set. If a new complete crown wheel set is installed, pay attention that crown wheel and drive pinion have the same mating numbers.

If crown wheel set or axle housing are renewed, pay attention to the Draft.

Determine shim thickness to obtain a correct contact pattern following (2) to Example "H".

Carry out the following measuring operations with utmost care.

Inexact measurements result in a faulty contact pattern-another correction on the installed drive pinion becomes necessary.

#### (1) Reference Draft(special tool)

- 1 Dimension and No. of drive pinion
- 2 Measuring shaft
- 3 Adjusting piece
- 4 Shim
- 5 Gauge ring
- 6 Measuring cover, Centering ring

For a better understanding of the Draft, the measuring operation is illustrated again in steps.

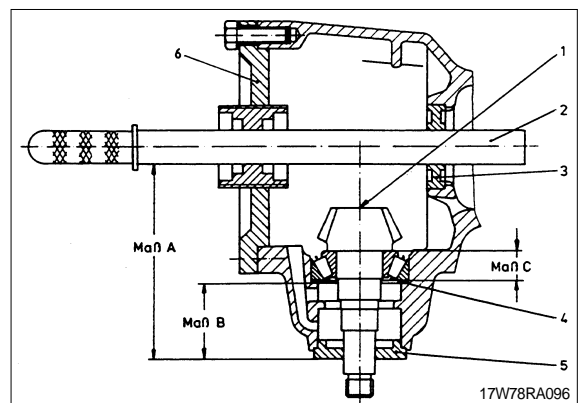

#### (2) Insert adjusting piece(3) into the bore of the axle housing I(differential bearing).

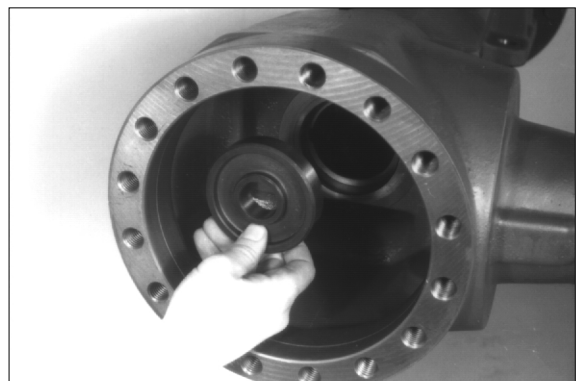

- (3) Mount measuring cover(6) and fasten it by means of hex head screws.  
Introduce measuring shaft(2) until it is located in the bore of adjusting piece(3).

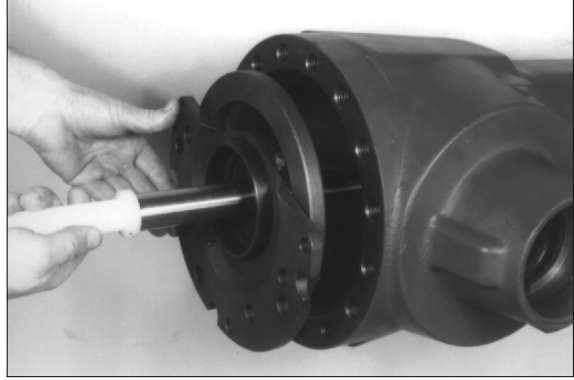

17W78RA098

- (4) Place gauge ring(5) on the machined plane surface of the housing neck against shoulder.  
Determine Dimension A as figure.  
· Dimension A e.g. : 208.80mm

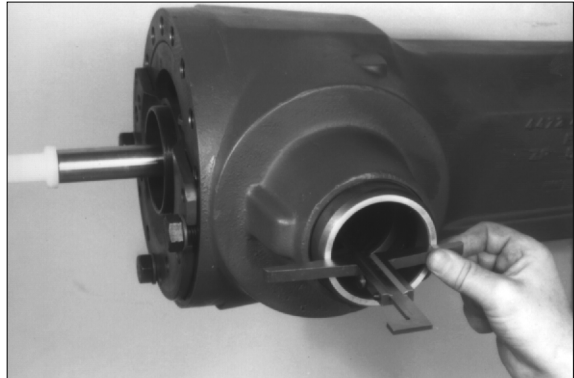

17W78RA099

- (5) Measure dimension B from the plane surface/gauge ring(5) to the contact surface of the inner bearing outer race as figure.  
· Dimension B e.g. : 78.70mm

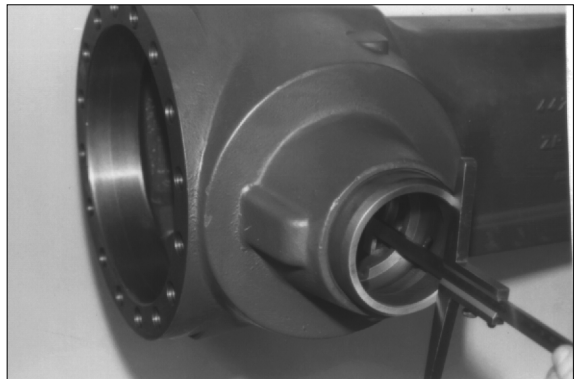

17W78RA100

- (6) Determine dimension C (bearing width).  
· Dimension C e.g. : 31.95mm

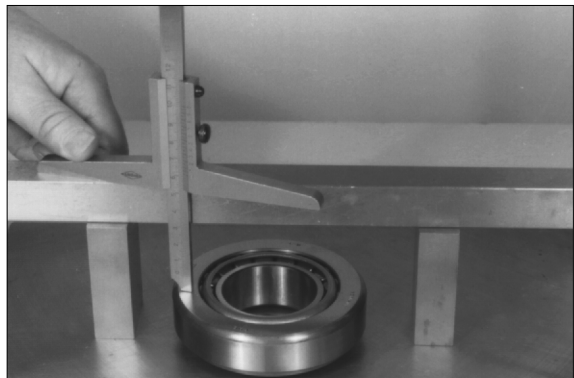

17W78RA101

- (7) Read pinion dimension(1).  
 · e.g.  $112.0^{+0.05}$  : 112.05mm

**Example E**

· Dimension A	208.80mm
· $1/2\varnothing$ measuring shaft	<u>+15.00mm</u>
· Gives dimension X	223.80mm

**Example F**

· Dimension X	223.80mm
· Dimension B	<u>-78.70mm</u>
· Gives dimension Y	145.10mm

**Example G**

· Dimension C(bearing width)	31.95mm
· Pinion dimension	<u>+112.05mm</u>
· Dimension Z	144.00mm

**Example H**

· Dimension Y	145.10mm
· Dimension Z	<u>-144.00mm</u>
· Difference shim	<u>s = 1.10mm</u>

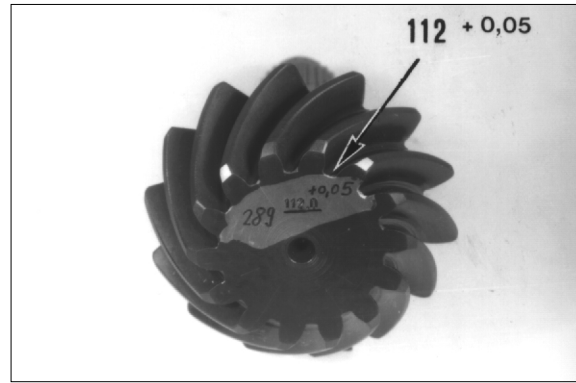

17W78RA102

- (8) Insert determined shim e.g.  $s = 1.10\text{mm}$  into the bearing bore.

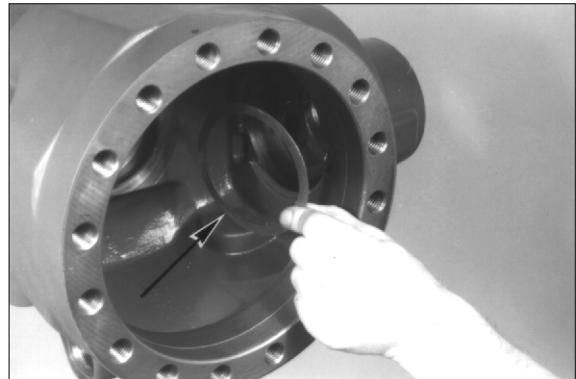

17W78RA103

- (9) Undercool bearing outer race(Arrow) and place it against shoulder, using special device.

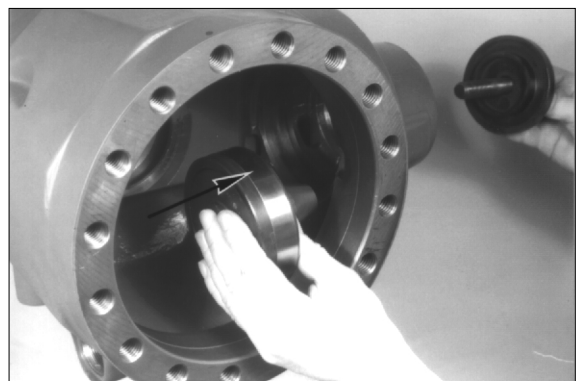

17W78RA104

- (10) Undercool second bearing outer race and insert it until contact is obtained.

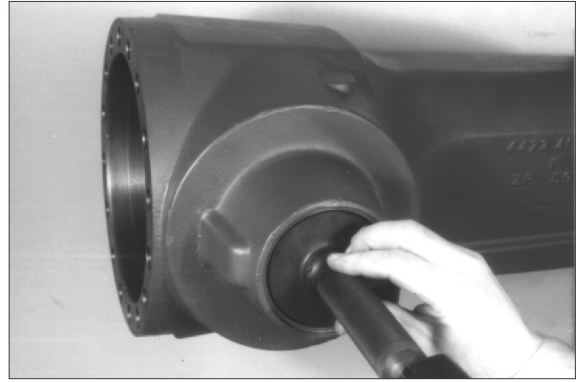

17W78RA105

- (11) Heat tapered roller bearing and place it against shoulder.  
Reset the bearing after the cooling down.

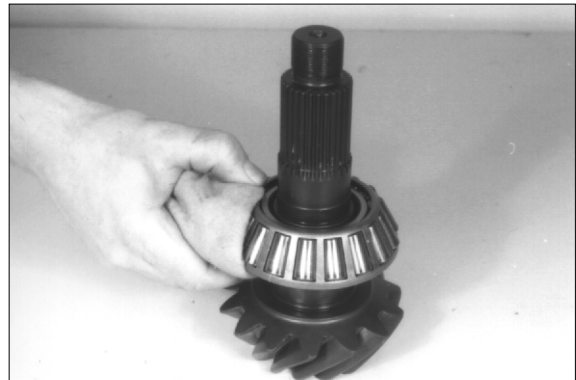

17W78RA106

**Adjust rolling moment of the drive pinion bearing(without shaft seal) following (13) to (20) : 0.1-0.2kg · m(0.7-1.4lb · ft)**

- (12) Lay gauge ring upon the collar of the drive pinion.



17W78RA107

Shape and description of the gauge ring.

- 1 Ring
- 2 Roll pins(3EA)

Drive roll pins amply out of the bores of the gauge ring so that the roll pins can be passed back at the tightening of the hex nut, thus realizing a correct measuring result.

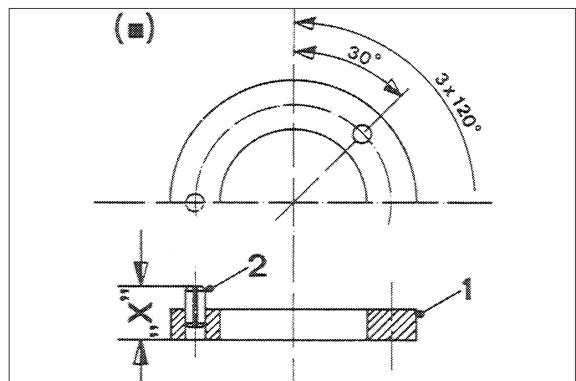

17W78RA108

- (13) Position drive pinion and assemble heated bearing inner race.



17W78RA109

- (14) Install drive flange, assemble disk and tighten hex nut until the required rolling moment of 0.1-0.2kgf · m is obtained. Check rolling moment again as figure. During the tightening, turn the drive pinion several times through in both directions.



17W78RA110

- (15) Remove drive pinion again.  
To prevent a damage of the pinion bearing, pay attention that at the driving out of the drive pinion the outer bearing inner race has always contact on the bearing outer race.

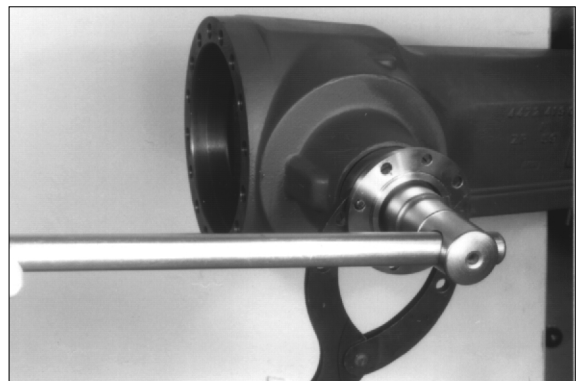

17W78RA111

- (16) Remove gauge ring and determine Dimension X as previous page.  
· Dimension X e.g. : 11.36mm  
Dimension X corresponds to the thickness of the spacer to be installed.



17W78RA112

- (17) Assemble the corresponding spacer(e.g. 11.36mm), see Arrow.

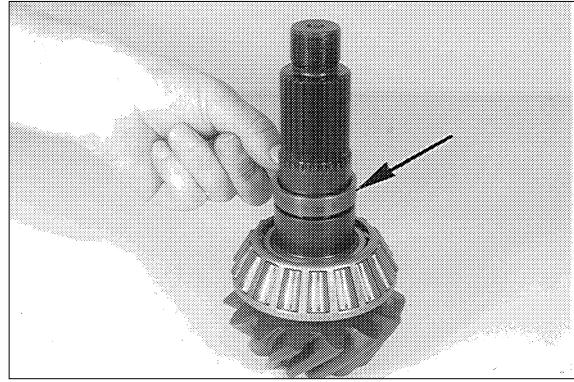

17W78RA113

- (18) Install pinion again and assemble the drive flange.

Mount disk and tighten hex nut.

- Tightening torque : 43.8kgf · m  
(317.1lb · ft)

During the tightening, turn the drive pinion several time through in both directions.

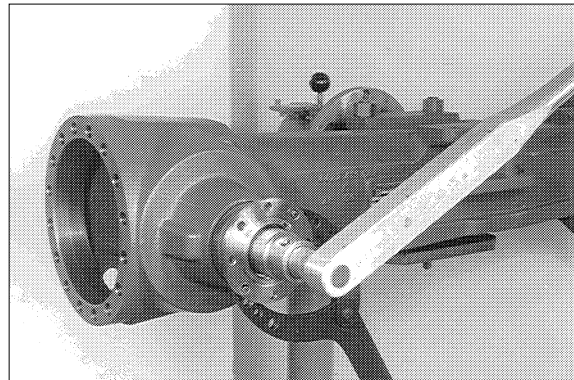

17W78RA114

- (19) Check rolling moment again.

- Rolling moment : 0.1-0.2kg · m  
(0.7-1.4lb · ft)

In case of deviations from the required rolling moment, correct again by means of a corresponding ring.

Now, loosen hex nut again and pull off drive flange.

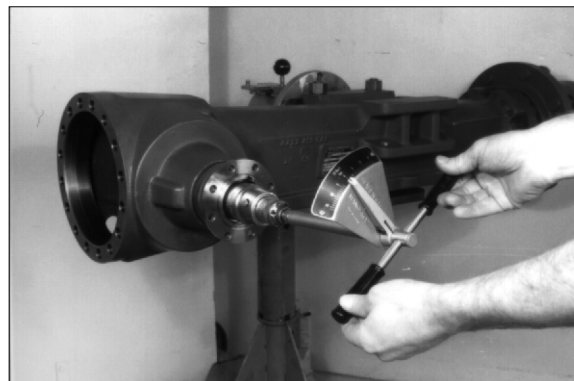

17W78RA115

- (20) Install shaft seal.

By application of the prescribed driver, the exact installation position is obtained.

If the outer diameter of the shaft seal is rubber-coated, wet the sealing surface with spirit.

If not, use sealing compound(loctite type No. 586).

Fill cavity between sealing lip and dust lip with grease.

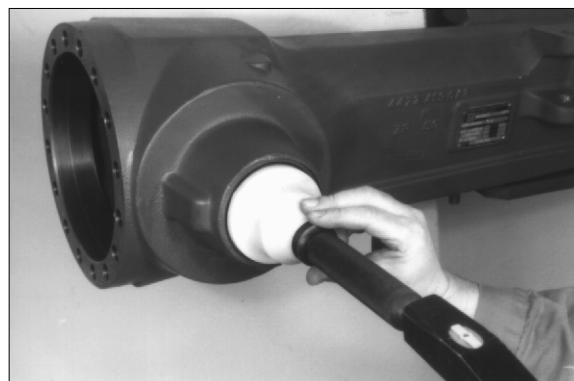

17W78RA116

(21) If necessary, insert hex head screws into the bores of the drive flange (according to the Version) and press dust plate against shoulder until contact is obtained.

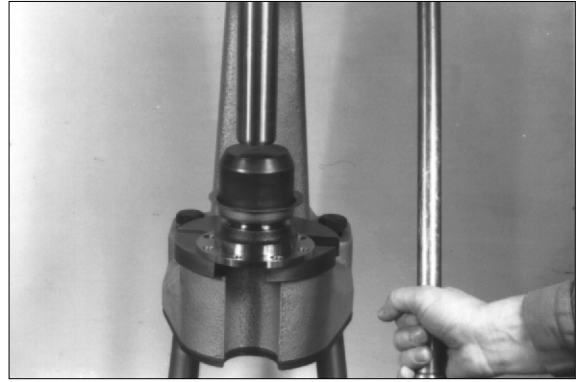

17W78RA117

(22) Assemble drive flange and fasten it finally by means of disk and hex nut.  
· Tightening torque : 43.8kgf · m  
(317.1lb · ft)

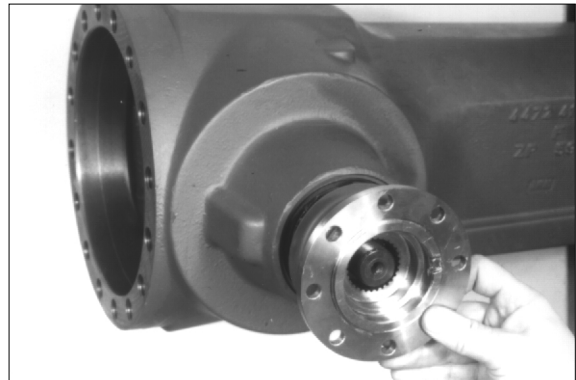

17W78RA118

### **Complete and install differential**

Before the installation, oil all differential components.

(23) Drive roll pins (2 pieces each/bore) into the blind holes of the differential case half. Install roll pin openings always in the circumferential direction and 180° spaced.



17W78RA119

(24) Press crown wheel over the roll pins until contact is obtained.

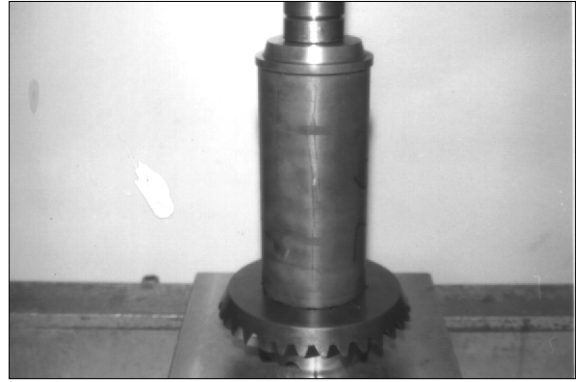

17W78RA120

(25) Install thrust washer and side gear.



17W78RA121

(26) Install complete differential spider.  
Pay attention to the radial installation position of the thrust washer-noses are showing upward, see Arrow.  
Now, mount 2nd side gear.



17W78RA122

(27) Make thrust washers adhere with grease in the differential case half II.  
Mount differential case half.  
Pay attention to the radial installation position, see designation(ZP-No.).

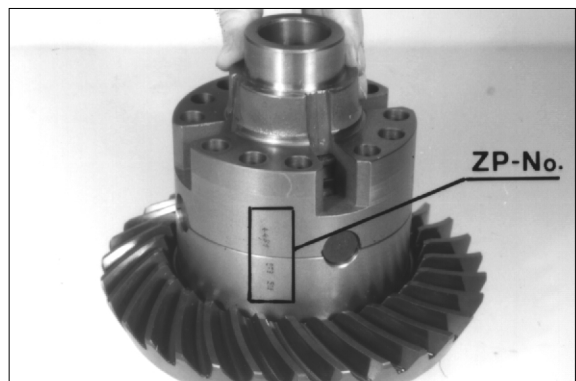

17W78RA123

- (28) Mount flat washers and tighten the socket head screws(M12 × 1.5).  
· Tightening torque : 14.8kgf · m(107lb · ft)

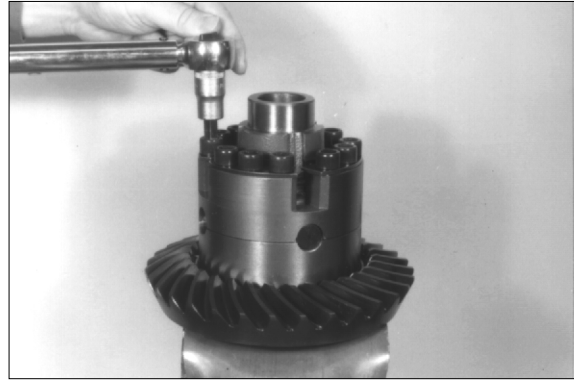

17W78RA124

- (29) Heat both bearing inner races and place them against shoulder.

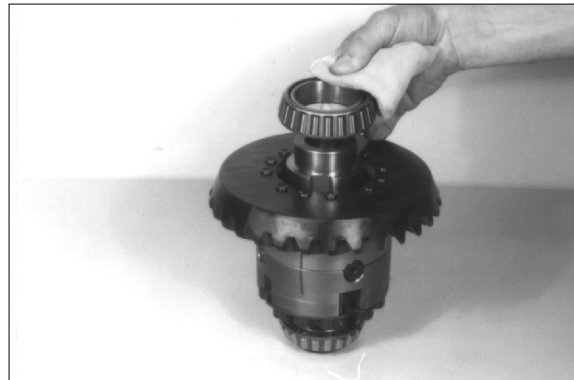

17W78RA125

**Adjust backlash of the crown wheel set and bearing preload of differential.  
(Example I)**

- Backlash : 0.15~0.25mm
  - Bearing rolling moment : 0.1-0.4kgf · m  
(0.7-2.9lb · ft)
- (30) Insert shim e.g.  $s = 1.70\text{mm}$ (empirical value) into the bearing bore and install subsequently bearing outer race.

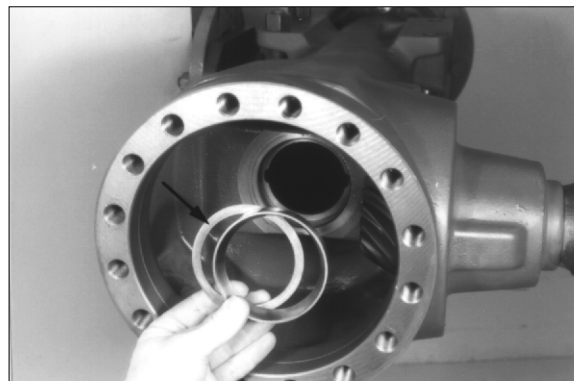

17W78RA126

- (31) Insert crown wheel side bearing outer race into the measuring device.

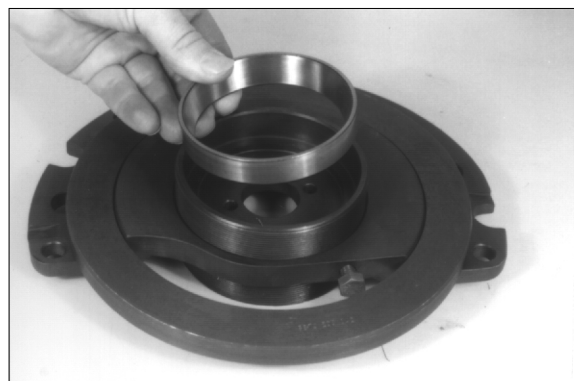

17W78RA127

(32) Insert the differential into the axle housing and fix it by means of measuring cover.

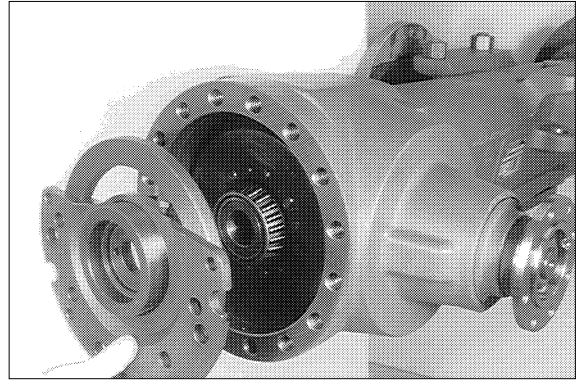

17W78RA128

(33) Fasten the special device by means of hex head screws.

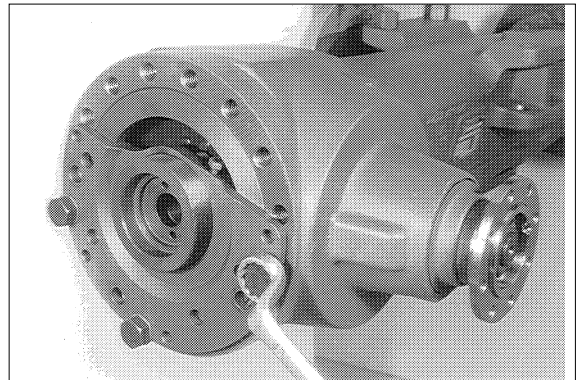

17W78RA129

(34) Adjust the differential without play and pressure by application of the threaded spindle.  
Now, fix the threaded spindle by means of locking screw (Arrow).

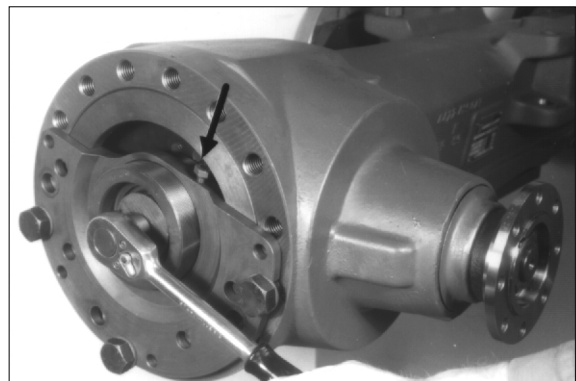

17W78RA130

(35) Apply dial indicator through the oil drain hole right-angled on the crown wheel tooth flank and check the backlash.  
In case of a deviation from the required backlash, correct by means of corresponding shim.



17W78RA131

(36) After the backlash adjustment, remove the measuring device. Remove bearing outer race.

Determine Dimension I from the flange-mounted surface to the contact surface/ bearing outer race.

- Dimension I e.g. : 16.90mm

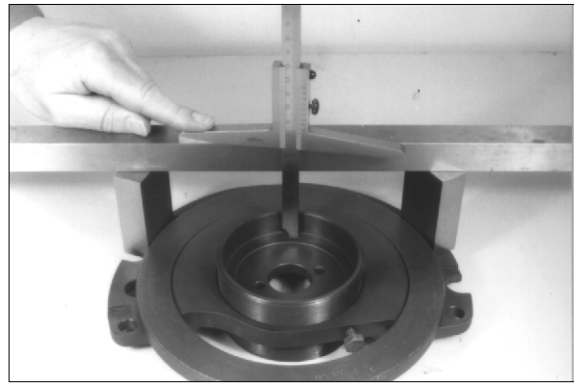

17W78RA132

(37) Measure Dimension II from the flange-mounted surface of the axle housing to the contact surface/bearing outer race.

- Dimension II e.g. : 14.00mm

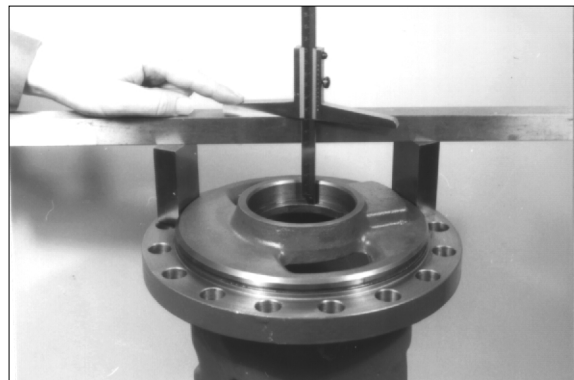

17W78RA133

### Example I

· Dimension I	16.90mm
· Dimension II	<u>-14.00mm</u>
· Difference	2.90mm
· Required bearing preload	<u>+0.10</u>
· Gives shim	<u>s = 3.00mm</u>

With a bearing preload of 0.1mm, the required bearing rolling moment 0.1-0.4kgf · m(0.7-2.9lb · ft) is obtained.

(38) Insert determined shim e.g. 3.0mm into the bearing bore of the axle housing II and install subsequently bearing outer race until contact is obtained.



17W78RA134

### Check contact pattern

(39) Wet some crown wheel tooth flanks with gear-marking compound and insert the differential into the axle housing.

Fasten the axle housing II Provisionally on axle housing I by means of some hex head screws.

Now, roll the crown wheel several times to and fro over the drive pinion.

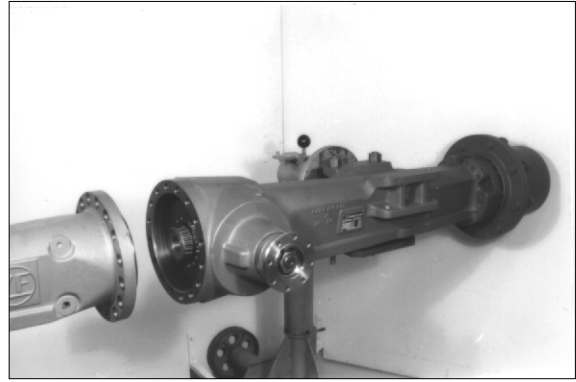

17W78RA135

(40) Remove differential again and compare the obtained contact pattern with the Examples of contact patterns.

In case of a greater contact pattern deviation, a measuring error has been made at the determination of the shim which must be absolutely corrected.

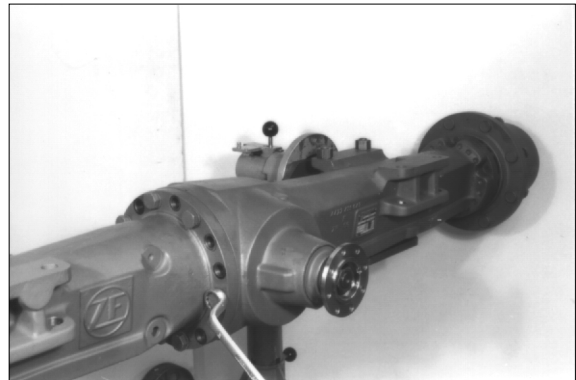

17W78RA136

(41) Introduce stub shaft into the inner plate carrier until contact is obtained and install the differential.

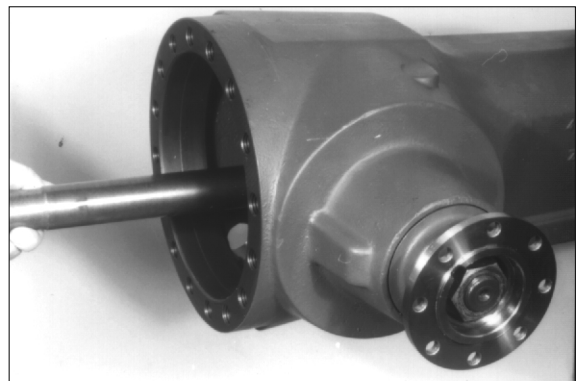

17W78RA137

(42) Insert O-ring (Arrow) into the annular groove of axle housing and grease it.



17W78RA138

- (43) Introduce second stub shaft (Arrow) into axle housing II until contact is obtained. Now, install two adjusting screws and position axle housing II against shoulder. Pay attention to the installation position.

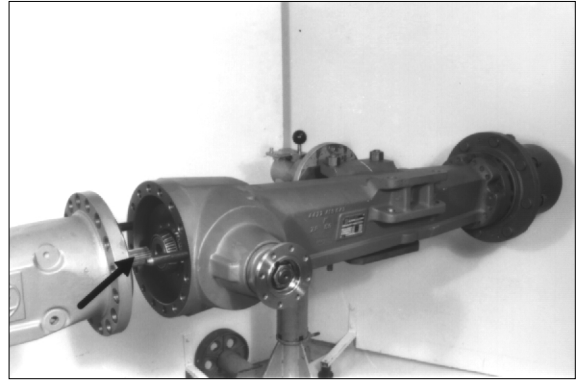

17W78RA139

- (44) Fasten axle housing II by means of disks and hex head screws. Pay attention to the installation position of the reamed bolt (M18), see Arrow.
- Tightening torque : 39.8kgf · m  
(287.6lb · ft)

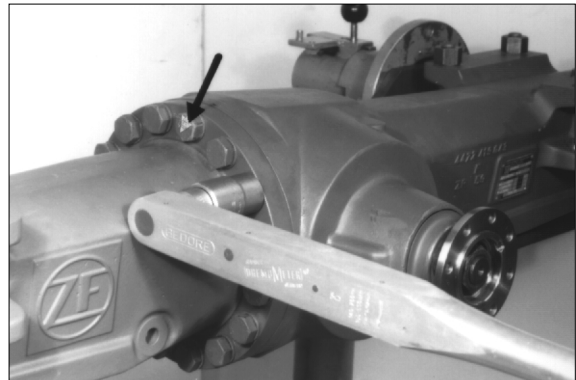

17W78RA140

- (45) Fix hex nut by means of lock plate. Caulk lock plate on the drive flange. Before the axle is put into service, pay attention to the lubrication and maintenance instructions.

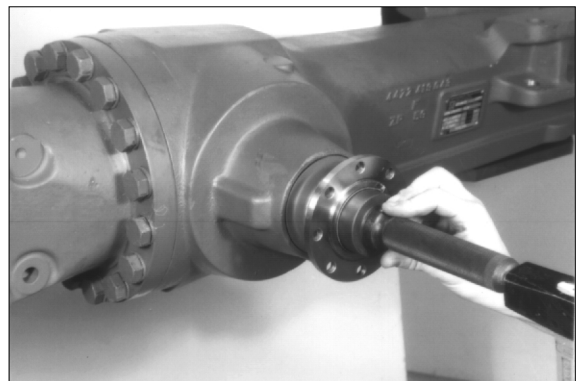

17W78RA141