

GROUP 2 MAJOR COMPONENT

1. MAIN PUMP

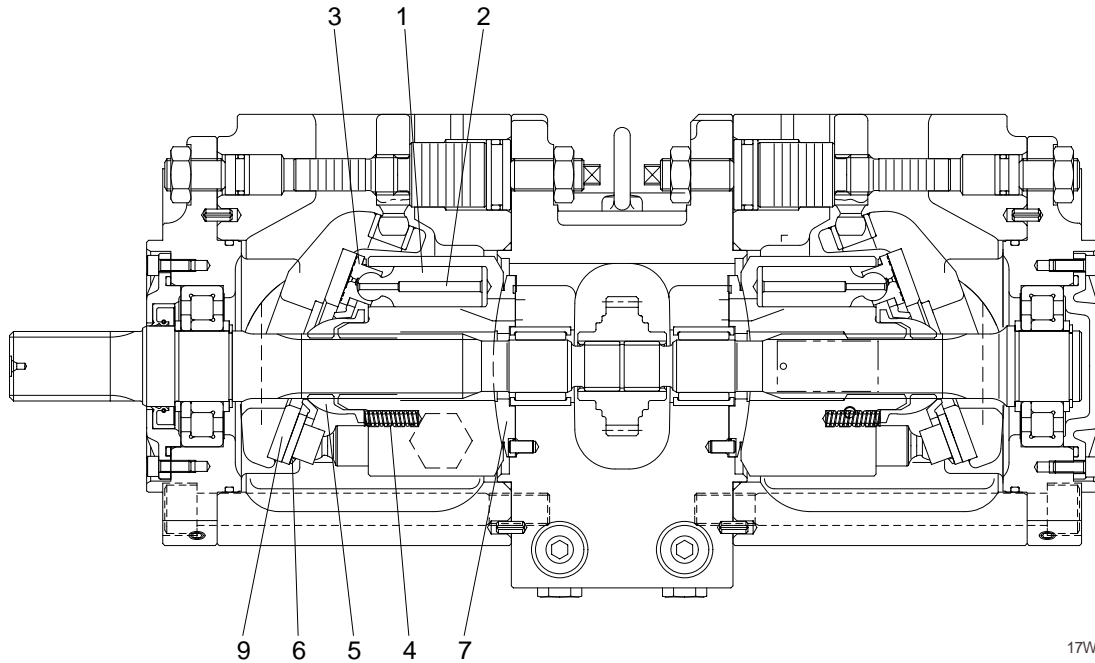

17W77MS12

| Part name & inspection item | | Standard dimension | Recommended replacement value | Counter measures |
|--|--|--------------------|-------------------------------|-----------------------------------|
| Clearance between piston(1) & cylinder bore(2) (D-d) | | 0.028 | 0.056 | Replace piston or cylinder |
| Play between piston(1) & shoe caulking section(3) () | | 0-0.1 | 0.3 | Replace assembly of piston & shoe |
| Thickness of shoe (t) | | 3.9 | 3.7 | |
| Free height of cylinder spring(4) (L) | | 31.3 | 30.5 | Replace cylinder spring |
| Combined height of set plate(H) & spherical bushing(5)(h) (H-h) | | 19.0 | 18.3 | Replace retainer or set plate |
| Surface roughness for valve plate(Sliding face) (7,8), swash plate(Shoe plate area)(9), & cylinder(2) (Sliding face) | Surface roughness necessary to be corrected | 3z | | Lapping |
| | Standard surface roughness (Corrected value) | 0.4z or lower | | |

2. MAIN CONTROL VALVE

| Part name | Inspection item | Criteria & measure |
|--|---|---|
| Casing | <ul style="list-style-type: none"> · Existence of scratch, rusting or corrosion | <ul style="list-style-type: none"> · In case of damage in following section, replace part. <ul style="list-style-type: none"> - Sliding sections of casing fore and spool, especially land sections applied with holded pressure. - Seal pocket section where spool is inserted. - Seal section of port where O-ring contacts. - Seal section of each relief valve for main, travel, and port. - Other damages that may damage normal functions. |
| Spool | <ul style="list-style-type: none"> · Existence of scratch, gnawing, rusting or corrosion. · O-ring seal sections at both ends. · Insert spool in casing hole, rotate and reciprocate it. | <ul style="list-style-type: none"> · Replacement when its outside sliding section has scratch(Especially on seals-contacting section). · Replacement when its sliding section has scratch. · Correction or replacement when O-ring is damaged or when spool does not move smoothly. |
| Poppet | <ul style="list-style-type: none"> · Damage of poppet or spring. · Insert poppet into casing and function it. | <ul style="list-style-type: none"> · Correction or replacement when sealing is incomplete. · Normal when it can function lightly without being caught. |
| Around spring | <ul style="list-style-type: none"> · Rusting, corrosion, deformation or breaking of spring, spring seat, plug or cover. | <ul style="list-style-type: none"> · Replacement for significant damage. |
| Around seal for spool | <ul style="list-style-type: none"> · External oil leakage · Rusting, corrosion or deformation of seal plate | <ul style="list-style-type: none"> · Correction or replacement · Correction or replacement |
| Main relief valve, port relief valve & negative control relief valve | <ul style="list-style-type: none"> · External rusting or damage · Contacting face of valve seat · Contacting face of poppet · Abnormal spring · O-rings, back up rings and seals | <ul style="list-style-type: none"> · Replacement · Replacement when damaged · Replacement when damaged · Replacement · 100% replacement in general |

3. SWING MOTOR

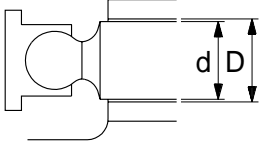
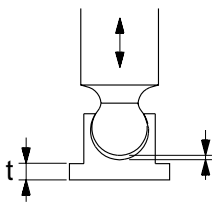
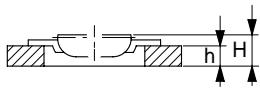
| Part name & inspection item | | Standard dimension | Recommended replacement value | Counter measures |
|--|---|--------------------|-------------------------------|------------------------------------|
| Clearance between piston & cylinder bore (D-d) |  | 0.028 | 0.058 | Replace piston or cylinder. |
| Play between piston & shoe caulking section () |  | 0 | 0.3 | Replace assembly of piston & shoe. |
| Thickness of shoe (t) | | 5.5 | 5.3 | |
| Combined height of set plate(H) & spherical bushing(h) (H-h) |  | 6.5 | 6.0 | Replace retainer or set plate. |
| Friction plate | - | 4.0 | 3.6 | Replace |

SURFACE ROUGHNESS

| Item | Standard Surface roughness (correct value) | Surface roughness to be corrected | Counter measures |
|-------------|--|-----------------------------------|------------------|
| Shoe | 0.8z | 3z | Lapping |
| Shoe plate | 0.4z | 3z | Lapping |
| Cylinder | 1.6z | 12.5z | Lapping |
| Valve plate | 0.8z | 6.3z | Lapping |

4. TRAVEL MOTOR

- 1) Free of corrosion, erosion or fretting; no damage to splines or keyways.

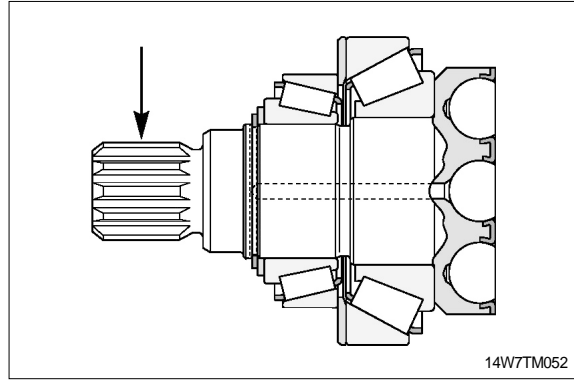

- 2) Pistons
No scoring and no pittings.

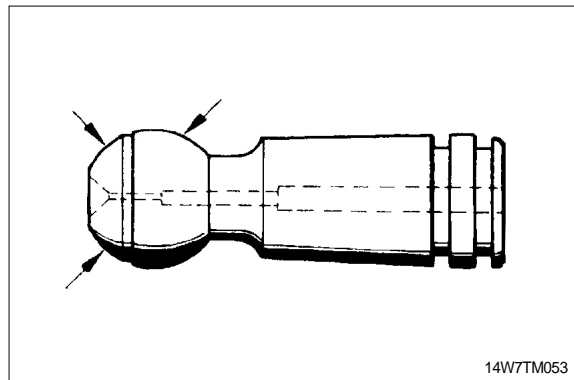

- 3) Center pin
No scoring and no pittings.

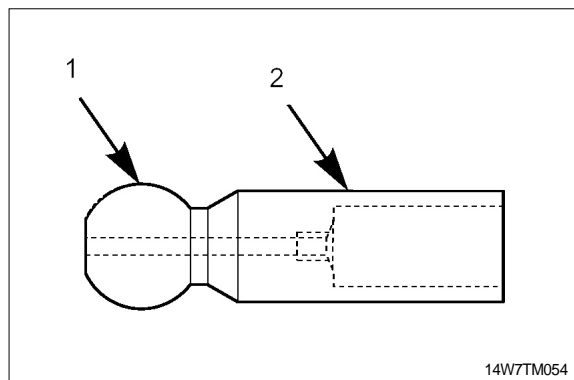

- 4) Retaining plate
No scoring and no evidence of wear.

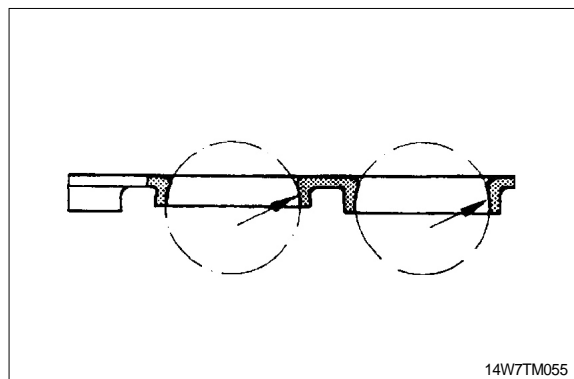

5) Cylinder block/control lens

Bores free of scoring, no evidence of wear.

Faces smooth and even, free of cracks and scoring.

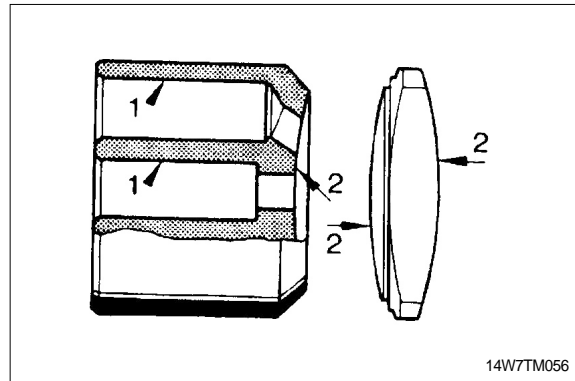

6) Control housing

Sliding surface and side guides free of scoring and no wear.

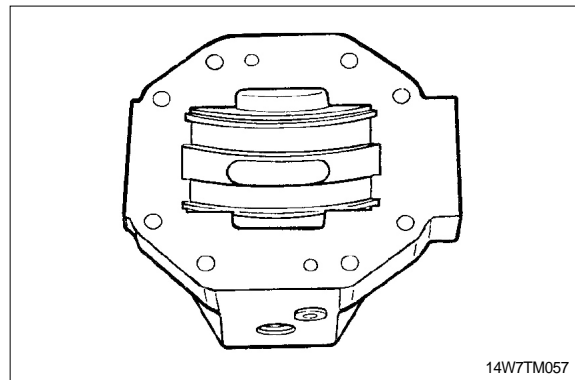

7) Visual check

Bearing areas free of scoring and no evidence of wear.

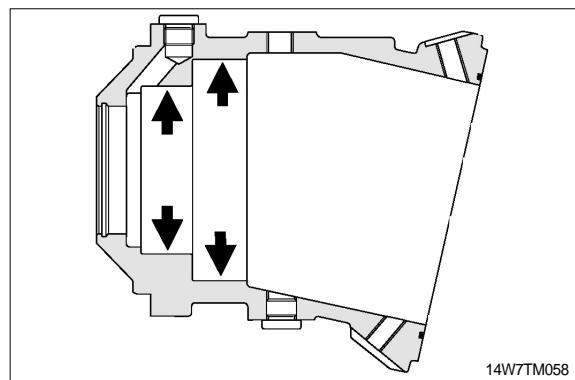

5. RCV LEVER

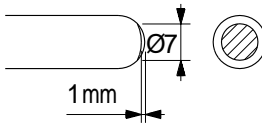
| Maintenance check item | Criteria | Remark |
|---------------------------|---|---|
| Leakage | The valve is to be replaced when the leakage becomes more than 1000cc/m at neutral handle position, or more than 2000cc/m during operation. | Conditions : Primary pressure : 30kgf/cm ² Oil viscosity : 23cSt |
| Spool | This is to be replaced when the sliding surface has worn more than 10 μm, compared with the non-sliding surface. | The leakage at the left condition is estimated to be nearly equal to the above leakage. |
| Push rod |  <p>This is to be replaced when the top end has worn more than 1mm.</p> | |
| Play at operating section | The pin, shaft, and joint of the operating section are to be replaced when their plays become more than 2mm due to wears or so on. | When a play is due to looseness of a tightened section, adjust it. |
| Operation stability | When abnormal noises, hunting, primary pressure drop, etc. are generated during operation, and these cannot be remedied, referring to section 6 troubleshooting, replace the related parts. | |

- Notes
1. It is desirable to replace seal materials, such as O-rings, every disassembling. However, they may be reused, after being confirmed to be free of damage.
 2. When loosening the hexagon socket head cap screw(125), replace the seal washers(121) without fail.

6. ACCELERATOR PEDAL

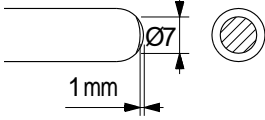
| Maintenance check item | Criteria | Remark |
|---------------------------|---|---|
| Leakage | The valve is to be replaced when the leakage effect to the system. For example, the primary pressure drop. | Conditions : Primary pressure : 30kgf/cm ² Oil viscosity : 23cSt |
| Spool | This is to be replaced when the sliding surface has worn more than 10 μm, compared with the non-sliding surface. | The leakage at the left condition is estimated to be nearly equal to the above leakage. |
| Push rod |  <p>This is to be replaced when the top end has worn more than 1mm.</p> | |
| Play at operating section | The pin, shaft, and joint of the operating section are to be replaced when their plays become more than 2mm due to wears or so on. | When a play is due to looseness of a tightened section, adjust it. |
| Operation stability | When abnormal noises, hunting, primary pressure drop, etc. are generated during operation, and these cannot be remedied, referring to section 6 troubleshooting, replace the related parts. | |

Notes 1. It is desirable to replace seal materials, such as O-rings, every disassembling. However, they may be reused, after being confirmed to be free of damage.

7. TURNING JOINT

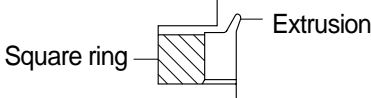
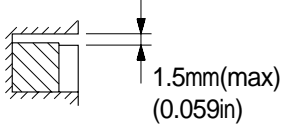
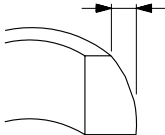
| Part name | | Maintenance standards | Remedy |
|---------------|--|--|----------------------|
| Body, Stem | Sliding surface with sealing sections | Plating worn or peeled due to seizure or contamination | Replace |
| | Sliding surface between body and stem other than sealing section | · Worn abnormality or damaged more than 0.1mm (0.0039in) in depth due to seizure contamination | Replace |
| | | · Damaged more than 0.1mm(0.0039in) in depth | Smooth with oilstone |
| | Sliding surface with thrust plate | · Worn more than 0.5mm(0.02in) or abnormality | Replace |
| | | · Worn less than 0.5mm(0.02in) | Smooth |
| | | · Damage due to seizure or contamination remediable within wear limit (0.5mm)(0.02in) | Smooth |
| Cover | Sliding surface with thrust plate | · Worn more than 0.5mm(0.02in) or abnormality | Replace |
| | | · Worn less than 0.5mm (0.02in) | Smooth |
| | | · Damage due to seizure or contamination remediable within wear limit (0.5mm)(0.02in) | |
| Seal set | - | <ul style="list-style-type: none"> · Extruded excessively from seal groove square ring  | Replace |
| | - | <ul style="list-style-type: none"> · Slipper ring 1.5mm(0.059in) narrower than seal groove, or narrower than back ring  | Replace |
| | - | <ul style="list-style-type: none"> · Worn more than 0.5mm(0.02in) ~ 1.5mm(MAX) (0.059in)  | Replace |

8. CYLINDER

| Part name | Inspecting section | Inspection item | Remedy |
|---------------|--|---|---|
| Piston rod | · Neck of rod pin | · Presence of crack | · Replace |
| | · Weld on rod hub | · Presence of crack | · Replace |
| | · Stepped part to which piston is attached | · Presence of crack | · Replace |
| | · Threads | · Presence of crack | · Recondition or replace |
| | · Plated surface | · Plating is not worn off to base metal | · Replace or replate |
| | | · Rust is not present on plating · Scratches are not present | · Replace or replate · Recondition, replate or replace |
| · Rod | · Wear of O.D. | · Recondition, replate or replace | |
| Cylinder tube | · Bushing at mounting part | · Wear of I.D. | · Replace |
| | · Weld on bottom | · Presence of crack | · Replace |
| | · Weld on head | · Presence of crack | · Replace |
| | · Weld on hub | · Presence of crack | · Replace |
| | · Tube interior | · Presence of faults | · Replace if oil leak is seen |
| | · Bushing at mounting part | · Wear on inner surface | · Replace |
| Gland | · Bushing | · Flaw on inner surface | · Replace if flaw is deeper than coating |