

SECTION 4 ELECTRICAL SYSTEM



Group 1 Component Location -----	4-1
Group 2 Electrical Circuit -----	4-3
Group 3 Electrical Component Specification -----	4-22
Group 4 Connectors -----	4-31

SECTION 4 ELECTRICAL SYSTEM

GROUP 1 COMPONENT LOCATION

1. LOCATION 1

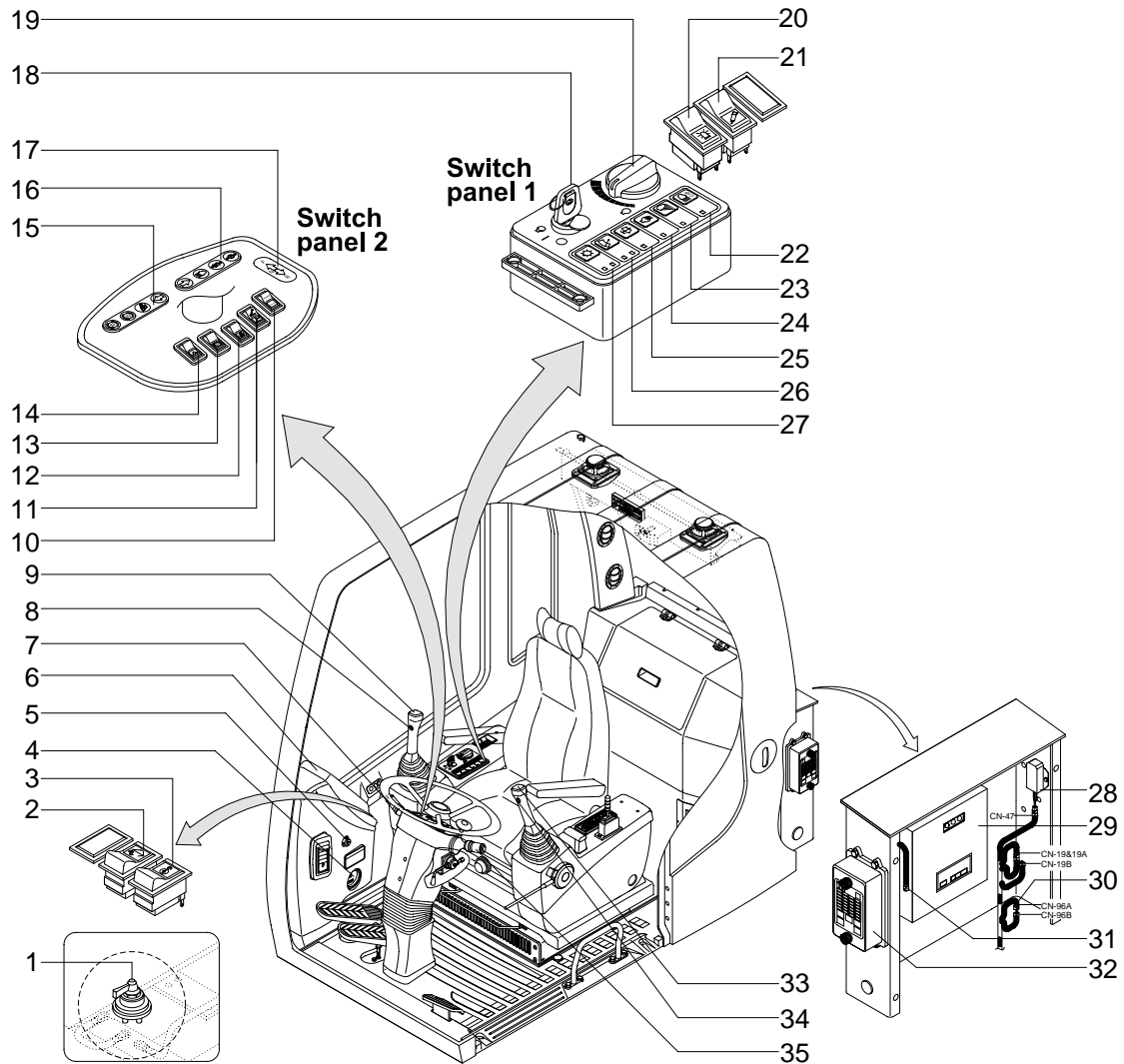

17W74EL01

- | | | | | | |
|----|---------------------------|----|----------------------------|----|--------------------------------------|
| 1 | Master switch | 13 | Parking brake switch | 25 | Washer switch |
| 2 | Quick clamp switch | 14 | Hazard switch | 26 | Wiper switch |
| 3 | Overload switch | 15 | Travel warning indicator 1 | 27 | Main light switch |
| 4 | Service meter | 16 | Travel warning indicator 2 | 28 | Prolix resistor |
| 5 | Cigar lighter | 17 | Forward/Reverse pilot lamp | 29 | CPU controller |
| 6 | Cluster | 18 | Start switch | 30 | Emergency engine starting controller |
| 7 | Multi function switch(RH) | 19 | Accel dial | 31 | RS232 serial connector |
| 8 | Breaker operation switch | 20 | Beacon switch | 32 | Fuse box |
| 9 | Horn switch | 21 | Breaker selection switch | 33 | One touch decel switch |
| 10 | Work/Travel switch | 22 | Cab light switch | 34 | Power max switch |
| 11 | Outrigger/Dozer switch | 23 | Work light switch | 35 | Multi function switch(LH) |
| 12 | Ram lock switch | 24 | Preheat switch | | |

2. LOCATION 2

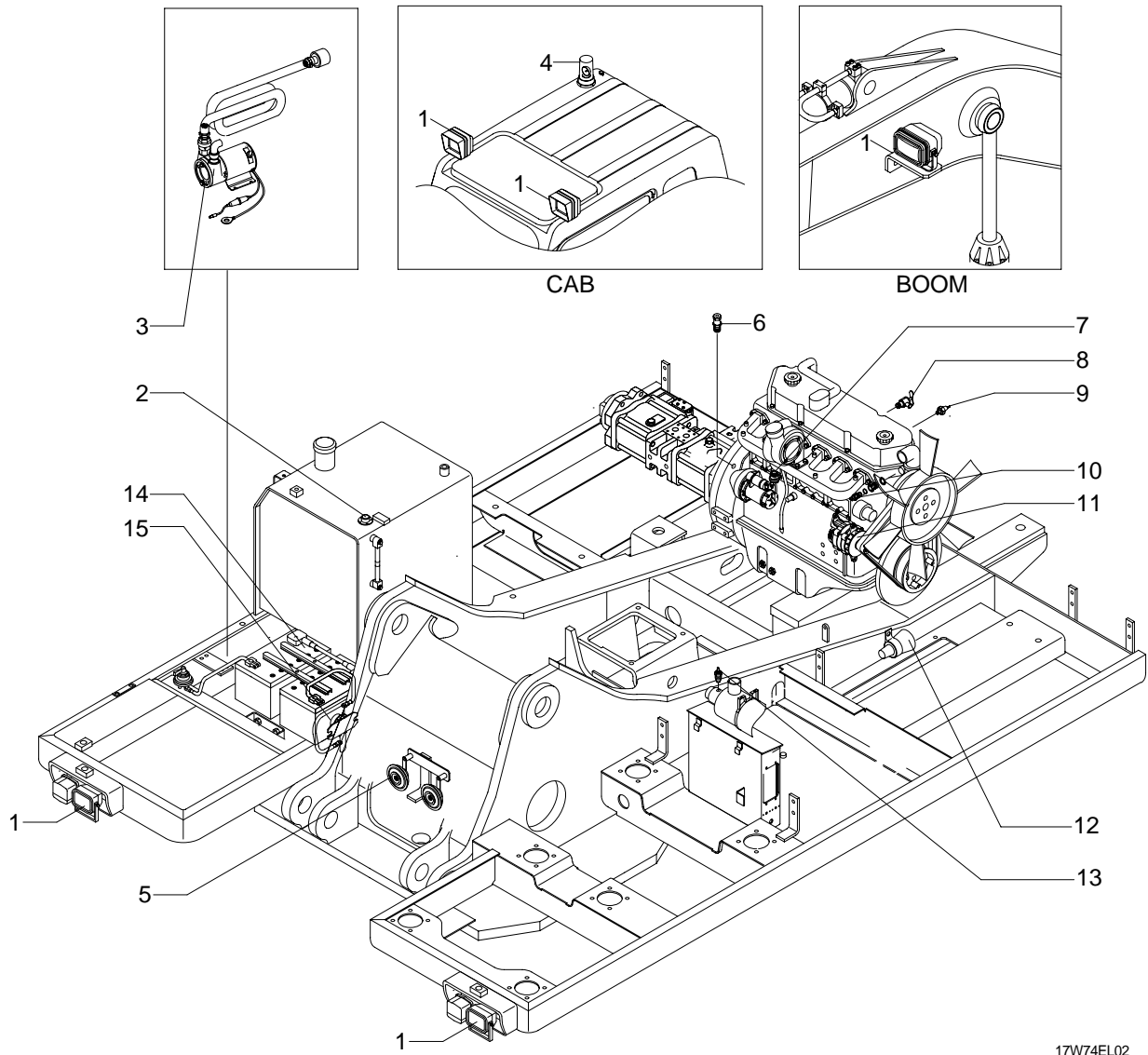

17W74EL02

- | | | | | | |
|---|------------------|----|----------------------------|----|---------------------|
| 1 | Lamp | 6 | Speed sensor | 11 | Alternator |
| 2 | Fuel sender | 7 | Start relay | 12 | Travel alarm buzzer |
| 3 | Fuel filler pump | 8 | Heater valve | 13 | Air cleaner switch |
| 4 | Beacon lamp | 9 | Engine oil pressure switch | 14 | Battery |
| 5 | Horn | 10 | Temp sender | 15 | Battery relay |