

GROUP 11 AXLE

1. OPERATION

- The power from the engine passes through main pump, travel motor and transmission and drive shafts, and is then sent to the front and rear axles.
- Inside the axles, the power passes from the bevel pinion to the bevel gear and is sent at right angles. At the same time, the speed is reduced and passes through the both differentials to the axle shafts. The power of the axle shafts is further reduced by planetary-gear-type final drives and is sent to the wheels.

1) FRONT AXLE

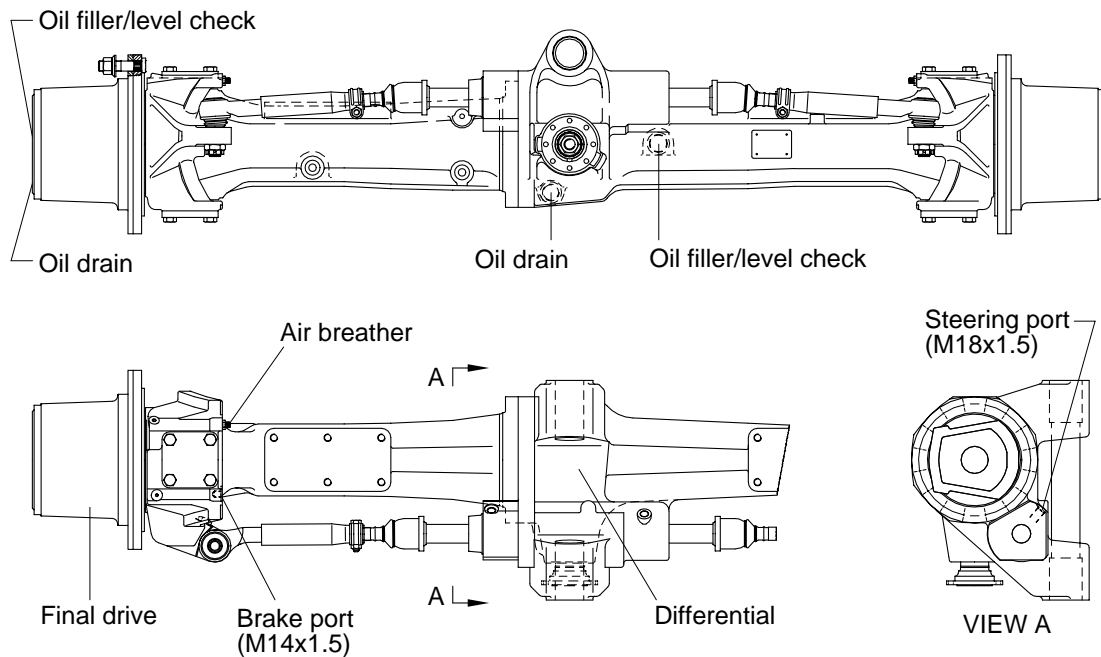

17032AX01(1)

2) REAR AXLE

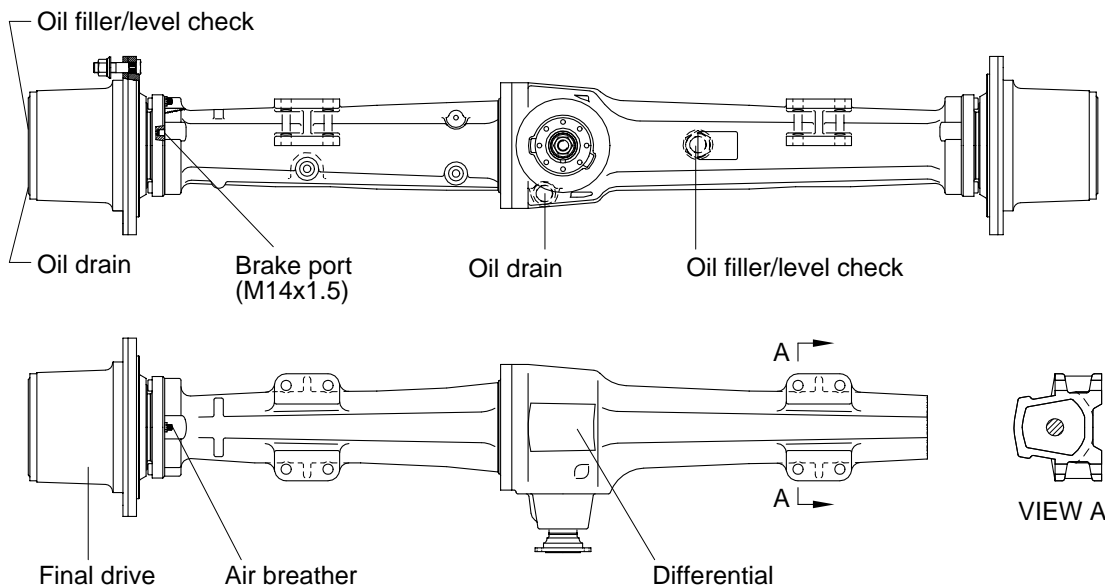

17032AX01(2)

2. SECTION OF DIFFERENTIAL

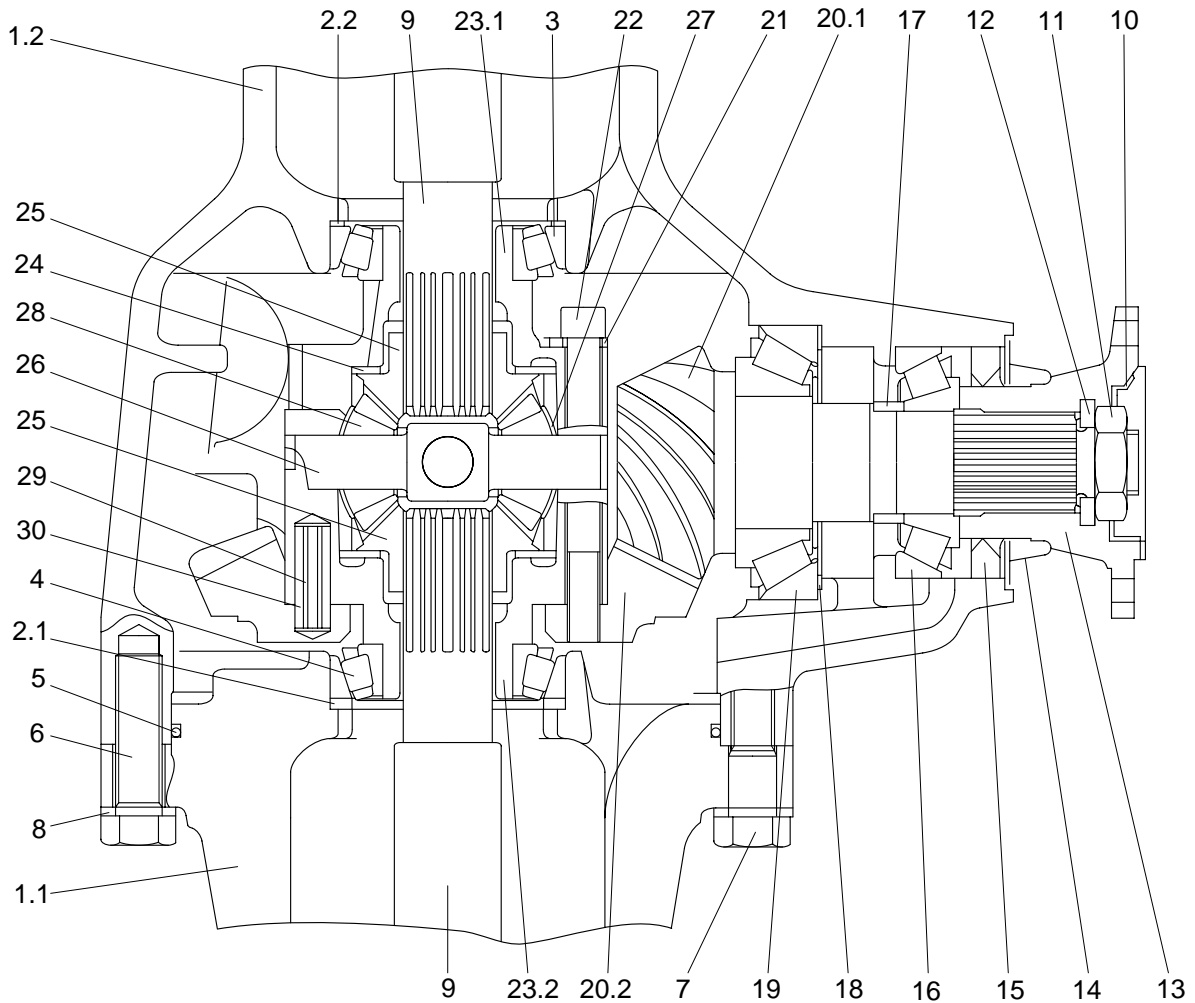

17032AX02

1.1	Axle 1	11	Hex head nut	22	Allen head screw
1.2	Axle 2	12	Washer	23.1	Differential housing 1
2.1	Shim	13	Drive flange	23.2	Differential housing 2
2.2	Shim	14	Cover	24	Thrust washer
3	Tapered roller bearing	15	Shaft seal ring	25	Tapered gear
4	Tapered roller bearing	16	Tapered roller bearing	26	Differential axle
5	O-ring	17	Bushing	27	Thrust washer
6	Hex head screw	18	Shim	28	Differential axle
7	Screw	19	Tapered roller bearing	29	Roll pin
8	Washer	20.1	Pinion	30	Roll pin
9	Tie rod	20.2	Ring		
10	Lock washer	21	Washer		

3. DIFFERENTIAL

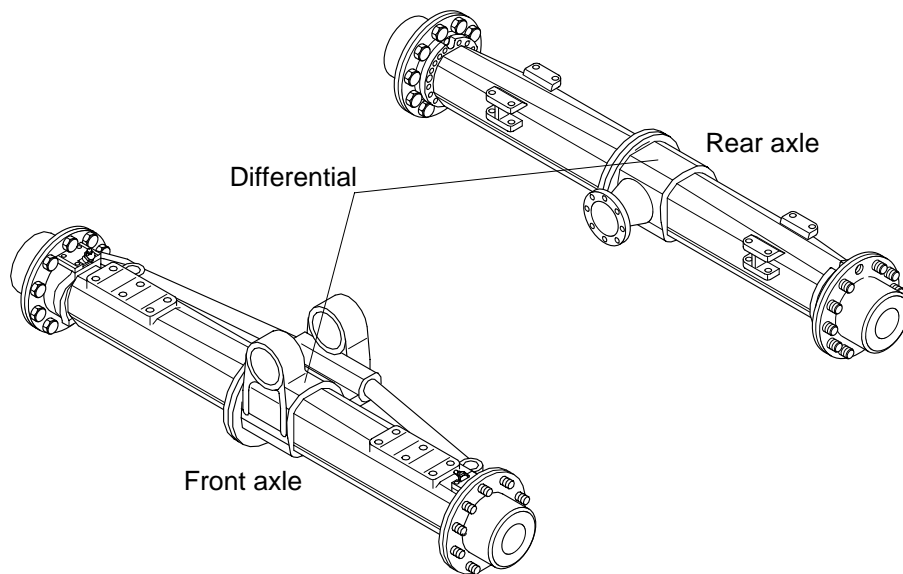

17032AX03

The differential is installed on the front and rear axle to transfer the driving torque from the axle to the wheels. The differential transfers half of the output torque of the transmission via the universal drive shaft to the planetary gear of the wheel hubs and transfers the rpm and torque from the gear via the pinion and the ring.

In addition, the differential also serves as an equalizer when going around curves. If the mechanical connection from the transmission to the universal drive shaft, differential, shaft, and planetary gears to the wheels would be rigid, every steering movement would strain the axle construction and would result in increased tire wear.

The equalizing function comes from the special construction of the differential. The power input from the input flange to the pinion shaft, ring and differential housing to the equalizing axle in the differential housing meshes the four equalizing tapered gears with the axle gears, which are located in the equalizing axles. This changes the relative direction of rotation between the shafts meshed with the side gears. This means that one shaft turns clockwise and the other counterclockwise, and one shaft turns faster than the other.

This balancing movement has the disadvantage that when traveling off road, traction is reduced on uneven ground, on loose ground or on snow or ice only wheel per axle is engaged. This disadvantage can be corrected in part by installing a self locking differential.

4. FINAL DRIVE

1) FRONT AXLE

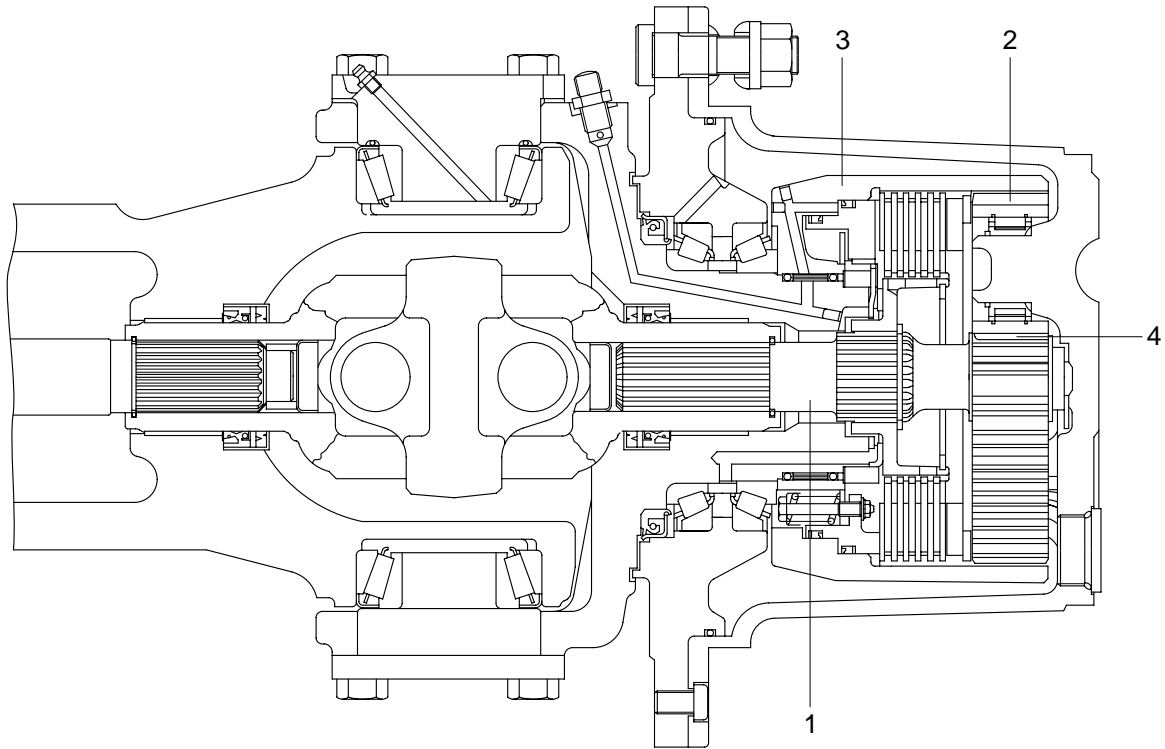

17032AX04

- | | | | | | |
|---|------------|---|----------------|---|-----------|
| 1 | Axle shaft | 2 | Planetary gear | 3 | Ring gear |
| 4 | Sun gear | | | | |

(1) To gain a large drive force, the final drive uses a planetary gear system to reduce the speed and send drive force to the tires.

(2) The power transmitted from the differential through axle shaft(1) to sun gear(4) is transmitted to planetary gear(2). The planetary gear rotates around the inside of a fixed ring gear(3) and in this way transmits rotation at a reduced speed to the planetary carrier.

This power is then sent to the wheels which are installed to the planetary carriers.

2) REAR AXLE

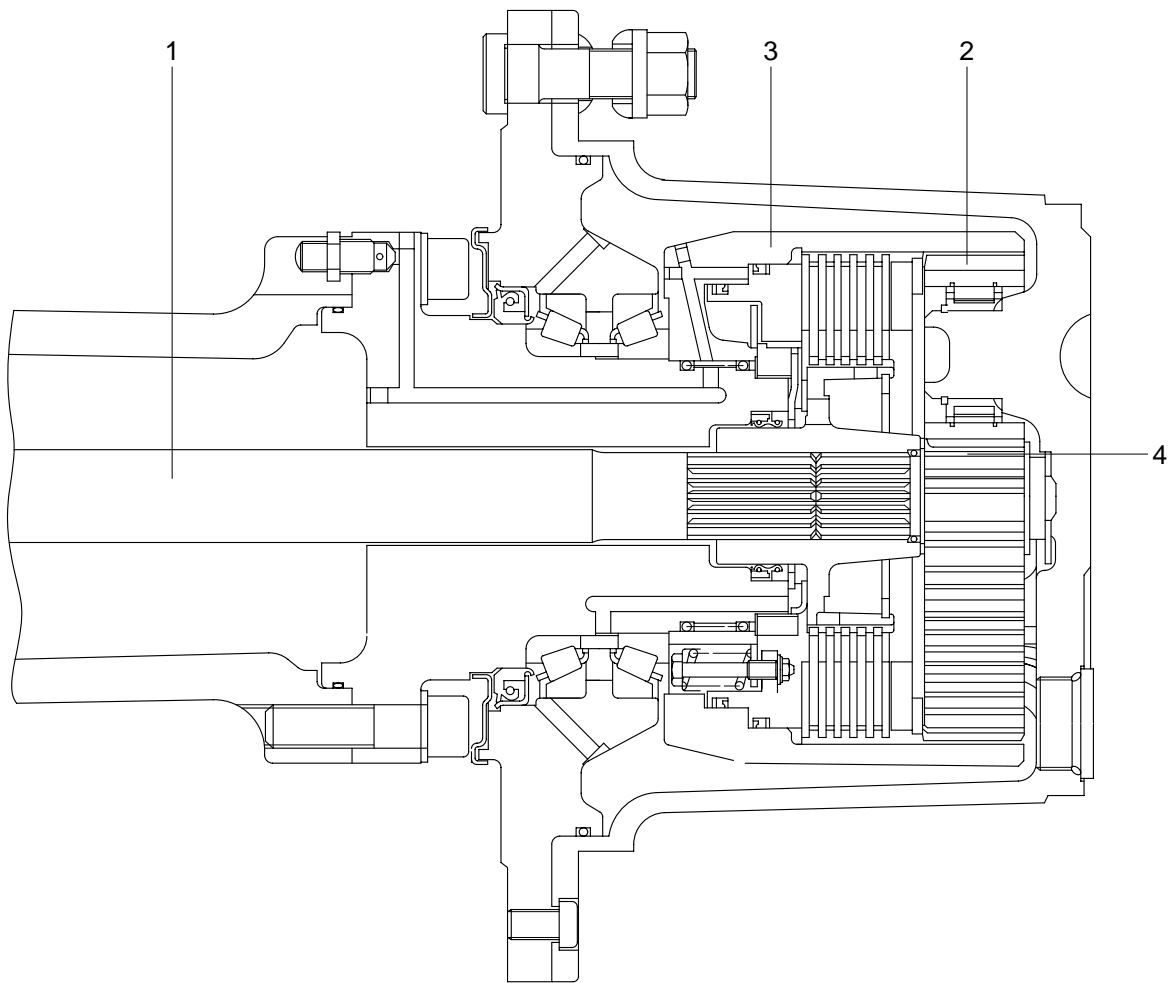

17032AX05

- | | | | | | |
|---|------------|---|----------------|---|-----------|
| 1 | Axle shaft | 2 | Planetary gear | 3 | Ring gear |
| 4 | Sun gear | | | | |

(1) To gain a large drive force, the final drive uses a planetary gear system to reduce the speed and send drive force to the tires.

(2) The power transmitted from the differential through axle shaft(1) to sun gear(4) is transmitted to planetary gear(2). The planetary gear rotates around the inside of a fixed ring gear(3) and in this way transmits rotation at a reduced speed to the planetary carrier.

This power is then sent to the wheels which are installed to the planetary carriers.

5. TIRE AND WHEEL

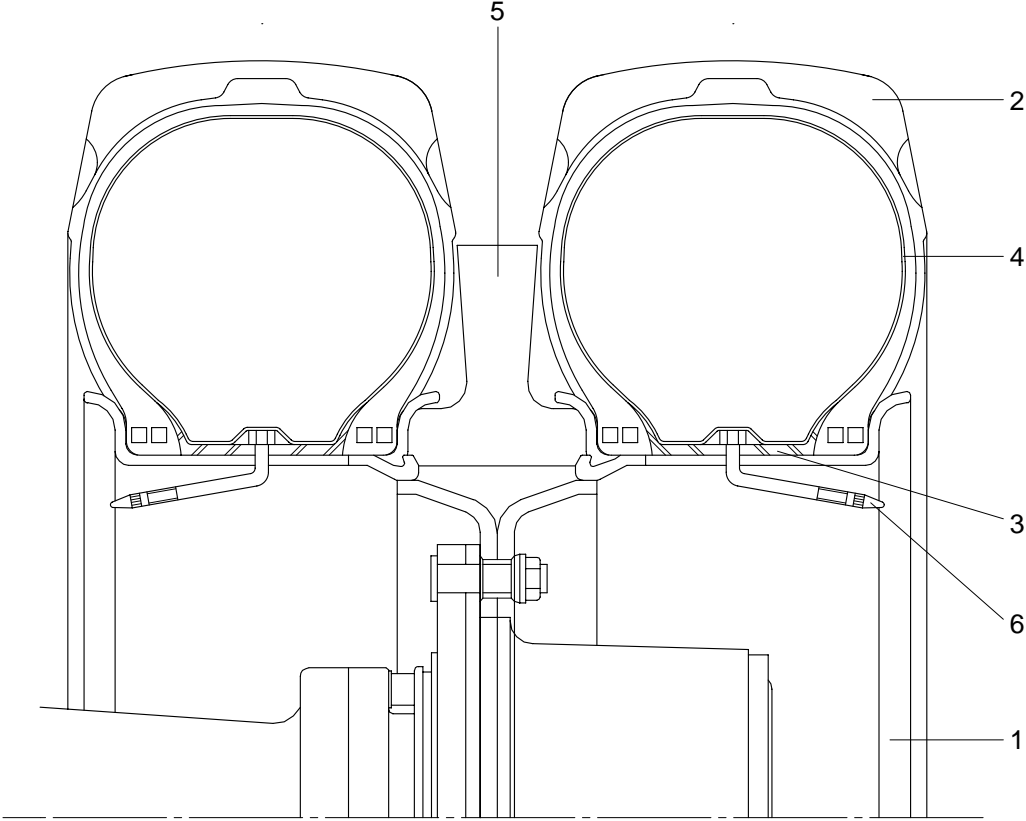

17032TJ01

- | | | | | | |
|---|-----------|---|------|---|---------------------|
| 1 | Wheel rim | 3 | Flap | 5 | Stone resistor ring |
| 2 | Tire | 4 | Tube | 6 | Valve assembly |

- 1) The tire acts to absorb the shock from the ground surface to the machine, and at the same time they must rotate in contact with the ground to gain the power which drives the machine.
- 2) Various types of tires are available to suit the purpose. Therefore it is very important to select the correct tires for the type of work and bucket capacity.