

GROUP 4 TRAVEL DEVICE

1. STRUCTURE

A Hydraulic motor includes followings.

- Part of rotary generating turning force
- Part of a valve of relief
- Part of Brake
- Part of a valve of counterbalance
- Part of flowing changeover
- Part of auto changeover

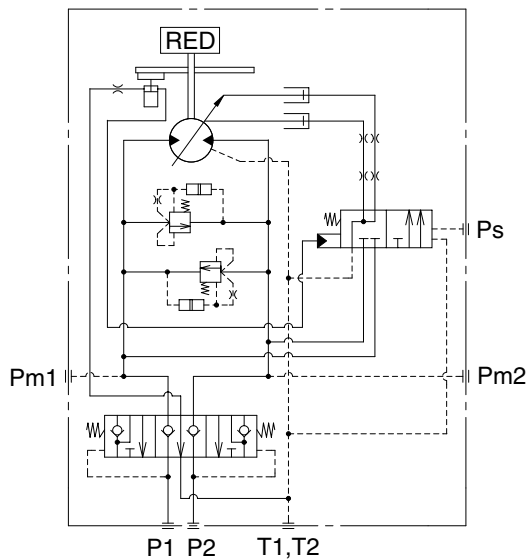
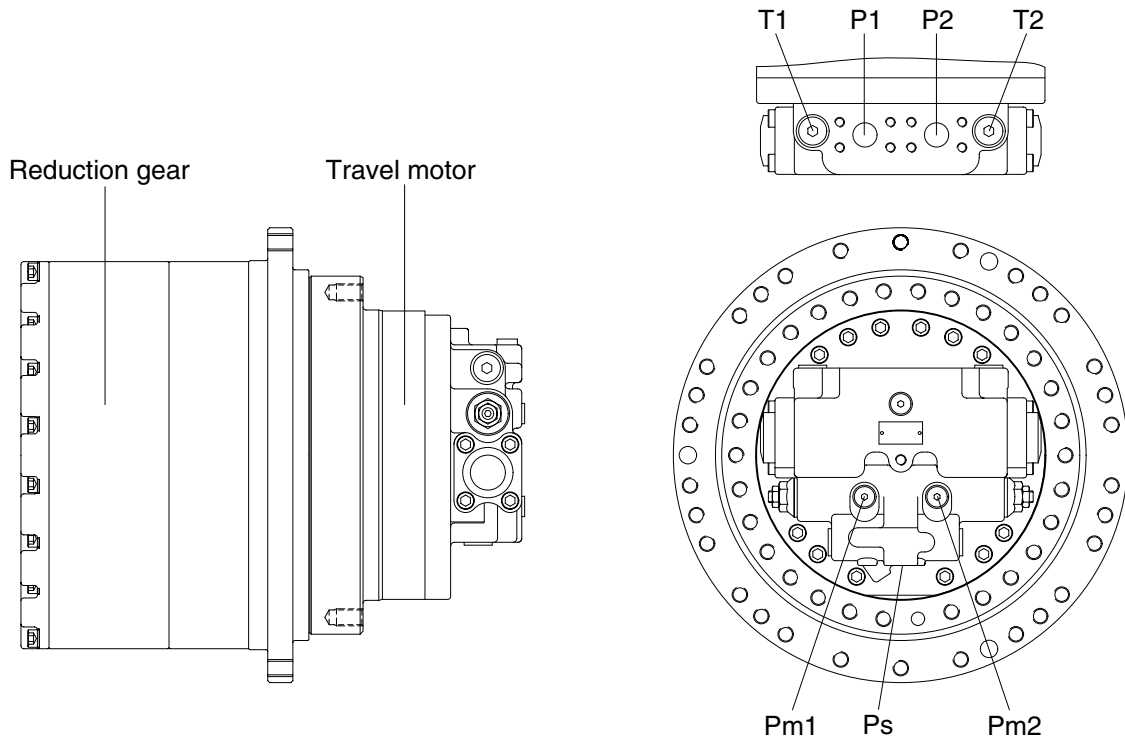

Hydraulic circuit

Port	Port name	Port size
P1, P2	Main port	SAE 4694psi 1"
Pm1, Pm2	Gauge port	PF 1/4
T1, T2	Drain port	PF 1/2
Ps	2 speed control port	PF 1/4

16092TM01

1) STRUCTURE

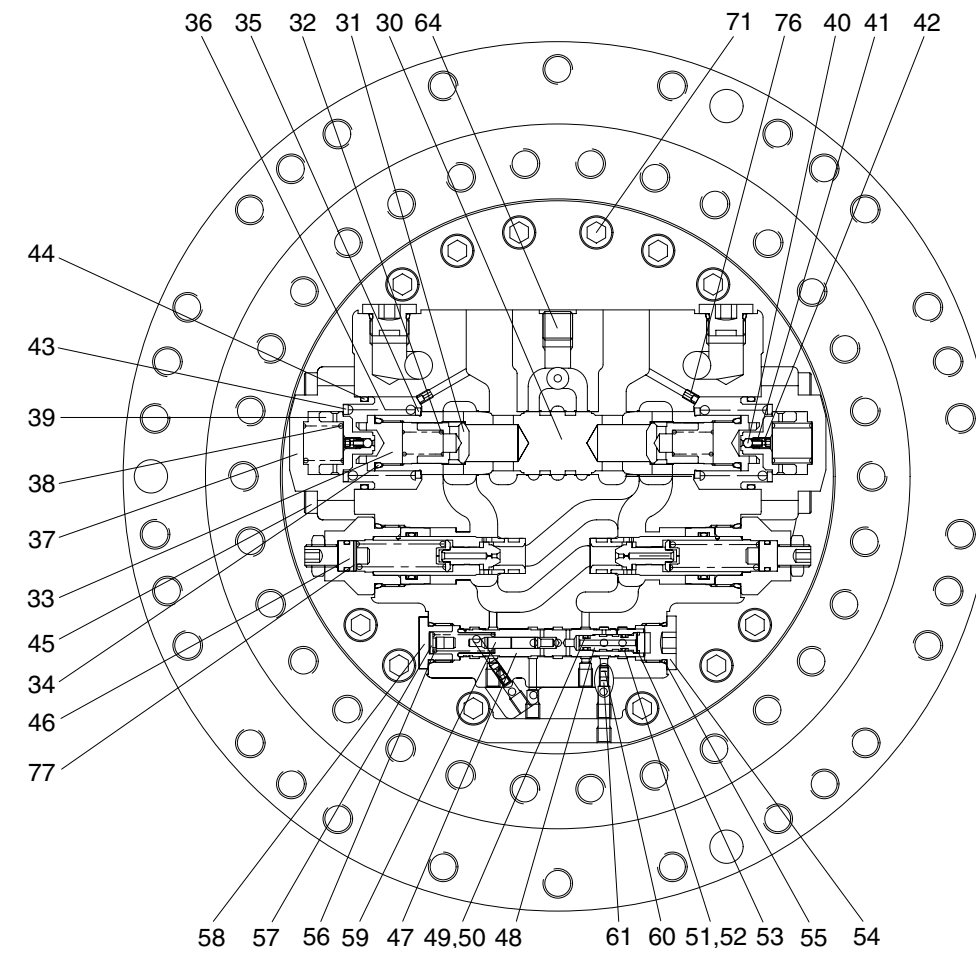
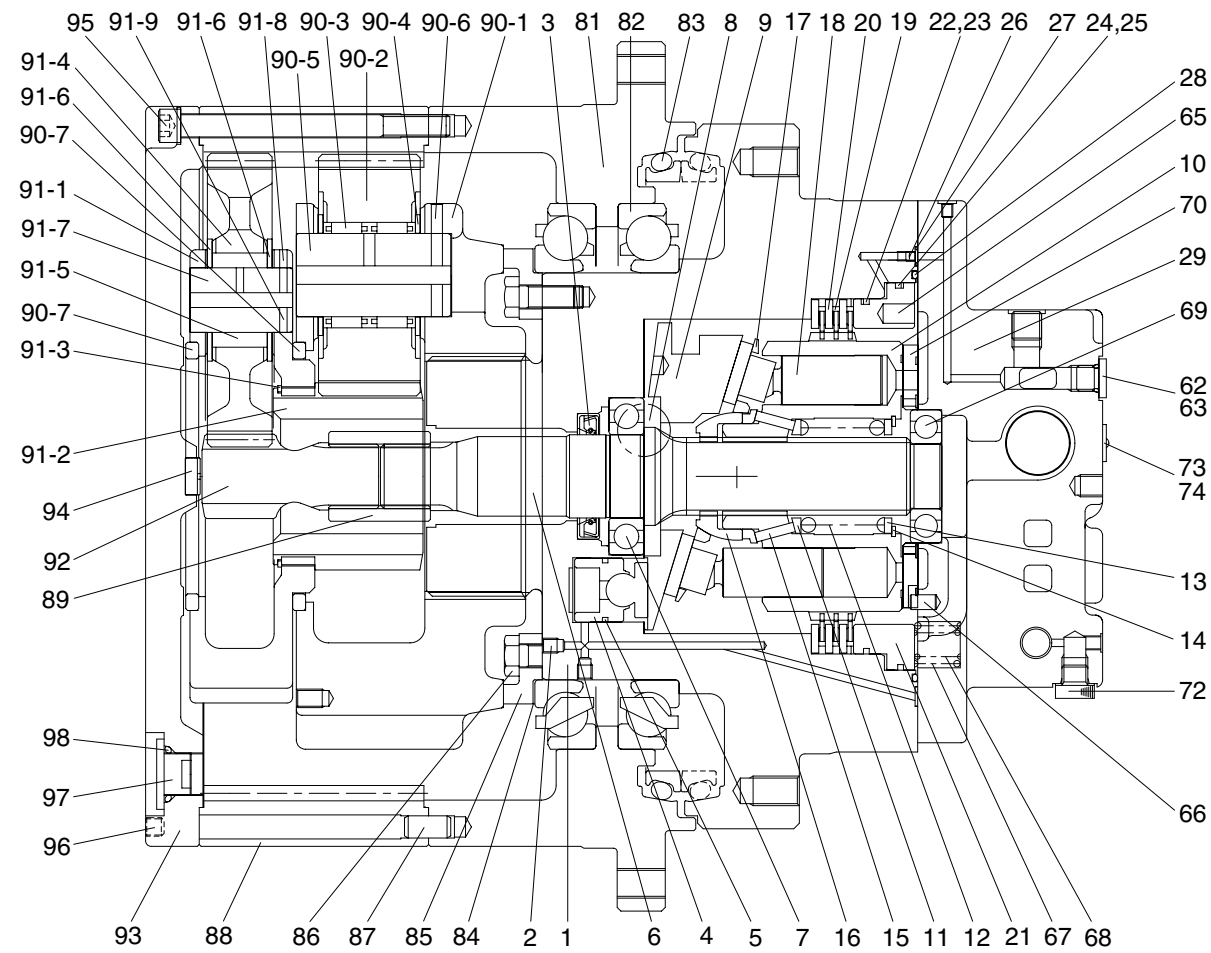

- | | | | | | |
|-------------------|-------------------|----------------------|----------------|--------------------------|--------------------------|
| 1 Shaft casing | 20 Separate plate | 39 Spool | 58 Plug | 77 Shim | 91-1 Carrier No.1 |
| 2 Plug | 21 Parking piston | 40 Steel ball | 59 Spool | 81 Housing | 91-2 Sun-gear No.2 |
| 3 Oil seal | 22 O-ring | 41 Spring | 60 Orifice | 82 Main bearing | 91-3 Retaining ring |
| 4 Swash piston | 23 Back up ring | 42 Plug | 61 Orifice | 83 Floating seal | 91-4 Planetary gear No.1 |
| 5 Piston ring | 24 O-ring | 43 Spring seat | 62 Plug | 84 Shim | 91-5 Needle bearing No.1 |
| 6 Shaft | 25 Back up ring | 44 O-ring | 63 O-ring | 85 Retainer | 91-6 Thrust washer |
| 7 Bearing | 26 Orifice | 45 Wrench bolt | 64 Plug | 86 Hex head bolt | 91-7 Pin No.1 |
| 8 Steel ball | 27 O-ring | 46 Relief valve assy | 65 Pin | 87 Parallel pin | 91-8 Spring pin |
| 9 Swash plate | 28 O-ring | 47 Spool | 66 Pin | 88 Ring gear | 91-9 Spring pin |
| 10 Cylinder block | 29 Rear cover | 48 Guide | 67 Spring | 89 Coupling | 92 Sun gear No.1 |
| 11 Spring seat | 30 Spool | 49 O-ring | 68 Spring | 90 Carrier assy No.2 | 93 Cover |
| 12 Spring | 31 Check | 50 Back up ring | 69 Bearing | 90-1 Carrier No.2 | 94 Pad |
| 13 End plate | 32 Spring | 51 O-ring | 70 Valve plate | 90-2 Planetary gear No.2 | 95 Hex socket head bolt |
| 14 Snap ring | 33 Plug | 52 Back up ring | 71 Wrench bolt | 90-3 Needle bearing No.2 | 96 Hex socket Screw |
| 15 Pin | 34 O-ring | 53 Snap ring | 72 Plug | 90-4 Thrust washer | 97 Hydraulic plug |
| 16 Ball guide | 35 Spring seat | 54 plug | 73 Name plate | 90-5 Pin No.2 | 98 O-ring |
| 17 Set plate | 36 Spring | 55 O-ring | 74 Rivet | 90-6 Spring pin | 99 Name plate |
| 18 Piston assy | 37 Cover | 56 Spring | 75 Seal kit | 90-7 Thrust ring | |
| 19 Friction plate | 38 Spring | 57 Spring seat | 76 Orifice | 91 Carrier assy No.1 | |

16092TM02

2. PRINCIPLE OF DRIVING

2.1 Generating the turning force

The high hydraulic supplied from a hydraulic pump flows into a cylinder (10) through valve casing of motor (29), and valve plate (77).

The high hydraulic is built as flowing on one side of Y-Y line connected by the upper and lower sides of piston(18).

The high hydraulic can generate the force, $F1 = P \times A$ (P : supplied pressure, A : water pressure area), like following pictures, working on a piston.

This force, $F1$, is divided as $N1$ thrust partial pressure and $W1$ radial partial pressure, in case of the plate (09) of a tilt angle, α .

$W1$ generates torque, $T = W1 \times R1$, for Y-Y line connected by the upper and lower sides of piston as following pictures.

The sum of torque ($\sum W1 \times R1$), generated from each piston (4~5pieces) on the side of a high hydraulic, generates the turning force.

This torque transfers the turning force to a cylinder (10) through a piston; because a cylinder is combined with a turning axis and spline, a turning axis rotates and a turning force is sent.

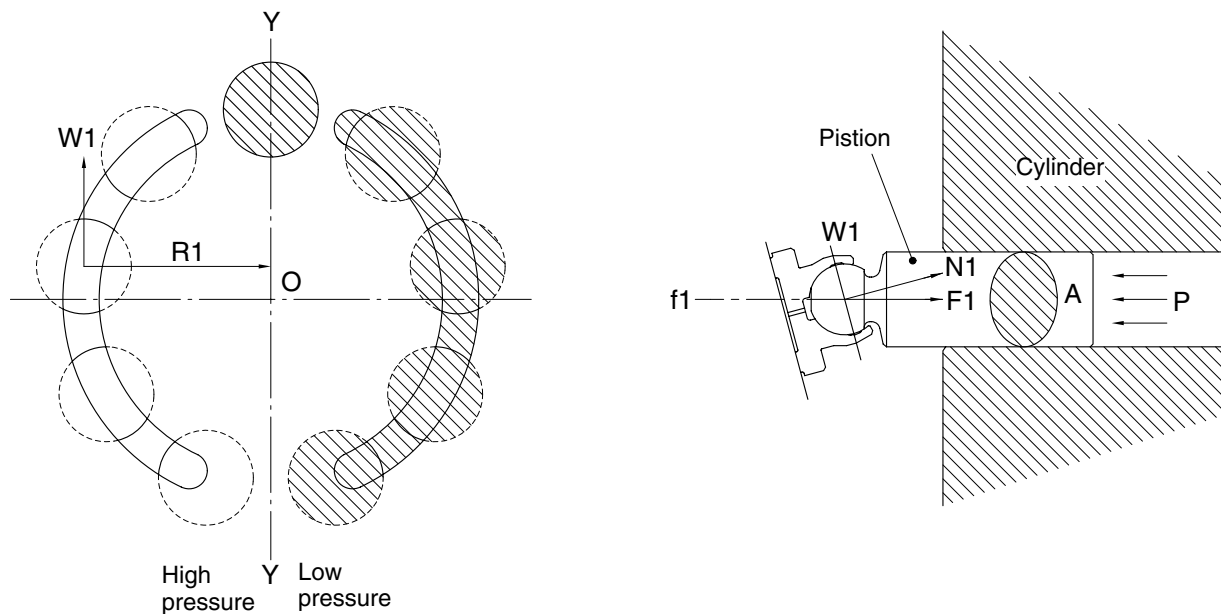

21078TM05

2.2 Working of relief valve

Relief valve carries on two functions of followings.

- 1) It standardizes a pressure in case of driving a hydraulic motor ; bypasses and extra oil in a motor inlet related to acceleration of an inertia to an outlet.
- 2) In case of an inertia stopped, it forces an equipment stopped, according to generating the pressure of a brake on the projected side.

Room A is always connected with port A of a motor. If the pressure of port is increased, press poppet A. And if it is higher than the setting pressure of a spring, the oil of an hydraulic flows from room A to port B, because poppet A is detached from the contact surface of seat A.

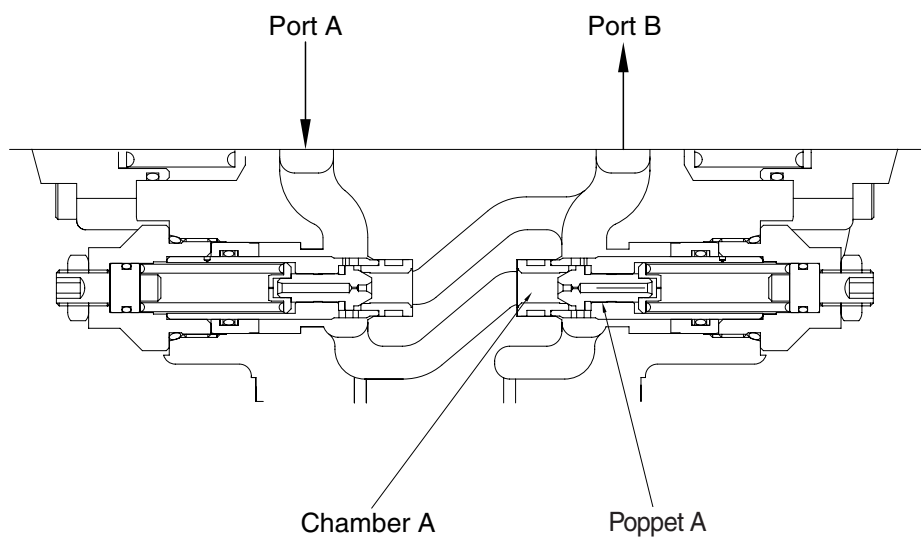

21078TM06A

2.3 Working of negative brake

When the operating pressure is supplied to the brake piston (21) through the spool (simultaneous peripheral operation online) built in the shaft casing (1), the negative brake is released.

When the pressure does not work, the brake always runs.

The force of a brake is generated by the frictional force among a separate plate (20) fixed by shaft casing, parking piston (21) and a frictional plate (19) connected through spline outside a cylinder block (10).

When a pressure does not work on the part of piston, brake spring presses brake piston; oil in a brake room flows into the drain of a motor through an orifice; in that time, brake piston compresses a frictional plate and a detached plate in the middle of shaft casing (1) and brake piston (21) according to the force that presses 10 pieces of brake springs (67, 68); finally, it makes a frictional force.

This frictional force helps the brake fixing a turning shaft (6) connected by a cylinder and spline operated.

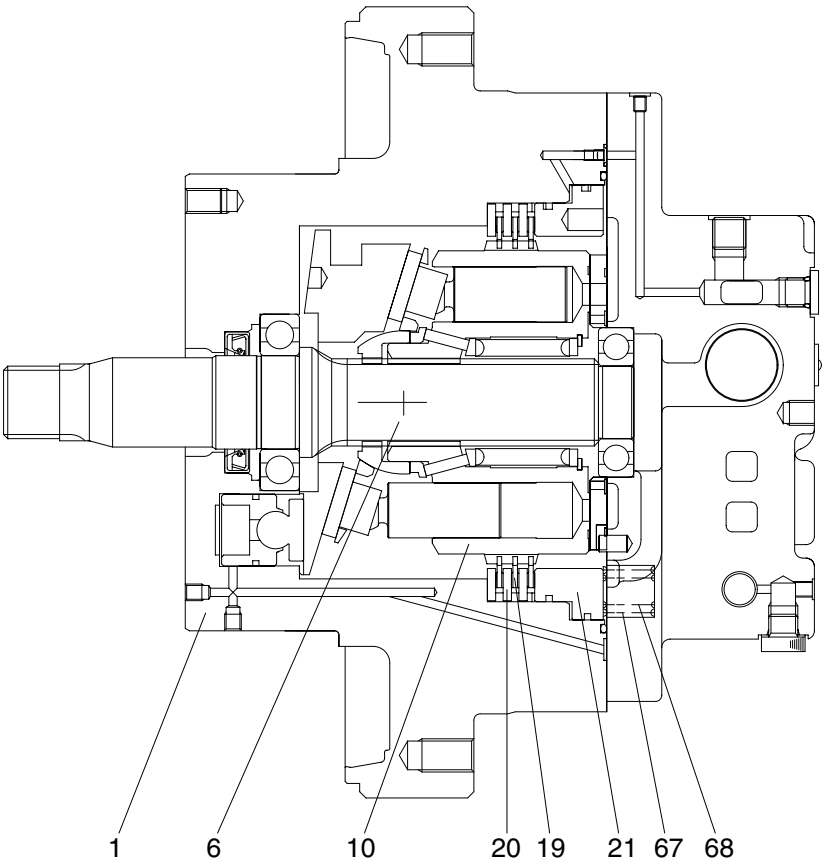

21092TM07

2.4 Counterbalance valve

Av port is connected to a hydraulic pump; Bv port is connected to a tank.

An oil supplied from a hydraulic pump presses check valve and flows into L port. It makes a hydraulic motor circulated. The oil pressure out of a pump is increased and transferred to spring room M through the path G because negative brake is working on. When the pressure of room M exceeds the force of spring that keeps spool at its neutral position, the spool begins to move the right side.

An oil in room N is sent to room M by orifice I and discharged from G line to a tank.

Then the spool moves to the right and the oil flows from K to Bv.

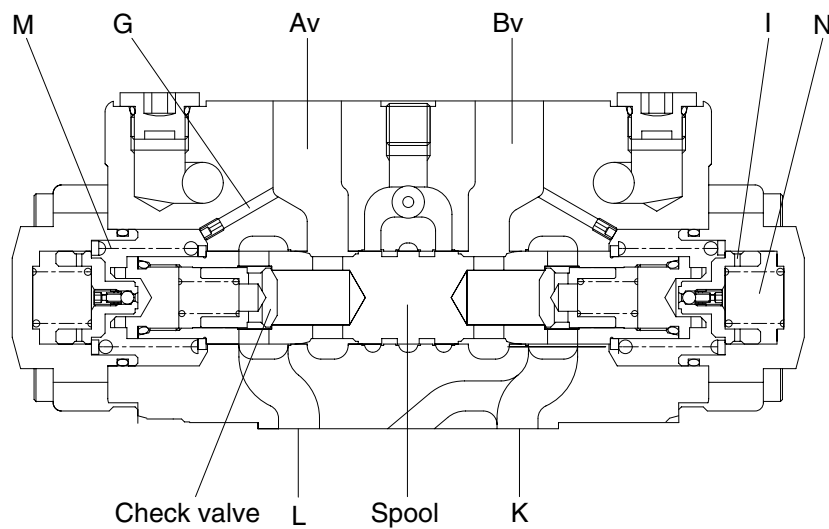

21078TM08

2.5 Working description of automatic switch (at normal speed)

Due to no pressure on pilot now, spool (47) is not working.

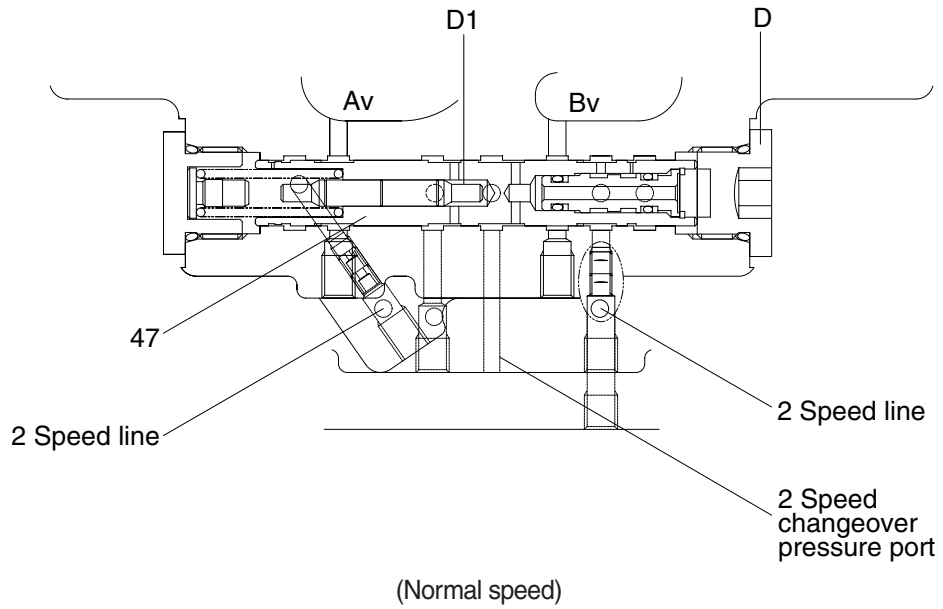

21078TM09

2.6 Working description of automatic switch (at high speed)

At normal speed, once the hydraulic oil which is through the inner path of spool (47) flows into high speed switching pressure port (the pressure of external pilot : $P_i = 35 \text{ kgf/cm}^2$) spool(47) moves from right to left.

At high speed, turning pressure of motor (D1) is over 250 kgf/cm^2 , when the power forcing to spool (59) (Pressure, P1) is stronger than spool (47) and spool (59) is pushed out, after then spool (47) moves from left to right. So it is switched.

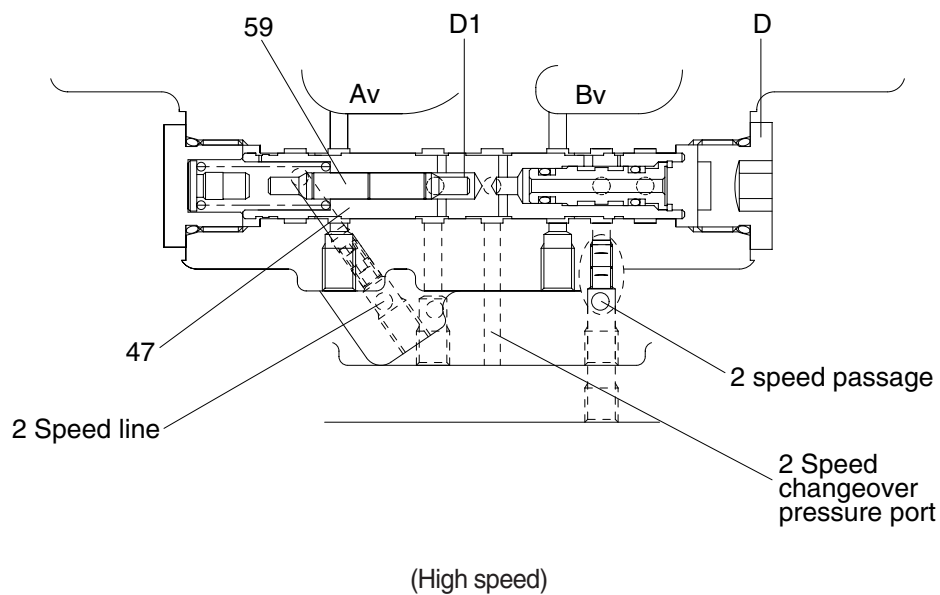

21078TM10