

GROUP 2 SPECIFICATIONS (R160LC-9)

1. MAJOR COMPONENT

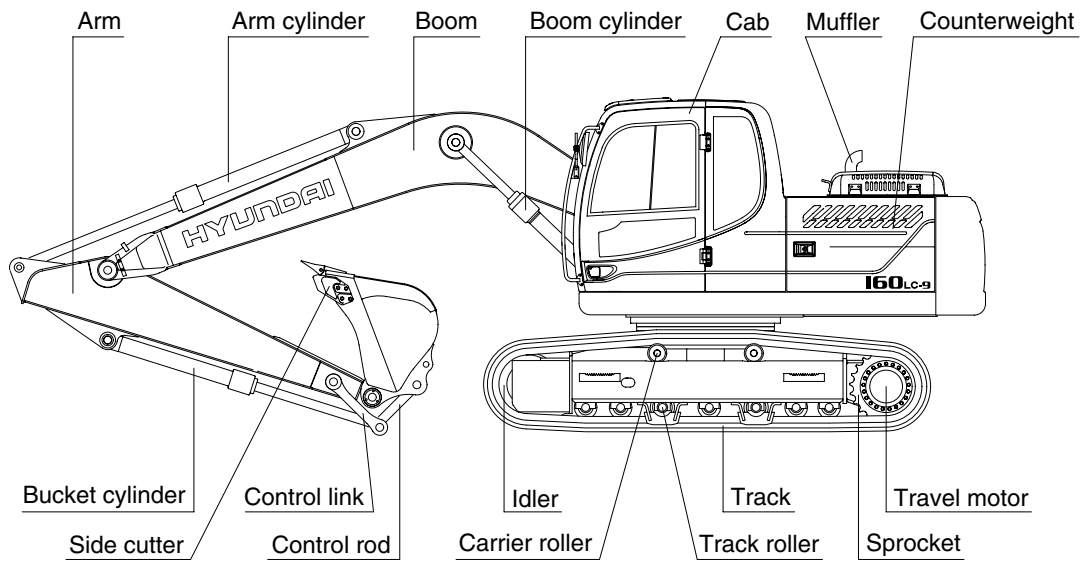
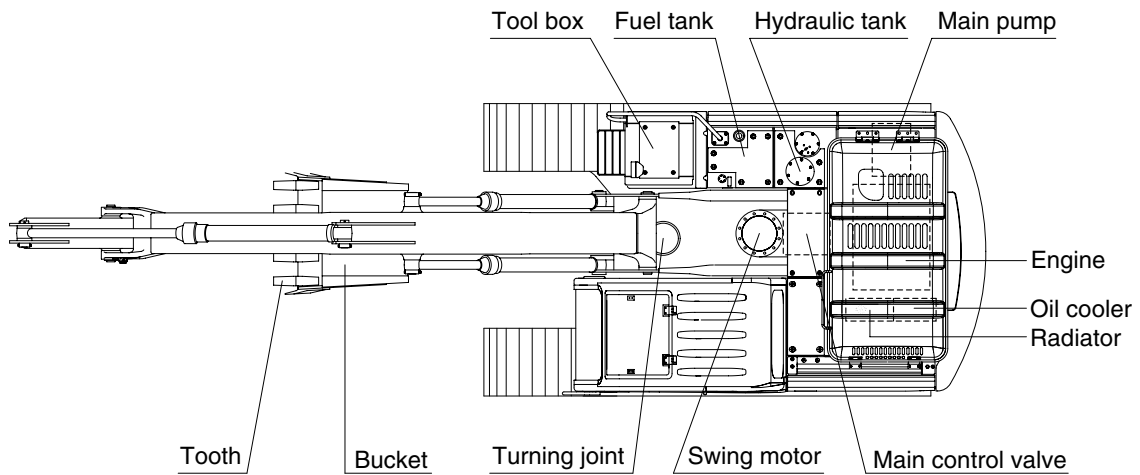

16092SP01

2. SPECIFICATIONS

1) R160LC-9

· 5.1 m (16' 9") BOOM and 2.6 m (8' 6") ARM

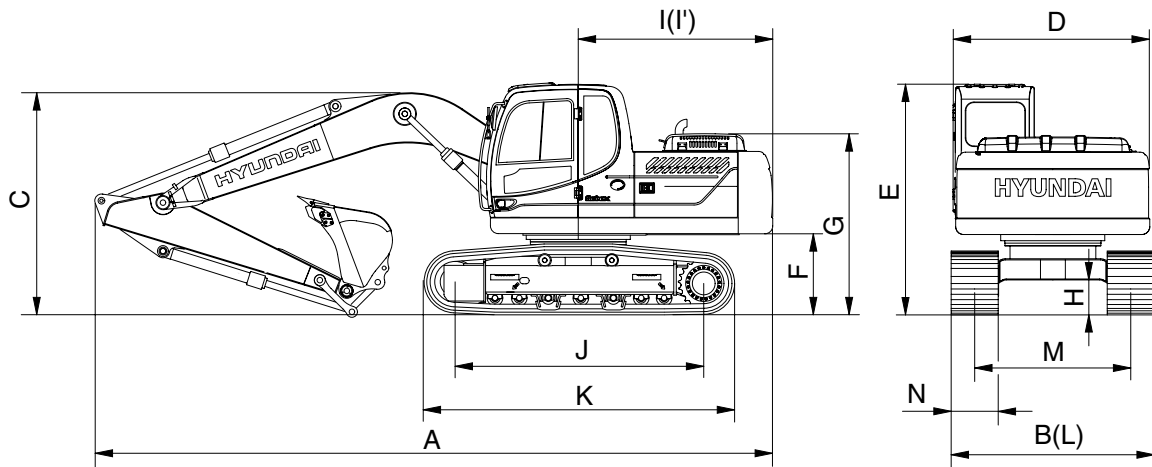

16092SP02

Description		Unit	Specification
Operating weight		kg (lb)	17800 (39240)
Bucket capacity (SAE heaped), standard		m ³ (yd ³)	0.70 (0.92)
Overall length	A	mm (ft-in)	8650 (28' 5")
Overall width, with 600 mm shoe	B		2590 (8' 6")
Overall height	C		2990 (9' 10")
Superstructure width	D		2475 (8' 1")
Overall height of cab	E		2980 (9' 9")
Ground clearance of counterweight	F		1055 (3' 6")
Engine cover height	G		2315 (7' 7")
Minimum ground clearance	H		460 (1' 6")
Rear-end distance	I		2480 (8' 2")
Rear-end swing radius	I'		2530 (8' 4")
Distance between tumblers	J		3170 (10' 5")
Undercarriage length	K		3960 (13' 0")
Undercarriage width	L		2590 (8' 6")
Track gauge	M		1990 (6' 6")
Track shoe width, standard	N		600 (24")
Travel speed (low/high)		km/hr (mph)	3.2/5.5 (2.0/3.4)
Swing speed		rpm	11.3
Gradeability		Degree (%)	30 (58)
Ground pressure (600 mm shoe)		kgf/cm ² (psi)	0.43 (6.11)
Max traction force		kg (lb)	17000 (37478)

2) R160LC-9

- 5.1 m (16' 9") HYDRAULIC ADJUSTABLE BOOM AND 2.6 m (8' 6") ARM

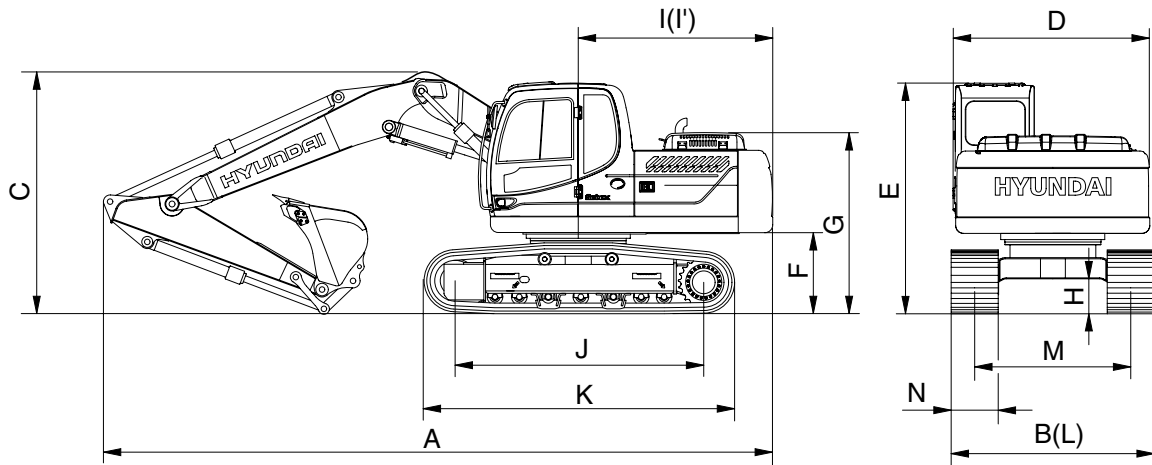

16092SP03

Description		Unit	Specification
Operating weight		kg (lb)	18290 (40320)
Bucket capacity (SAE heaped), standard		m ³ (yd ³)	0.70 (0.92)
Overall length	A	mm (ft-in)	8610 (28' 3")
Overall width, with 600 mm shoe	B		2590 (8' 6")
Overall height	C		3060 (10' 0")
Superstructure width	D		2475 (8' 1")
Overall height of cab	E		2980 (9' 9")
Ground clearance of counterweight	F		1055 (3' 6")
Engine cover height	G		2315 (7' 7")
Minimum ground clearance	H		460 (1' 6")
Rear-end distance	I		2480 (8' 2")
Rear-end swing radius	I'		2480 (8' 2")
Distance between tumbler	J		2530 (8' 4")
Undercarriage length	K		3960 (13' 0")
Undercarriage width	L		2590 (8' 6")
Track gauge	M		1990 (6' 6")
Track shoe width, standard	N		600 (24")
Travel speed (low/high)		km/hr (mph)	3.2/5.5 (2.0/3.4)
Swing speed		rpm	11.3
Gradeability		Degree (%)	30 (58)
Ground pressure (600 mm shoe)		kgf/cm ² (psi)	0.44 (6.33)
Max traction force		kg (lb)	11000 (37478)

3) R160LCD-9

· 5.1 m (16' 9") BOOM and 2.6 m (8' 6") ARM

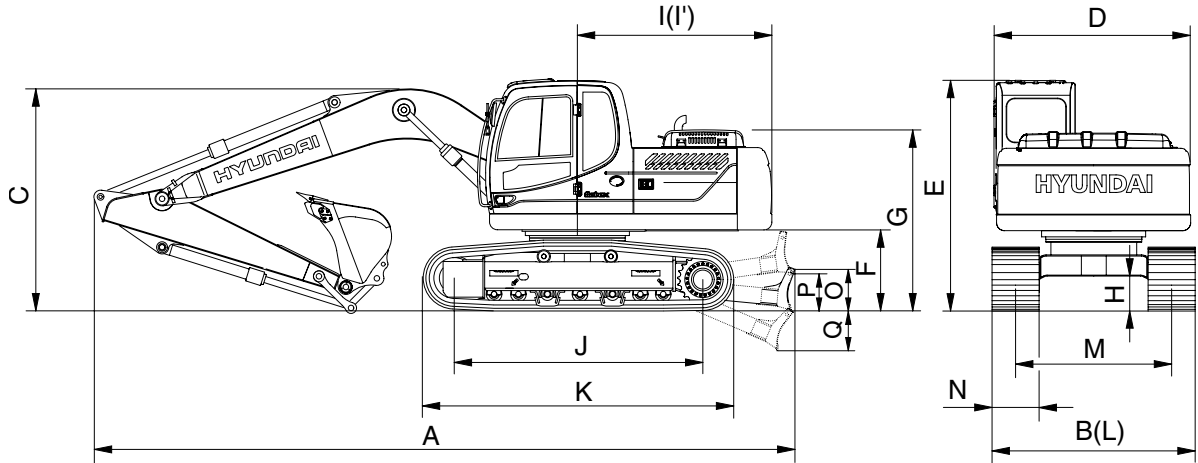

16092SP04

Description		Unit	Specification
Operating weight		kg (lb)	18800 (41450)
Bucket capacity (SAE heaped), standard		m ³ (yd ³)	0.70 (0.92)
Overall length	A	mm (ft-in)	9100 (29' 10")
Overall width, with 600 mm shoe	B		2590 (8' 6")
Overall height	C		2990 (9'10")
Superstructure width	D		2475 (8' 1")
Overall height of cab	E		2980 (9' 9")
Ground clearance of counterweight	F		1055 (3' 6")
Engine cover height	G		2315 (7' 7")
Minimum ground clearance	H		460 (1' 6")
Rear-end distance	I		2480 (8' 2")
Rear-end swing radius	I'		2530 (8' 4")
Distance between tumblers	J		3170 (10' 5")
Undercarriage length	K		3960 (13' 0")
Undercarriage width	L		2590 (8' 6")
Track gauge	M		1990 (6' 6")
Track shoe width, standard	N		600 (24")
Height of blade	O		640 (2' 1")
Ground clearance of blade up	P		615 (2' 0")
Depth of blade down	Q		675 (2' 3")
Travel speed (low/high)			km/hr (mph)
Swing speed		rpm	11.3
Gradeability		Degree (%)	30 (58)
Ground pressure (600 mm shoe)		kgf/cm ² (psi)	0.46 (6.54)
Max traction force		kg (lb)	17000 (37478)

3) GEAR PUMP

Item	Specification
Type	Fixed displacement gear pump single stage
Capacity	15cc/rev
Maximum pressure	40 kgf/cm ² (570 psi)
Rated oil flow	30 l /min (7.9 U.S. gpm / 6.6 U.K. gpm)

4) MAIN CONTROL VALVE

Item	Specification
Type	11 spools two-block
Operating method	Hydraulic pilot system
Main relief valve pressure	350 kgf/cm ² (4980 psi) [380 kgf/cm ² (5400 psi)]
Overload relief valve pressure	400 kgf/cm ² (5690 psi)

[] : Power boost

5) SWING MOTOR

Item	Specification
Type	Two fixed displacement axial piston motor
Capacity	117.8 cc/rev
Relief pressure	285 kgf/cm ² (4053 psi)
Braking system	Automatic, spring applied hydraulic released
Braking torque	59 kgf · m (427 lbf · ft)
Brake release pressure	33~50 kgf/cm ² (469~711 psi)
Reduction gear type	2 - stage planetary

6) TRAVEL MOTOR

Item	Specification
Type	Variable displacement axial piston motor
Relief pressure	350 kgf/cm ² (4980 psi)
Reduction gear type	Planetary & differential type
Braking system	Automatic, spring applied hydraulic released
Brake release pressure	11 kgf/cm ² (156 psi)
Braking torque	49.3 kgf · m (357 lbf · ft)

3. WORKING RANGE

1) 5.1 m (16' 9") MONO BOOM

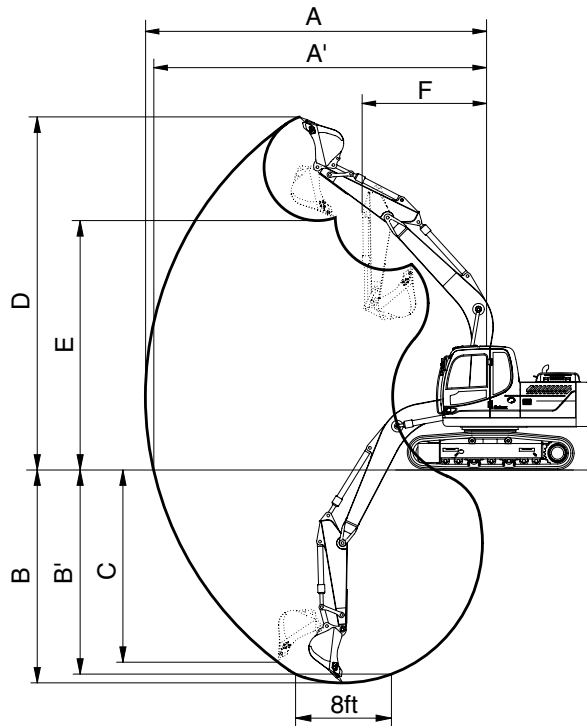

16092SP05

Description		2.2 m (7' 3") Arm	2.6 m (8' 6") Arm	3.1 m (10' 2") Arm
Max digging reach	A	8690 mm (28' 6")	9020 mm (29' 7")	9450 mm (31' 0")
Max digging reach on ground	A'	8530 mm (27' 12")	8860 mm (29' 1")	9300 mm (30' 6")
Max digging depth	B	5660 mm (18' 7")	6060 mm (19' 11")	6560 mm (21' 6")
Max digging depth (8ft level)	B'	5430 mm (17' 10")	5850 mm (19' 2")	6370 mm (20' 11")
Max vertical wall digging depth	C	5120 mm (16' 10")	5380 mm (17' 8")	5710 mm (18' 9")
Max digging height	D	8750 mm (28' 8")	8840 mm (29' 0")	8980 mm (29' 6")
Max dumping height	E	6110 mm (20' 1")	6220 mm (20' 5")	6390 mm (21' 0")
Min swing radius	F	3180 mm (10' 5")	3170 mm (10' 5")	3170 mm (10' 5")
Bucket digging force	SAE	107.9 [117.2] kN	107.9 [117.2] kN	107.9 [117.2] kN
		11000 [11940] kgf	11000 [11940] kgf	11000 [11940] kgf
		24250 [26330] lbf	24250 [26330] lbf	24250 [26330] lbf
	ISO	123.6 [134.2] kN	123.6 [134.2] kN	123.6 [134.2] kN
		12600 [13680] kgf	12600 [13680] kgf	12600 [13680] kgf
		27780 [30160] lbf	27780 [30160] lbf	27780 [30160] lbf
Arm crowd force	SAE	87.2 [94.7] kN	77.3 [83.9] kN	69.0 [74.9] kN
		8890 [9650] kgf	7880 [8560] kgf	7030 [7630] kgf
		19600 [21280] lbf	17370 [18860] lbf	15500 [16830] lbf
	ISO	91.0 [98.8] kN	80.3 [87.2] kN	71.4 [77.5] kN
		9280 [10080] kgf	8190 [8890] kgf	7280 [7900] kgf
		20460 [22210] lbf	18060 [19600] lbf	16050 [17430] lbf

[] : Power boost

2) 5.1 m (16' 9") HYDRAULIC ADJUSTABLE BOOM

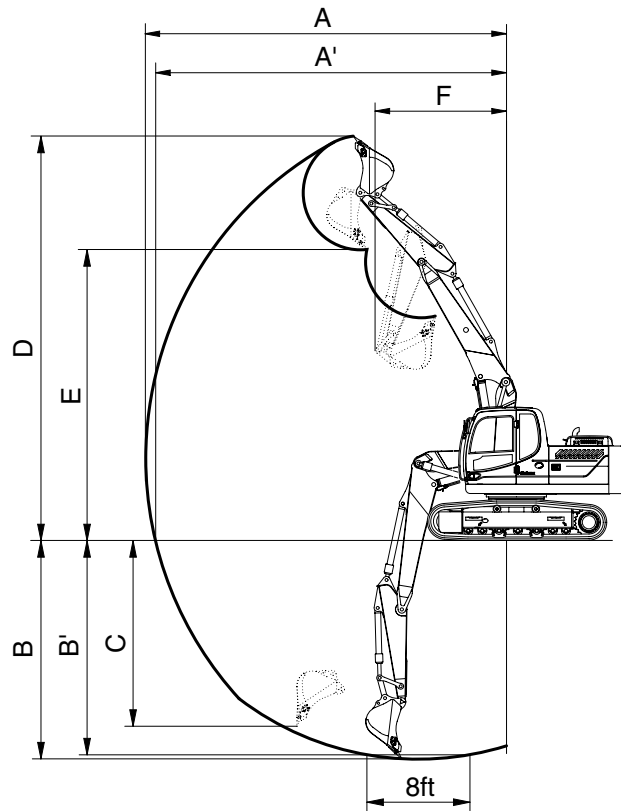

16092SP06

Description		2.2 m (7' 3") Arm	2.6 m (8' 6") Arm
Max digging reach	A	8760 mm (28' 9")	9110 mm (29' 11")
Max digging reach on ground	A'	8590 mm (28' 2")	8950 mm (29' 4")
Max digging depth	B	5430 mm (17' 10")	5830 mm (19' 2")
Max digging depth (8ft level)	B'	5330 mm (17' 6")	5730 mm (18' 10")
Max vertical wall digging depth	C	4630 mm (15' 2")	4980 mm (16' 4")
Max digging height	D	9420 mm (30' 11")	9610 mm (31' 6")
Max dumping height	E	6710 mm (22' 0")	6910 mm (22' 8")
Min swing radius	F	3100 mm (10' 2")	2970 mm (9' 9")
Bucket digging force	SAE	107.9 [117.2] kN	107.9 [117.2] kN
		11000 [11940] kgf	11000 [11940] kgf
		24250 [26330] lbf	24250 [26330] lbf
	ISO	123.6 [134.2] kN	123.6 [134.2] kN
		12600 [13680] kgf	12600 [13680] kgf
		27780 [30160] lbf	27780 [30160] lbf
Arm crowd force	SAE	87.2 [94.7] kN	77.3 [83.9] kN
		8890 [9650] kgf	7880 [8560] kgf
		19600 [21280] lbf	17370 [18860] lbf
	ISO	91.0 [98.8] kN	80.3 [87.2] kN
		9280 [10080] kgf	8190 [8890] kgf
		20460 [22210] lbf	18060 [19600] lbf

[] : Power boost



4. WEIGHT













Item	R160LC-9		R160LCD-9	
	kg	lb	kg	lb
Upper structure assembly	7880	17370	←	
Main frame weld assembly	1470	3240	←	
Engine assembly	420	930	←	
Fan clutch assembly	45	100	←	
Main pump assembly	100	220	←	
Main control valve assembly	140	310	←	
Swing motor assembly	250	550	←	
Hydraulic oil tank assembly	165	360	←	
Fuel tank assembly	130	290	←	
Counterweight	2900	6390	←	
Cab assembly	500	1100	←	
Lower chassis assembly	6900	15210	7900	17420
Track frame weld assembly	2290	5050	2270	5000
Swing bearing	260	570	←	
Travel motor assembly	300	660	←	
Turning joint	60	130	←	
Track recoil spring	140	310	←	
Idler	160	350	←	
Carrier roller	20	45	←	
Track roller	40	90	←	
Track-chain assembly (600 mm standard triple grouser shoe)	1180	2600	←	
Front attachment assembly (5.1 m boom, 2.6 m arm, 0.7 m ³ SAE heaped bucket)	3020	6660	←	
5.1 m boom assembly	1040	2290	←	
2.6 m arm assembly	540	1190	←	
0.7 m ³ SAE heaped bucket	540	1190	←	
Boom cylinder assembly	155	340	←	
Arm cylinder assembly	180	400	←	
Bucket cylinder assembly	125	280	←	
Bucket control link assembly	120	265	←	
Dozer blade assembly	-	-	655	1445
Dozer blade cylinder assembly	-	-	-	-

5. LIFTING CAPACITIES

1) R160LC-9













(1) 5.1 m (16' 9") boom, 2.6 m (8' 6") arm equipped with 0.70 m³ (SAE heaped) bucket and 600 mm (24") triple grouser shoe and 2900 kg (6390 lb) counterweight.

-  : Rating over-front
-  : Rating over-side or 360 degree

Load point height		Load radius										At max. reach					
		1.5 m (5.0 ft)		3.0 m (10.0 ft)		4.5 m (15.0 ft)		6.0 m (20.0 ft)		7.5 m (25.0 ft)		Capacity		Reach			
														m (ft)			
7.5 m (25.0 ft)	kg														*3410	3190	6.11
	lb														*7520	7030	(20.0)
6.0 m (20.0 ft)	kg							*3040	*3040						*3380	2240	7.37
	lb							*6700	*6700						*7450	4940	(24.2)
4.5 m (15.0 ft)	kg							*3790	3150						3000	1820	8.11
	lb							*8360	6940						6610	4010	(26.6)
3.0 m (10.0 ft)	kg			*7930	*7930	*5330	4770	*4320	2990	*2830	2020				2730	1630	8.48
	lb			*17480	*17480	*11750	10520	*9520	6590	*6240	4450				6020	3590	(27.8)
1.5 m (5.0 ft)	kg			*8090	8060	*6680	4380	4670	2820	3250	1940				2650	1560	8.53
	lb			*17840	17770	*14730	9660	10300	6220	7170	4280				5840	3440	(28.0)
Ground Line	kg			*7880	7700	7150	4130	4520	2680	3190	1880				2750	1620	8.28
	lb			*17370	16980	15760	9110	9960	5910	7030	4140				6060	3570	(27.2)
-1.5 m (-5.0 ft)	kg	*6690	*6690	*10670	7660	7030	4020	4440	2610						3090	1830	7.69
	lb	*14750	*14750	*23520	16890	15500	8860	9790	5750						6810	4030	(25.2)
-3.0 m (-10.0 ft)	kg	*9970	*9970	*10310	7780	*6990	4050	4470	2640						*3770	2350	6.64
	lb	*21980	*21980	*22730	17150	*15410	8930	9850	5820						*8310	5180	(21.8)
-4.5 m (-15.0 ft)	kg			*7500	*7500	*4980	4230										
	lb			*16530	*16530	*10980	9330										

- Note
1. Lifting capacity are based on SAE J1097 and ISO 10567.
 2. Lifting capacity of the ROBEX series does not exceed 75% of tipping load with the machine on firm, level ground or 87% of full hydraulic capacity.
 3. The load point is a hook located on the back of the bucket.
 4. *indicates load limited by hydraulic capacity.

(2) 5.1 m (16' 9") hydraulic adjustable boom, 2.6 m (8' 6") arm equipped with 0.70 m³ (SAE heaped) bucket and 600 mm (24") triple grouser shoe and 2900 kg (6390 lb) counterweight.













Load point height		Load radius										At max. reach		
		1.5 m (5.0 ft)		3.0 m (10.0 ft)		4.5 m (15.0 ft)		6.0 m (20.0 ft)		7.5 m (25.0 ft)		Capacity		Reach
														m (ft)
6.0 m (20.0 ft)	kg lb											*3450 *7610	2160 4760	7.48 (24.5)
4.5 m (15.0 ft)	kg lb											2950 6500	1760 3880	8.20 (26.9)
3.0 m (10.0 ft)	kg lb						*4350 *9590	2980 6570	*3250 *7170	2000 4410	2680 5910	1570 3460	8.57 (28.1)	
1.5 m (5.0 ft)	kg lb			*6980 *15390	*6980 *15390	*6660 *14680	4350 9590	4690 10340	2790 6150	3260 7190	1920 4230	2610 5750	1510 3330	8.62 (28.3)
Ground Line	kg lb			*7040 *15520	*7040 *15520	7160 15790	4080 8990	4530 9990	2650 5840	3190 7030	1850 4080	2710 5970	1570 3460	8.37 (27.5)
-1.5 m (-5.0 ft)	kg lb	*6030 *13290	*6030 *13290	*9960 *21960	7580 16710	7040 15520	3970 8750	4450 9810	2580 5690			3050 6720	1780 3920	7.78 (25.5)
-3.0 m (-10.0 ft)	kg lb	*9490 *20920	*9490 *20920	*9860 *21740	7730 17040	*6740 *14860	4010 8840	4490 9900	2610 5750			*3350 *7390	2290 5050	6.76 (22.2)
-4.5 m (-15.0 ft)	kg lb			*6840 *15080	*6840 *15080	*4560 *10050	4220 9300							

2) R160LCD-9

(1) 5.1 m (16' 9") boom, 2.6 m (8' 6") arm equipped with 0.7 m³ (SAE heaped) bucket and 600 mm (24") triple grouser shoe and 2900 kg (6390 lb) counterweight.













•  : Rating over-front

•  : Rating over-side or 360 degree

Load point height		Load radius										At max. reach					
		1.5 m (5.0 ft)		3.0 m (10.0 ft)		4.5 m (15.0 ft)		6.0 m (20.0 ft)		7.5 m (25.0 ft)		Capacity		Reach			
														kg	lb	m (ft)	
7.5 m (25.0 ft)	kg														*3410	3350	6.11
	lb														*7520	7390	(20.0)
6.0 m (20.0 ft)	kg							*3040	*3040						*3380	2370	7.37
	lb							*6700	*6700						*7450	5220	(24.2)
4.5 m (15.0 ft)	kg							*3790	3310						3340	1940	8.11
	lb							*8360	7300						7360	4280	(26.6)
3.0 m (10.0 ft)	kg			*7930	*7930	*5330	5000	*4320	3160	*2830	2140				3040	1730	8.48
	lb			*17480	*17480	*11750	11020	*9520	6970	*6240	4720				6700	3810	(27.8)
1.5 m (5.0 ft)	kg			*8090	*8090	*6680	4620	*4950	2980	3620	2070				2960	1670	8.53
	lb			*17840	*17840	*14730	10190	*10910	6570	7980	4560				6530	3680	(28.0)
Ground Line	kg			*7880	*7880	*7520	4360	5010	2840	*3490	2010				3080	1730	8.28
	lb			*17370	*17370	*16580	9610	11050	6260	*7690	4430				6790	3810	(27.2)
-1.5 m (-5.0 ft)	kg	*6690	*6690	*10670	8080	*7650	4260	4930	2780						3450	1950	7.69
	lb	*14750	*14750	*23520	17810	*16870	9390	10870	6130						7610	4300	(25.2)
-3.0 m (-10.0 ft)	kg	*9970	*9970	*10310	8200	*6990	4280	*4900	2800						*3770	2500	6.64
	lb	*21980	*21980	*22730	18080	*15410	9440	*10800	6170						*8310	5510	(21.8)
-4.5 m (-15.0 ft)	kg			*7500	*7500	*4980	4460										
	lb			*16530	*16530	*10980	9830										

- Note
1. Lifting capacity are based on SAE J1097 and ISO 10567.
 2. Lifting capacity of the ROBEX series does not exceed 75% of tipping load with the machine on firm, level ground or 87% of full hydraulic capacity.
 3. The load point is a hook located on the back of the bucket.
 4. *indicates load limited by hydraulic capacity.

(2) 5.1 m (16' 9") hydraulic adjustable boom, 2.6 m (8' 6") arm equipped with 0.7 m³ (SAE heaped) bucket and 600 mm (24") triple grouser shoe and 2900 kg (6390 lb) counterweight.

Load point height		Load radius										At max. reach		
		1.5 m (5.0 ft)		3.0 m (10.0 ft)		4.5 m (15.0 ft)		6.0 m (20.0 ft)		7.5 m (25.0 ft)		Capacity		Reach
														
6.0 m (20.0 ft)	kg lb											*3450 *7610	2280 5030	7.48 (24.5)
4.5 m (15.0 ft)	kg lb											3280 7230	1870 4120	8.20 (26.9)
3.0 m (10.0 ft)	kg lb							*4350 *9590	3150 6940	*3250 *7170	2120 4670	2990 6590	1680 3700	8.57 (28.1)
1.5 m (5.0 ft)	kg lb			*6980 *15390	*6980 *15390	*6660 *14680	4590 10120	*4920 *10850	2960 6530	3630 8000	2040 4500	2920 6440	1620 3570	8.62 (28.3)
Ground Line	kg lb			*7040 *15520	*7040 *15520	*7420 *16360	4310 9500	5020 11070	2810 6190	3560 7850	1980 4370	3030 6680	1680 3700	8.37 (27.5)
-1.5 m (-5.0 ft)	kg lb	*6030 *13290	*6030 *13290	*9960 *21960	8010 17660	*7480 *16490	4210 9280	4940 10890	2740 6040			3400 7500	1900 4190	7.78 (25.5)
-3.0 m (-10.0 ft)	kg lb	*9490 *20920	*9490 *20920	*9860 *21740	8150 17970	*6740 *14860	4250 9370	*4700 *10360	2780 6130			*3350 *7390	2430 5360	6.76 (22.2)
-4.5 m (-15.0 ft)	kg lb			*6840 *15080	*6840 *15080	*4560 *10050	4460 9830							

6. BUCKET SELECTION GUIDE

1) GENERAL BUCKET

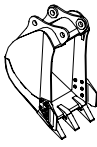
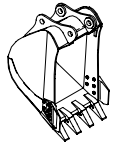
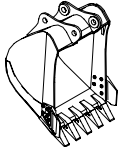
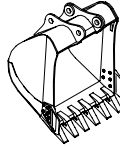
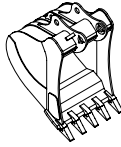
				
0.39 m ³ SAE heaped bucket	0.50 m ³ SAE heaped bucket	0.64, 0.70 m ³ SAE heaped bucket	0.89 m ³ SAE heaped bucket	◆0.69 m ³ SAE heaped bucket

Capacity		Width		Weight	Recommendation				
					5.1 m (16' 9") Mono boom			5.1 m (16' 9") Hyd adjustable boom	
SAE heaped	CECE heaped	Without side cutter	With side cutter		2.2 m arm (7' 3")	2.6 m arm (8' 6")	3.1 m arm (10' 2")	2.2 m arm (7' 3")	2.6 m arm (8' 6")
0.39 m ³ (0.51 yd ³)	0.34 m ³ (0.44 yd ³)	620 mm (24.4")	740 mm (29.1")	410 kg (900 lb)					
0.50 m ³ (0.65 yd ³)	0.44 m ³ (0.58 yd ³)	760 mm (29.9")	880 mm (34.6")	470 kg (1040 lb)					
0.64 m ³ (0.84 yd ³)	0.55 m ³ (0.72 yd ³)	920 mm (36.2")	1040 mm (40.9")	510 kg (1120 lb)					
0.70 m ³ (0.92 yd ³)	0.60 m ³ (0.78 yd ³)	990 mm (39.0")	1110 mm (43.7")	540 kg (1190 lb)					
0.89 m ³ (1.16 yd ³)	0.77 m ³ (1.01 yd ³)	1220 mm (48.0")	1340 mm (52.8")	610 kg (1340 lb)					
◆0.69 m ³ (0.90 yd ³)	0.62 m ³ (0.81 yd ³)	990 mm (39.0")	-	700 kg (1540 lb)					

◆ : Heavy duty bucket

 Applicable for materials with density of 2000 kg/m³ (3370 lb/yd³) or less

 Applicable for materials with density of 1600 kg/m³ (2700 lb/yd³) or less

 Applicable for materials with density of 1100 kg/m³ (1850 lb/yd³) or less

7. UNDERCARRIAGE

1) TRACKS

X-leg type center frame is integrally welded with reinforced box-section track frames. The design includes dry tracks, lubricated rollers, idlers, sprockets, hydraulic track adjusters with shock absorbing springs and assembled track-type tractor shoes with triple grousers.

2) TYPES OF SHOES

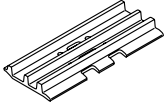
Model	Shapes		Triple grouser		
					
R160LC-9	Shoe width	mm (in)	500 (20)	* 600 (24)	700 (28)
	Operating weight	kg (lb)	17550 (38690)	17800 (39240)	18050 (39790)
	Ground pressure	kgf/cm ² (psi)	0.51 (7.25)	0.43 (6.11)	0.38 (5.40)
	Overall width	mm (ft-in)	2490 (8' 2")	2590 (8' 6")	2690 (8' 10")
R160LCD-9	Shoe width	mm (in)	500 (20)	* 600 (24)	700 (28)
	Operating weight	kg (lb)	18550 (40900)	18800 (41450)	19050 (42000)
	Ground pressure	kgf/cm ² (psi)	0.54 (7.68)	0.46 (6.54)	0.40 (5.69)
	Overall width	mm (ft-in)	2490 (8' 2")	2590 (8' 6")	2690 (8' 10")

* : Standard

3) NUMBER OF ROLLERS AND SHOES ON EACH SIDE

Item	Quantity
	R160LC/LCD-9
Carrier rollers	2 EA
Track rollers	7 EA
Track shoes	49 EA

4) SELECTION OF TRACK SHOE

Suitable track shoes should be selected according to operating conditions.

Method of selecting shoes

Confirm the category from the list of applications in **table 2**, then use **table 1** to select the shoe. Wide shoes (Categories B) have limitations on applications. Before using wide shoes, check the precautions, then investigate and study the operating conditions to confirm if these shoes are suitable.

Select the narrowest shoe possible to meet the required flotation and ground pressure. Application of wider shoes than recommendations will cause unexpected problem such as bending of shoes, crack of link, breakage of pin, loosening of shoe bolts

※ **Table 1**

Track shoe	Specification	Category
600 mm triple grouser	Standard	A
500 mm triple grouser	Option	A
700 mm triple grouser	Option	B

※ **Table 2**

Category	Applications	Applications
A	Rocky ground, river beds, normal soil	<ul style="list-style-type: none"> Travel at low speed on rough ground with large obstacles such as boulders or fallen trees

8. SPECIFICATIONS FOR MAJOR COMPONENTS

1) ENGINE

Item	Specification
Model	Mitsubishi D04FD-TAA
Type	4-cycle turbocharged charge air cooled diesel engine
Cooling method	Water cooling
Number of cylinders and arrangement	4 cylinders, in-line
Firing order	1-3-4-2
Combustion chamber type	Direct injection type
Cylinder bore × stroke	102 × 130 mm (4.02" × 5.12")
Piston displacement	4250 cc (260 cu in)
Compression ratio	16.5 : 1
Rated gross horse power (SAE J1995)	126 Hp (94 kW) at 2000 rpm
Maximum torque	47.7 kgf · m (345 lbf · ft) at 1800 rpm
Engine oil quantity	17.5 l (4.6 U.S. gal)
Dry weight	420 kg (930 lb)
High idling speed	2100 ± 50 rpm
Low idling speed	950 ± 100 rpm
Rated fuel consumption	170.6 g/Hp · hr at 2000 rpm
Starting motor	24 V-5.0 kW
Alternator	24 V-50 A
Battery	2 × 12 V × 80 Ah

2) MAIN PUMP

Item	Specification
Type	Variable displacement tandem axis piston pumps
Capacity	2 × 80 cc/rev
Maximum pressure	350 kgf/cm ² (4980 psi) [380 kgf/cm ² (5400 psi)]
Rated oil flow	2 × 160 l /min (42.3 U.S. gpm / 35.2 U.K. gpm)
Rated speed	2000 rpm

[] : Power boost

3) GEAR PUMP

Item	Specification
Type	Fixed displacement gear pump single stage
Capacity	15cc/rev
Maximum pressure	40 kgf/cm ² (570 psi)
Rated oil flow	30 l /min (7.9 U.S. gpm / 6.6 U.K. gpm)

4) MAIN CONTROL VALVE

Item	Specification
Type	11 spools two-block
Operating method	Hydraulic pilot system
Main relief valve pressure	350 kgf/cm ² (4980 psi) [380 kgf/cm ² (5400 psi)]
Overload relief valve pressure	400 kgf/cm ² (5690 psi)

[] : Power boost

5) SWING MOTOR

Item	Specification
Type	Two fixed displacement axial piston motor
Capacity	117.8 cc/rev
Relief pressure	285 kgf/cm ² (4054 psi)
Braking system	Automatic, spring applied hydraulic released
Braking torque	59 kgf · m (427 lbf · ft)
Brake release pressure	33~50 kgf/cm ² (469~711 psi)
Reduction gear type	2 - stage planetary

6) TRAVEL MOTOR

Item	Specification
Type	Variable displacement axial piston motor
Relief pressure	350 kgf/cm ² (4980 psi)
Reduction gear type	Planetary & differential type
Braking system	Automatic, spring applied hydraulic released
Brake release pressure	11 kgf/cm ² (156 psi)
Braking torque	49.3 kgf · m (357 lbf · ft)

7) CYLINDER

Item		Specification
Boom cylinder	Bore dia × Rod dia × Stroke	∅ 115 × ∅ 80 × 1090 mm
	Cushion	Extend only
Arm cylinder	Bore dia × Rod dia × Stroke	∅ 120 × ∅ 85 × 1355 mm
	Cushion	Extend and retract
Bucket cylinder	Bore dia × Rod dia × Stroke	∅ 115 × ∅ 75 × 995 mm
	Cushion	Extend only

※ Discoloration of cylinder rod can occur when the friction reduction additive of lubrication oil spreads on the rod surface.

※ Discoloration does not cause any harmful effect on the cylinder performance.

8) SHOE

Item		Width	Ground pressure	Link quantity	Overall width
R160LC-9	Option	500 mm (20")	0.50 kgf/cm ² (7.11 psi)	49	2490 mm (8' 2")
	Standard	600 mm (24")	0.42 kgf/cm ² (5.97 psi)	49	2590 mm (8' 6")
	Option	700 mm (28")	0.37 kgf/cm ² (5.26 psi)	49	2690 mm (8' 10")

9) BUCKET

Item	Capacity		Tooth quantity	Width	
	SAE heaped	CECE heaped		Without side cutter	With side cutter
R160LC-9	0.39 m ³ (0.51 yd ³)	0.34 m ³ (0.44 yd ³)	3	620 mm (24.4")	740 mm (29.1")
	0.50 m ³ (0.65 yd ³)	0.44 m ³ (0.58 yd ³)	4	760 mm (29.9")	880 mm (34.6")
	0.64 m ³ (0.84 yd ³)	0.55 m ³ (0.72 yd ³)	5	920 mm (36.2")	1040 mm (40.9")
	0.70 m ³ (0.92 yd ³)	0.60 m ³ (0.78 yd ³)	5	990 mm (39.0")	1110 mm (43.7")
	0.89 m ³ (1.16 yd ³)	0.77 m ³ (1.01 yd ³)	6	1220 mm (48.0")	1340 mm (52.8")
	◆0.69 m ³ (0.90 yd ³)	0.62 m ³ (0.81 yd ³)	5	990 mm (39.0")	-

◆ : Heavy duty bucket

9. RECOMMENDED OILS

Use only oils listed below or equivalent.
Do not mix different brand oil.

Service point	Kind of fluid	Capacity l (U.S. gal)	Ambient temperature °C (°F)							
			-20 (-4)	-10 (14)	0 (32)	10 (50)	20 (68)	30 (86)	40 (104)	
Engine oil pan	Engine oil	17.5 (4.6)				SAE 30				
			SAE 10W							
			SAE 10W-30							
			SAE 15W-40							
Swing drive	Grease	1.2 (0.32)	NLGI NO.1							
			NLGI NO.2							
Swing drive	Gear oil	5.0 (1.3)	SAE 85W-140							
Final drive		5.8 × 2 (1.53 × 2)								
Hydraulic tank	Hydraulic oil	Tank: 160 (42.3)	ISO VG 32							
		System: 240 (63.4)	ISO VG 46							
			ISO VG 68							
Fuel tank	Diesel fuel	260 (68.7)	ASTM D975 NO.1							
			ASTM D975 NO.2							
Fitting (Grease nipple)	Grease	As required	NLGI NO.1							
			NLGI NO.2							
Radiator (Reservoir tank)	Mixture of antifreeze and water 50 : 50	15.5 (4.1)	Ethylene glycol base permanent type							

SAE : Society of Automotive Engineers
API : American Petroleum Institute
ISO : International Organization for Standardization
NLGI : National Lubricating Grease Institute
ASTM : American Society of Testing and Material