

GROUP 7 WORK EQUIPMENT

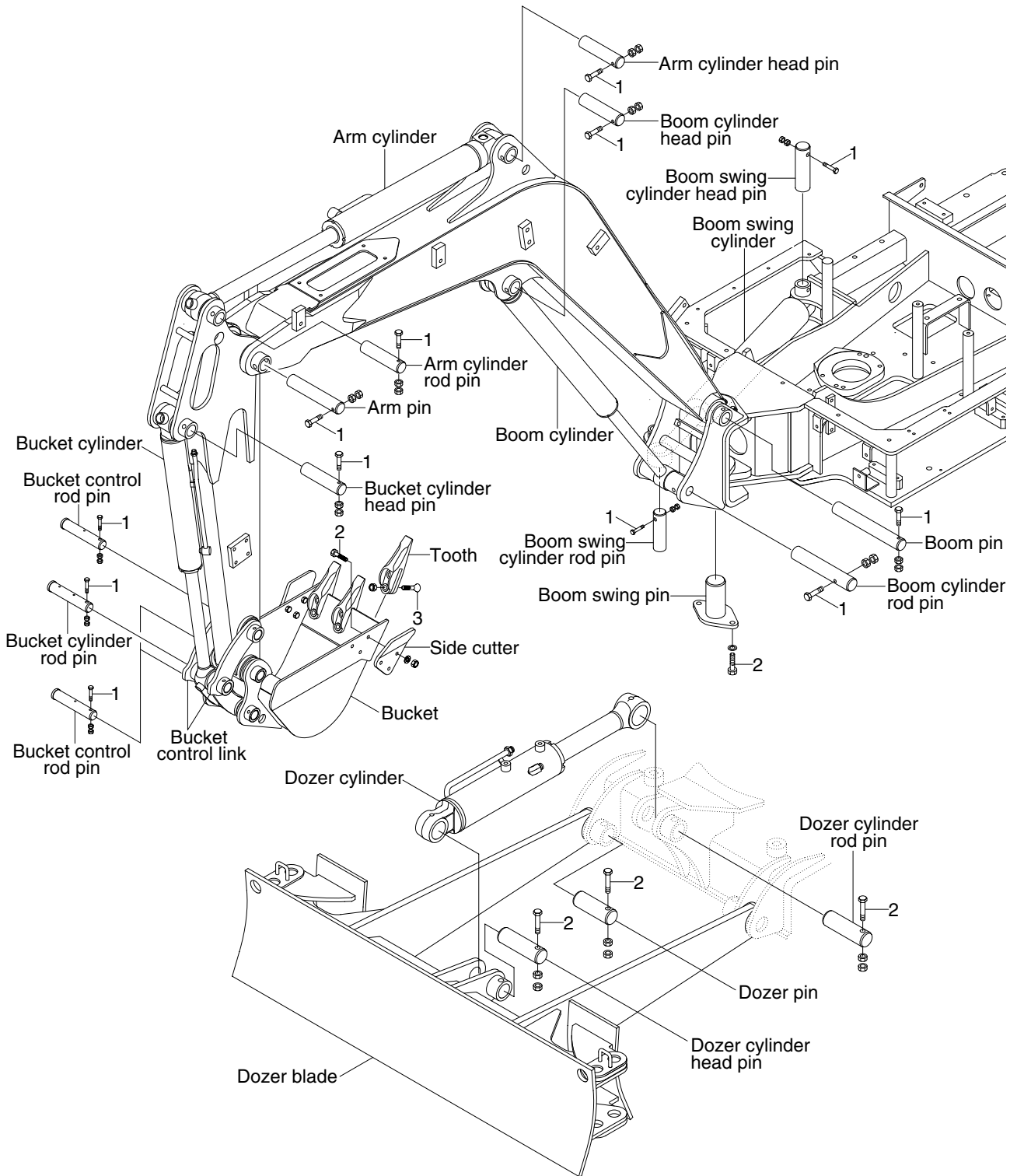

1698CM11

· Tightening torque

Item	Size	kgf · m	lbf · ft
1	M10 × 1.5	6.0 ± 1.4	43.4 ± 10.1
2	M12 × 1.75	12.8 ± 3.0	92.6 ± 21.7

Item	Size	kgf · m	lbf · ft
3	M16 × 1.5	31.3 ± 4.7	226 ± 34