

## GROUP 9 BOOM, ARM AND BUCKET CYLINDERS

### 1. REMOVAL AND INSTALL

#### 1) BUCKET CYLINDER

##### (1) Removal

- ※ Expand the arm and bucket fully, lower the work equipment to the ground and stop the engine.
- ※ Operate the control levers and pedals several times to release the remaining pressure in the hydraulic piping.

**▲ Loosen the breather slowly to release the pressure inside the hydraulic tank. Escaping fluid under pressure can penetrate the skin causing serious injury.**

- ※ Fit blind plugs in the hoses after disconnecting them, to prevent dirt or dust from entering.

① Set block between bucket cylinder and arm.

② Remove bolt (2), nut (3) and pull out pin (1).

- ※ Tie the rod with wire to prevent it from coming out.

③ Disconnect bucket cylinder hoses (4) and put plugs (5) on cylinder pipe.



13031GE18

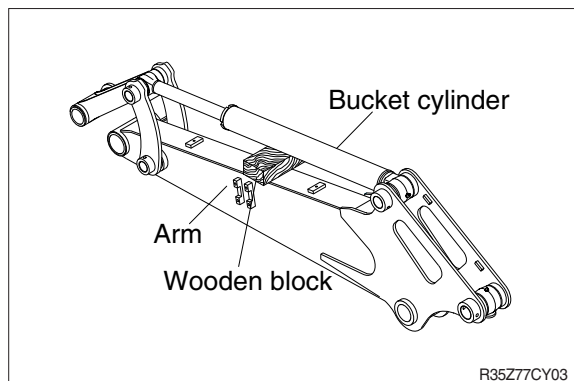

R35Z77CY03

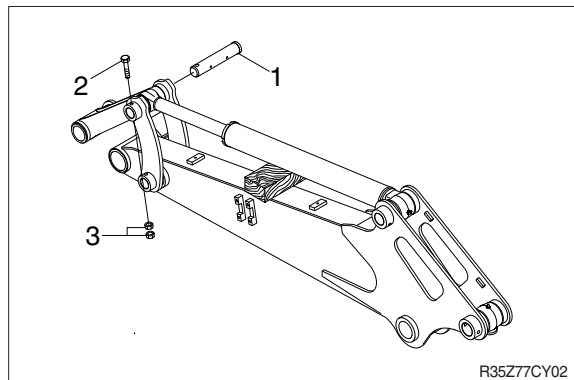

R35Z77CY02

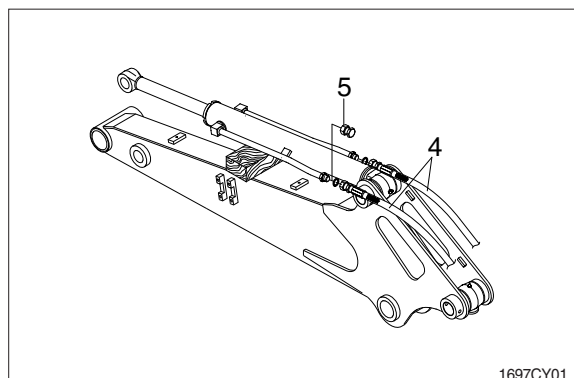

1697CY01

- ④ Sling bucket cylinder assembly (9) and remove bolt (6) and nut (7) then pull out pin (8).
- ⑤ Remove bucket cylinder assembly (9).
  - Weight : 11 kg (24 lb)

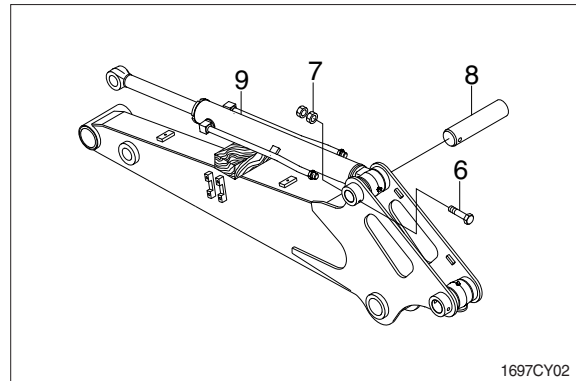

## (2) Install

- ① Carry out installation in the reverse order to removal.
- ▲ When aligning the mounting position of the pin, do not insert your fingers in the pin hole.**
- ※ Bleed the air from the bucket cylinder.
  - ※ Confirm the hydraulic oil level and check the hydraulic oil leak or not.

## 2) ARM CYLINDER

### (1) Removal

- ※ Expand the arm and bucket fully, lower the work equipment to the ground and stop the engine.
- ※ Operate the control levers and pedals several times to release the remaining pressure in the hydraulic piping.

**▲ Loosen the breather slowly to release the pressure inside the hydraulic tank.**

**▲ Escaping fluid under pressure can penetrate the skin causing serious injury.**

- ※ Fit blind plugs in the hoses after disconnecting them, to prevent dirt or dust from entering.

① Set block between arm cylinder and boom.

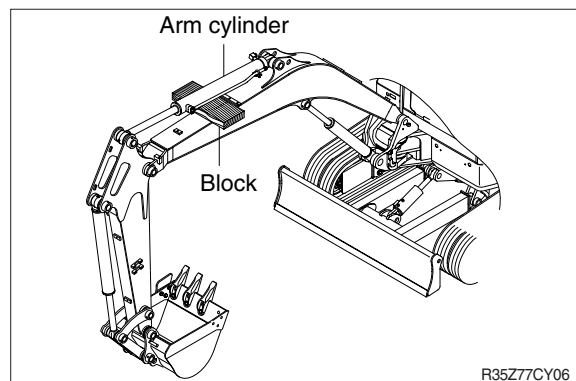

② Remove bolt and nut (2) and pull out pin (1).

- ※ Tie the rod with wire to prevent it from coming out.

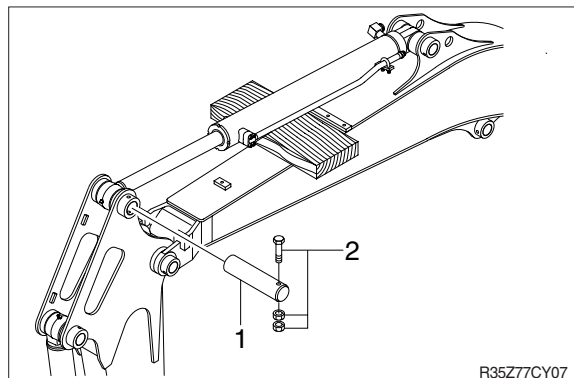

③ Disconnect arm cylinder hoses (4) and put plugs on cylinder pipe.

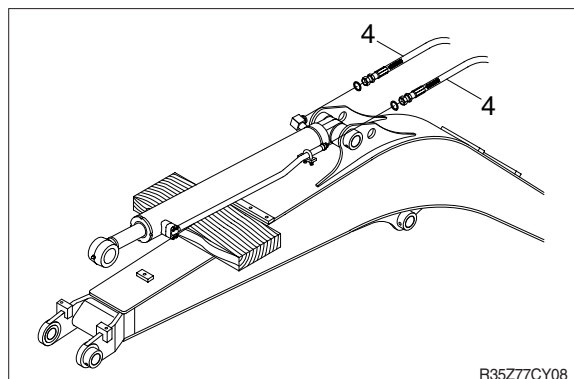

- ⑤ Sling arm assembly (8) and remove bolt and nut (7) then pull out pin (6).
- ⑥ Remove arm cylinder assembly (8).
  - Weight : 15 kg (33 lb)

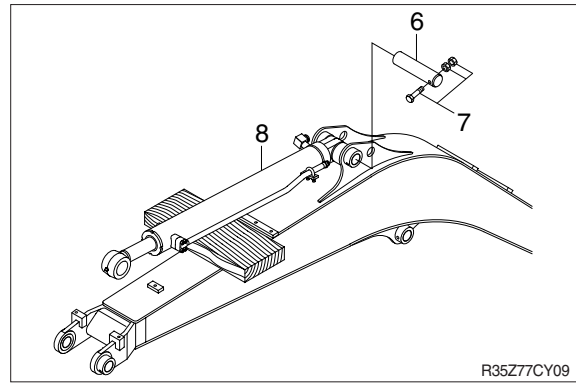

## (2) Install

- ① Carry out installation in the reverse order to removal.
- ▲ When aligning the mounting position of the pin, do not insert your fingers in the pin hole.**
- ※ Bleed the air from the arm cylinder.
  - ※ Confirm the hydraulic oil level and check the hydraulic oil leak or not.

### 3) BOOM CYLINDER

#### (1) Removal

- ※ Expand the arm and bucket fully, lower the work equipment to the ground and stop the engine.
- ※ Operate the control levers and pedals several times to release the remaining pressure in the hydraulic piping.

**▲ Loosen the breather slowly to release the pressure inside the hydraulic tank.**

**▲ Escaping fluid under pressure can penetrate the skin causing serious injury.**

- ※ Fit blind plugs in the hoses after disconnecting them, to prevent dirt or dust from entering.

① Sling boom cylinder assembly.

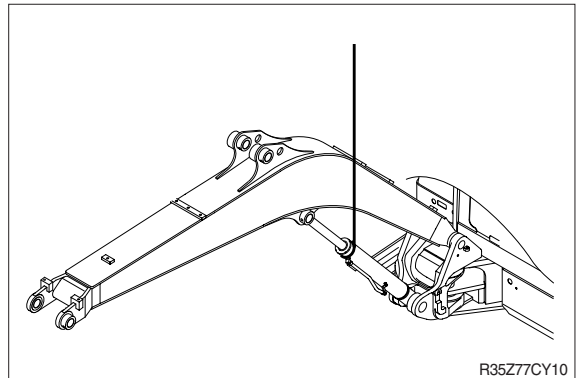

③ Remove bolt and nut (2) and pull out pin (1).

- ※ Tie the rod with wire to prevent it from coming out.

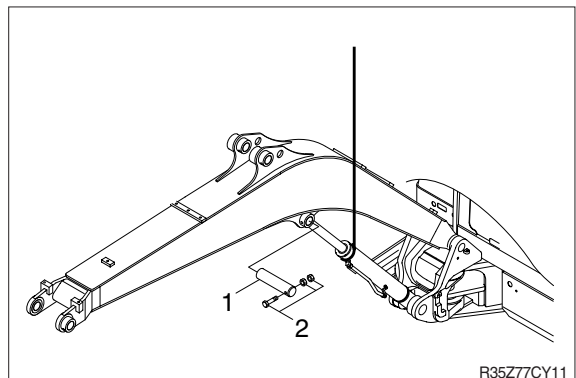

④ Lower the boom cylinder assembly (3) on a stand.

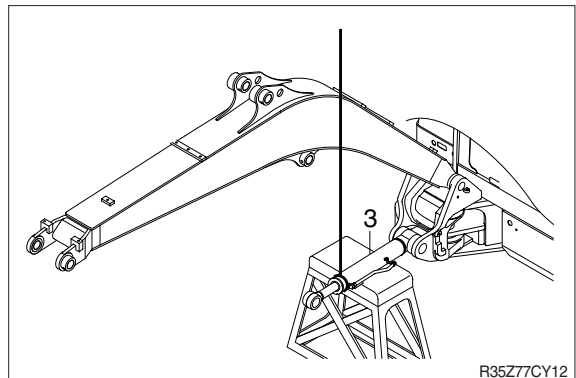

- ⑤ Disconnect boom cylinder hoses(4) and put plugs on cylinder pipe.

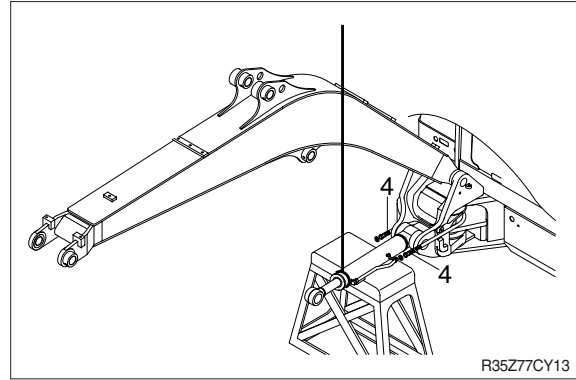

- ⑥ Remove bolt (6) and pull out pin (5).  
⑦ Remove boom cylinder assembly (3).  
· Weight : 17 kg (37 lb)

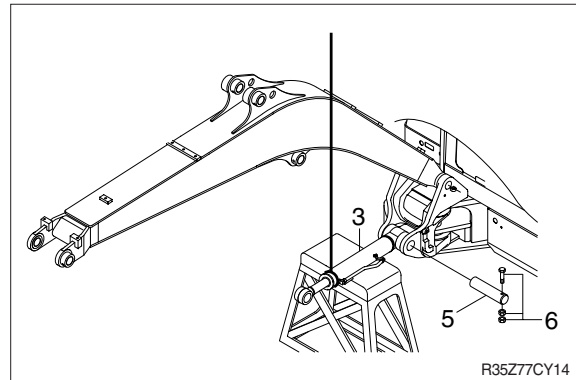

## (2) Install

- ① Carry out installation in the reverse order to removal.

**▲ When aligning the mounting position of the pin, do not insert your fingers in the pin hole.**

- ※ Bleed the air from the boom cylinder.
- ※ Confirmed the hydraulic oil level and check the hydraulic oil leak or not.

## 2. DISASSEMBLY AND ASSEMBLY

### 1) STRUCTURE

#### (1) Bucket cylinder

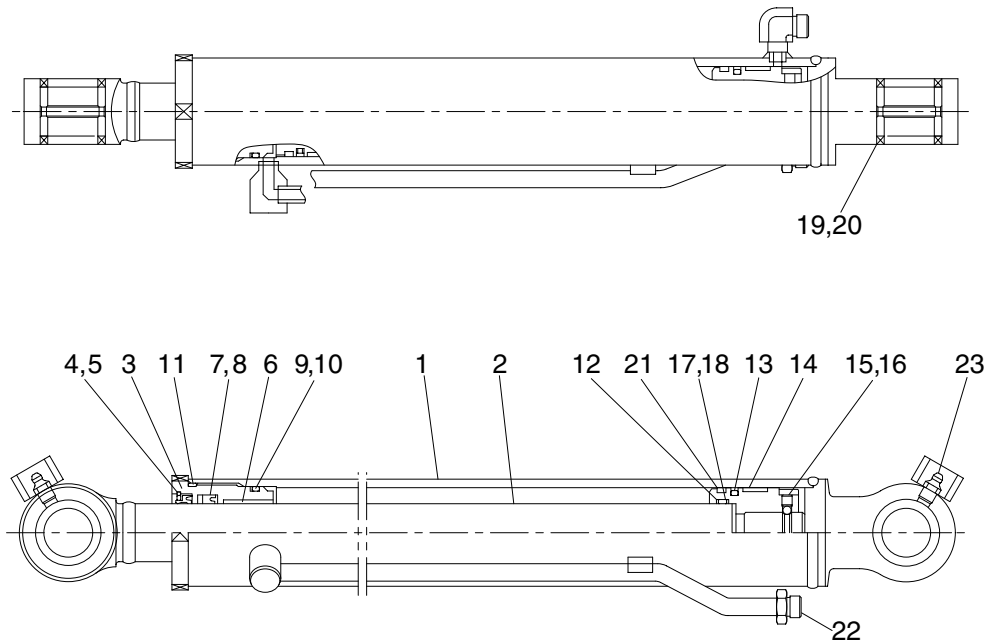

1697CY03

- |   |                |    |              |    |               |
|---|----------------|----|--------------|----|---------------|
| 1 | Tube assembly  | 9  | O-ring       | 17 | O-ring        |
| 2 | Rod assembly   | 10 | Back-up ring | 18 | Back up ring  |
| 3 | Gland          | 11 | O-ring       | 19 | Pin bushing   |
| 4 | Dust wiper     | 12 | Piston       | 20 | Dust seal     |
| 5 | Retaining ring | 13 | Piston seal  | 21 | Dust ring     |
| 6 | Bushing        | 14 | Wear ring    | 22 | O-ring        |
| 7 | Rod seal       | 15 | Set screw    | 23 | Grease nipple |
| 8 | Back-up ring   | 16 | Steel ball   |    |               |

## (2) Arm cylinder

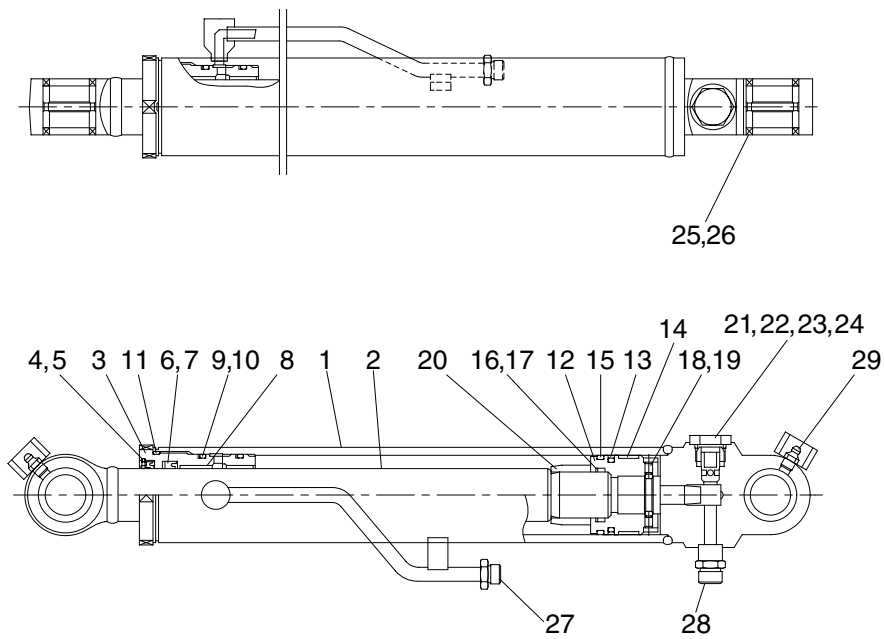

1697CY04

1	Tube assembly	11	O-ring	21	Check valve
2	Rod assembly	12	Piston	22	Spring
3	Gland	13	Piston seal	23	O-ring
4	Dust wiper	14	Wear ring	24	Plug
5	Retaining ring	15	Dust ring	25	Pin bushing
6	Rod seal	16	O-ring	26	Dust seal
7	Back-up ring	17	Back up ring	27	O-ring
8	Bushing	18	Set screw	28	O-ring
9	O-ring	19	Steel ball	29	Grease nipple
10	Back-up ring	20	Cushion ring		

### (3) Boom cylinder

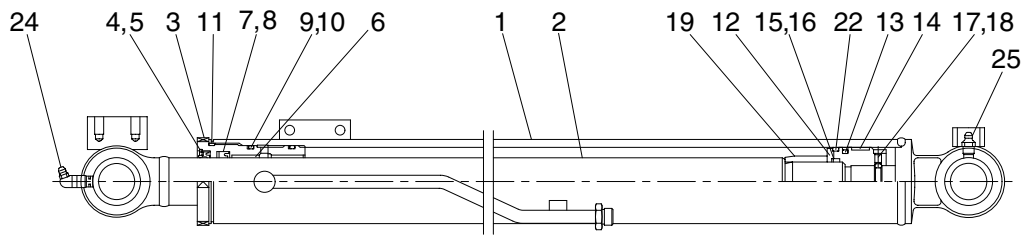
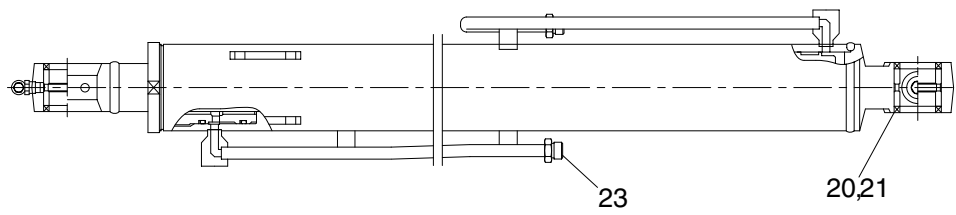

1697CY18

- |   |                |    |              |    |               |
|---|----------------|----|--------------|----|---------------|
| 1 | Tube assembly  | 10 | Back-up ring | 19 | Cushion ring  |
| 2 | Rod assembly   | 11 | O-ring       | 20 | Pin bushing   |
| 3 | Gland          | 12 | Piston       | 21 | Dust seal     |
| 4 | Dust wiper     | 13 | Piston seal  | 22 | Dust ring     |
| 5 | Retaining ring | 14 | Wear ring    | 23 | O-ring        |
| 6 | Bushing        | 15 | O-ring       | 24 | Grease nipple |
| 7 | Rod seal       | 16 | Back up ring | 25 | Grease nipple |
| 8 | Back-up ring   | 17 | Set screw    |    |               |
| 9 | O-ring         | 18 | Steel ball   |    |               |

#### (4) Dozer cylinder

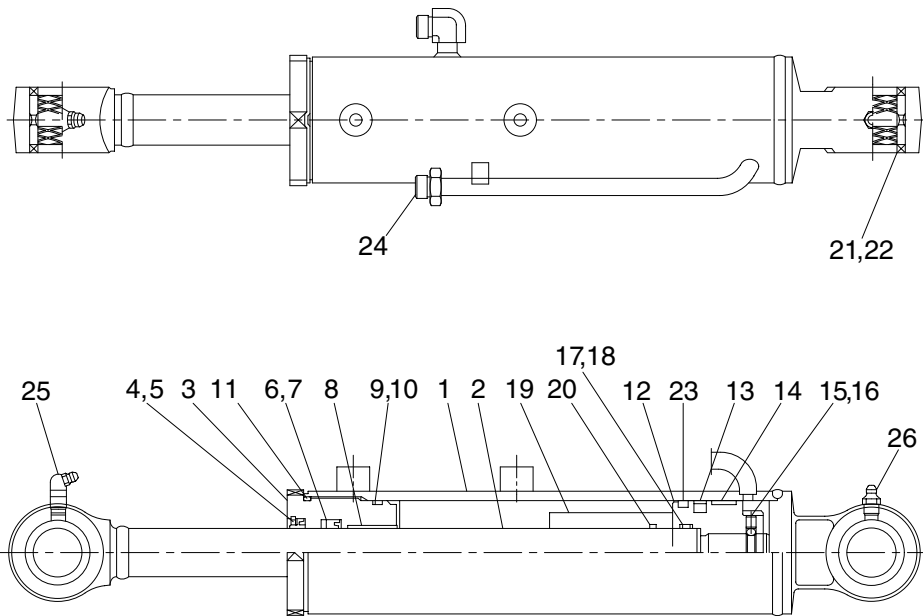

- |   |                |    |              |    |               |
|---|----------------|----|--------------|----|---------------|
| 1 | Tube assembly  | 10 | Back-up ring | 19 | Spacer        |
| 2 | Rod assembly   | 11 | O-ring       | 20 | O-ring        |
| 3 | Gland          | 12 | Piston       | 21 | Bushing       |
| 4 | Dust wiper     | 13 | Piston seal  | 22 | Dust seal     |
| 5 | Retaining ring | 14 | Wear ring    | 23 | Dust ring     |
| 6 | Rod seal       | 15 | Set screw    | 24 | O-ring        |
| 7 | Back-up ring   | 16 | Steel ball   | 25 | Grease nipple |
| 8 | DU bushing     | 17 | O-ring       | 26 | Grease nipple |
| 9 | O-ring         | 18 | Back-up ring |    |               |

1697CY19

(5) Boom swing cylinder

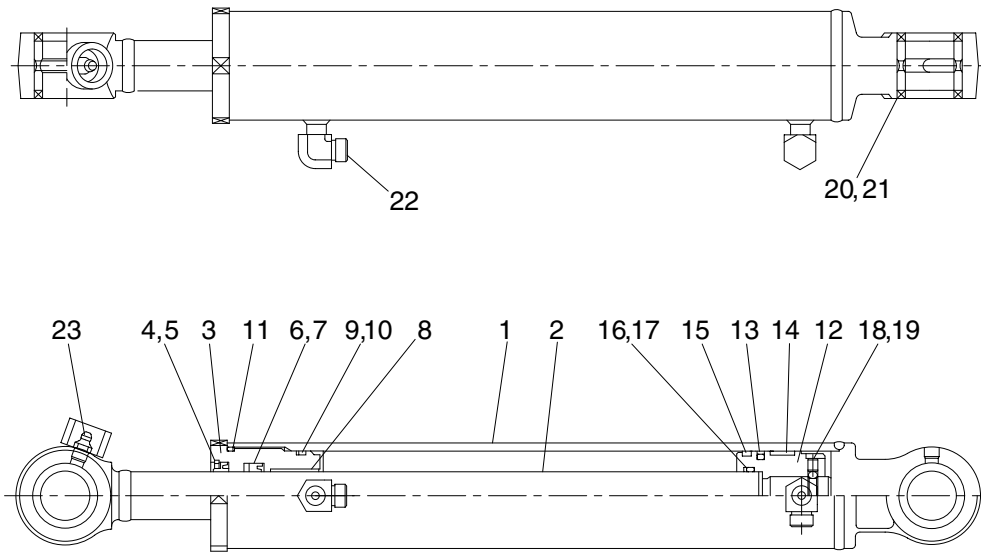

1697CY20

- |   |                |    |              |    |               |
|---|----------------|----|--------------|----|---------------|
| 1 | Tube assembly  | 9  | O-ring       | 17 | Back up ring  |
| 2 | Rod assembly   | 10 | Back-up ring | 18 | Set screw     |
| 3 | Gland          | 11 | O-ring       | 19 | Steel ball    |
| 4 | Dust wiper     | 12 | Piston       | 20 | Pin bushing   |
| 5 | Retaining ring | 13 | Piston seal  | 21 | Dust seal     |
| 6 | Rod seal       | 14 | Wear ring    | 22 | O-ring        |
| 7 | Back-up ring   | 15 | Dust ring    | 23 | Grease nipple |
| 8 | DU bushing     | 16 | O-ring       |    |               |

## (6) Extension cylinder

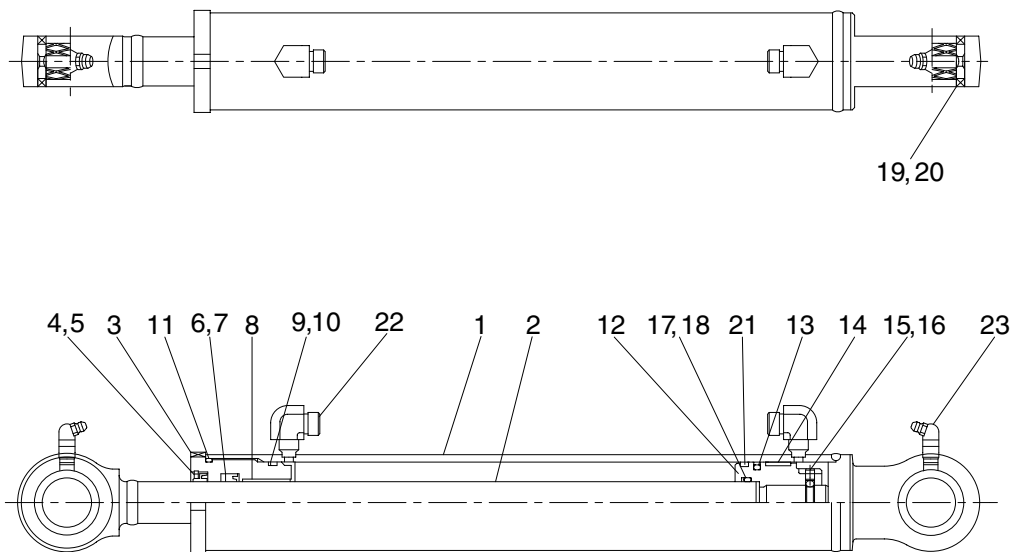

19,20

1697CY21

- |   |                |    |              |    |               |
|---|----------------|----|--------------|----|---------------|
| 1 | Tube assembly  | 9  | O-ring       | 17 | O-ring        |
| 2 | Rod assembly   | 10 | Back-up ring | 18 | Back-up ring  |
| 3 | Gland          | 11 | O-ring       | 19 | Pin bushing   |
| 4 | Dust wiper     | 12 | Piston       | 20 | Dust seal     |
| 5 | Retaining ring | 13 | Piston seal  | 21 | Dust ring     |
| 6 | Rod seal       | 14 | Wear ring    | 22 | O-ring        |
| 7 | Back-up ring   | 15 | Set screw    | 23 | Grease nipple |
| 8 | DU bushing     | 16 | Steel ball   |    |               |

## 2) TOOLS AND TIGHTENING TORQUE

### (1) Tools

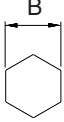
Tool name	Remark	
Allen wrench	8	
	3	
Spanner	M22	
Hook spanner	Suitable size (80~120 mm)	
(-) Driver	Small and large sizes	
Torque wrench	Capable of tightening with the specified torques	

### (2) Tightening torque

Part name		Item	Size	Torque	
				kgf · m	lbf · ft
Gland	Boom cylinder	3	M65	52 ± 5.0	376 ± 36.2
	Arm cylinder	3	M65	52 ± 5.0	376 ± 36.2
	Bucket cylinder	3	M60	48 ± 5.0	347 ± 36.2
	Dozer cylinder	3	M70	56 ± 5.0	405 ± 36.2
	Boom swing cylinder	3	M60	48 ± 4.8	347 ± 34.7
	Extension cylinder	3	M55	44 ± 4.5	318 ± 32.5
Piston	Boom cylinder	12	M28	70 ± 7.0	506 ± 50.6
	Arm cylinder	12	M28	70 ± 7.0	506 ± 50.6
	Bucket cylinder	12	M24	60 ± 6.0	434 ± 43.4
	Dozer cylinder	12	M24	60 ± 6.0	434 ± 43.4
	Boom swing cylinder	12	M24	60 ± 6.0	434 ± 43.4
	Extension cylinder	12	M20	50 ± 5.0	362 ± 36.2

### 3) DISASSEMBLY

※ Procedures are based on the boom cylinder.

#### (1) Remove cylinder head and piston rod

① Hold the clevis section of the tube in a vise.

※ Use mouth pieces so as not to damage the machined surface of the cylinder tube. Do not make use of the outside piping as a locking means.

② Pull out rod assembly (2) about 200 mm (7.1 in). Because the rod assembly is rather heavy, finish extending it with air pressure after the oil draining operation.

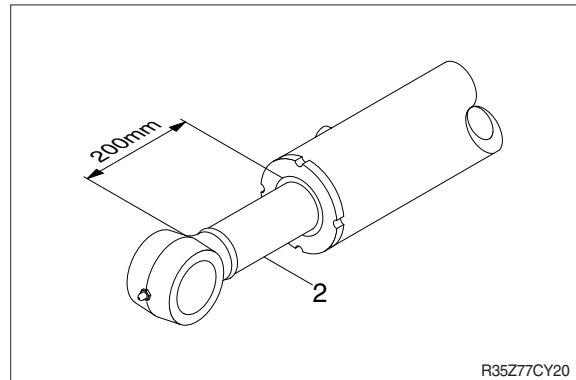

③ Loosen and remove the gland (3) by hook spanner.

※ Cover the extracted rod assembly (2) with rag to prevent it from being accidentally damaged during operation.

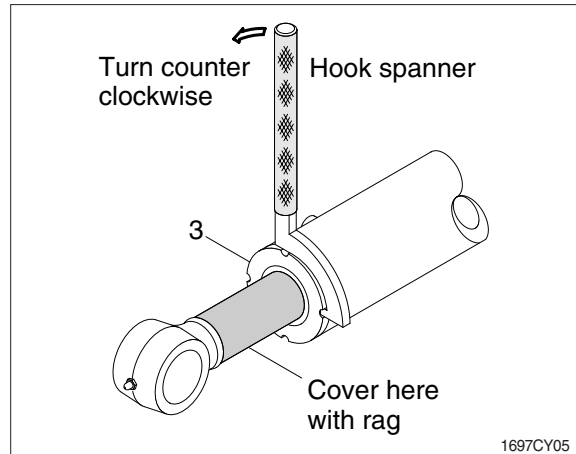

④ Draw out cylinder head and rod assembly together from tube assembly (1).

※ Since the rod assembly is heavy in this case, lift the tip of the rod assembly (2) with a crane or some means and draw it out. However, when rod assembly (2) has been drawn out to approximately two thirds of its length, lift it in its center to draw it completely.

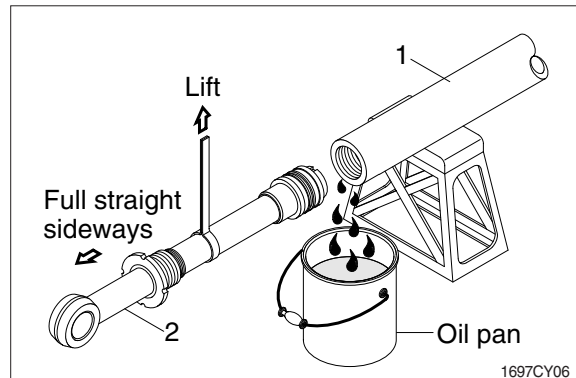

Note that the plated surface of rod assembly (2) is to be lifted. For this reason, do not use a wire sling and others that may damage it, but use a strong cloth belt or a rope.

- ⑤ Place the removed rod assembly (2) on a wooden V-block that is set level.
- ※ Cover a V-block with soft rag.

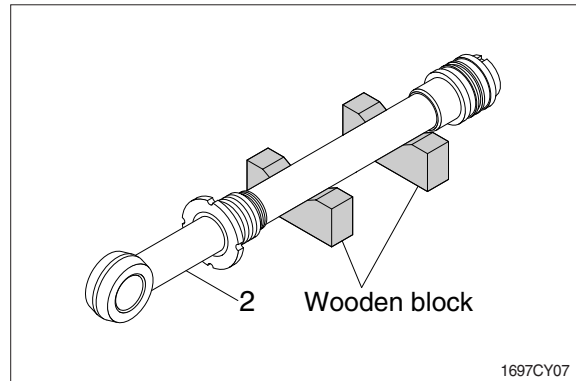

## (2) Remove piston and gland

- ① Remove set screw (17).
- ② Remove piston assembly (12), back up ring (16), O-ring (15) and cushion ring (19).

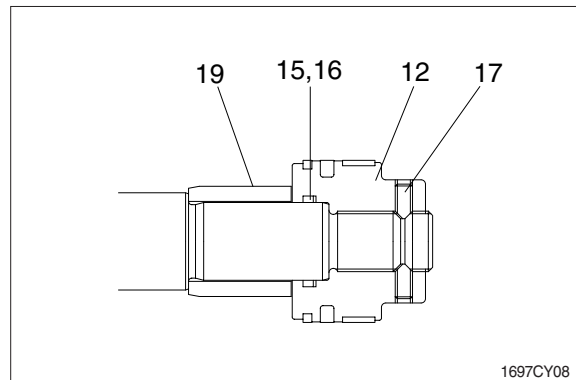

- ④ Remove the gland assembly from rod assembly (2).
  - ※ If it is too heavy to move, move it by striking the flanged part of gland with a plastic hammer.
  - ※ Pull it straight with gland assembly lifted with a crane.
- Exercise care so as not to damage the lip of packing (7, 8, 9, 10, 11) by the threads of rod assembly (2).

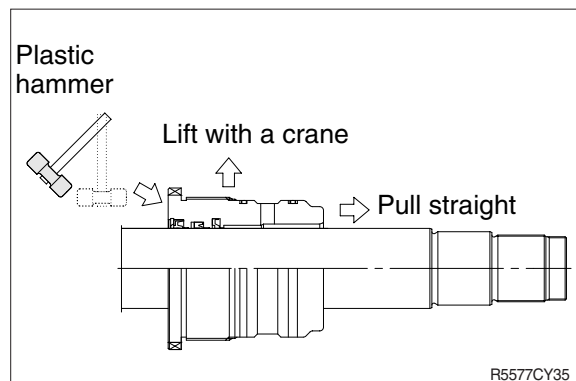

### (3) Disassemble the piston assembly

- ① Remove wear ring (14).
  - ② Remove dust ring (22) and piston seal (13).
- ※ Exercise care in this operation not to damage the grooves.

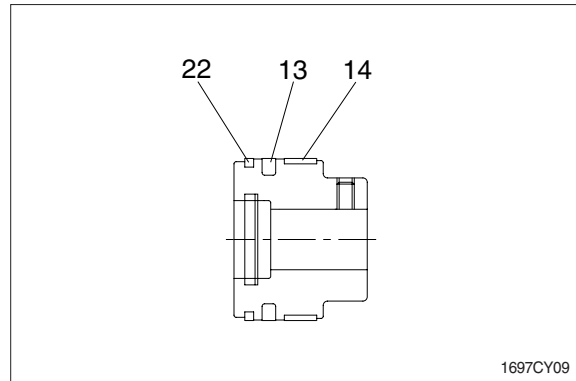

### (4) Disassemble gland assembly

- ① Remove back-up ring (10) and O-ring (9).
  - ② Remove retaining ring (5), dust wiper (4).
  - ③ Remove back up ring (8), rod seal (7).
  - ④ Remove the dry bushing (6).
- ※ Exercise care in this operation not to damage the grooves.
- ※ Do not remove seal and ring, if does not damaged.

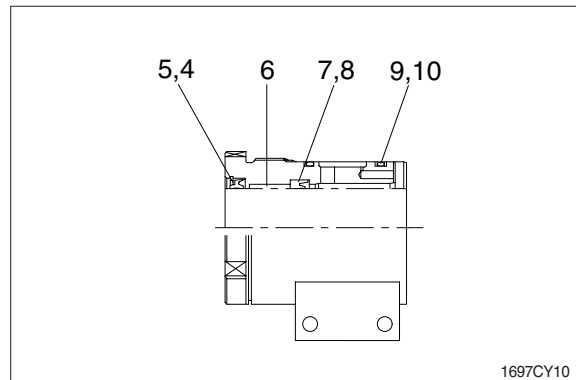

#### 4) ASSEMBLY

##### (1) Assemble cylinder head assembly

- ※ Check for scratches or rough surfaces if found smooth with an oil stone.
- ① Coat the inner face of gland (3) with hydraulic oil.

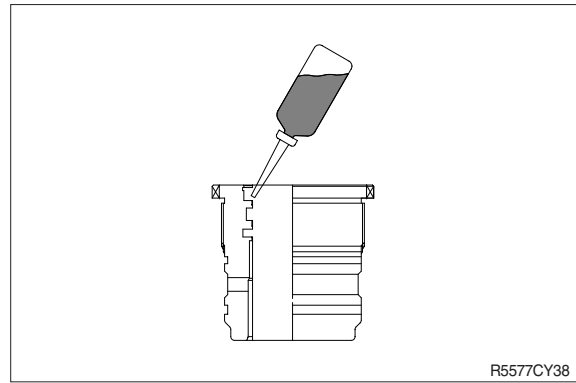

- ② Coat dust wiper (4) with grease and fit dust wiper (4) to the bottom of the hole of dust seal.  
At this time, press a pad metal to the metal ring of dust seal.
- ③ Fit retain ring (5) to the stop face.

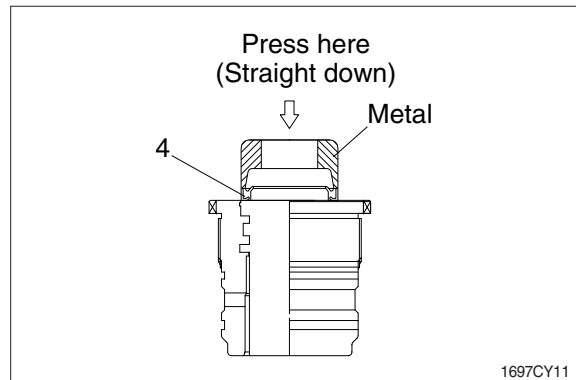

- ④ Fit back up ring (8), rod seal (7) to corresponding grooves, in that order.
  - ※ Coat each packing with hydraulic oil before fitting it.
  - ※ Insert the backup ring until one side of it is inserted into groove.

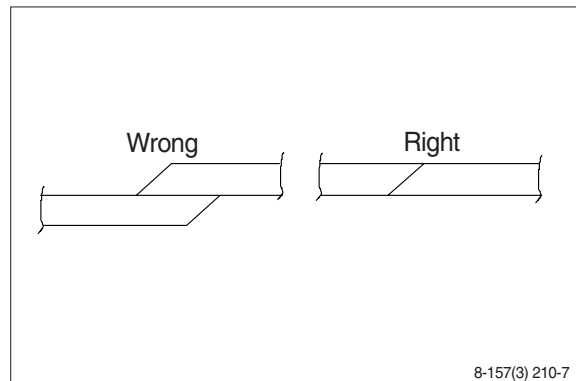

- ※ Rod seal (7) has its own fitting direction. Therefore, confirm it before fitting them.
- ※ Fitting rod seal (7) upside down may damage its lip. Therefore check the correct direction that is shown in fig.

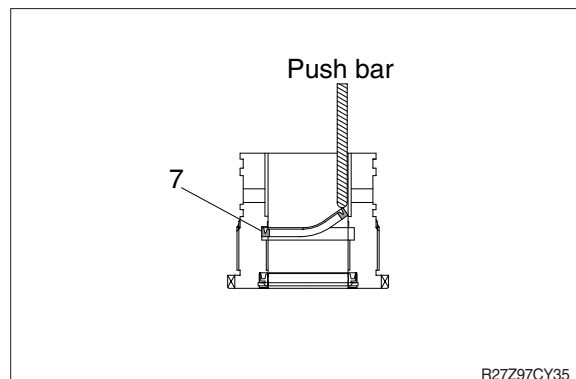

- ⑤ Fit back up ring (10) to gland (3).
- ※ Put the backup ring in the warm water of 30~50°C .
- ⑥ Fit O-ring (9) to gland (3).

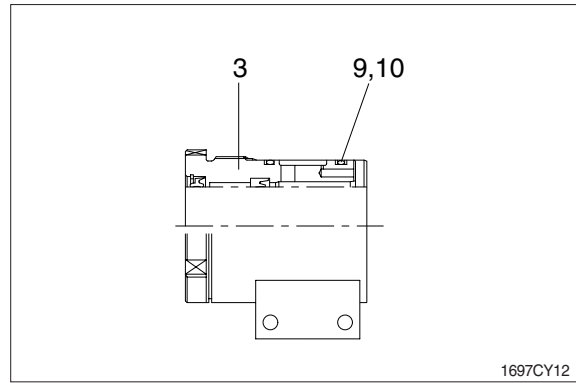

## (2) Assemble piston assembly

- ※ Check for scratches or rough surfaces.  
If found smooth with an oil stone.
- ① Coat the outer face of piston (12) with hydraulic oil.

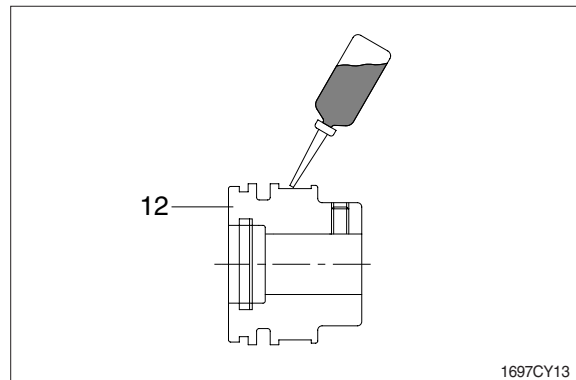

- ② Fit piston seal (13) to piston.
- ※ Put the piston seal in the warm water of 60~100°C for more than 5 minutes.
- ※ After assembling the piston seal, press its outer diameter to fit in.

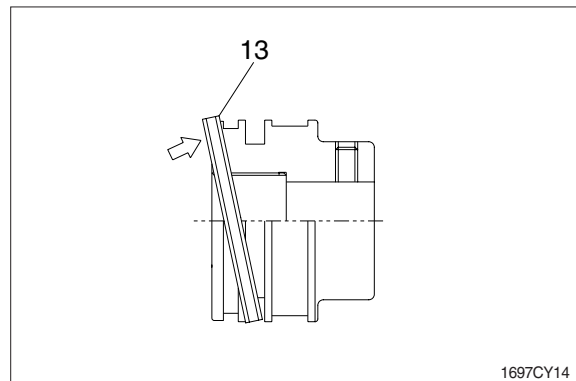

- ③ Fit wear ring (14) and dust ring (22) to piston (12).

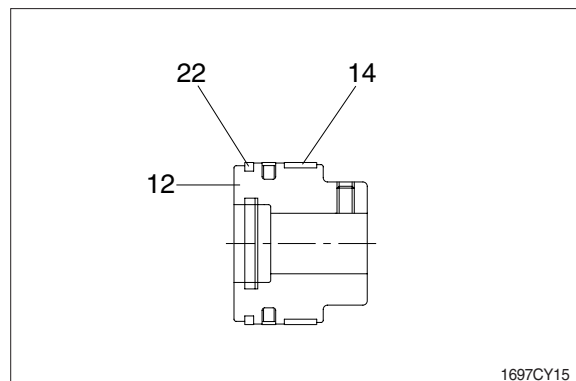

### (3) Install piston and cylinder head

- ① Fix the rod assembly to the work bench.
- ② Apply hydraulic oil to the outer surface of rod assembly (2), the inner surface of piston and gland.
- ③ Insert gland assembly to rod assembly.

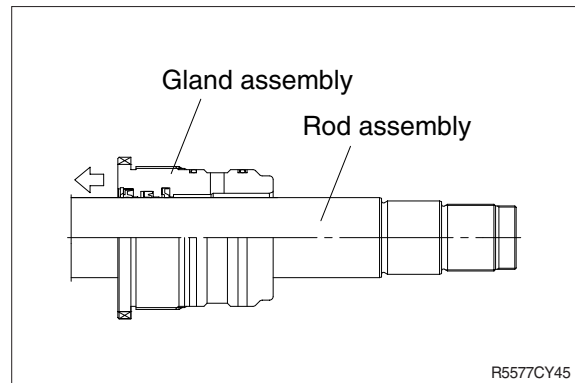

- ④ Insert cushion ring (19) to rod assembly.  
※ Note that cushion ring (19) has a direction in which it should be fitted.

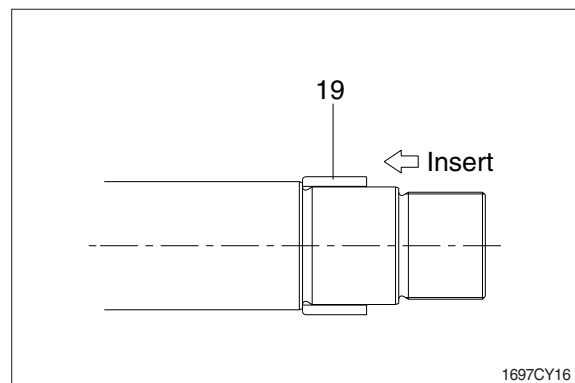

- ⑤ Fit piston assembly to rod assembly.

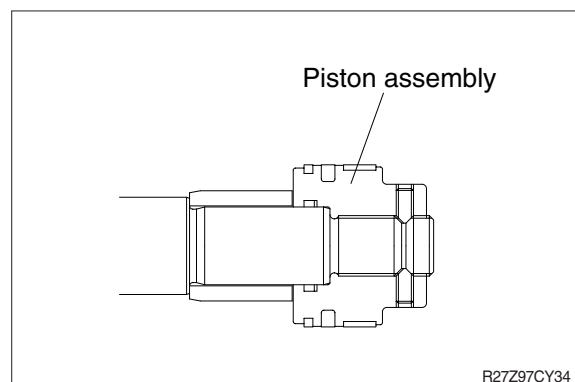

- ⑥ Fit set screw (17).  
· Tightening torque :  
 $2 \pm 0.2 \text{ kgf} \cdot \text{m}$  ( $14.5 \pm 1.45 \text{ lbf} \cdot \text{ft}$ )

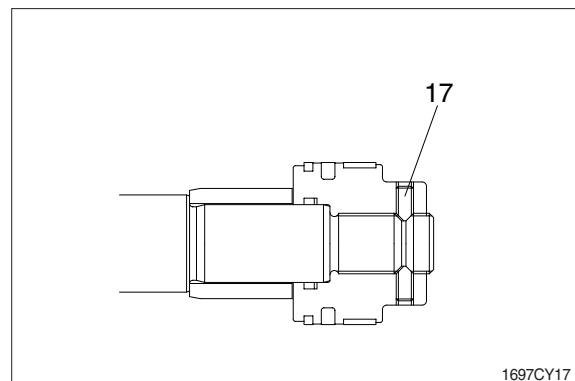

### (3) Overall assemble

- ① Place a V-block on a rigid work bench.  
Mount the tube assembly (1) on it and fix the assembly by passing a bar through the clevis pin hole to lock the assembly.
- ② Insert the rod assembly in to the tube assembly, while lifting and moving the rod assembly (2) with a crane.
  - ※ Be careful not to damage piston seal (13) by thread of tube assembly (1).
- ③ Match the bolt holes in the cylinder head flange to the tapped holes in the tube assembly and tighten socket bolts to a specified torque.
  - ※ Refer to the table of tightening torque.

