

# GROUP 4 SINGLE OPERATION

## 1. BOOM UP OPERATION

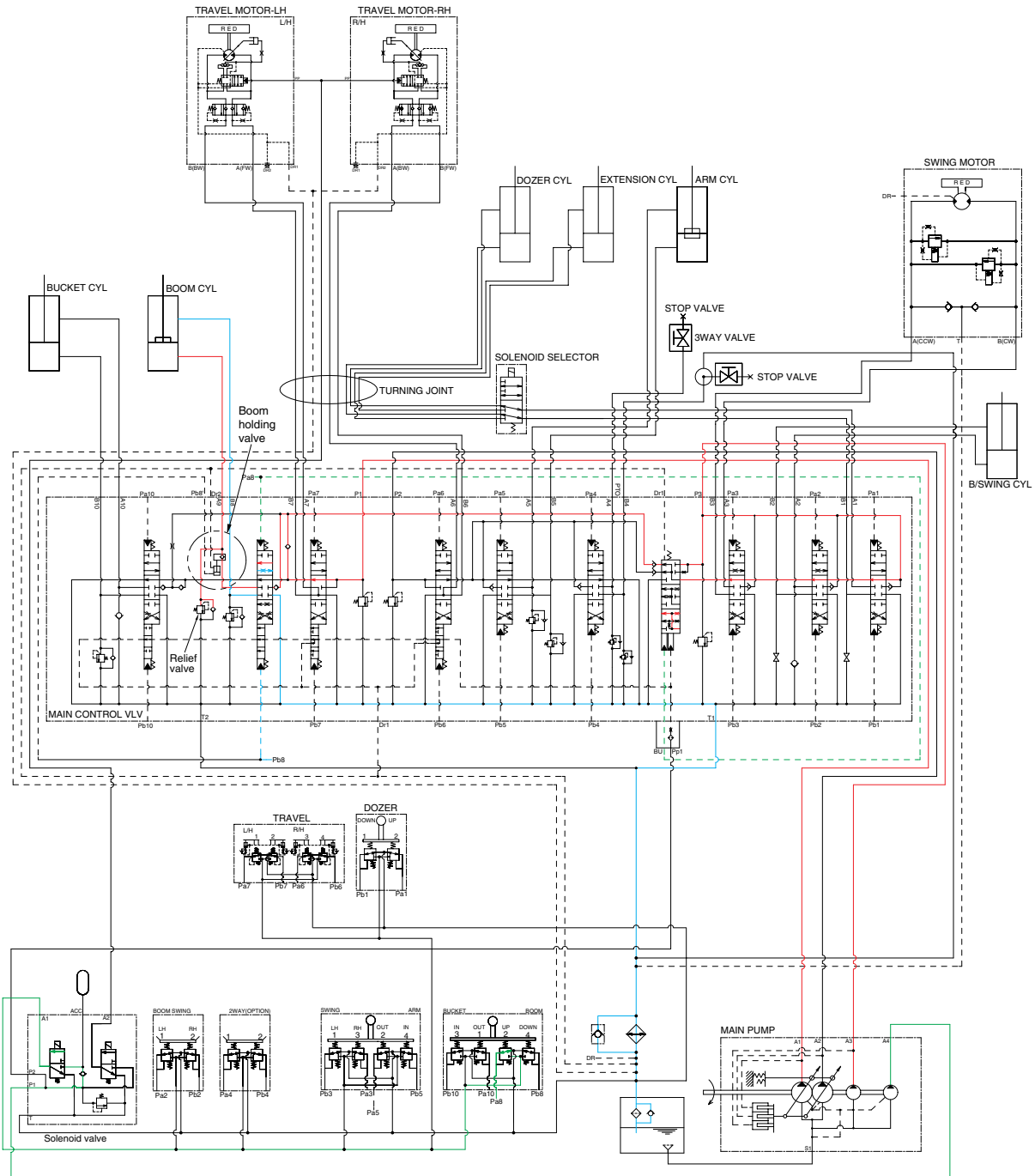

1693HC10

When the right control lever is pulled back, the boom spools in the main control valve are moved to the up position by the pilot oil pressure from the remote control valve.

The oil from the A1 and A3 pump flows into the main control valve and then goes to the large chamber of boom cylinders. At the same time, the oil from the small chamber of boom cylinders returns to the hydraulic oil tank through the boom spool in the main control valve. When this happens, the boom goes up. The excessive pressure in the boom cylinder bottom end circuit is prevented by relief valve. When the boom is up and the control lever is returned to neutral position, the circuit for the holding pressure at the bottom end of the boom cylinder is closed by the boom holding valve. This prevents the hydraulic drift of boom cylinder.

## 2. BOOM DOWN OPERATION

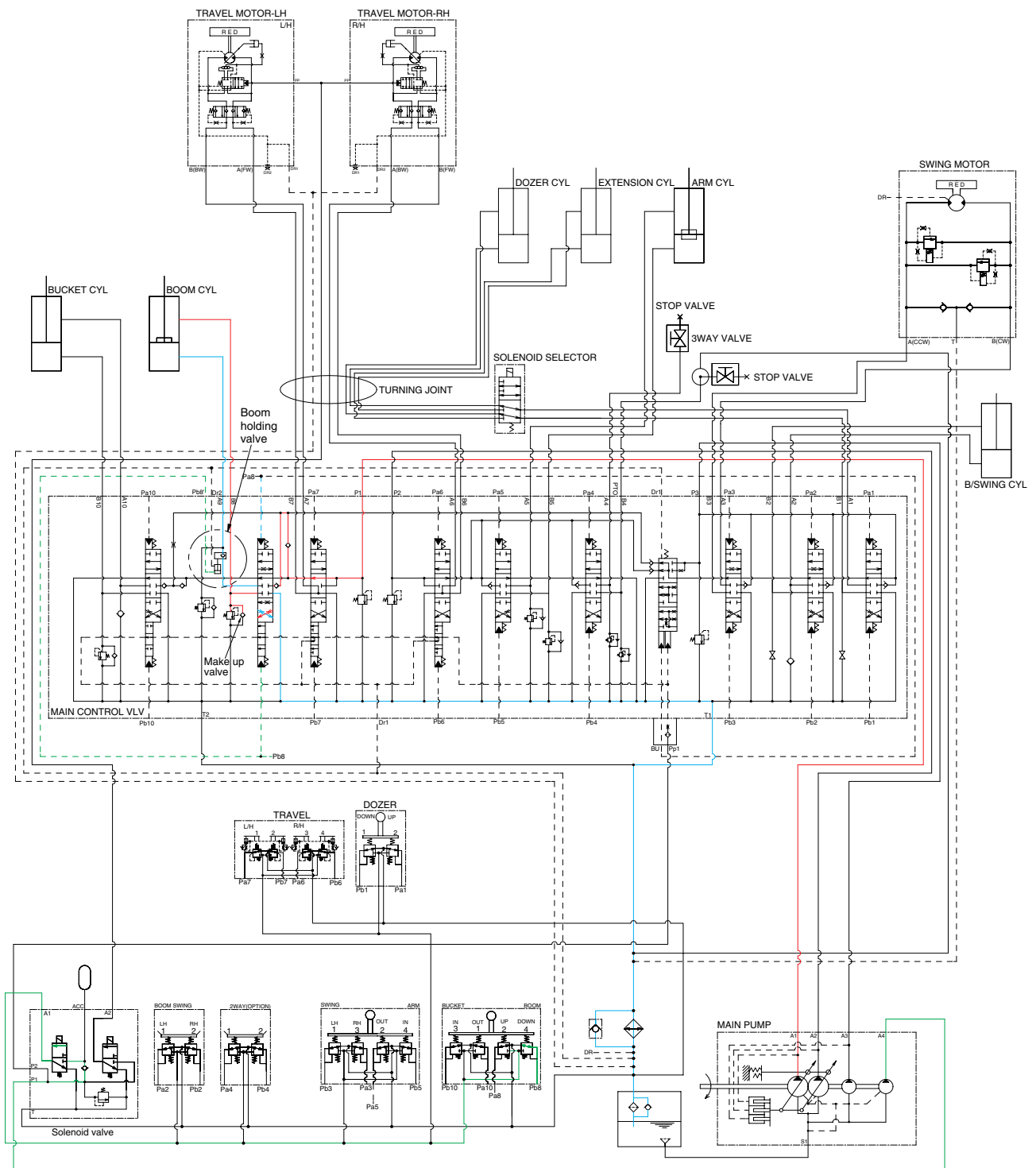

1693HC11

When the right control lever is pushed forward, the boom spools in the main control valve are moved to the down position by the pilot oil pressure from the remote control valve. Since Pb8 port is connected Pb8' port through the piping, boom holding valve is also released.

The oil from the A1 pump flows into the main control valve and then goes to the small chamber of boom cylinders. At the same time, the oil from the large chamber of boom cylinders returns to the hydraulic tank through the boom spool in the main control valve.

The cavitation in the boom cylinder rod end circuit is prevented by the make-up valve.

### 3. ARM ROLL IN OPERATION

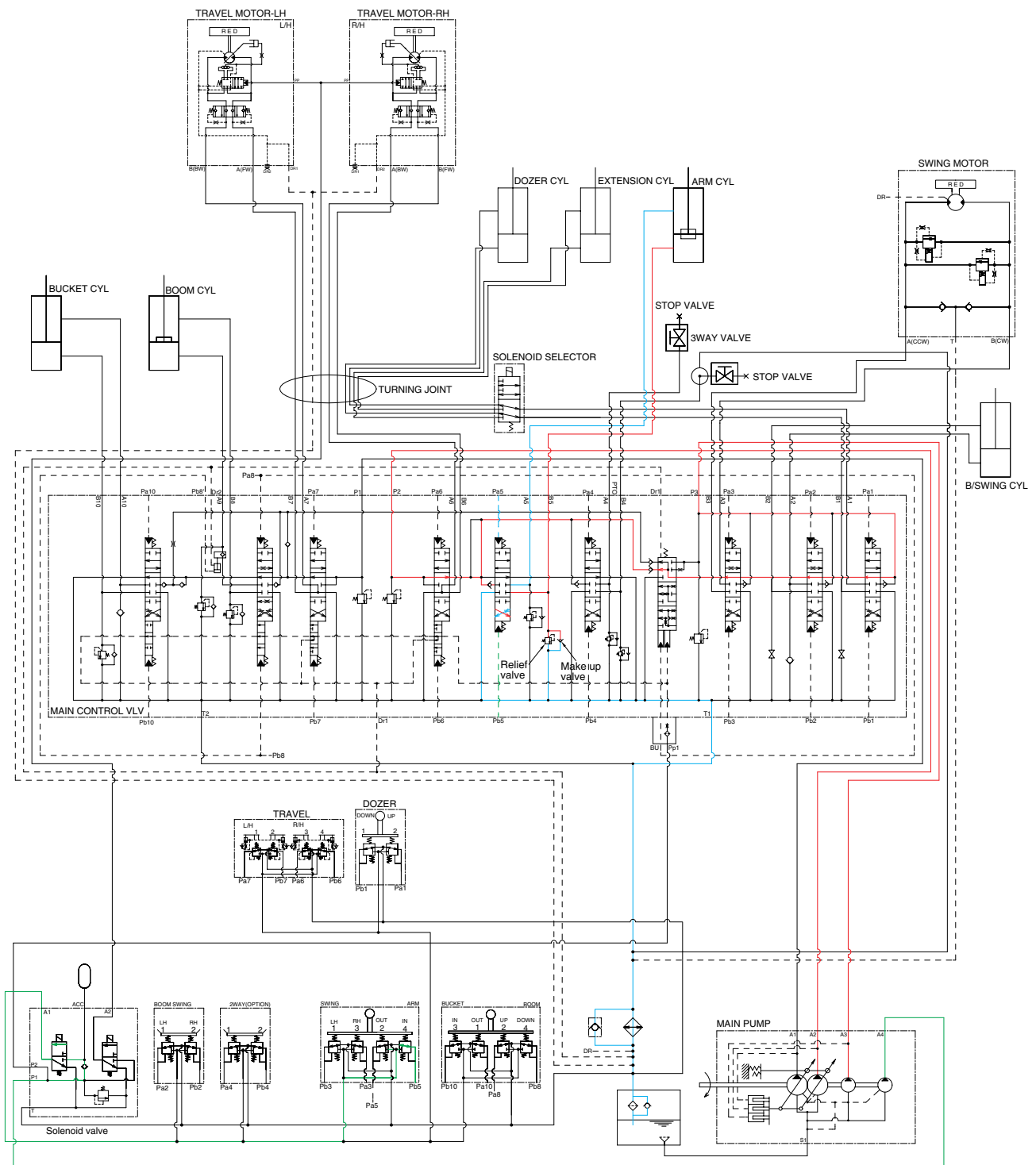

1693HC12

When the left control lever is pulled back, the arm spools in the main control valve are moved to the roll in position by the pilot oil pressure from the remote control valve.

The oil from the A2 and A3 pump flows into the main control valve and then goes to the large chamber of arm cylinder.

At the same time, the oil from small chamber of arm cylinder returns to the hydraulic oil tank through the arm spool in the main control valve. When this happens, the arm rolls in.

The cavitation and excessive pressure in the bottom of the arm cylinder is also prevented by the make-up valve and the relief valve in the main control valve.

## 4. ARM ROLL OUT OPERATION

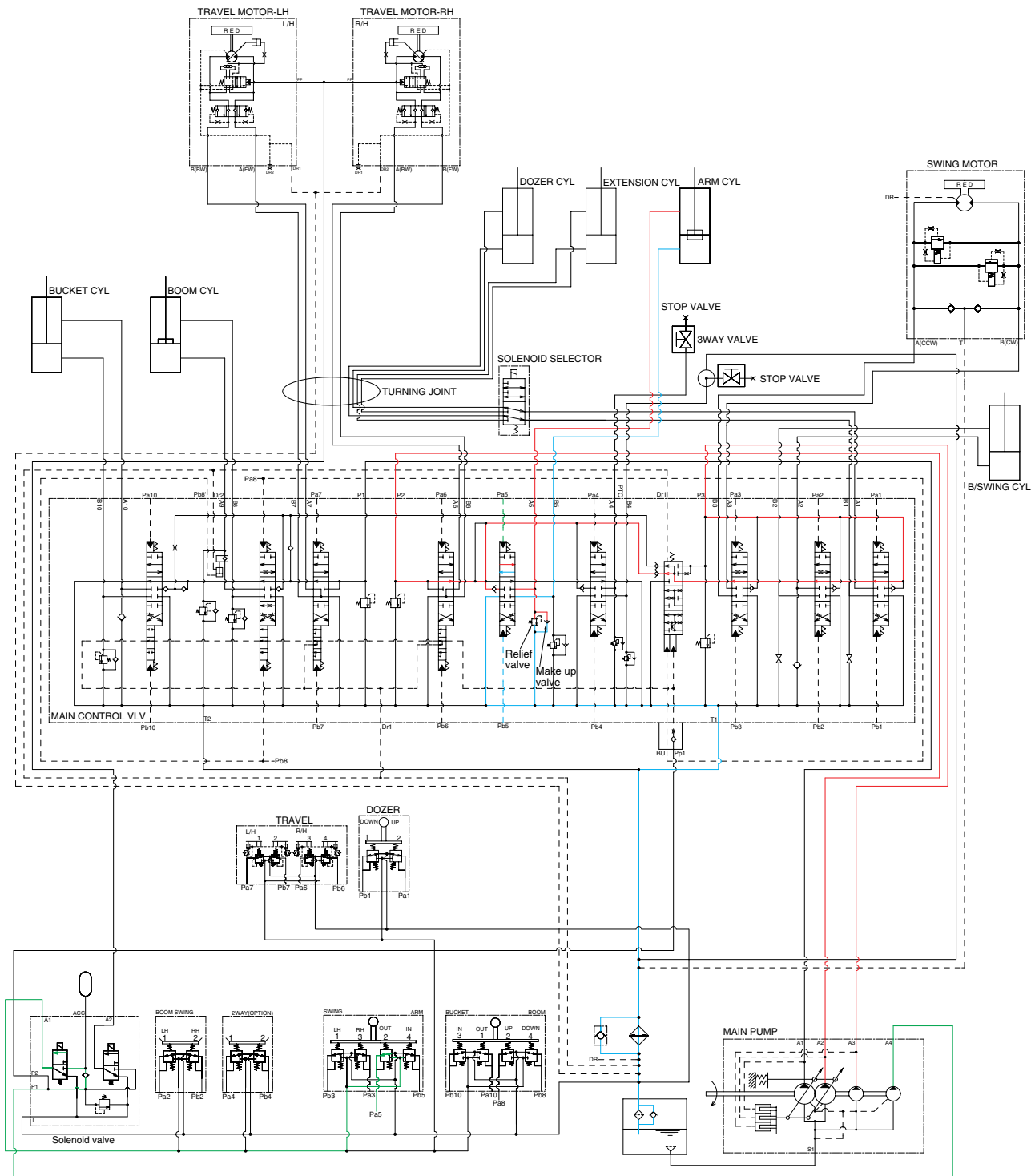

1693HC13

When the left control lever is pushed forward, the arm spool in the main control valve are moved to the roll out position by the pilot oil pressure from the remote control valve.

The oil from the A2 and A3 pump flows into the main control valve and then goes to the small chamber of arm cylinder.

At the same time, the oil from the large chamber of arm cylinder returns to the hydraulic oil tank through the arm spool in the main control valve. When this happens, the arm rolls out.

The cavitation and excessive pressure in the rod down of the arm cylinder is also prevented by the make-up valve and relief valve in the main control valve.

## 5. BUCKET ROLL IN OPERATION

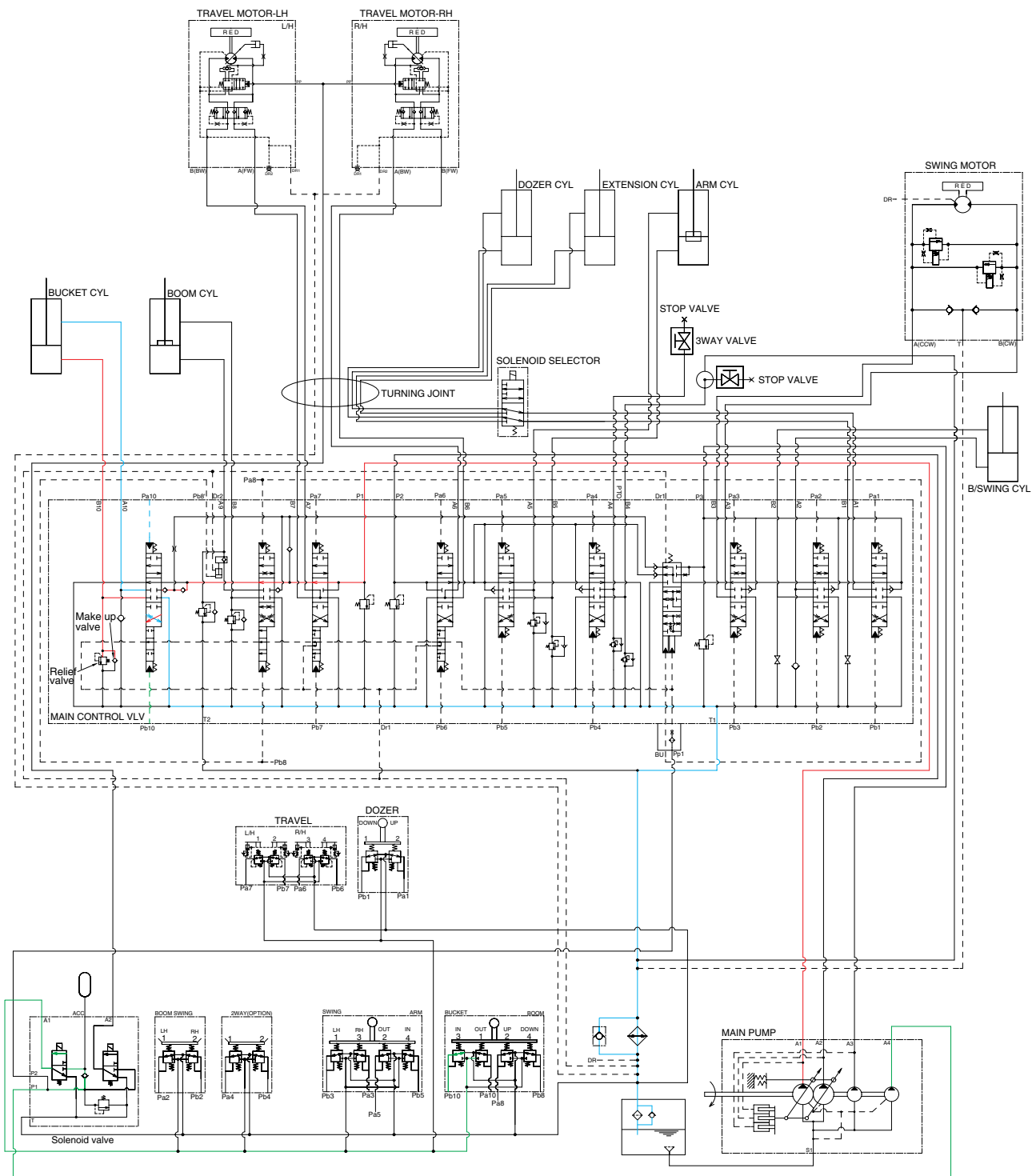

1693HC14

When the right control lever is pulled left, the bucket spool in the main control valve is moved to the roll in position by the pilot oil pressure from the remote control valve.

The oil from the A1 pump flows into the main control valve and then goes to the large chamber of bucket cylinder.

At the same time, the oil from the small chamber of bucket cylinder returns to the hydraulic oil tank through the boom spool in the main control valve. When this happens, the bucket rolls in.

The cavitation and excessive pressure in the bottom of the bucket cylinder is also prevented by the make-up valve and relief valve in the main control valve.

## 6. BUCKET ROLL OUT OPERATION

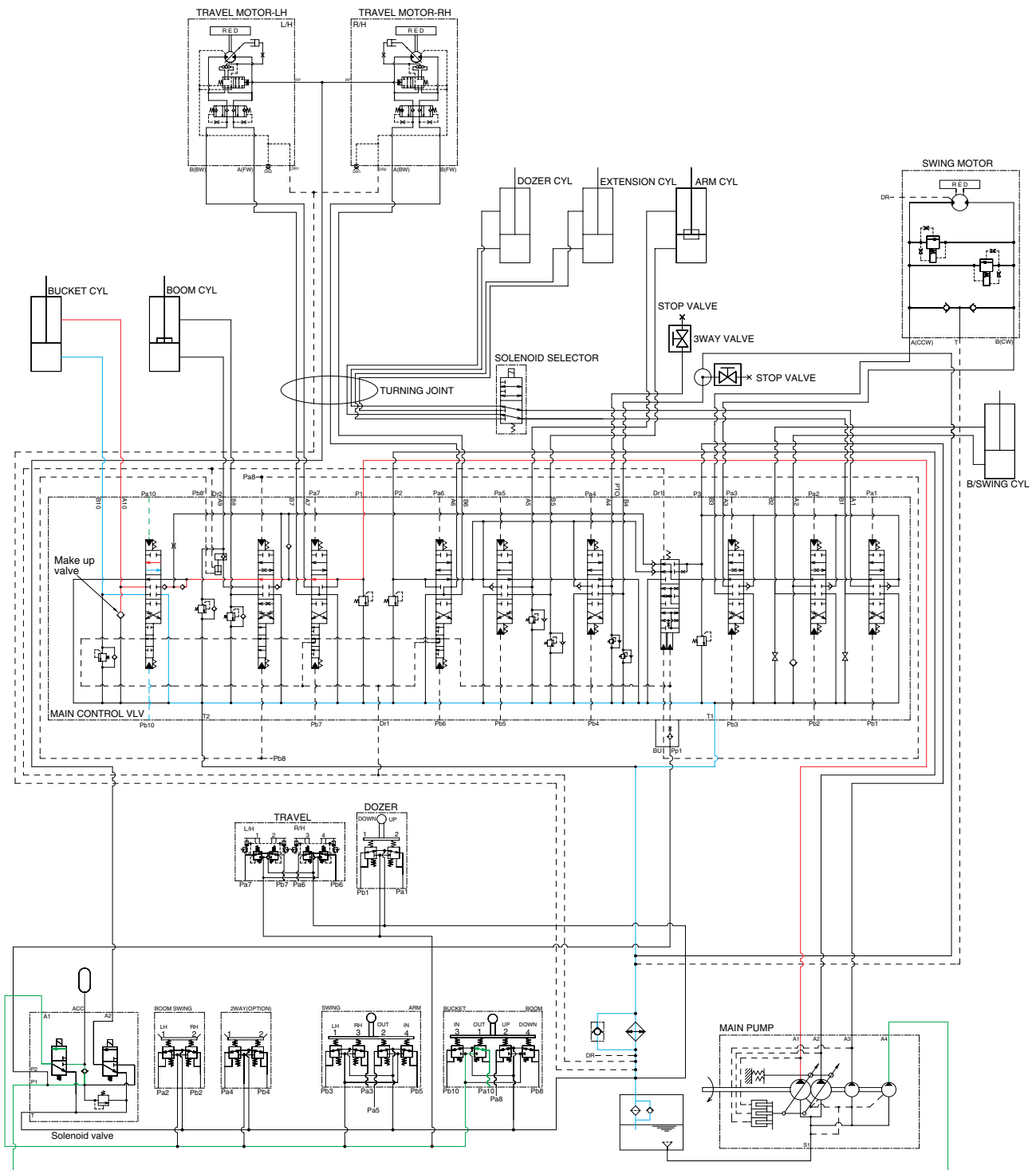

1693HC15

When the right control lever is pushed right, the bucket spool in the main control valve is moved to the roll out position by the pilot oil pressure from the remote control valve.

The oil from the A1 pump flows into the main control valve and then goes to the small chamber of bucket cylinder.

At the same time, the oil from the large chamber of bucket cylinder returns to the hydraulic oil tank through the bucket spool in the main control valve. When this happens, the bucket rolls out.

The cavitation which will happen to the rod of the bucket cylinder is also prevented by the make-up valve in the main control valve.

## 7. SWING OPERATION

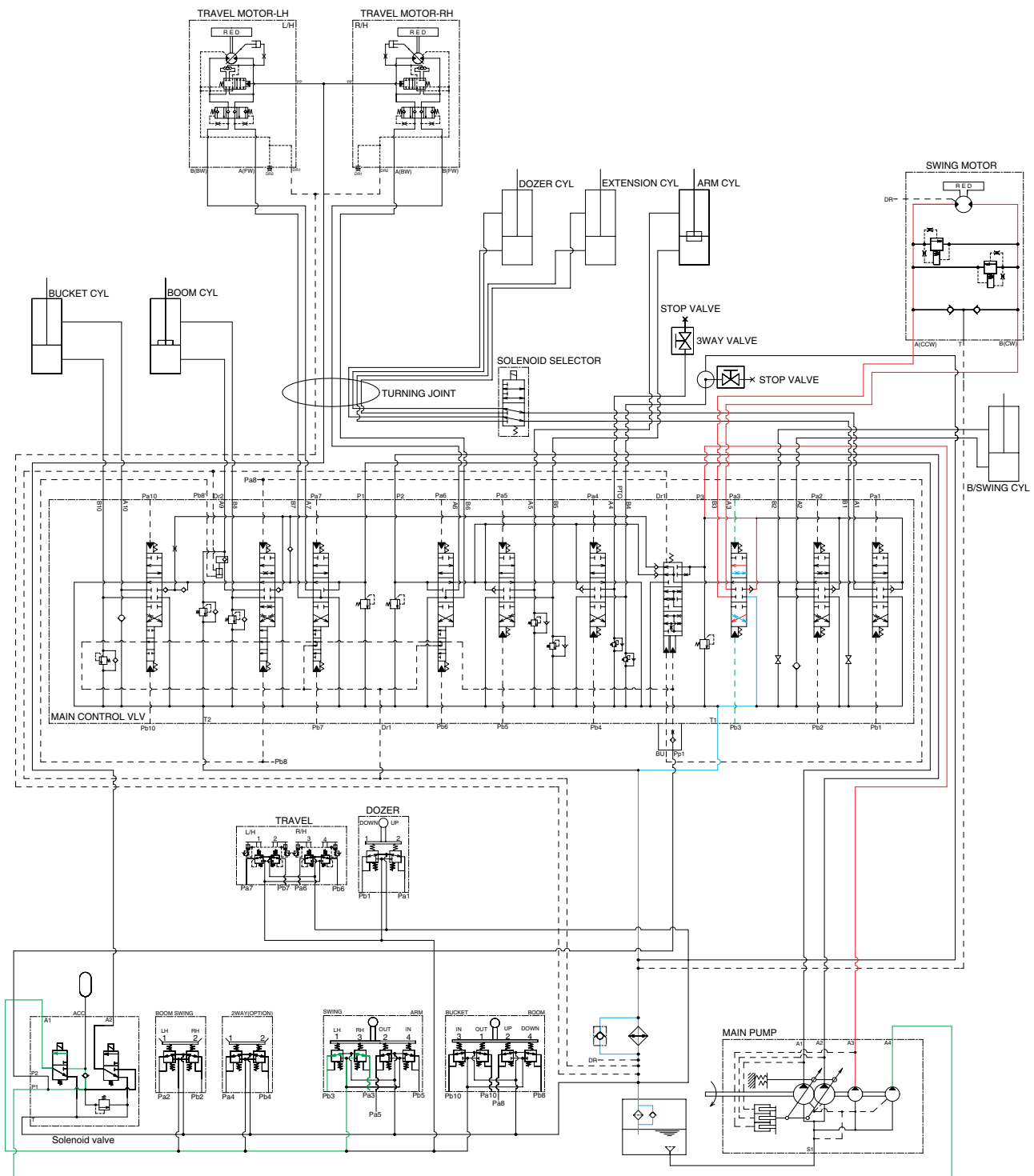

1693HC16

When the left control lever is pushed left or right, the swing spool in the main control valve is moved to the left or right swing position by the pilot oil pressure from the remote control valve. The oil from the A3 pump flows into the main control valve and then goes to the swing motor. At the same time, the return oil from the swing motor returns to the hydraulic oil tank through the swing spool in the main control valve. When this happens, the superstructure swings to the left or right. The make up valve and the overload relief valve are provided in the swing motors. The cavitation which will happen to the swing motor is also prevented by the make up valve in the swing motor itself.

## SWING CIRCUIT OPERATION

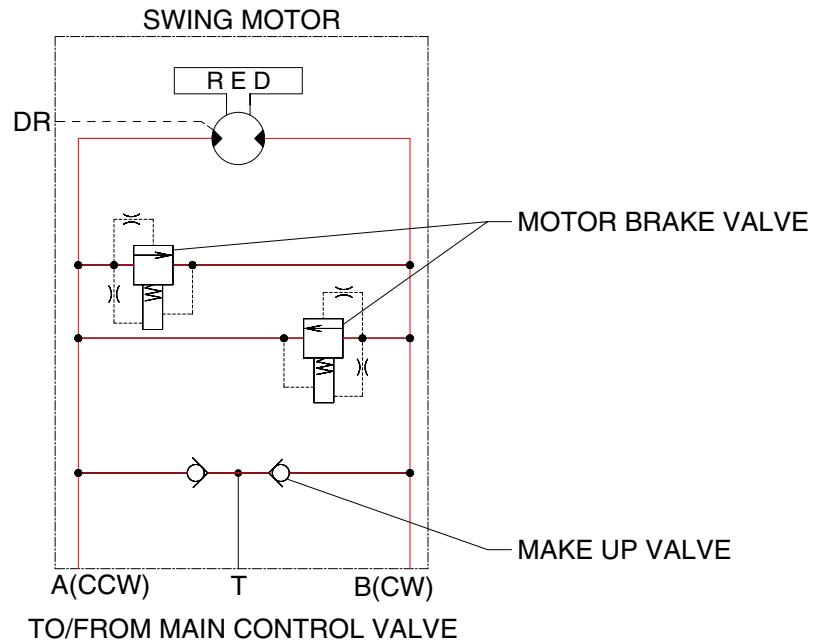

1693HC20

### 1) MOTOR BRAKE VALVE

Motor brake valve for the swing motor limits to cushion the starting and stopping pressure of swing operation.

### 2) MAKE UP VALVE

The make up valves prevent cavitation by supplying return oil to the vacuum side of the motor.

## 8. TRAVEL FORWARD AND REVERSE OPERATION

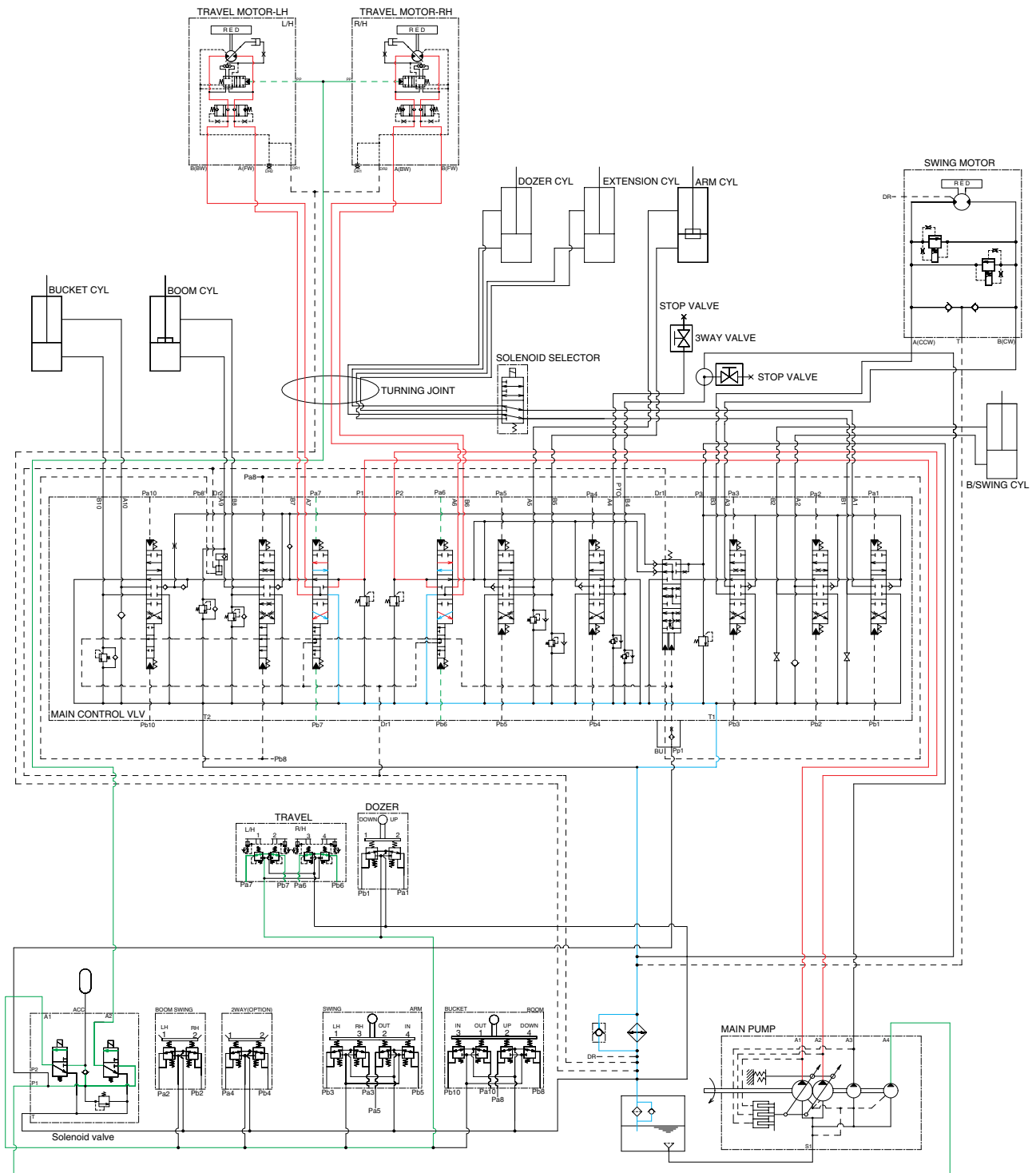

1693HC17

When the travel levers are pushed forward or reverse position, the travel spools in the main control valve are moved to the forward or reverse travel position by pilot pressure oil. The oil from the both pumps flows into the main control valve and then goes to the both travel motors through the turning joint. The return oil from both travel motors returns to the hydraulic oil tank through the turning joint and the travel spools in the main control valve. When this happens, the machine moves to the forward or reverse.

## TRAVEL CIRCUIT OPERATION

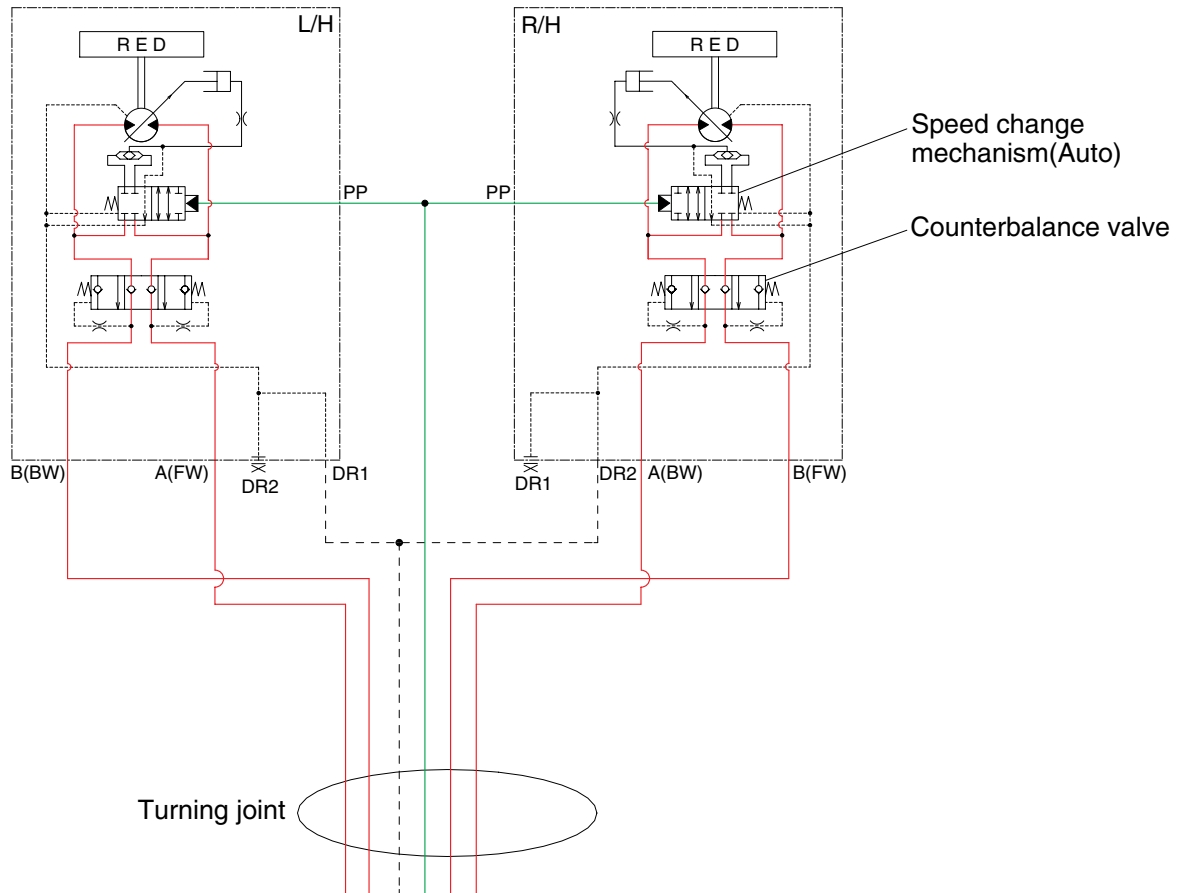

1693HC21

Valves are provided on travel motors to offer the following functions.

### 1) COUNTERBALANCE VALVE

When stopping the motor of slope descending, this valve to prevent the motor over run.

### 2) SPEED CHANGE MECHANISM (auto)

Auto two speed control mechanism consists of two spools and spring. This valve automatically changes motor displacement in portion to motor pressure.

## 9. DOZER UP OPERATION

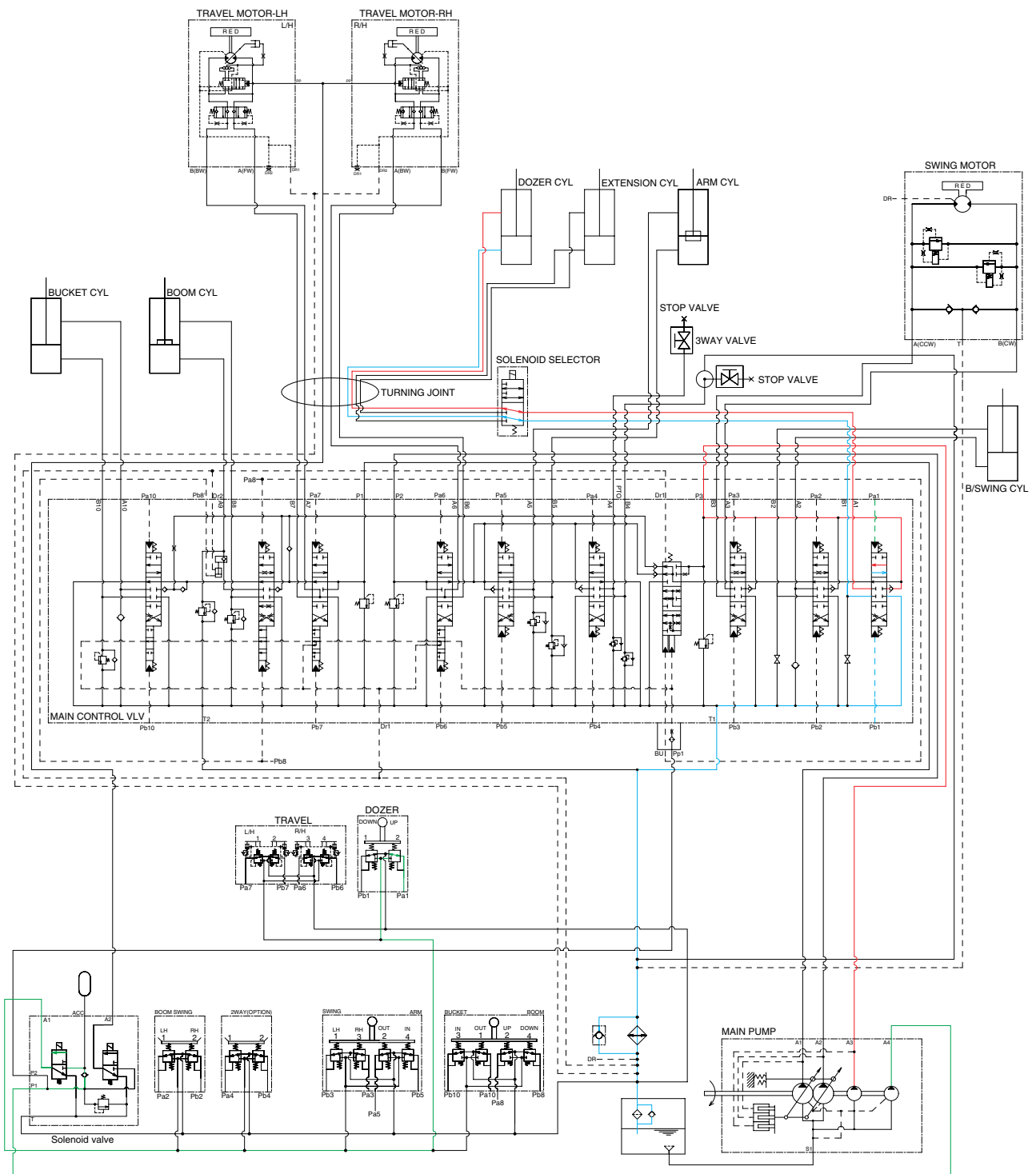

1693HC18

When the dozer control lever is pulled back, the dozer spool in the main control valve is moved to the dozer up position by the pilot oil pressure from the remote control valve.

The oil from the A3 pump flows into the main control valve and then goes to the small chamber of dozer cylinders.

At the same time, the oil from the large chamber of dozer cylinders returns to the hydraulic oil tank through the dozer spool in the main control valve. When this happens, the dozer goes up.

## 10. DOZER DOWN OPERATION

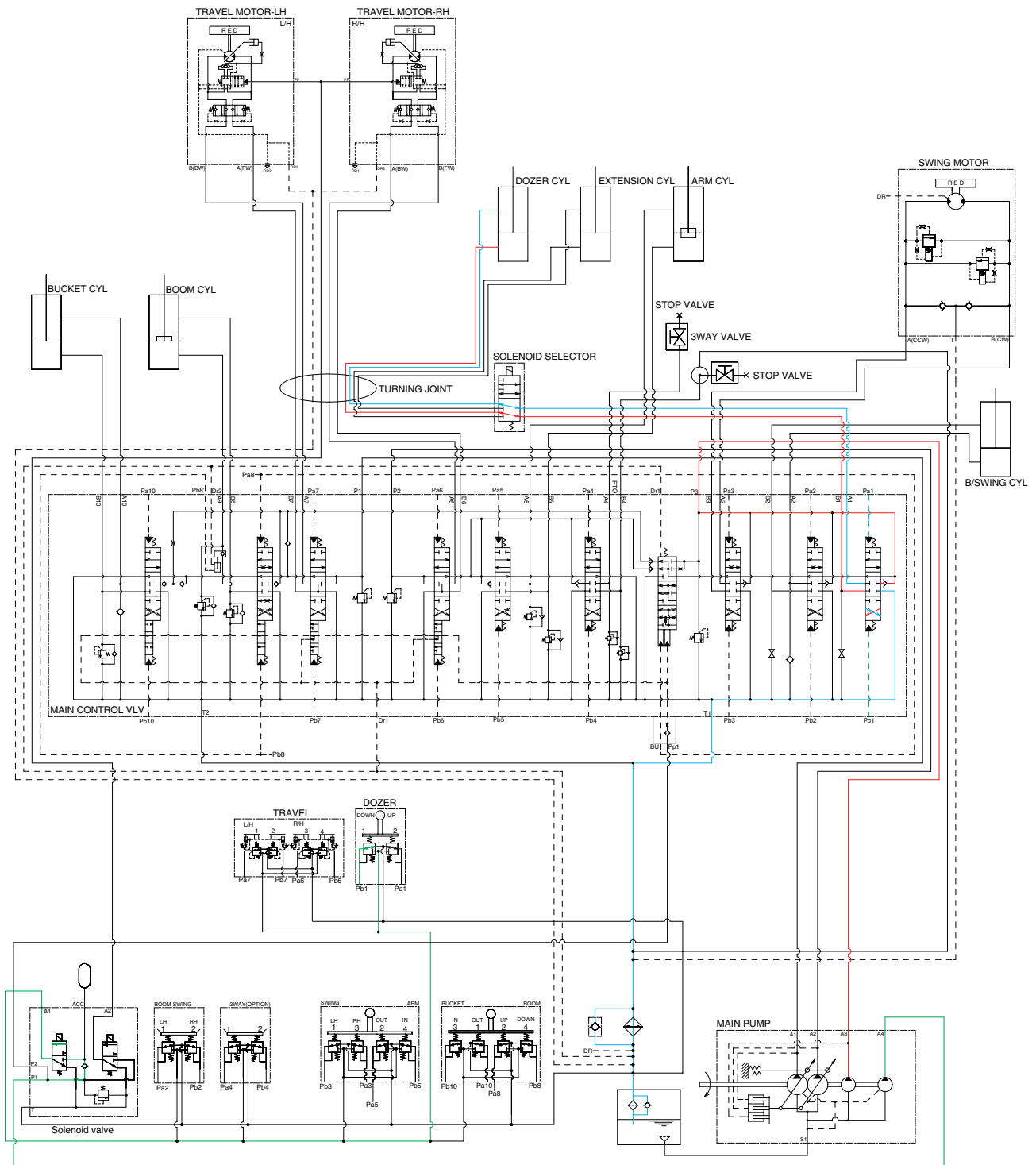

1693HC19

When the dozer control lever is pushed forward, the dozer spool in the main control valve is moved to the dozer down position by the pilot oil pressure from the remote control valve.

The oil from the A3 pump flows into the main control valve and then goes to the large chamber of dozer cylinders.

At the same time, the oil from the small chamber of dozer cylinders returns to the hydraulic oil tank through the dozer spool in the main control valve. When this happens, the dozer blade is down.