

GROUP 2 ENGINE SYSTEM

1. ENGINE AND ACCESSORIES MOUNTING

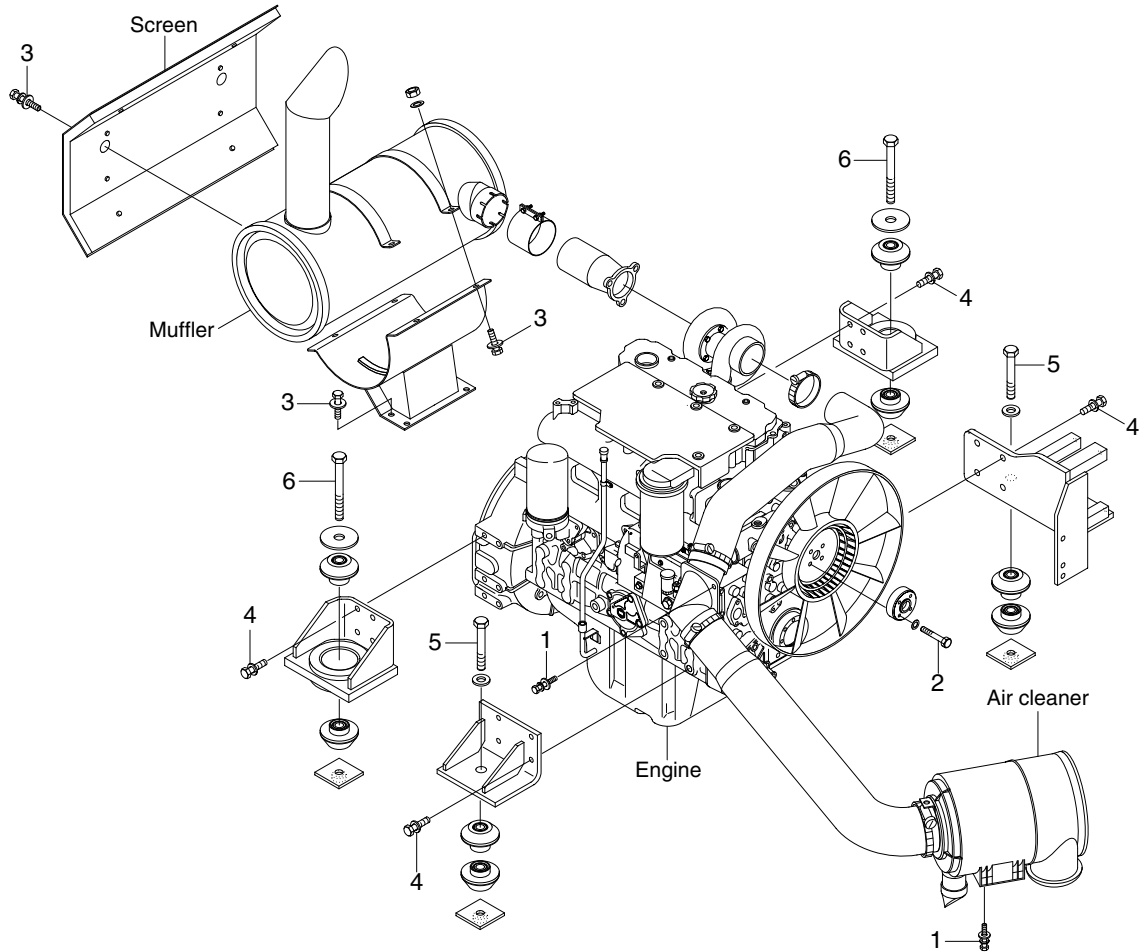

140Z99CM01

· Tightening torque

| Item | Size | kgf · m | lbf · ft |
|------|----------|---------|-----------|
| 1 | M 8×1.25 | 2.5±0.5 | 18.1±3.6 |
| 2 | M10×1.5 | 4.4±0.9 | 31.8±6.5 |
| 3 | M10×1.5 | 6.9±1.4 | 49.9±10.1 |

| Item | Size | kgf · m | lbf · ft |
|------|----------|----------|----------|
| 4 | M12×1.75 | 10.0±1.0 | 72.3±7.2 |
| 5 | M16×2.0 | 30±3.5 | 217±25.3 |
| 6 | M20×2.5 | 55±3.5 | 398±25.3 |

2. COOLING SYSTEM AND FUEL TANK MOUNTING

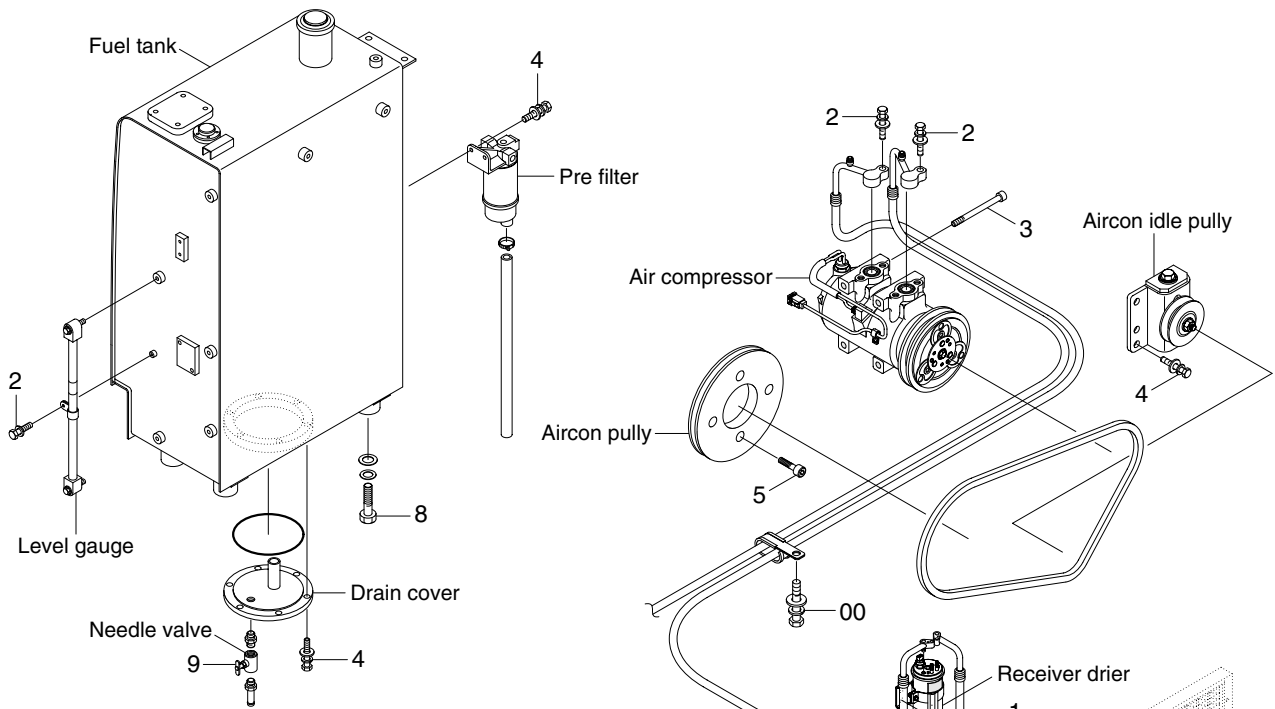

COOLING SYSTEM

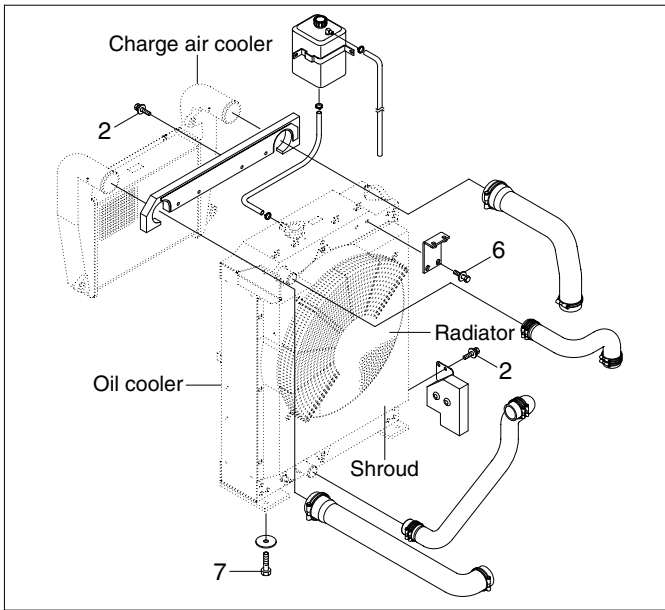

140Z99CM02

• Tightening torque

| Item | Size | kgf · m | lbf · ft |
|------|----------|----------|-----------|
| 1 | M 6×1.0 | 1.05±0.2 | 7.6±1.45 |
| 2 | M 8×1.25 | 2.5±0.5 | 18.1±3.6 |
| 3 | M 8×1.25 | 3.43±0.7 | 24.8±5.1 |
| 4 | M10×1.5 | 6.9±1.4 | 49.9±10.1 |
| 5 | M10×1.5 | 8.3±1.7 | 60.0±12.3 |

| Item | Size | kgf · m | lbf · ft |
|------|----------|----------|-----------|
| 6 | M12×1.75 | 12.8±3.0 | 92.6±21.7 |
| 7 | M16×2.0 | 29.7±4.5 | 215±32.5 |
| 8 | M20×2.5 | 46±5.1 | 333±36.9 |
| 9 | - | 2.3±0.6 | 16.6±4.3 |