

GROUP 6 TRAVEL DEVICE

1. REMOVAL AND INSTALL

1) REMOVAL

- (1) Swing the work equipment 90° and lower it completely to the ground.
- (2) Operate the control levers and pedals several times to release the remaining pressure in the hydraulic piping.
- (3) Loosen the breather slowly to release the pressure inside the hydraulic tank.
- ▲ **Escaping fluid under pressure can penetrate the skin causing serious injury.**
 - ※ When pipes and hoses are disconnected, the oil inside the piping will flow out, so catch it in oil pan.
- (4) Remove the track shoe assembly.
For details, see **removal of track shoe assembly**.
- (5) Remove the cover.
- (6) Remove the hose.
 - ※ Fit blind plugs to the disconnected hoses.
- (7) Remove the bolts and the sprocket.
- (8) Sling travel device assembly (1).
- (9) Remove the mounting bolts (2), then remove the travel device assembly.
 - Weight : 240 kg (530 lb)

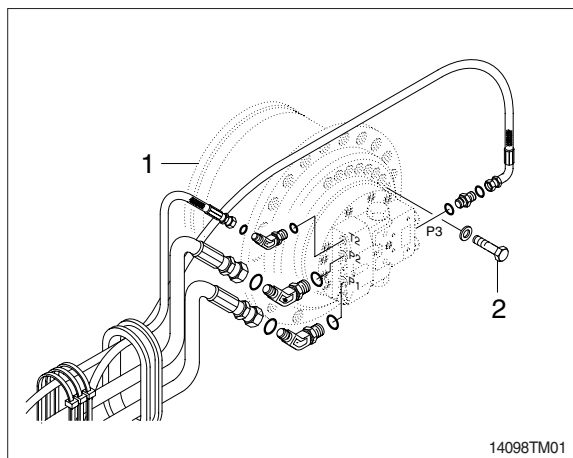

2) INSTALL

- (1) Carry out installation in the reverse order to removal.
- (2) Bleed the air from the travel motor.
 - ① Remove the air vent plug.
 - ② Pour in hydraulic oil until it overflows from the port.
 - ③ Tighten plug lightly.
 - ④ Start the engine, run at low idling, and check oil come out from plug.
 - ⑤ Tighten plug fully.
- (3) Confirm the hydraulic oil level and check the hydraulic oil leak or not.

2. TRAVEL MOTOR

1) STRUCTURE

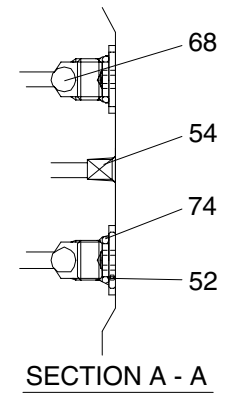
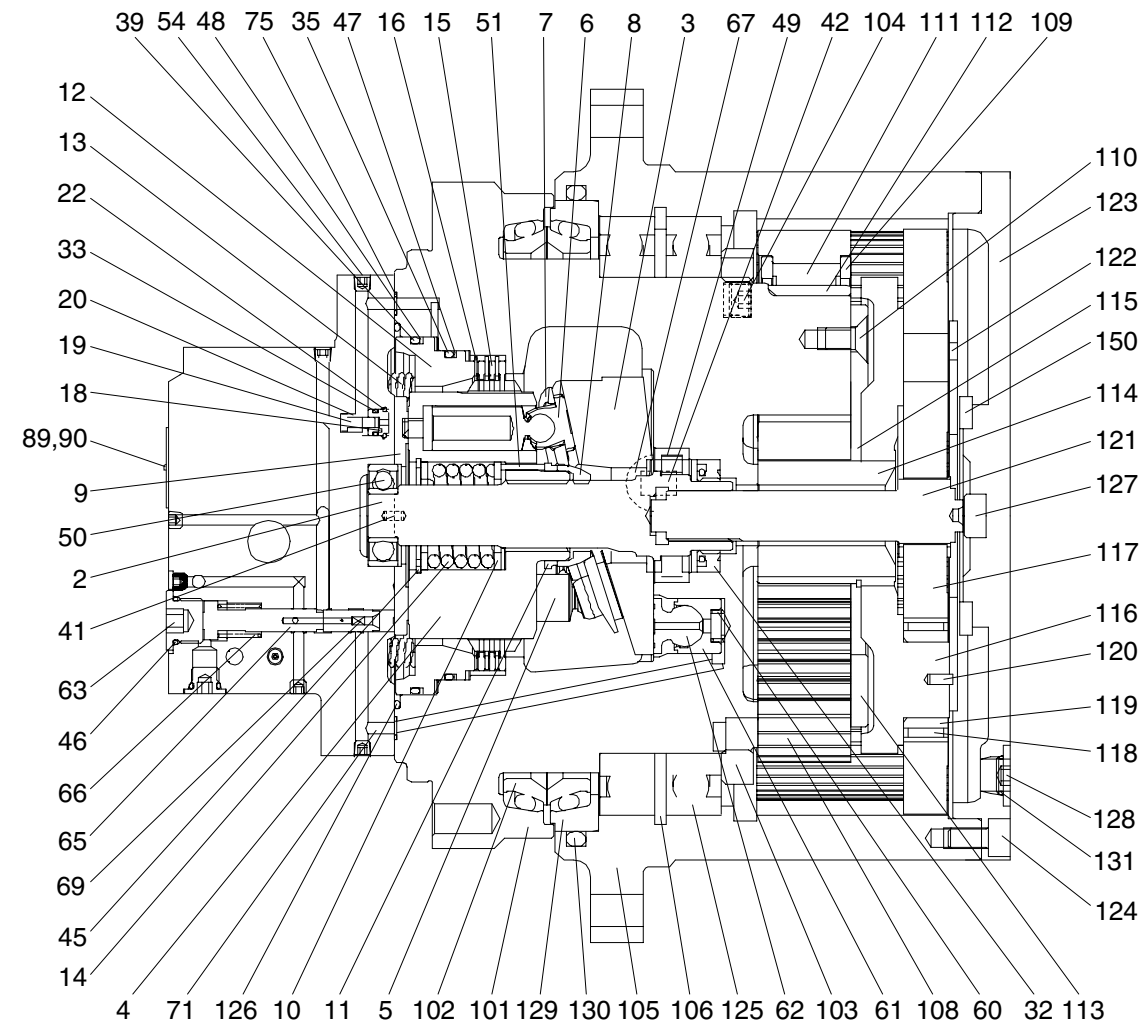
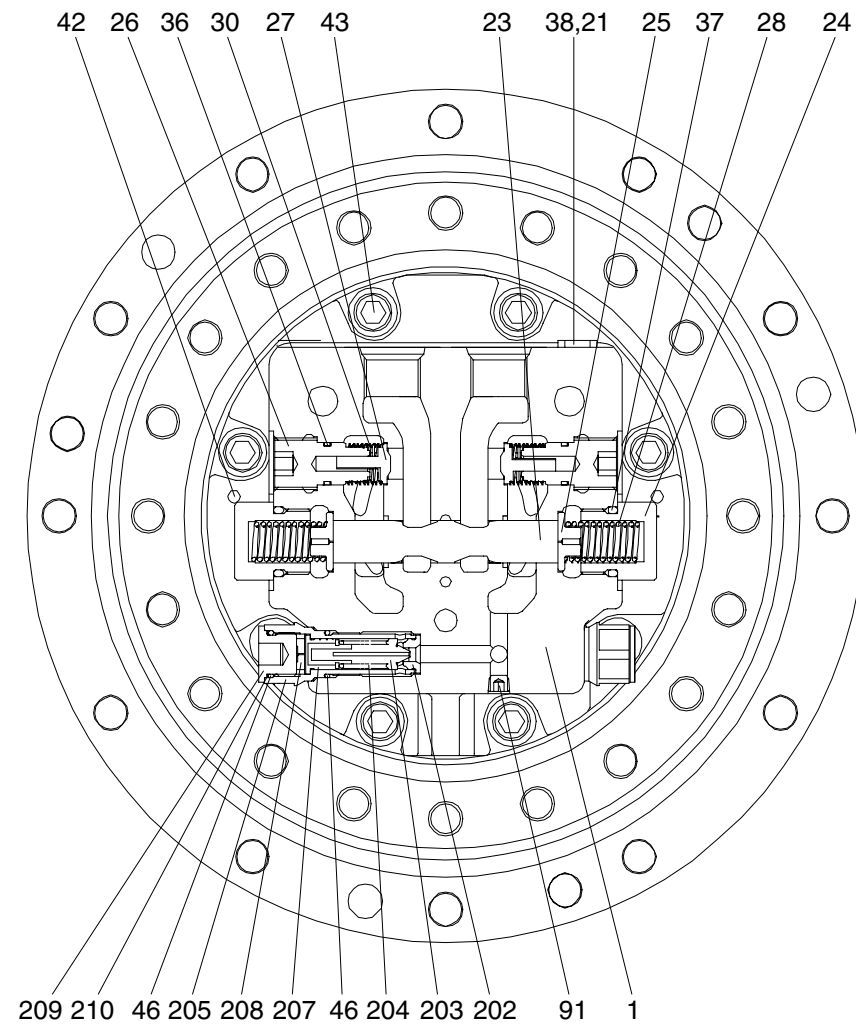

1	Rear flange	19	Valve	39	O-ring	65	2 Speed spool	108	Planetary gear	125	Angular bearing
2	Shaft	20	Spring	41	Parallel pin	66	2 Speed spring	109	Thrust washer	126	O-ring
3	Swash plate	21	Plug	42	Parallel pin	67	Pivot	110	Screw	127	Thrust washer
4	Cylinder block	22	Ring	43	Socket bolt	68	Steel ball	111	Needle bearing	128	Plug
5	Piston	23	Main spool	45	Snap ring	69	Set screw	112	Collar	129	Seal ring
6	Shoe	24	Main plug	46	O-ring	71	Orifice	113	Thrust plate	130	O-ring
7	Retainer plate	25	Retainer spring	47	Back up-ring	74	O-ring	114	Sun gear	131	O-ring
8	Thrust ball	26	Check plug	48	Back up-ring	75	O-ring	115	Snap ring	150	Thrust plate
9	Timing plate	27	Check valve	49	Roller bearing	89	Name plate	116	Holder	205	Body
10	Washer	28	Main spring	50	Ball bearing	90	Set screw	117	Planetary gear	206	Shim
11	Washer-collar	30	Check spring	51	Roller	91	Plug	118	Needle bearing	207	Piston
12	Piston-parking	32	Oil seal	52	Plug	101	Spindle	119	Inner race	208	Rod
13	Spring	33	O-ring	54	Plug	102	Floating seal	120	Spring pin	209	Plug
14	Spring	35	O-ring	60	Spring	103	Nut ring	121	Drive gear	210	Back up-ring
15	Friction plate	36	O-ring	61	Piston	104	Plug	122	Thrust plate		
16	Mating plate	37	O-ring	62	Shoe	105	Hub	123	Cover		
18	Seat valve	38	O-ring	63	Plug	106	Snap ring	124	Socket bolt		

14092TM03

2) TOOLS

(1) Standard tools

No.	Name	Description/Size	Qty
1	Hexagon wrench (JIS B 4650)	6 (M8) (PT1/4), 8 (M10)	each 1
		10 (M12) (PF1/2)	each 1
		4 (M6)	1
2	Socket wrench	-	1
3	Torque wrench	Nominal 30 kgf · m dial type	1
		Nominal 90 kgf · m dial type	1
4	Adapter for torque wrench	Socket 26, 27, 36	each 1
		Bar 4, 5, 6, 8, 10	each 1
5	Extension bar (JIS B 4637)	150 mm	1
6	Hammer (JIS B 4613)	12	1
7	Plastic hammer	L=300	1
8	(-) driver	150 mm	1
9	Snap ring plier	For shaft, For hole	1
10	Hanger	Weight : over 300 kgf	1
		Eye bolt (M16)	2
		Eye bolt (M10)	2
		Eye bolt (PF 1/2)	2
		Wire	1
11	Press	Press capacity above 200 kgf	1
12	Compressed air	3~5 kgf/cm ² , nozzle	1
13	Vessel	General vessel : W450 × D300 × H120	2
14	Heating vessel	Heating capacity : over 100 °C	1
		Volume : 500 × 500 × 500	
15	Depth micro-meter	Measuring range : 0.04 ~ 0.3 mm	1
16	Air hammer	BRH-8 (compressed air 5~6 kgf/cm ²)	1
17	Sealant	Silicone rubber (780-RTV)	1

(2) Special tools

① Inversion working bench

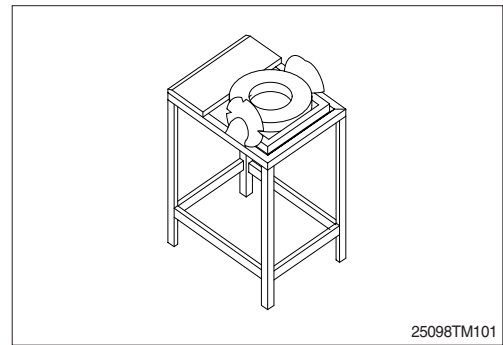

② Pressurize jig (I)

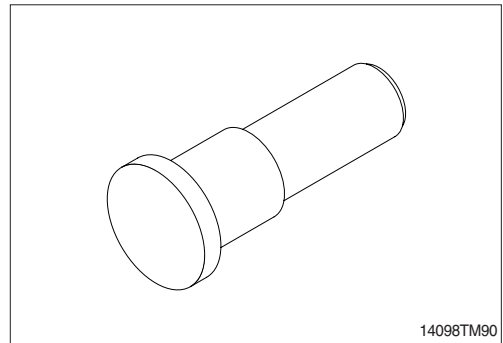

③ Pressurize jig (II)

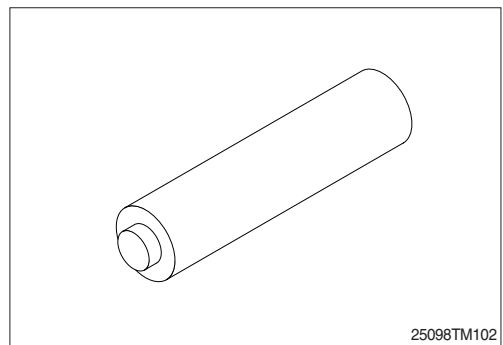

④ Aluminum bar

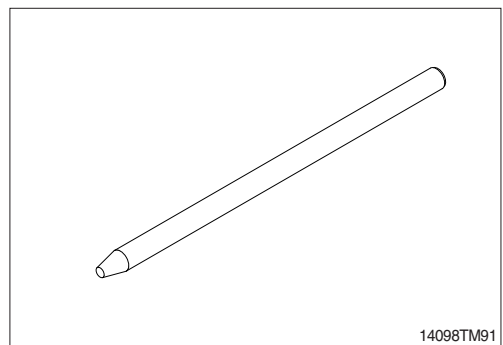

⑤ Steel bar

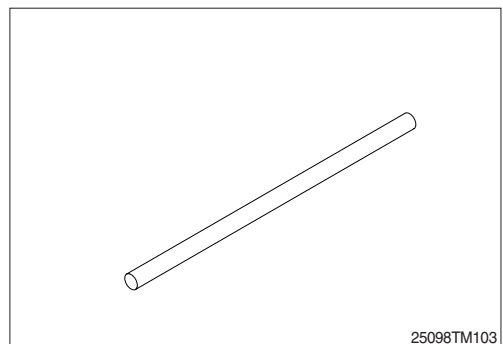

⑥ Sharp punch

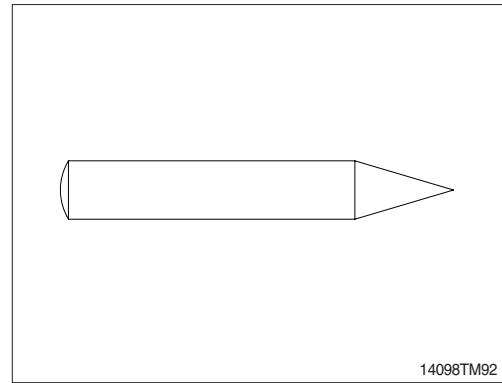

⑦ Draw bar

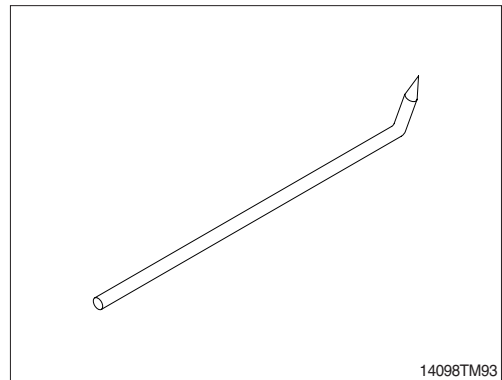

3) TIGHTENING TORQUE

Item No.	Parts name	Size	Qty	Tightening torque	
				kgf · m	lbf · ft
21	Plug	PF 3/8	1	10 ± 2	72.3 ± 14.5
24	Plug	M30 × 1.5	2	36 ± 7.2	260 ± 52.1
26	Plug	M24 × 1.5	2	17 ± 3.4	123 ± 24.6
43	Socket bolt	M10 × 1.5	8	5.9 ± 1.2	42.7 ± 8.7
52	RO plug	PF 1/4	4	3.0 ± 0.5	21.7 ± 3.6
54	Plug	NPTF 1/16	7	1.0 ± 0.25	7.2 ± 1.8
63, 209	Plug	PF 1/2	1	3.0 ± 0.5	21.7 ± 3.6
91	Plug	PT 1/8	4	1.25 ± 0.2	9 ± 1.4
104	Plug	PT 3/8	3	6.0 ± 0.9	43 ± 6.5
110	Screw	M6	4	0.83 ± 0.12	6 ± 0.9
128	Plug	PF 3/8	3	6.0 ± 0.9	43 ± 6.5
124	Socket bolt	M8	12	1.25 ± 0.2	9 ± 1.4
205	Body	M20	1	12 ± 1.5	86.8 ± 10.8
301	Plug	PF 1 1/2	1	26 ± 5.2	188 ± 37.6

3. DISASSEMBLY

3.1 GENERAL PRECAUTIONS

- 1) Spread rubber or vinyl cover on the work bench.
- 2) When disassembling the travel motor, provide a match mark on the mating face of each part.
- 3) Arrange the detached parts to prevent them from being damaged or lost.
- 4) The disassembled seals must be replaced with new ones as a rule even if they are free from damage. For disassembly, therefore, prepare new seals in advance.

3.2 DISASSEMBLY PROCEDURE

- 1) When inspecting or repairing the travel motors, use the disassembling procedures described below.
- 2) Numerals in brackets () following the part name denote the item numbers used in the structure drawing at page 8-68.
- 3) Prior to disassembly, install the travel motor on an inversion working bench.

3.3 DISASSEMBLING ORDER

1) DISASSEMBLING THE REDUCTION GEAR PART

- (1) Remove plugs (128, 3EA) and drain the reduction gear oil.
- (2) Loosen socket bolts (124, 16EA) and remove the cover (123).
 - ※ Remove the cover (123), after hook it, fit the eye bolt in a screw hole for use of the plug (128). If it's impossible, please remove the cover using the rod.
 - ※ You can have difficulty removing it because loctite is spread in the socket bolt (124).
 - ※ Tools
 - Hexagon wrench 6, 8

- (3) Remove thrust plate R (122) and drive gear (121).

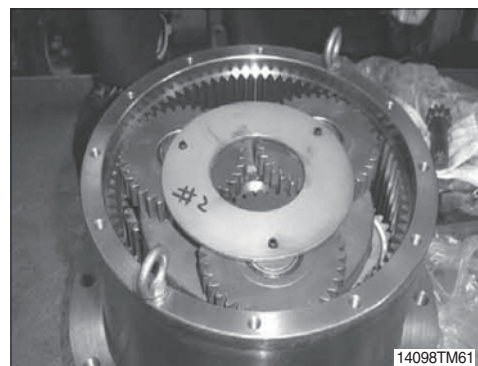
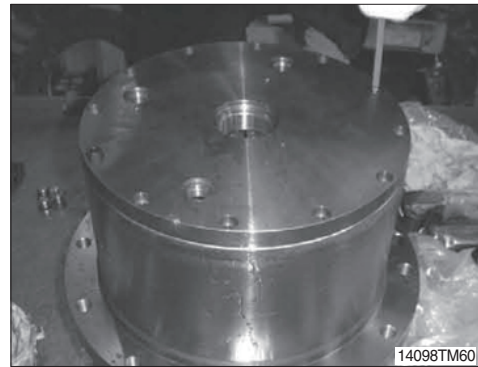

(4) Remove planetary gear R (117), needle bearing, inner race (119) and holder (116) from hub (105).

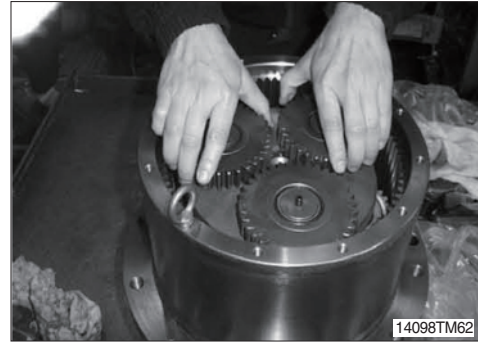

(5) Remove sun gear (114), screw (110) and thrust plate F (113).

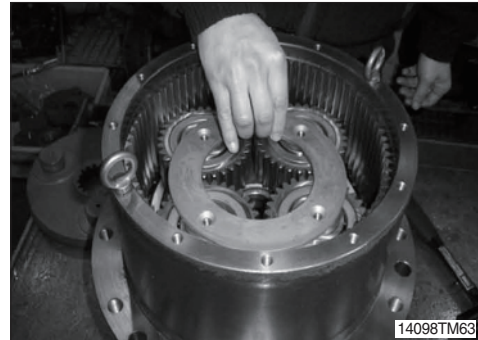

(6) Remove the thrust washer (109), planetary gears F (108), needle bearings (111) and collar (112) from hub (105).

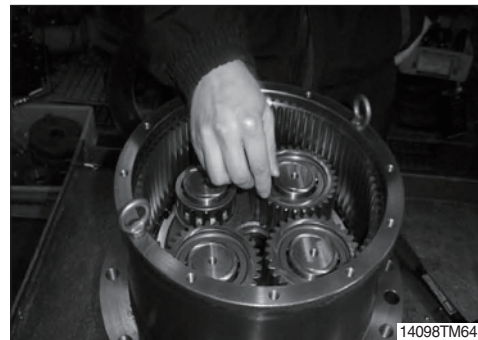

(7) Remove the plugs (104, 3EA).

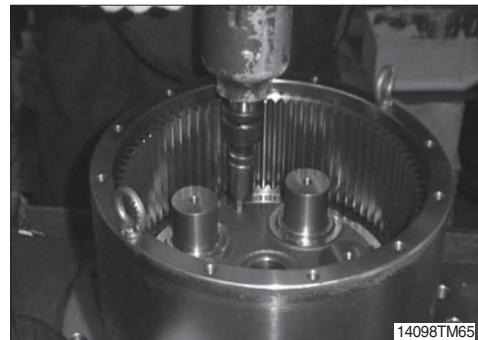

(8) Remove the nut ring (103) from hub (105).



(9) Remove the spindle (101) from the hub (105).

※ Remove it using a crane after eye bolt is assembled at the hub (105).

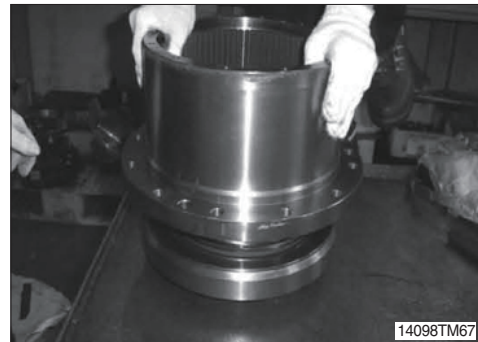

(10) Remove the floating seal (102), seal ring (129), angular bearings (125, 2EA), snap ring (106) and O-ring (130) from the hub (105).

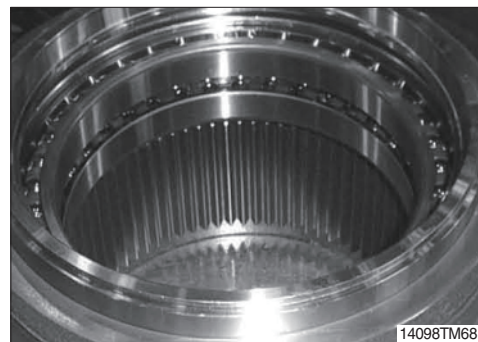

(11) Remove the floating seal (102) from the spindle (101).

※ User can remove easily if using (-) drivers.



(12) Remove the oil seal (32) from spindle (101).

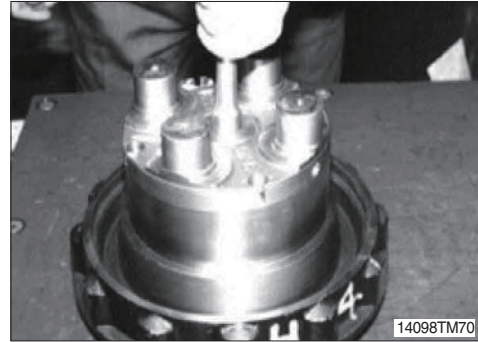

2) DISASSEMBLING THE HYDRAULIC MOTOR PART

(1) Remove the relief valve (70, 2EA) from rear flange (1).

※ Tools

- Hexagon socket
- Torque wrench

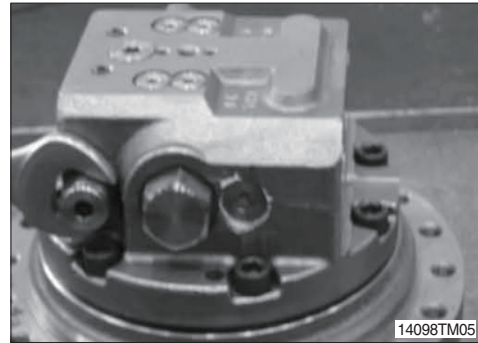

(2) Remove hexagon socket head bolts (43, 8EA) from the rear flange (1).

※ Tools

- Hexagon wrench 8

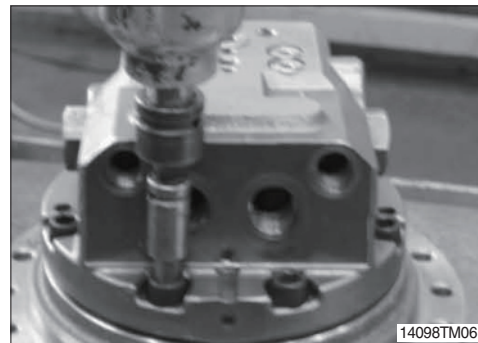

(3) Remove the rear flange (1) from the spindle (101).

(4) Remove the springs (13, 10EA) from the rear flange [1].

※ Remove the rear flange (1) carefully after taken using hands. Be careful not to detach the timing plate (9) and the spring (13) if twisted or beaten by constraint.

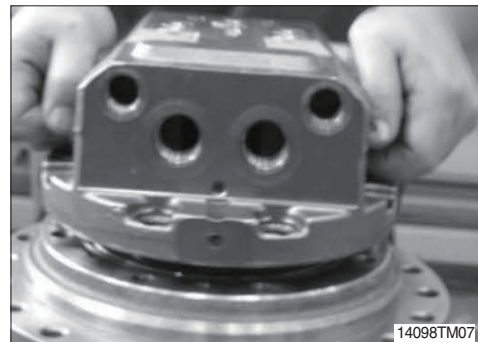

(5) Remove the parallel pin (42) from the spindle (101).

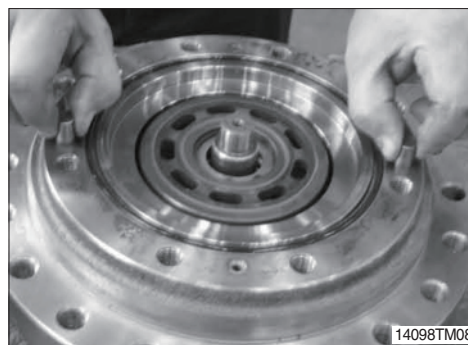

(6) Remove the O-ring (126) from the spindle (101).

※ Do not reuse the O-ring (126).

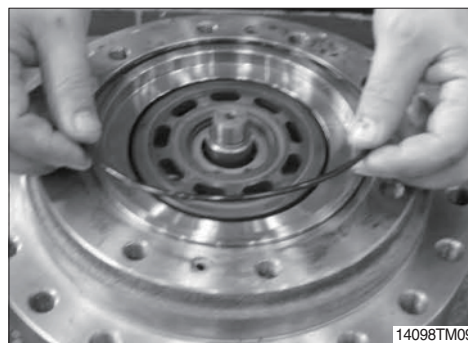

(7) Disassembling the rear flange (1) part

① Place the rear flange with the contact surface of the spindle upward.

② Remove the timing plate (9) from the rear flange (1).

※ When removing the timing plate, user can have difficulty of the removal due to the close adhesion of rear flange (1) and oil. Remove it after fitting a rod through the hole which is used when a casting is detached.

※ Be careful of the leakage due to both surface scratch if using a sharp tool.

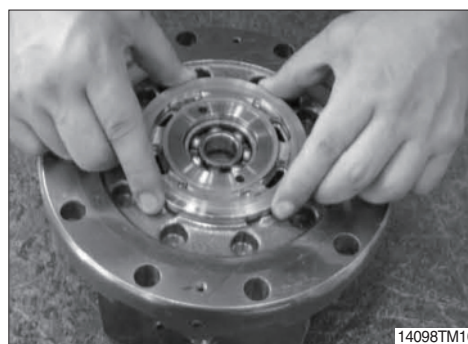

③ Remove the parallel pin (41) from the rear flange (1).

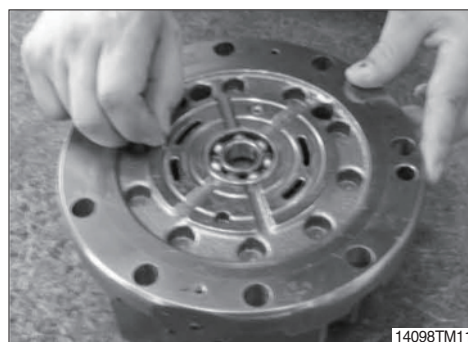

- ④ Remove the ball bearing (50) from the rear flange (1).

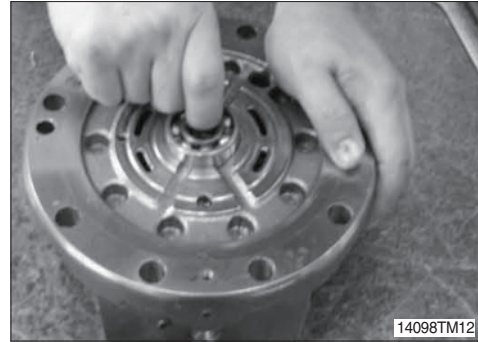

(8) Disassembling the brake valve part

- ① Remove two plugs (24) from the rear flange (1).
- ※ User can work easily if sub-disassembly was done on the reversal table.
 - ※ Tools
 - Hexagon wrench 36
 - Torque wrench

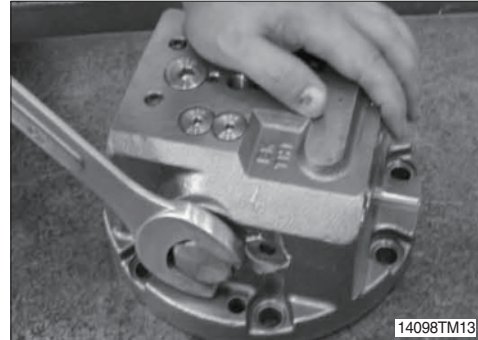

- ② Take out two spring retainers (25), two springs (28) from the rear flange (1).
- ③ Remove the spool (23) from the rear flange (1).
- ※ Be careful not to damage the outer surface of the spool (23) and the sliding surface of the rear flange (1).
 - ※ Since the rear flange (1) and the spool (23) are of the selective fitting type, replace them together as a kit even if only one of the two parts is damaged.

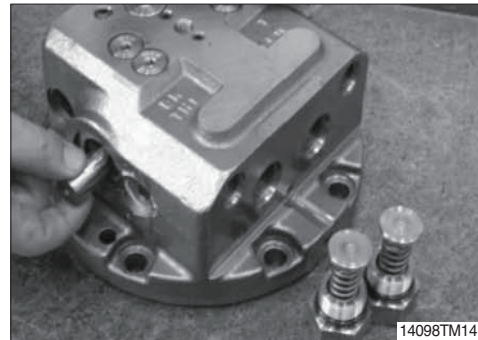

- ④ Remove two plugs (26) from the rear flange (1).
- ※ User can work easily if sub-disassembly was done on the reversal table.
 - ※ Tools
 - Hexagon wrench 10

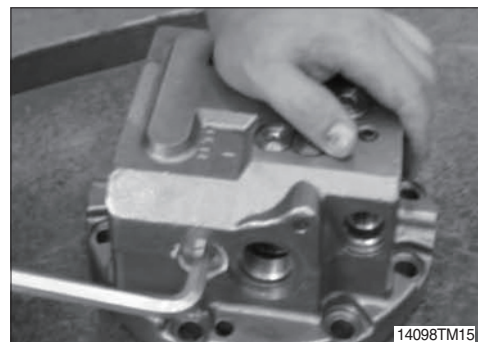

- ⑤ Remove the springs (30, 2EA), valves (27, 2EA) from rear flange (1).

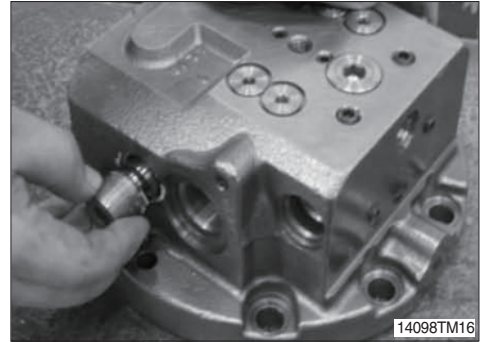

- ⑥ Remove the O-ring (37) from plug (24).
※ Do not reuse the O-ring (37).

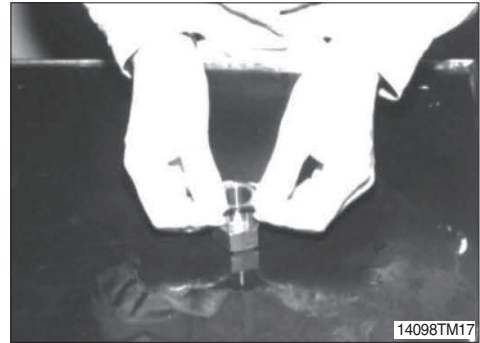

- ⑦ Remove the O-ring (36) from plug (26).
※ Do not reuse the O-ring (36).

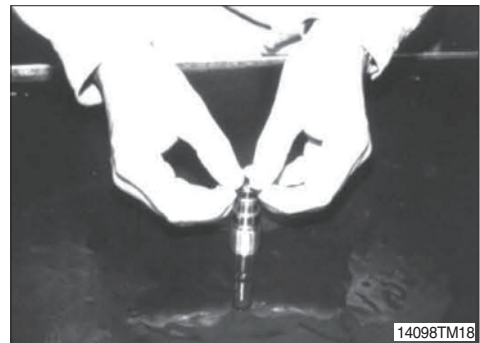

(9) Disassembling the two speed change valve

- ① Remove the plug (63) from the rear flange (1).
※ User can work easily if sub-disassembly was done on the reversal table.
※ Tools
· Hexagon wrench 10

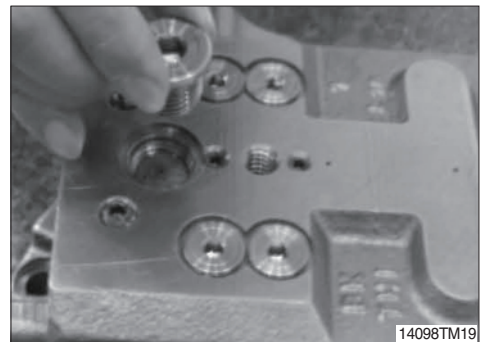

- ② Remove the spool (65) and spring (66) from rear flange (1).

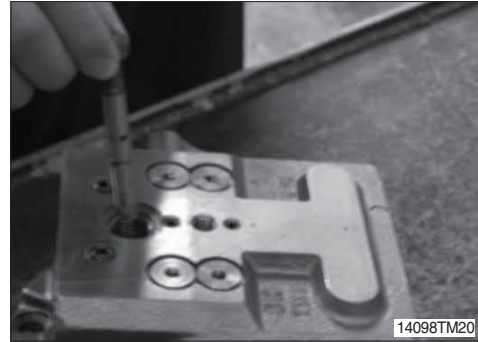

(10) Disassembling the plug (52).

- ① Do not remove plug (52) if it not to be necessary.
Disassembling the plug (52) if it was malfunction because of get mixed with dust.
Clean the plug (52) after disassembled.
- ※ Be careful not to drop the steel ball (68).

(11) Disassembling the parking brake valve (19)

- ① Mount the rear flange (1) on a working bench that the mounting side of the spindle (101) faces upward.
- ② Pushing valve seat (18) by a steel bar, disassemble ring (22) from rear flange (1).

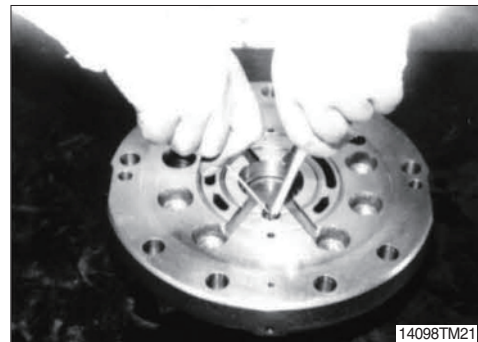

- ※ Do not remove ring (22) if it not to be replace.
- ※ Do not reuse the ring (22), valve seat (18) and O-ring (33).

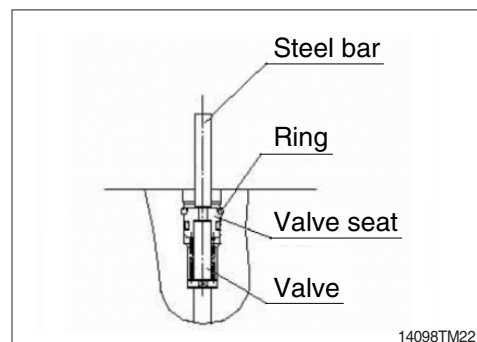

- ③ Remove the valve seat (18) by injecting compressed air from the access hole in the spindle (101) after caulking the hole of valve seat (18).

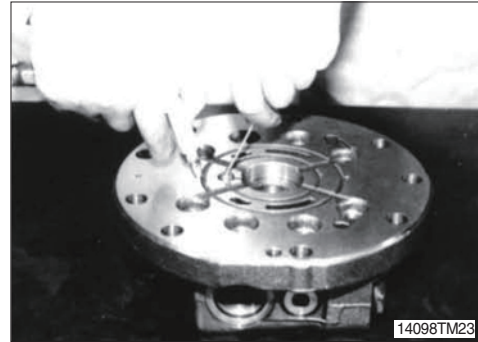

- ④ Remove the valve (19) and spring (20) from rear flange (1) downside hole with shaking lightly.

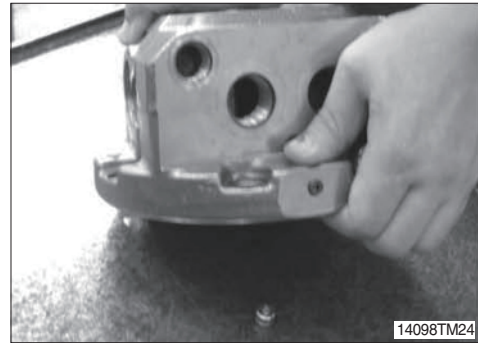

- ⑤ Remove the O-ring (33) and valve seat (18).
※ Do not reuse the O-ring (33).

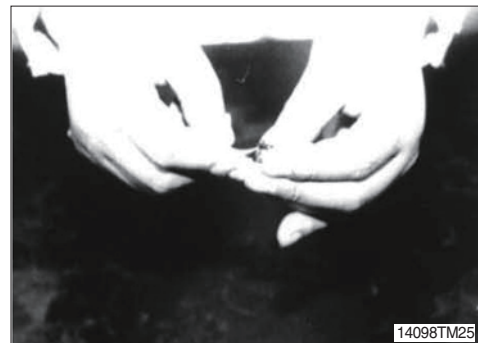

(12) Disassembling the parking brake

- ① Remove the piston (12) by injecting compressed air from the parking brake access hole in the spindle (101).
- ※ Use the protection cover on the upper part of spindle (101) when users put the pressed air into suddenly. Otherwise part damage and accident might go on because the piston (12) is rushed out of the spindle (101).

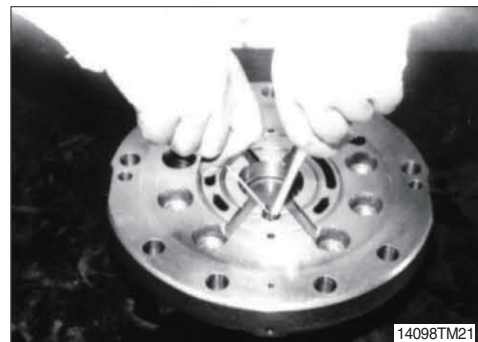

- ② Remove the O-rings (35, 39) and backup rings (47, 48) from the piston (12).
- ※ Do not reuse O-rings (35, 39) and backup rings (47, 48) after removal.

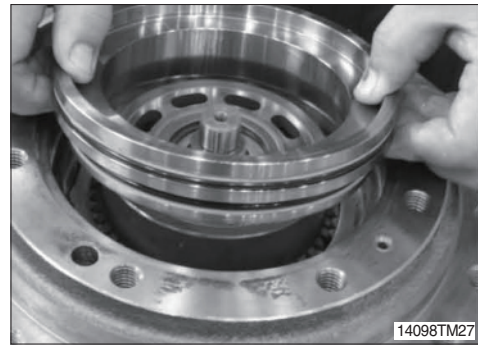

(13) Disassembling the hydraulic motor part

- ① Lay the travel motor body on the side.
- ② Drain out the oil from the travel motor.
- ※ Place an oil receptacle under the travel motor to receive the oil flowing out as the motor is being laid on the side.

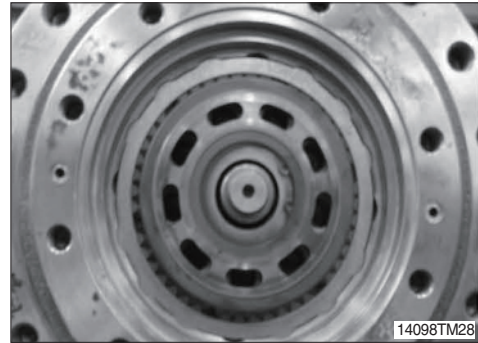

- ③ Hold the cylinder block (4) with both hands, and remove it from the shaft (2).
- ④ Remove the mating plates (16) and friction plates (15) from the cylinder block (4).
- ※ Before removal, hold the cylinder block (4) with both hands and turn it two to three times in a clockwise and a counterclockwise direction alternately to detach the shoe (6) from the swash plate (3).
- ※ Be careful that if an attempt is made to remove the cylinder block (4) without detaching the shoe (6) from the swash plate (3), then the piston, shoe and other parts that are connected to the cylinder block may come the cylinder loose and fall into the spindle (101).

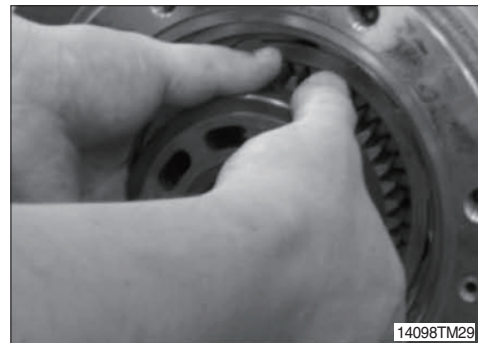

(14) Disassembling the cylinder block kit

- ① Piston assembly [piston (5), shoe (6)] from the removed cylinder block (4).

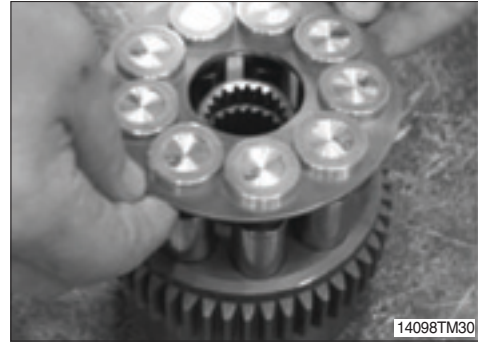

- ② Piston (5) and shoe (6) from the removed retainer plate (7).



- ③ Thrust ball (8) from the removed cylinder block (4).



- ④ Roller (51, 5EA) from the removed cylinder block (204).

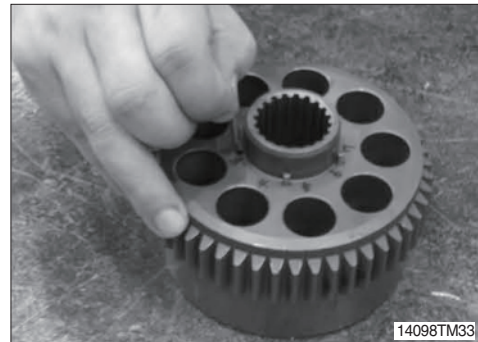

(15) Disassembling the spring of the cylinder block

- ① Put the cylinder block (4) on the pressurize jig.
 - ② Press the washer (10) with pressurize jig, and remove the spring (14) after snap ring (45) removed.
- ※ Put a vinyl cover on the sliding surface of cylinder block (4) for protection.
 - ※ Do not remove spring (14) if it not to be replace.



- ③ Remove the snap ring (45), washer (10), spring (14) and washer (10) from cylinder block (4).



(16) Disassembling the shaft

- ① Remove swash plate (3) from the shaft (2).
 - ② Remove shaft (2) from the spindle (101).
- ※ When separating the swash plate, separate and turn it by using hands to free from intervention of the stopper.

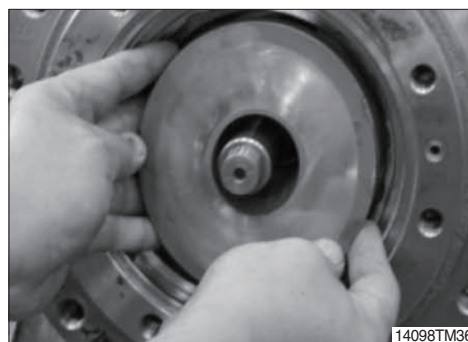

- ③ Remove speed selector piston assembly [piston (61) and shoe (62)] from the spindle [101] by feeding compressed air into the access hole in spindle (101).
 - ④ Remove parallel pins (42, 2EA) and pivots (67, 2EA) from the spindle (101).
 - ⑤ Remove roller bearing (49) from the spindle (101).
- ※ Piston assembly ; Piston (61), Shoe (62)
 - ※ Compressed air ; 3~5 kgf/cm² (43~71 psi)
 - ※ When piston (61) or shoe (62) is damaged, if exchange is necessary, they have to be exchanged together because the separation is impossible. Use the protection cover on the upper part spindle when users put the compressed air into suddenly. Otherwise part damage and accident might go on because the piston is rushed out of the spindle.

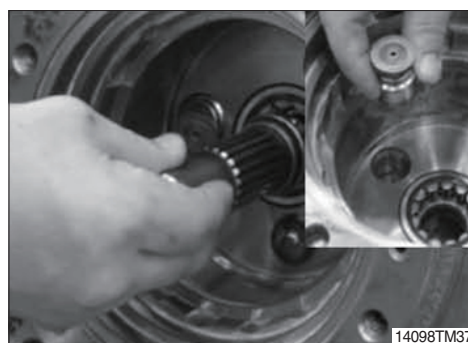

4. REASSEMBLY

4.1 GENERAL PRECAUTIONS

- 1) Reassemble in a work area that is clean and free from dust and dirt.
- 2) Handle parts with bare hands to keep them free of lint contaminants.
- 3) Repair or replace the damaged parts.
Each parts must be free of burrs its corners.
- 4) Do not reuse O-ring, oil seal and floating seal that were removed in disassembly. Provide the new parts.
- 5) Wash all parts thoroughly in a suitable solvent. Dry thoroughly with compressed air.
Do not use the cloths.
- 6) When reassembling oil motor components of travel motor, be sure to coat the sliding parts of the motor and valve with fresh hydraulic oil. (NAS class 9 or above)
- 7) Use a torque wrench to tighten bolts and plugs, to the torque specified as follows.

4.2 REASSEMBLY PROCEDURE

1) REASSEMBLE THE HYDRAULIC MOTOR PART

- (1) Install roller bearing (49) into the spindle (101).
 - (2) Install pivots (67, 2EA), parallel pin (42, 2EA) and two speed piston assembly (61, 62) into the spindle (101).
 - (3) Install shaft (2) into the roller bearing (49) assembled spindle (101).
- ※ Be careful not to damage the seal (3) of assembling part.

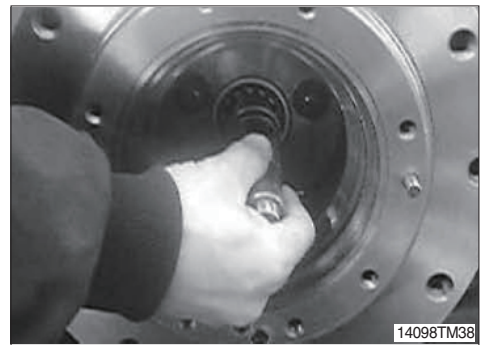

- (4) Lay the travel motor body on the side.
- (5) Apply lithium grease to the shaft (2)'s spline part.
- (6) Install swash plate (3) to the spindle (101).

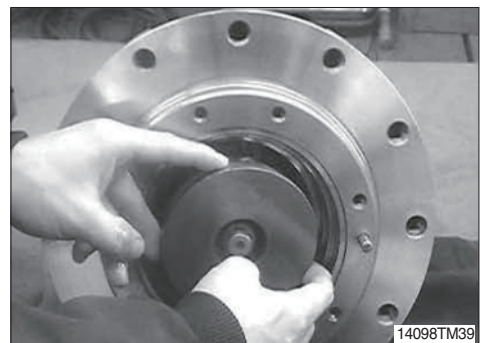

(7) Reassemble the cylinder block kit

- ① Install washer (10), spring (14, 9EA), washer (10) and snap ring (45) in that order, into the cylinder block (4) inner part.
- ② Put the cylinder block (4) on the pressurize jig.



- ③ While pressing washer (10) by pressurize jig, install snap ring (45).
- ※ Put a vinyl cover on the sliding surface of the cylinder block (4) and timing plate (9) for protection.



(8) Reassemble the hydraulic motor

- ① Install roller (51, 5EA) to the pin hole of cylinder block (4).
- ② Install thrust ball (8) to the cylinder block (4).
- ③ Insert piston assembly [piston (61) and shoe (62), 9 set] into retainer plate (7).
- ※ After mounting, immerse the entire them in a working fluid.

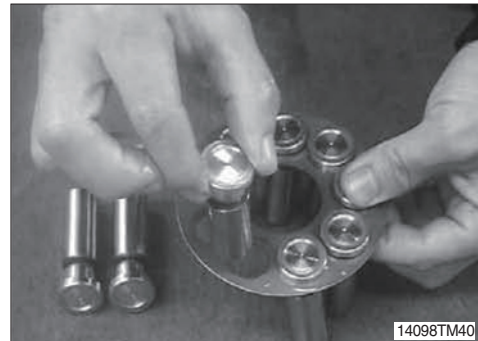

- ④ Mount the piston assembly (9 set) into the cylinder block (4).
- ※ The retainer plate (7) must be in contact with the round part of thrust ball (8).



- ⑤ Install cylinder block (4) assembly to the shaft (2).
- ※ After fitting splines of both cylinder block (4) and shaft (2), assemble them.
- ※ After installing the cylinder (4), confirm whether it revolves or not by turning using both hands.
- ※ Motor is malfunction when it isn't revolve.

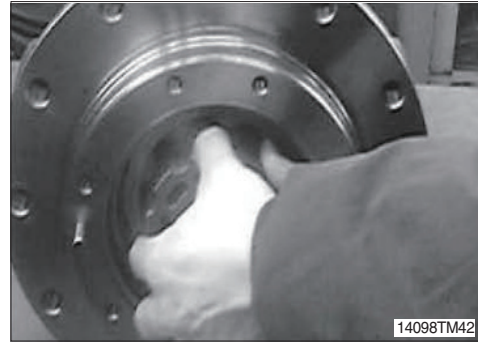

(9) Reassemble the parking brake

- ① Install mating plate (16) first and then a friction plate (15), one by one, into the grooves of the outer surface of the cylinder block (4).
- ※ Immerse the friction plates (15) in a working fluid before fitting them into the grooves.

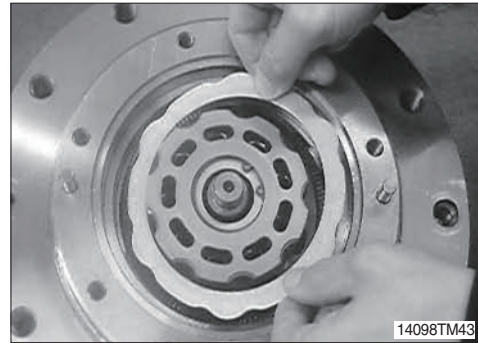

- ② Install two O-rings (35, 39) and two back up ring (47, 48) into O-ring grooves.
- ③ Mount a piston (12) in the spindle (101).
- ※ Apply a thin coat of grease to the O-rings (35, 39).
- ※ If the piston (12) does not fit into the spindle (101) because of the resistance of the O-ring, tap the edge of the piston (12) lightly and equally with a plastic hammer.
- ※ Be careful not to damage the O-ring and back up ring at this time.



2) REASSEMBLE THE REAR FLANGE (1) PART

(1) Reassemble the check valve

- ① Install O-ring (36, 2EA) on the plug (26, 2EA).
- ※ Apply grease to the O-ring (36).



- ② Install spring (30) and valve (27) into the plug (26).
- ③ Install plug (26) into the rear flange (1).
- ※ Install spring (30) and valve (27) into the plug (26), and then grease the spring (30) and the valve (27) and hand-lock the former.

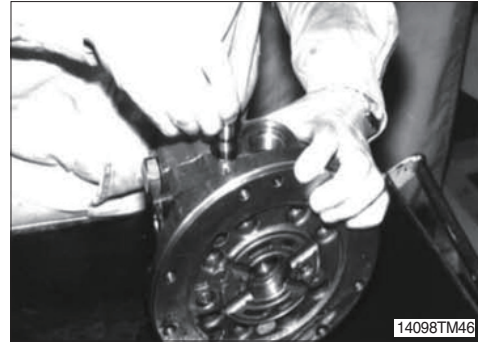

- ④ Install plug (26) in conjunction with the spring (30) and the valve (27) into the rear flange (1), and tighten the plug to the required torque.

※ Tightening torque : 17 ± 2.6 kgf · m (123 ± 18.8 lbf · ft)

※ Tools

- Adapter for hexagon wrench 10
- Torque wrench

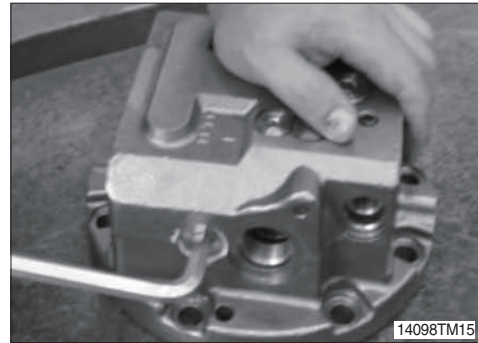

- ⑤ Install spool (23) into the rear flange (1).

※ Before installing the spool (23), apply hydraulic oil to the spool. Be careful not to damage the spool's surface and the inner of rear flange (1).

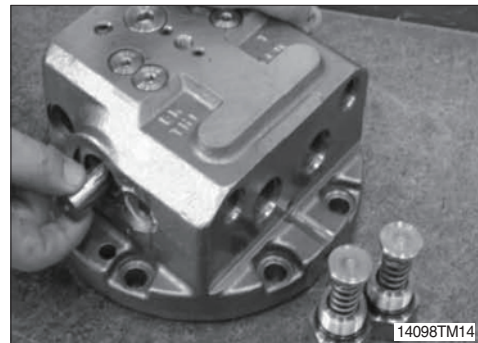

- ⑥ Install O-ring (37) on the plug (24).
Apply grease to the O-ring (37).

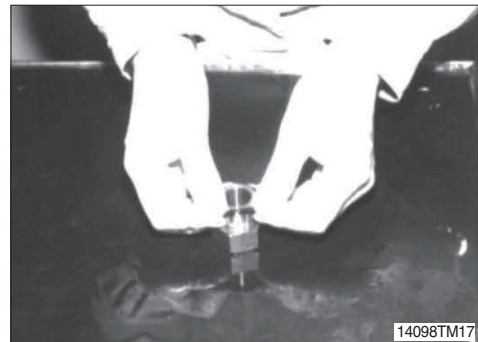

⑦ Install spring retainer (25) and spring (28) into the plug (24).

⑧ Install plug (24) into the rear flange (1).

⑨ Tighten the plug (24) to the required torque.

※ Tightening torque : $36 \pm 5.4 \text{ kgf} \cdot \text{m}$ ($260 \pm 39 \text{ lbf} \cdot \text{ft}$)

※ Socket (#36) / Torque for hexagon wrench.

※ Tools

- Hexagon socket 36
- Torque wrench

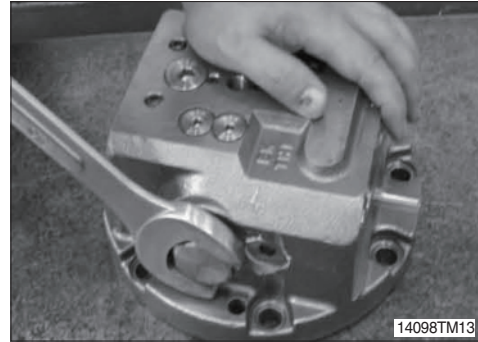

(2) Reassemble the two speed change valve

① Install spring (66) into the valve (65).

② Insert the valve (65) into the rear flange (1).

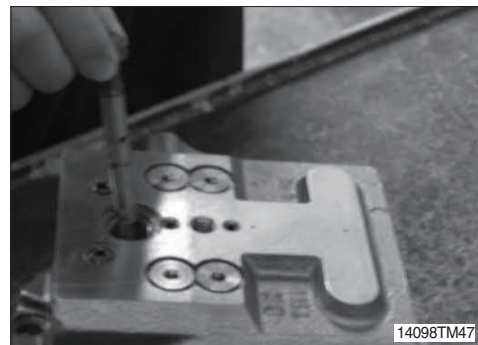

③ Insert a plug (63) into the rear flange (1).

※ Tightening torque : $13 \pm 2.6 \text{ kgf} \cdot \text{m}$ ($94 \pm 18.8 \text{ lbf} \cdot \text{ft}$)

※ Tools

- Adapter for hexagon wrench 10
- Torque wrench

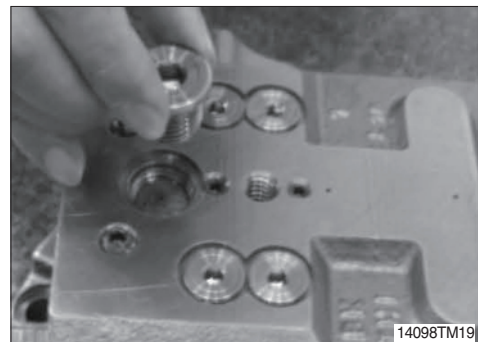

(3) Reassemble the parking brake valve

① Install O-ring (33) on the valve seat (18).

※ Do not reuse the O-ring (33).



- ② Mount the rear flange (1) on a working bench that the mounting side of the spindle (101) faces upward.
- ③ Install valve (19), spring (20) and valve seat (18) in that order.

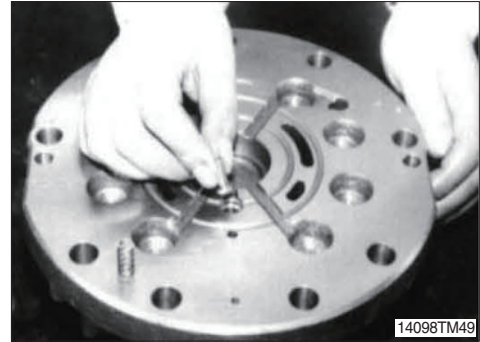

- ④ After new ring (22) bend somewhat and put the valve seat (18), then into the rear flange (1) ring's groove.
- ※ Do not reuse the ring (22).

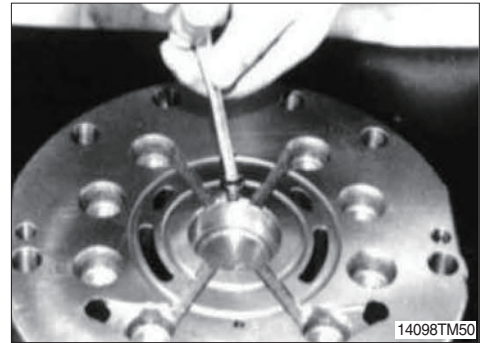

- ⑤ Install ball bearing (50) into the rear flange (1).
- ※ Apply hydraulic oil to the ball bearing (50).



- ⑥ Install parallel pin (41) into the pin hole of rear flange (1).

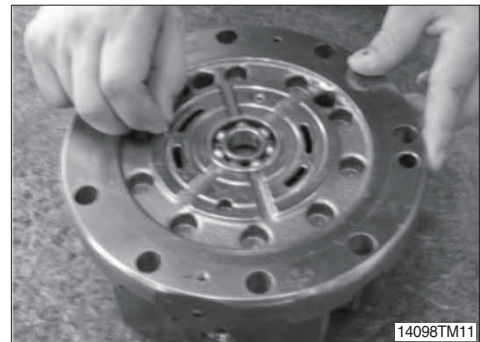

- ⑦ Install timing plate (9) into the rear flange (1).
※ Apply hydraulic oil to the contact surface of rear flange.

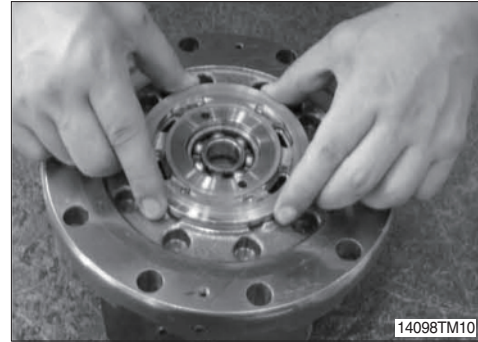

(4) Reassemble the rear flange (1) and spindle (101)

- ① Tilt the work bench 90° for travel motor reassembling.
② Insert the O-ring (75, 126) on the spindle (101).
※ Apply grease to the O-rings (75, 126) thinly.



- ③ Install parallel pins (42, 2EA) into the spindle (101).



- ④ Mount the rear flange (1) on the spindle (101).
※ When the rear flange (1) is mounted on the spindle (101), fix the spring (13) applied grease to not drop.

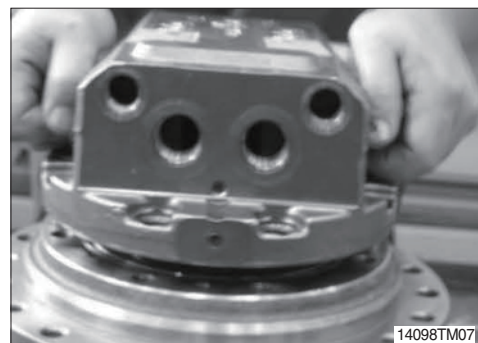

⑤ Tighten the socket bolt (43) into the spindle (101) to the required torque.

※ Tightening torque : $5.9 \pm 1.0 \text{ kgf} \cdot \text{m}$ ($42.7 \pm 7.2 \text{ lbf} \cdot \text{ft}$)

※ Tools

- Adapter for hexagon wrench 8
- Torque wrench

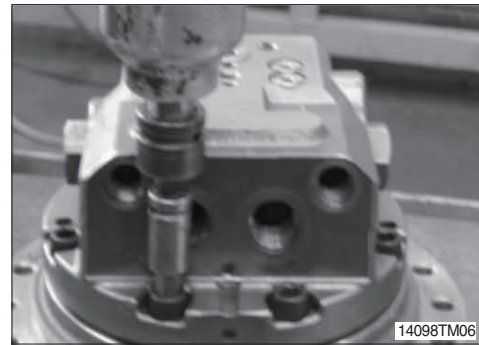

⑥ Tighten the plug (24) into the rear flange (1) to the required torque.

※ Tightening torque : $13 \pm 4.0 \text{ kgf} \cdot \text{m}$ ($94 \pm 28.9 \text{ lbf} \cdot \text{ft}$)

※ Tools

- Hexagon socket 36
- Torque wrench



⑦ Tighten the plug (26) into the rear flange (1) to the required torque.

※ Tightening torque : $36 \pm 1.5 \text{ kgf} \cdot \text{m}$
($260 \pm 10.8 \text{ lbf} \cdot \text{ft}$)

※ Tools

- Hexagon socket 10
- Torque wrench



3) REASSEMBLE THE REDUCTION GEAR ASSEMBLY

(1) Install floating seal (102) on the spindle (101).

※ Apply grease to the floating seal (102).



(2) Install angular bearing (125) and snap ring (106) into the hub (105).

※ Be careful for the insert direction.

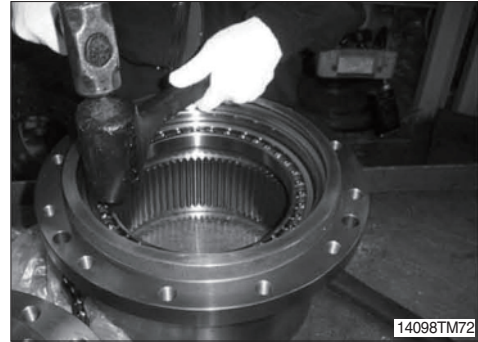

(3) Insert the O-ring (130), the sealing (129) and floating seal (102) in the hub (105).

※ Apply grease to the floating seal (102) thinly.

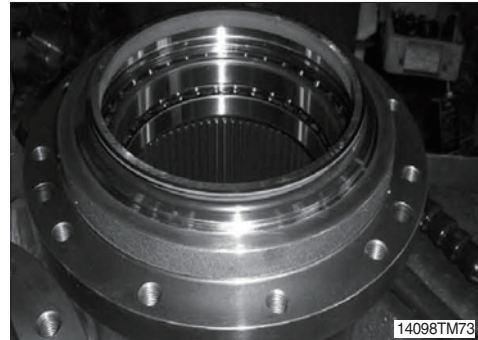

(4) Install the spindle (101) into the hub (105) assembly.

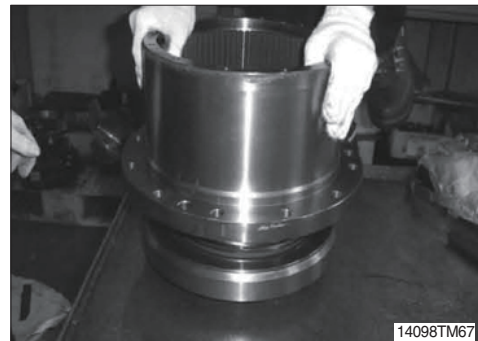

(5) Tighten the nut ring (103) and plug (104) into the hub (105) to the required torque.

※ Do not wind the seal tape to the plug (104).

※ Punch two place for not to loosen the plug (104).

※ Tightening torque : 3.5 ± 0.7 kgf · m (25.3 ± 5.1 lbf · ft)

· Hexagon socket 8

· Torque wrench



(6) Install thrust washer (109) and collar (112) into the hub (105).

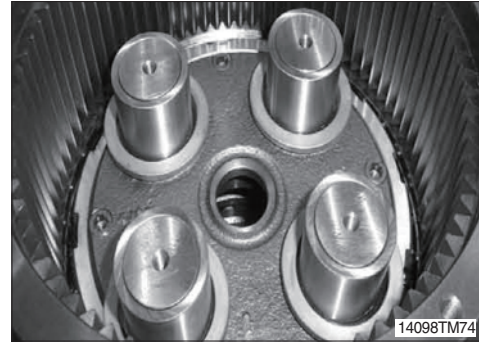

(7) Install needle bearing (111) planetary gear F (108), thrust washer (109), thrust plate F (113) and screw (110) into the hub (105).

- ※ Tightening torque : 0.83 kgf · m (6.0 lbf · ft)
- Hexagon socket 5
- Torque wrench

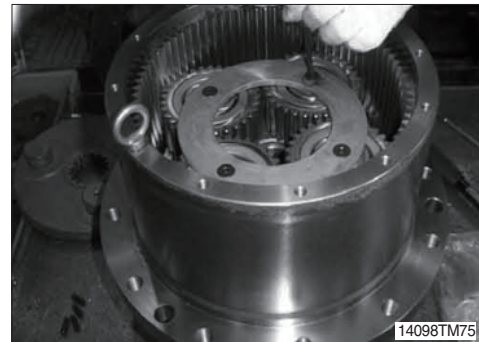

(8) Install sun gear (14) and holder assembly, then insert needle bearing (118) and planetary gear R (117) into the hub (105).

- ※ Holder assembly : holder (116) + spring pin (120) + inner race (119)

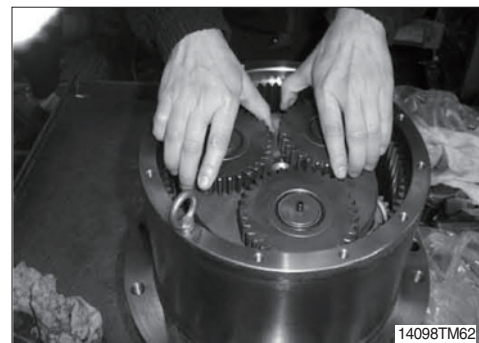

(9) Install drive gear (121) and thrust plate R (122) into the hub (105).

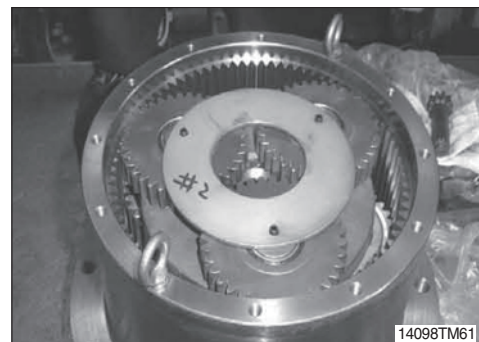

- (10) Install cover (123), thrust plate (150), plug (301, 128) and socket bolt (124) into the hub (105).
※ Apply grease to the cover (123) after installed O-ring (127).

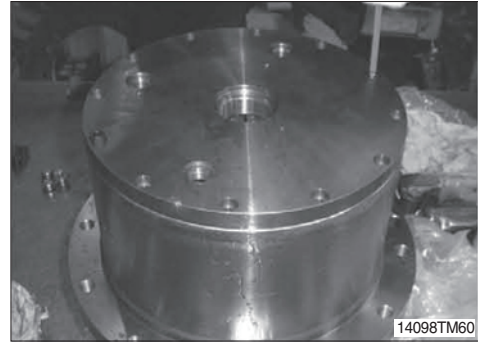

(11) Pressing the oil seal

- ① Insert the oil seal (32) by hit the pressurize jig with plastic hammer.
※ Apply grease to the seat of oil seal (32).

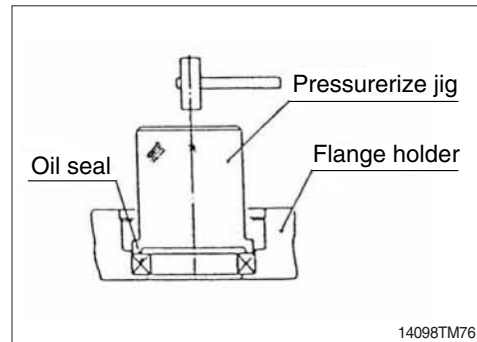

3.3 CHECKING FACTS AFTER ASSEMBLY

1) AIR TEST OF REDUCTION GEAR

Disassemble plug (128) of reduction gear part. When compressed air (0.3 kgf/cm^2) is inserted that in water during the 2 minutes, it should be not happened air bubble.

Fill the gear oil.

- Oil amount : 3.0 liter (0.79 U.S.gallon)

2) AIR TEST OF HYDRAULIC MOTOR

One port should be opened, the others port should be closed. When compressed air (3 kgf/cm^2) is inserted opened port in water during the 2 minutes, it should be not happened air bubble.

Fill the hydraulic oil.

- Oil amount : 0.55 liter (0.15 U.S.gallon)