

ELECTRICAL CIRCUIT(2/2)

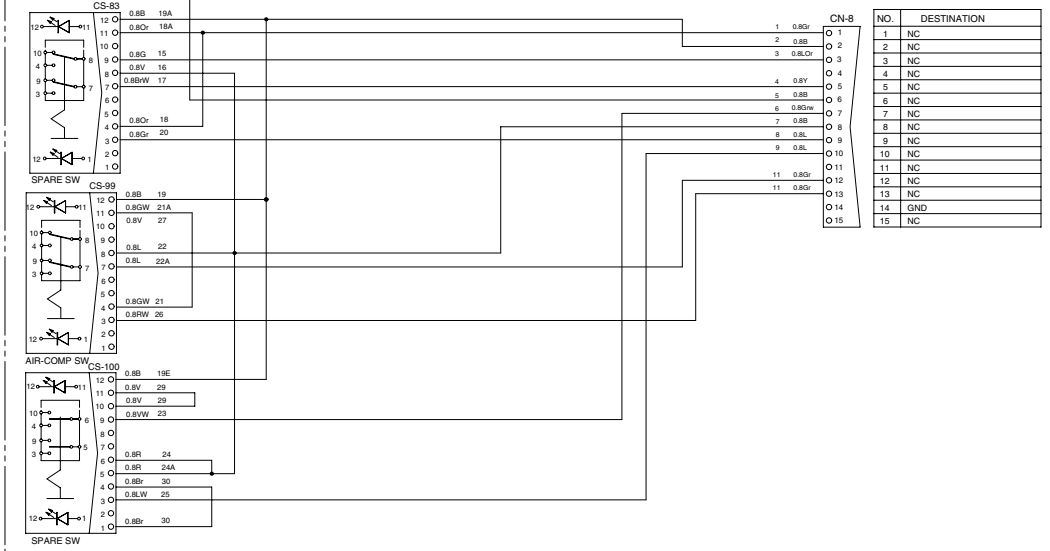
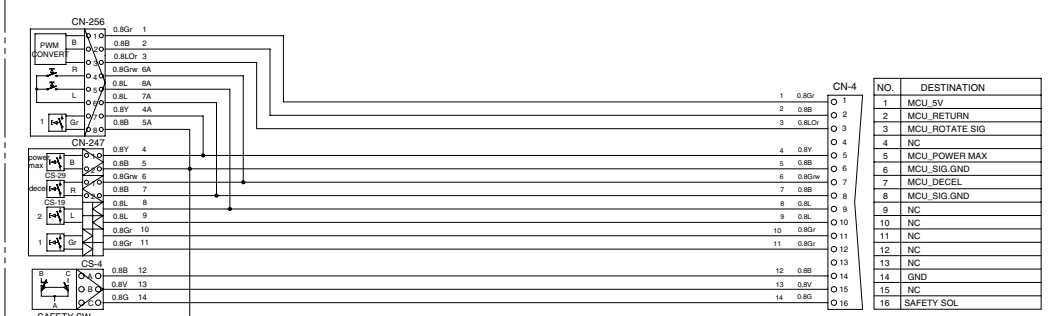
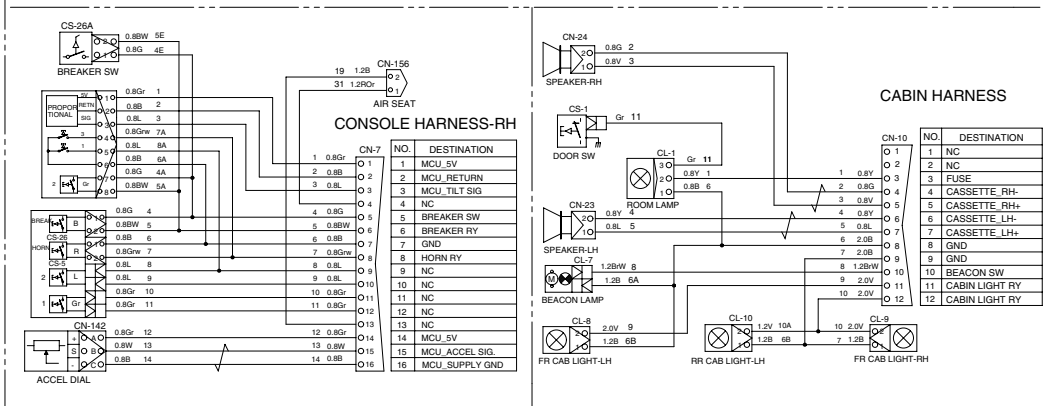
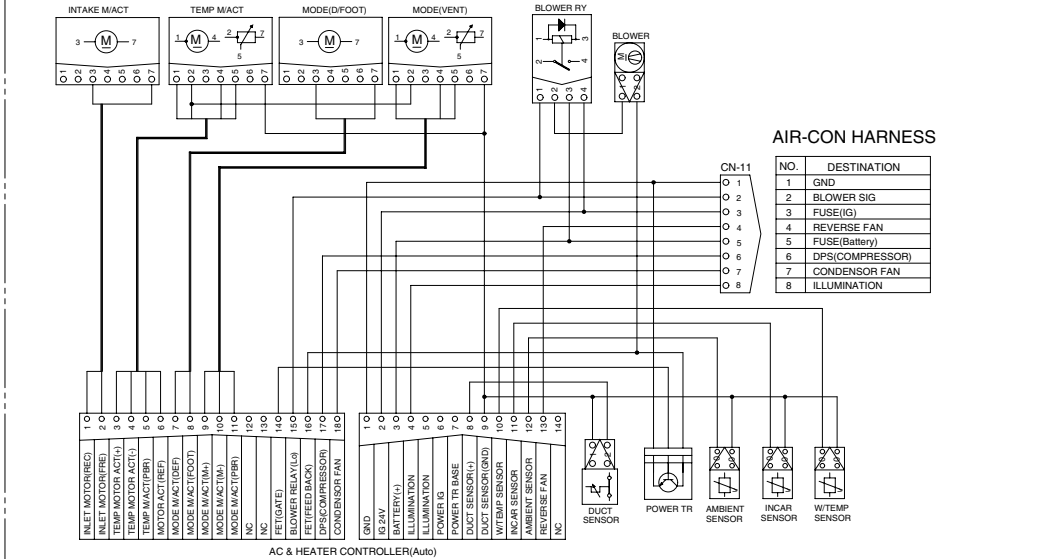
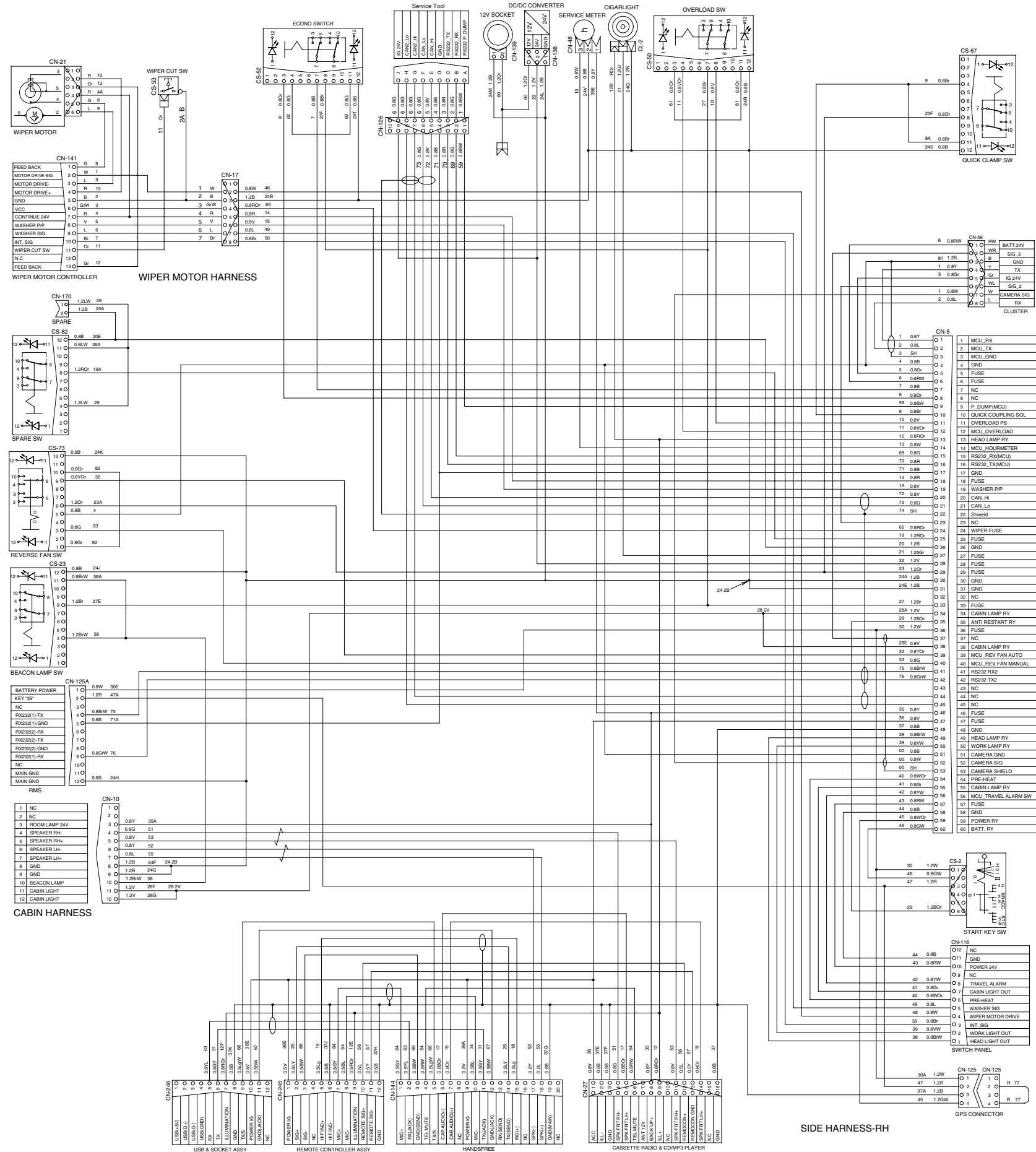

NO.	DESTINATION
1	GND
2	BLOWER SIG
3	FUSE(G)
4	REVERSE FAN
5	FUSE(BATTERY)
6	DPS(COMPRESSOR)
7	CONDENSOR FAN
8	ILLUMINATION

NO.	DESTINATION
1	NC
2	NC
3	FUSE
4	CASSETTE RH-
5	CASSETTE LH-
6	CASSETTE LH+
7	NC
8	GND
9	GND
10	BEACON SW
11	CABIN LIGHT RY
12	CABIN LIGHT RY

NO.	DESTINATION
1	MCU SV
2	MCU RETURN
3	MCU ROTATE SIG
4	NC
5	MCU POWER MAX
6	MCU SIG GND
7	MCU DECEL
8	MCU SIG GND
9	NC
10	NC
11	NC
12	NC
13	NC
14	GND
15	NC
16	SAFETY SOL

NO.	DESTINATION
1	NC
2	NC
3	NC
4	NC
5	NC
6	NC
7	NC
8	NC
9	NC
10	NC
11	NC
12	NC
13	NC
14	GND
15	NC

MEMORANDUM

HYUNDAI HEAVY INDUSTRIES CO., LTD
CONSTRUCTION EQUIPMENT DIV.

1. POWER CIRCUIT

The negative terminal of battery is grounded to the machine chassis through master switch.
When the start switch is in the OFF position, the current flows from the positive battery terminal as shown below.

1) OPERATING FLOW

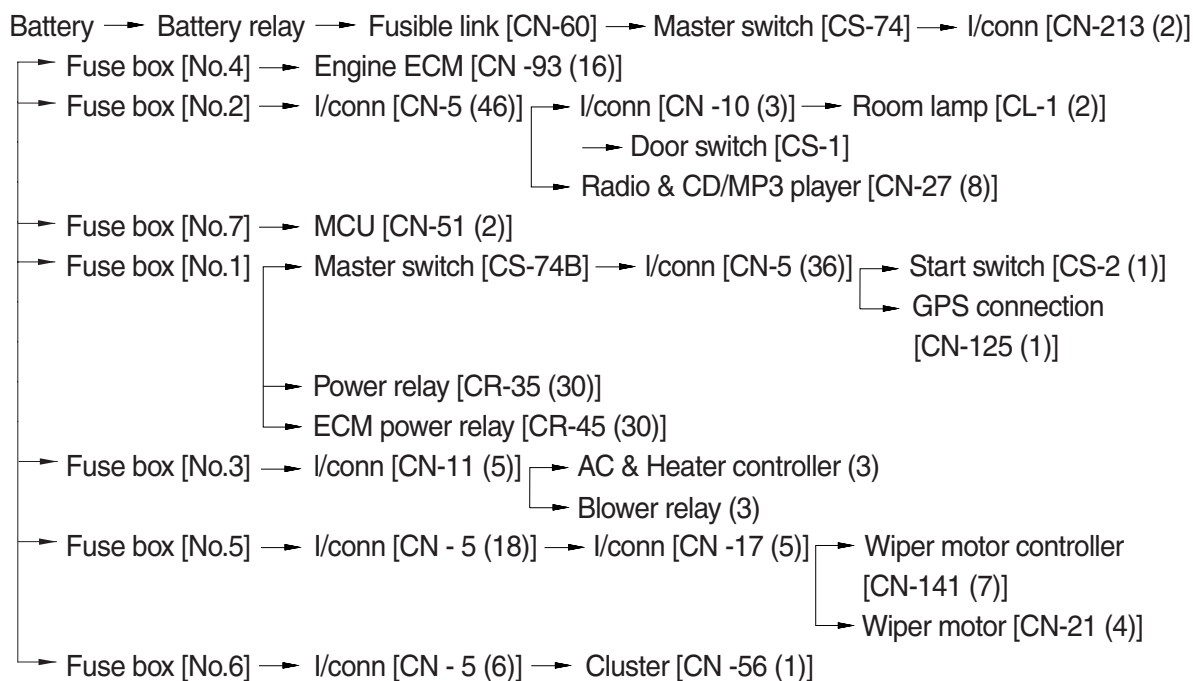

※ I/conn : Intermediate connector

2) CHECK POINT

Engine	Start switch	Check point	Voltage
OFF	OFF	① - GND (battery 1EA) ② - GND (battery 2EA) ③ - GND (battery 2EA) ④ - GND (fusible link)	10~12.5V 20~25V 20~25V 20~25V

※ GND : Ground

POWER CIRCUIT

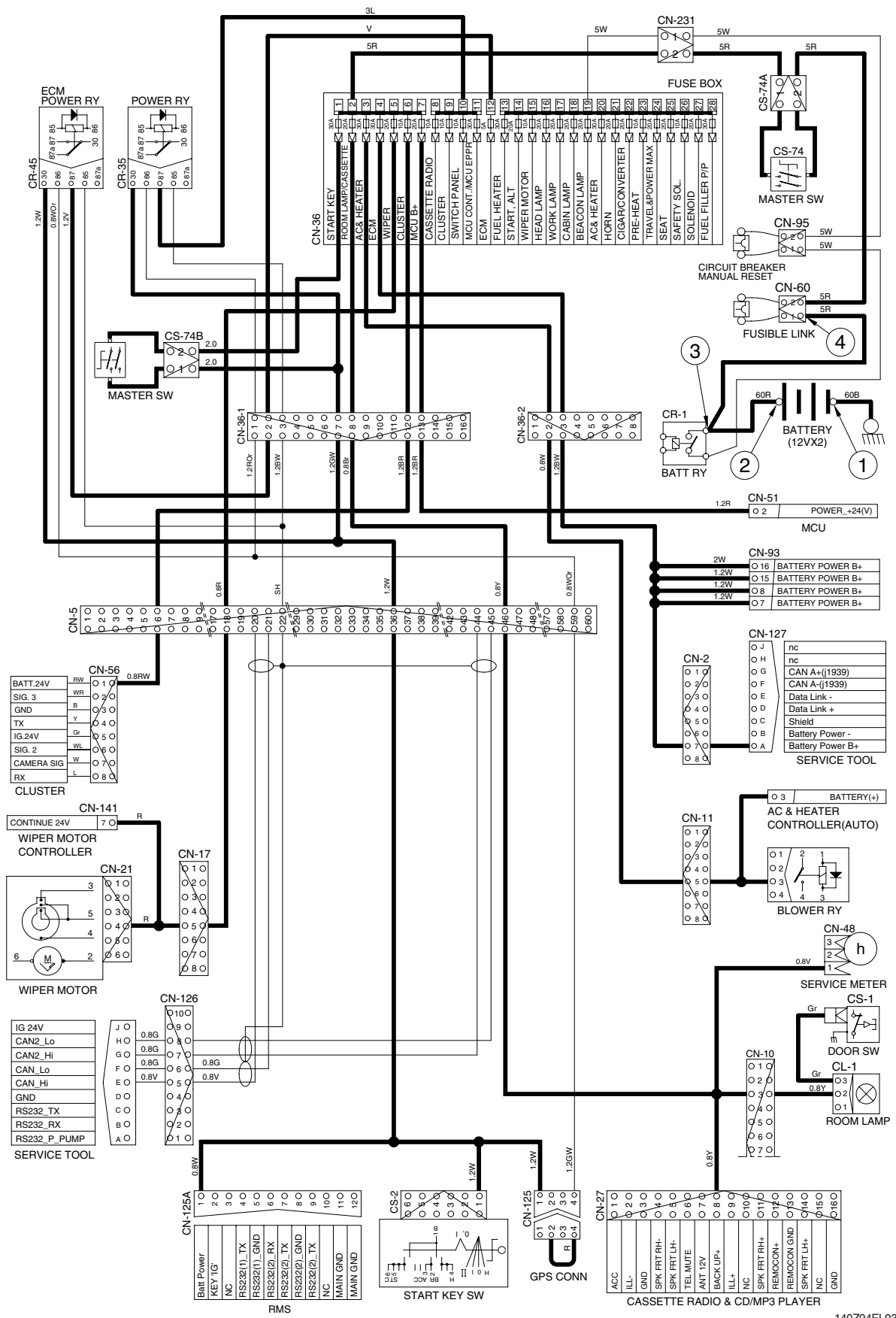

140Z94EL03

2. STARTING CIRCUIT

1) OPERATING FLOW

Battery(+) terminal → Battery relay [CR-1] → Fusible link [CN-60] → Master switch [CS-74]
 → I/conn [CN-231 (2)] → Fuse box [No.1] → Master switch [CS-74B] → I/conn [CN-36-1 (7)]
 → I/conn [CN-5(36)] → Start switch [CS-2(1)]

(1) When start key switch is in ON position

→ Start switch ON [CS-2 (2)] → I/conn [CN-5 (60)] → Battery relay [CR-1]
 → Battery relay operating (all power is supplied with the electric component)
 → Start switch ON [CS-2 (3)] → GPS connector [CN-125 (2)→(4)] → I/conn [CN-5 (59)]
 → Power relay [CR-35 (86) → (87)] → Fuse box [No.10]
 → ECM power relay [CR-45 (86) → (87)] → Fuse box [No.12]

(2) When start key switch is in START position

Start switch START [CS-2 (6)] → I/conn [CN-5 (35)] → Anti-restart relay [CR-5 (86) → (87)]
 → I/conn [CN-2 (2)] → Start relay [CR-23]

2) CHECK POINT

Engine	Start switch	Check point	Voltage
OPERATING	START	① - GND (battery) ② - GND (start key) ③ - GND (battery relay M4) ④ - GND (starter B+) ⑤ - GND (starter M) ⑥ - GND (start relay) ⑦ - GND (battery relay M8)	20~25V

※ GND : Ground

STARTING CIRCUIT

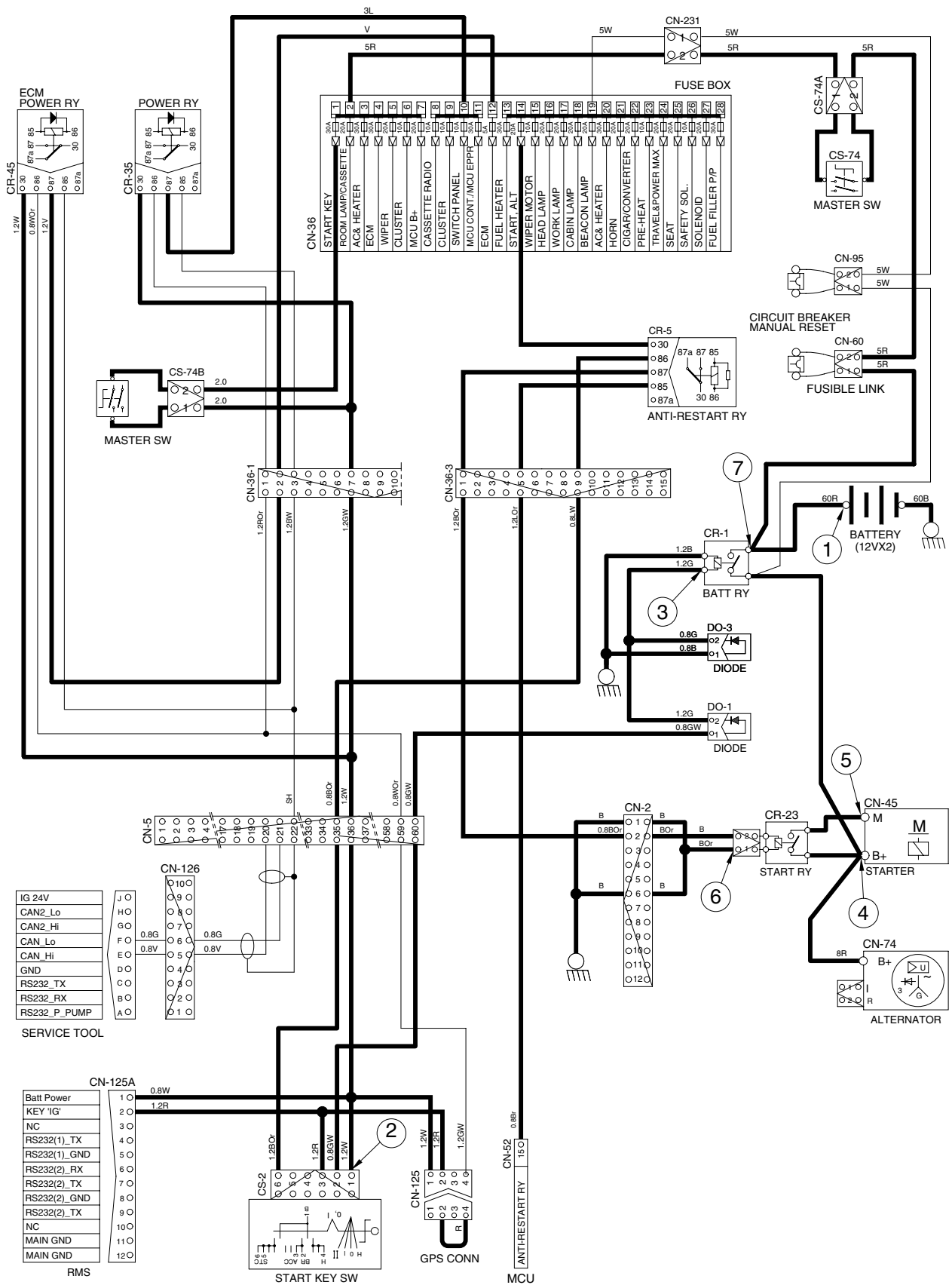

140Z94EL04

3. CHARGING CIRCUIT

When the starter is activated and the engine is started, the operator releases the key switch to the ON position.

Charging current generated by operating alternator flows into the battery through the battery relay [CR-1].

The current also flows from alternator to each electrical component and controller through the fuse box.

1) OPERATING FLOW

(1) Warning flow

Alternator "I" terminal → I/conn [CN-2 (3)] → MCU alternator voltage level [CN-51 (39)]
 Cluster charging warning lamp(Via serial interface)

(2) Charging flow

Alternator "B+" terminal → Battery relay(M8) → Battery(+) terminal
 → Fusible link [CN-60] → Master switch [CS-74]
 → I/conn [CN-231 (2)] → Fuse box

2) CHECK POINT

Engine	Start switch	Check point	Voltage
Run	ON	① - GND (battery voltage) ② - GND (battery relay) ③ - GND (alternator B ⁺ terminal) ④ - GND (alternator I terminal) ⑤ - GND (MCU)	20~30V

※ GND : Ground

CHARGING CIRCUIT

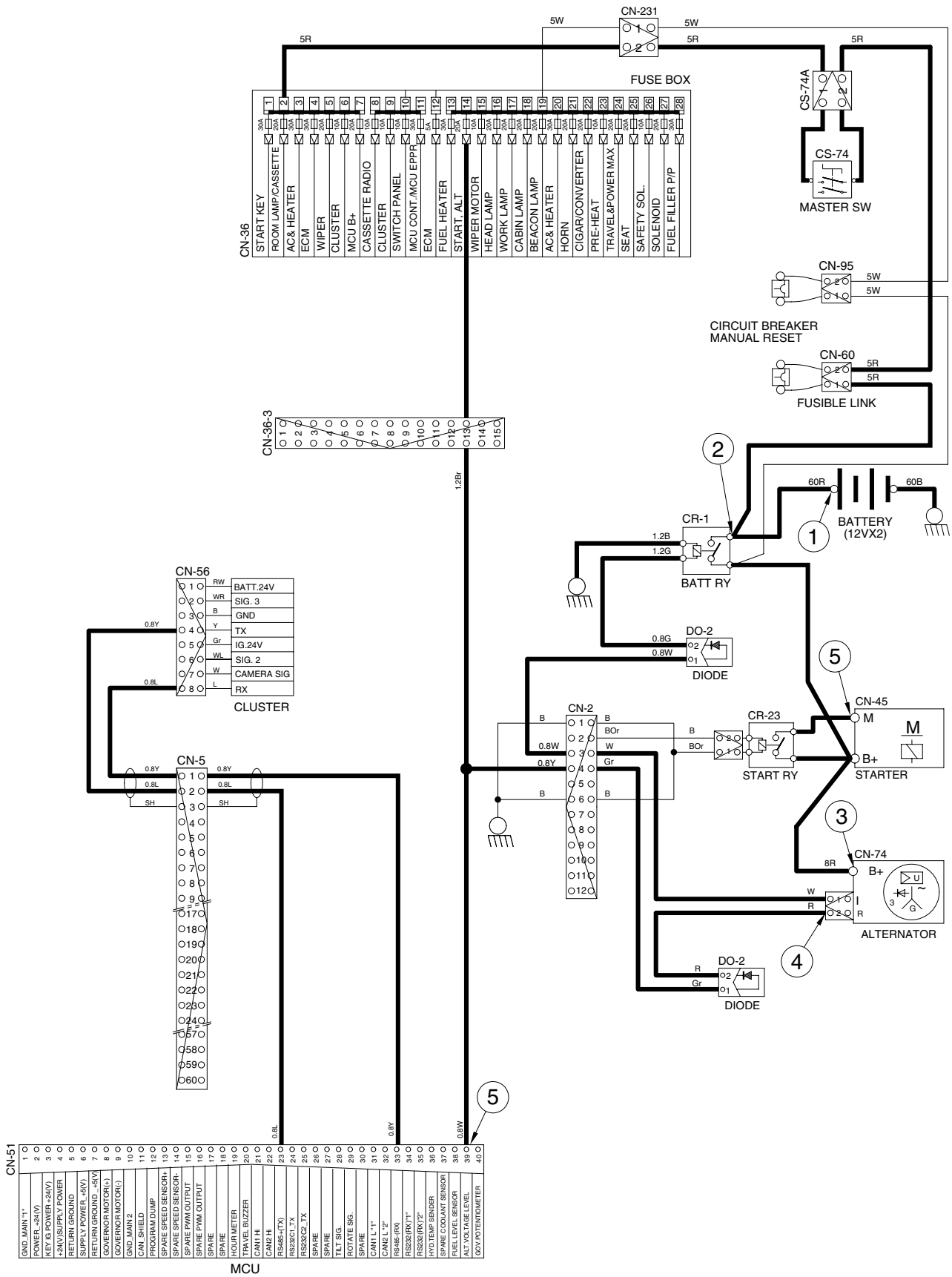

4. HEAD AND WORK LIGHT CIRCUIT

1) OPERATING FLOW

Fuse box (No.16) → Head light relay [CR-13 (30,86)]

Fuse box (No.17) → Work light relay [CR-4 (30,86)]

(1) Head light switch ON

Head light switch ON [CN-116 (1)] → I/conn [CN-5 (49)] → Head light relay [CR-13 (85) → (87)]

→ Head light ON [CL-3 (1)] , [CL-4 (1)]

→ I/conn [CN-11 (8)] → AC & Heater controller illumination ON [4]

→ I/conn [CN-5 (13)] → Remote controller illumination ON [CN-245 (9)]

→ Cigar light [CL-2]

→ USB & Socket illumination ON [CN-246 (7)]

→ Radio & CD/MP3 player illumination ON [CN-27 (9)]

(2) Work light switch ON

Work light switch ON [CN-116 (2)] → I/conn [CN-5 (50)] → Work light relay [CR-4 (85) → (87)]

→ I/conn [CN-12 (1)] → Work light ON [CL-5 (2), CL-6 (2)]

2) CHECK POINT

Engine	Start switch	Check point	Voltage
STOP	ON	① - GND (fuse box) ② - GND (switch power output) ③ - GND (head light relay) ④ - GND (head light) ⑤ - GND (fuse box) ⑥ - GND (switch power output) ⑦ - GND (work light relay) ⑧ - GND (work light)	20~25V

※ GND : Ground

HEAD AND WORK LIGHT CIRCUIT

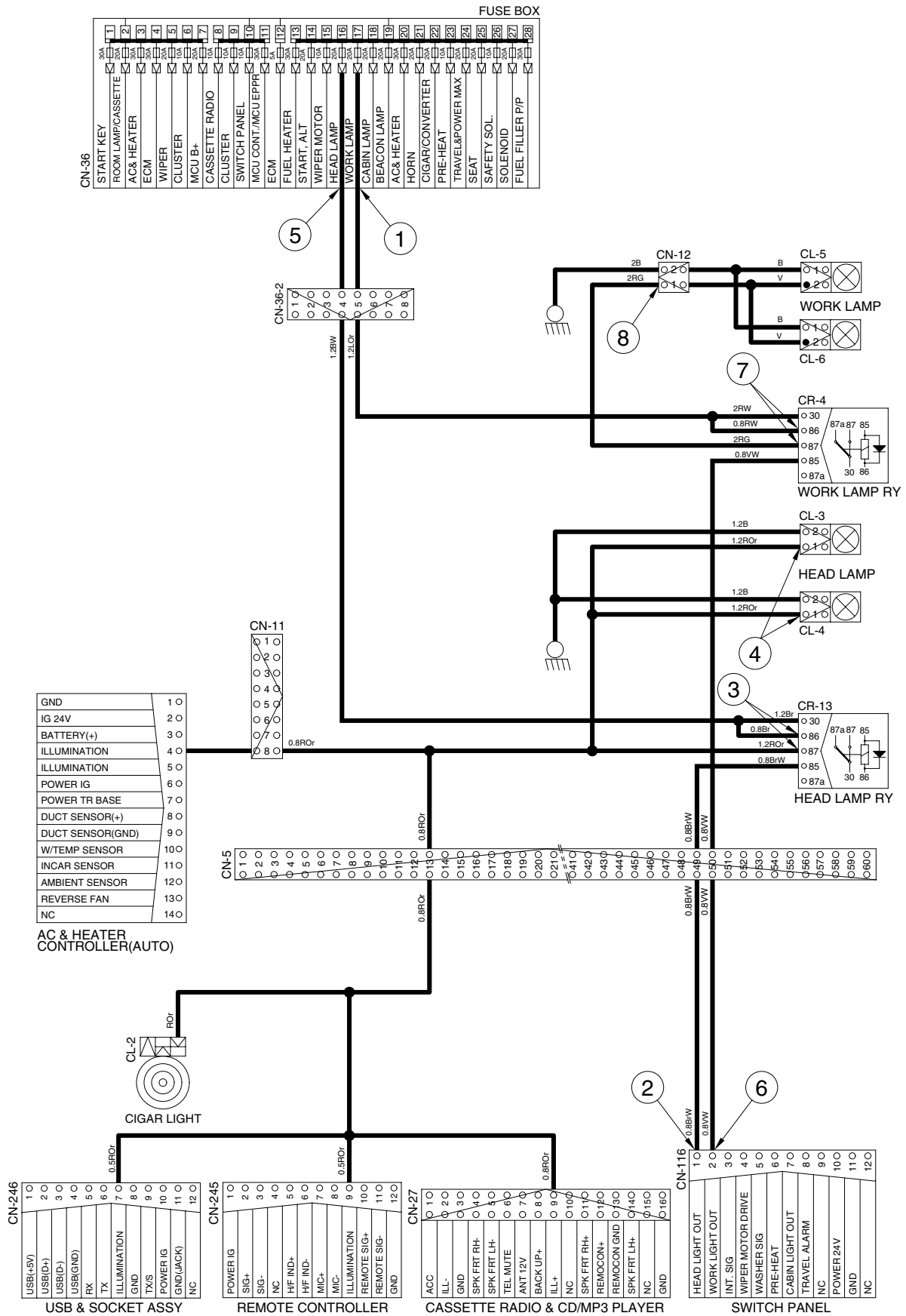

5. BEACON LAMP AND CAB LIGHT CIRCUIT

1) OPERATING FLOW

Fuse box (No.19) → I/conn [CN-5 (33)] → Beacon lamp switch [CN-23 (8)]

Fuse box (No.18) → Cab light relay [CR-9 (30, 86)]

(1) Beacon lamp switch ON

Beacon lamp switch ON [CS-23 (4)] → Switch indicator lamp ON [CS-23 (11)]
 → I/conn [CN-10 (10)] → Beacon lamp ON [CL-7]

(2) Cab light switch ON

Cab light switch ON [CN-116 (7)] → I/conn [CN-5 (55)] → Cabin lamp relay [CR-9 (85) → (87)]

→ I/conn [CN-5 (34, 38)] → I/conn [CN-10 (11)] → Front cab light ON [CL-8 (2)]
 → I/conn [CN-10 (12)] → Front cab light ON [CL-9 (2)]
 → Rear cab light ON [CL-10 (2)]

2) CHECK POINT

Engine	Start switch	Check point	Voltage
STOP	ON	① - GND (fuse box) ② - GND (switch power input) ③ - GND (switch power output) ④ - GND (beacon lamp)	20~25V
STOP	ON	⑤ - GND (fuse box) ⑥ - GND (cabin light relay) ⑦ - GND (switch power output) ⑧ - GND (cab light)	20~25V

※ GND : Ground

BEACON LAMP AND CAB LIGHT CIRCUIT

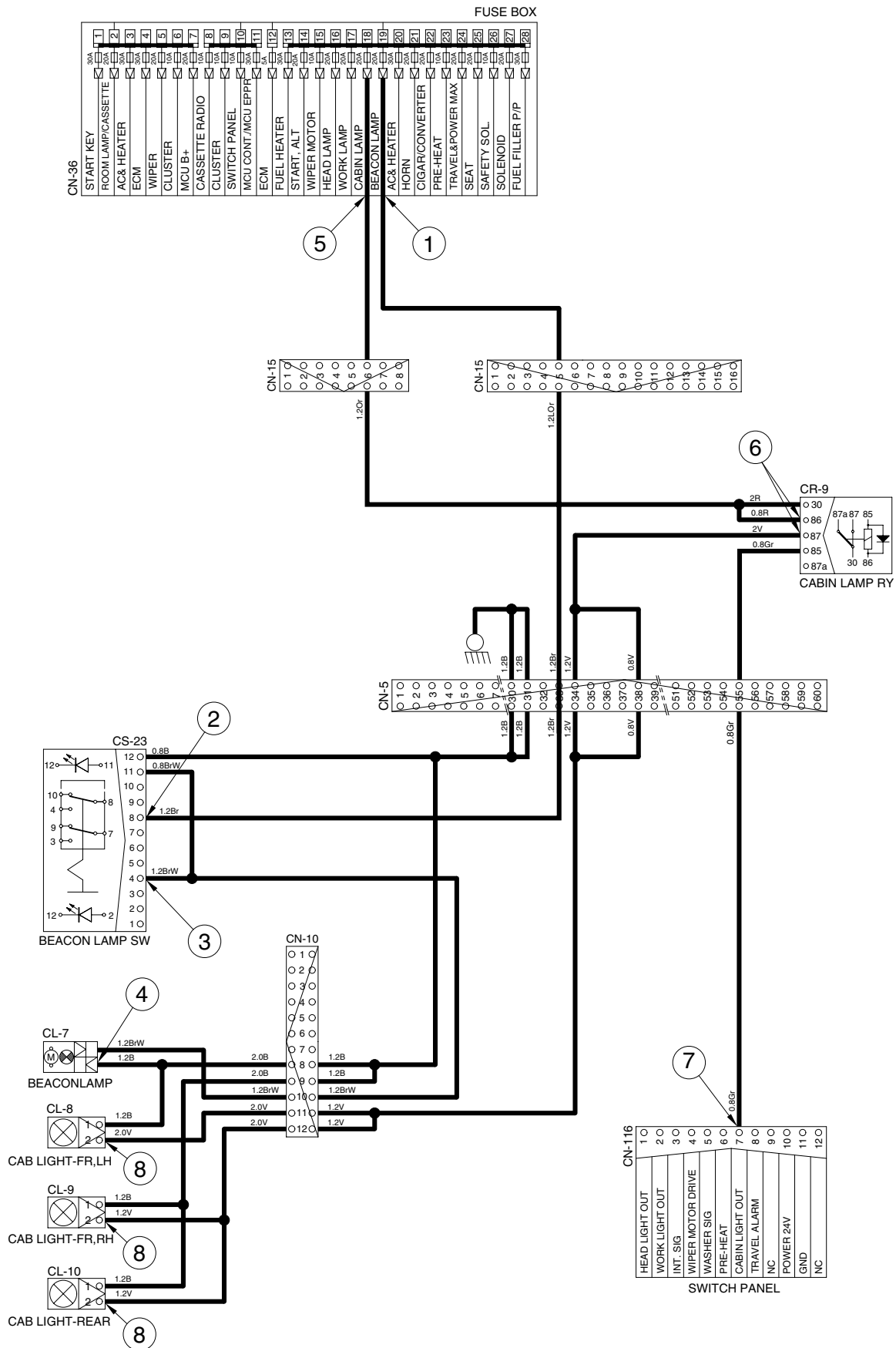

6. WIPER AND WASHER CIRCUIT

1) OPERATING FLOW

(1) Key switch ON

Fuse box (No.10) → I/conn [CN-5 (57)] → Switch panel [CN-116 (10)]

Fuse box (No.5) → I/conn [CN-5 (18)] → I/conn [CN-17 (5)] → Wiper motor controller [CN-141(7)]
 → Wiper motor [CN-21(4)]

Fuse box (No.15) → I/conn [CN-5 (24)] → I/conn [CN-17 (4)] → Wiper motor controller [CN-141 (6)]
 → Washer pump [CN-22 (2)]

(2) Wiper switch ON : 1st step (Intermittent)

Wiper switch ON [CN-116 (3)] → I/conn [CN-17 (8)] → Wiper motor controller [CN-141 (10) → (3)]
 → Wiper motor intermittently operating [CN-21 (6)]

(3) Wiper switch ON : 2nd step (continual)

Wiper switch ON [CN-116(4)] → I/conn[CN-17(2)] → Wiper motor controller [CN-141(2) → (4)]
 → Wiper motor operating [CN-21(2)]

(4) Washer switch ON

Washer switch ON [CN-116 (5)] → I/conn [CN-17 (7)] → Wiper motor controller [CN-141 (9) → (8)]
 → I/conn [CN-17 (6)] → I/conn [CN-5 (19)] → Washer pump [CN-22 (1)] → Washer operating
 Wiper switch ON [CN-116 (4)] → I/conn[CN-17 (2)] → Wiper motor controller [CN-141 (2) → (4)]
 → Wiper motor operating [CN-21 (2)]

(5) Auto parking (when switch OFF)

Switch OFF [CN-116 (4)] → Wiper motor parking position by wiper motor controller

2) CHECK POINT

Engine	Start switch	Check point	Voltage
STOP	ON	① - GND (fuse box)	24V
		② - GND (switch power input)	
		③ - GND (switch power output)	0 ~ 5V
		④ - GND (wiper power input)	
		⑤ - GND (wiper power output)	24V
		⑥ - GND (wiper motor)	0 or 24V

※ GND : Ground

WIPER AND WASHER CIRCUIT

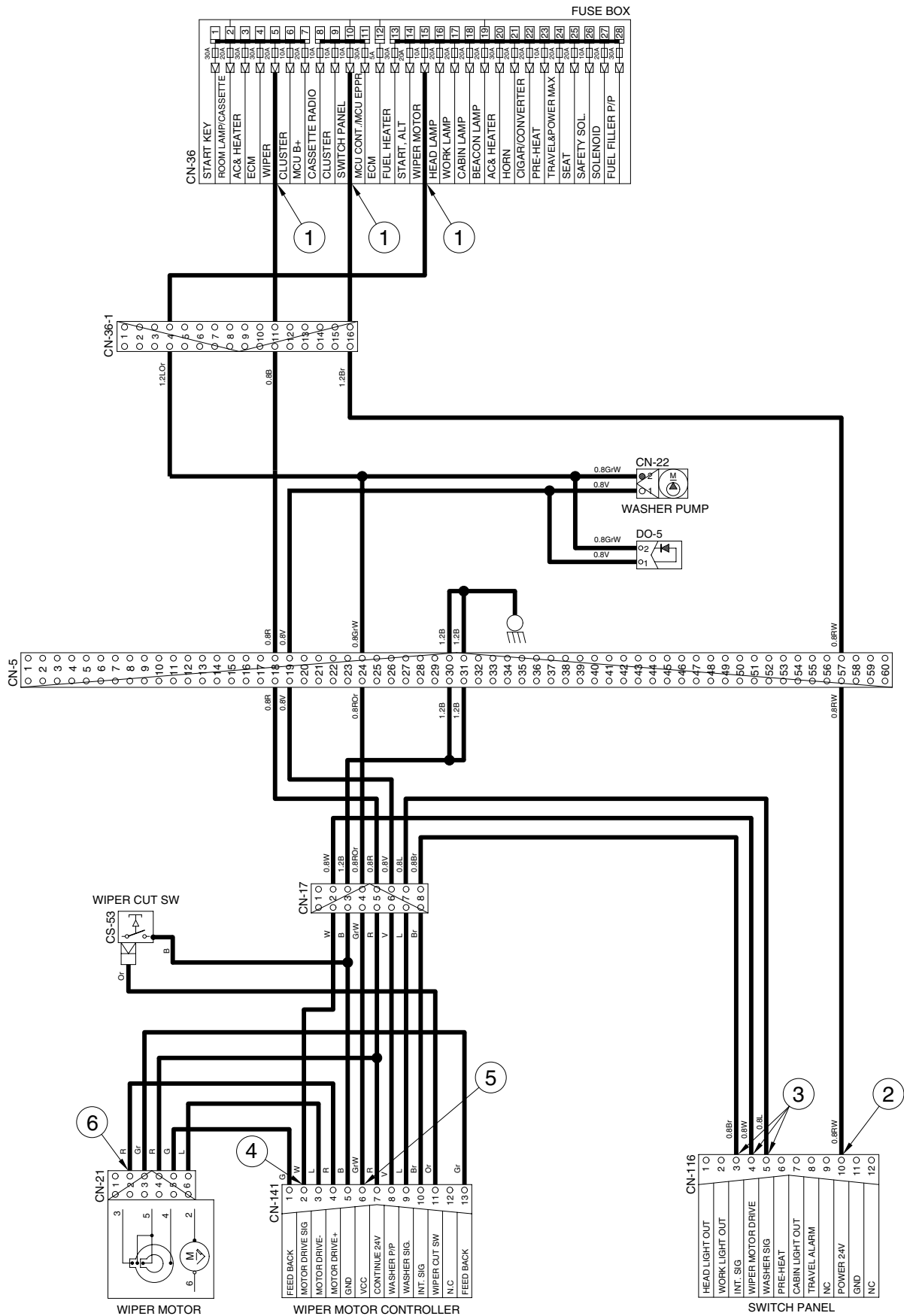

140Z94EL08

MONITORING CIRCUIT

