

GROUP 12 BOOM, ARM, BUCKET, DOZER AND OUTRIGGER CYLINDERS

1. REMOVAL AND INSTALL

1) BUCKET CYLINDER

(1) Removal

- ※ Expand the arm and bucket fully, lower the work equipment to the ground and stop the engine.
- ※ Operate the control levers and pedals several times to release the remaining pressure in the hydraulic piping.
- ※ Loosen the breather slowly to release the pressure inside the hydraulic tank.

▲ Escaping fluid under pressure can penetrate the skin causing serious injury.

- ※ Fit blind plugs in the hoses after disconnecting them, to prevent dirt or dust from entering.

- ① Set block between bucket cylinder and arm.

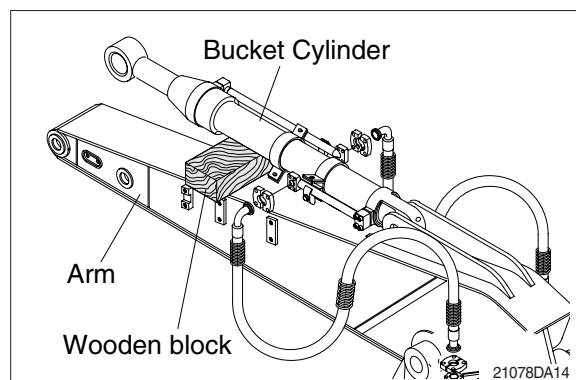

- ② Remove bolt (2), nut (3) and pull out pin (1).

- ※ Tie the rod with wire to prevent it from coming out.

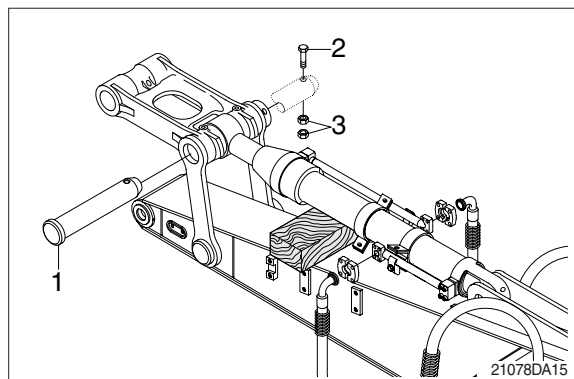

- ③ Disconnect bucket cylinder hoses (4) and put plugs (5) on cylinder pipe.

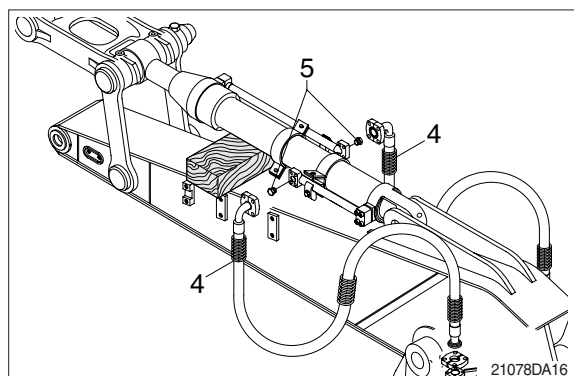

- ④ Sling bucket cylinder assembly (8) and remove bolt (6) then pull out pin (5).
- ⑤ Remove bucket cylinder assembly (8).
 - Weight : 100 kg (220 lb)

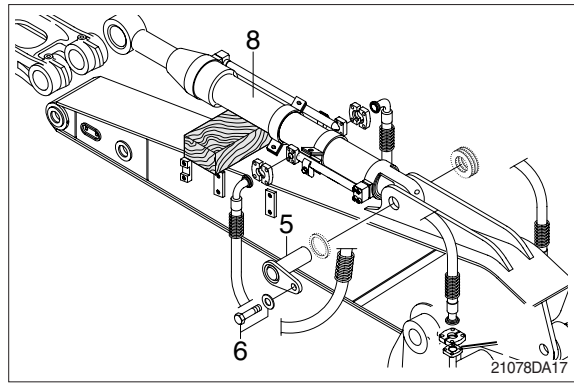

(2) Install

- ① Carry out installation in the reverse order to removal.
- ▲ When aligning the mounting position of the pin, do not insert your fingers in the pin hole.**
- ※ Bleed the air from the bucket cylinder.
 - ※ Confirm the hydraulic oil level and check the hydraulic oil leak or not.

2) ARM CYLINDER

(1) Removal

- ※ Expand the arm and bucket fully, lower the work equipment to the ground and stop the engine.
- ※ Operate the control levers and pedals several times to release the remaining pressure in the hydraulic piping.
- ※ Loosen the breather slowly to release the pressure inside the hydraulic tank.

▲ Escaping fluid under pressure can penetrate the skin causing serious injury. Fit blind plugs in the hoses after disconnecting them, to prevent dirt or dust from entering.

- ① Set block between arm cylinder and boom.

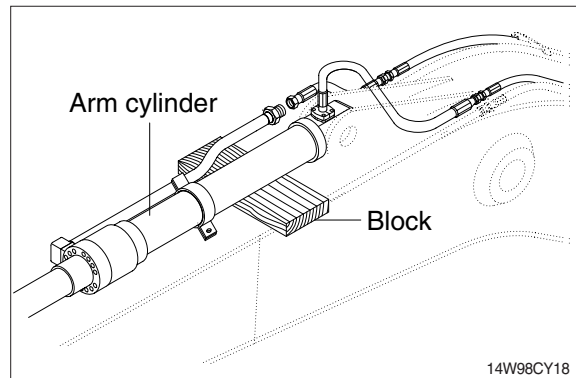

- ② Remove bolt (2) and pull out pin (1).

- ※ Tie the rod with wire to prevent it from coming out.

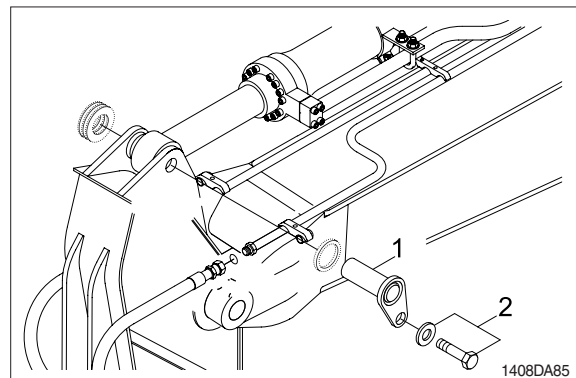

- ③ Disconnect arm cylinder hoses (4) and put plugs on cylinder pipe.

- ④ Disconnect greasing pipings (5).

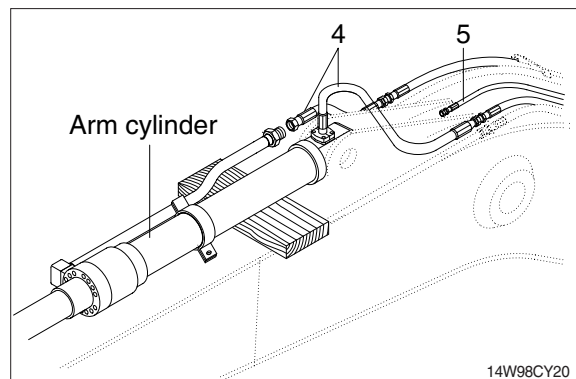

- ⑤ Sling arm cylinder assembly(8) and remove bolt (7) then pull out pin (6).
- ⑥ Remove arm cylinder assembly (8).
 - Weight : 160 kg (350 lb)

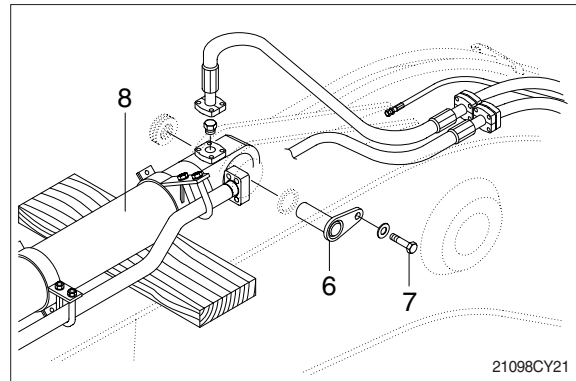

(2) Install

- ① Carry out installation in the reverse order to removal.
- ▲ When aligning the mounting position of the pin, do not insert your fingers in the pin hole.**
- ※ Bleed the air from the arm cylinder.
 - ※ Confirm the hydraulic oil level and check the hydraulic oil leak or not.

3) BOOM CYLINDER

(1) Removal

- ※ Expand the arm and bucket fully, lower the work equipment to the ground and stop the engine.
- ※ Operate the control levers and pedals several times to release the remaining pressure in the hydraulic piping.
- ※ Loosen the breather slowly to release the pressure inside the hydraulic tank.

▲ Escaping fluid under pressure can penetrate the skin causing serious injury.

- ※ Fit blind plugs in the hoses after disconnecting them, to prevent dirt or dust from entering.
- ① Disconnect greasing hoses (1).
 - ② Sling boom cylinder assembly.

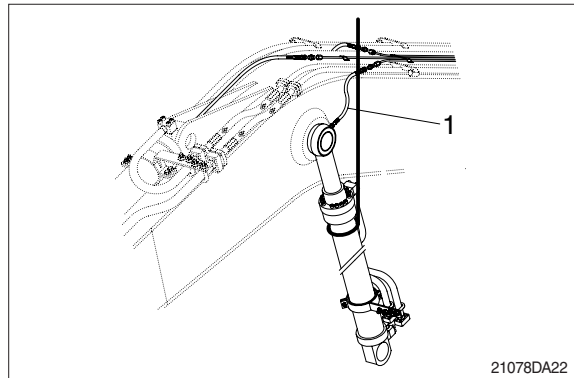

- ③ Remove bolt (4), stopper (5) and pull out pin (2).
- ※ Tie the rod with wire to prevent it from coming out.

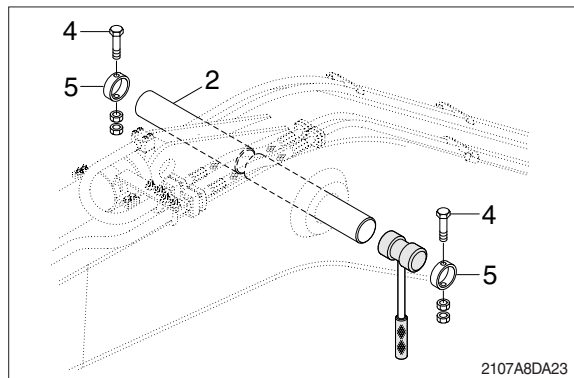

- ④ Lower the boom cylinder assembly (6) on a stand.

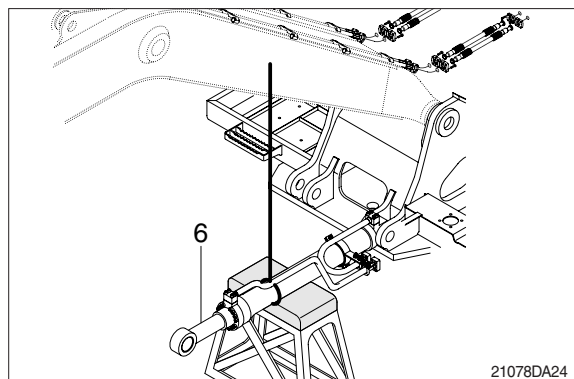

- ⑤ Disconnect boom cylinder hoses (7) and put plugs on cylinder pipe.

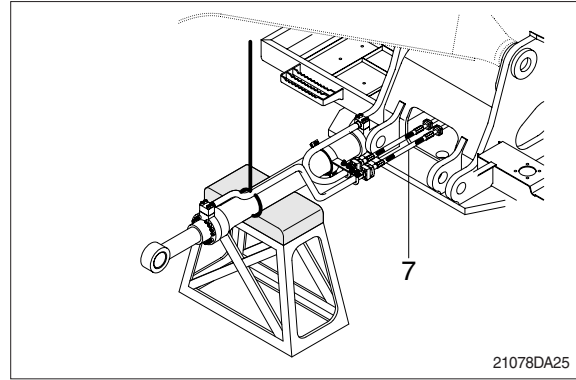

- ⑥ Remove bolt (9) and pull out pin (8).
⑦ Remove boom cylinder assembly (6).
· Weight : 130 kg (285 lb)

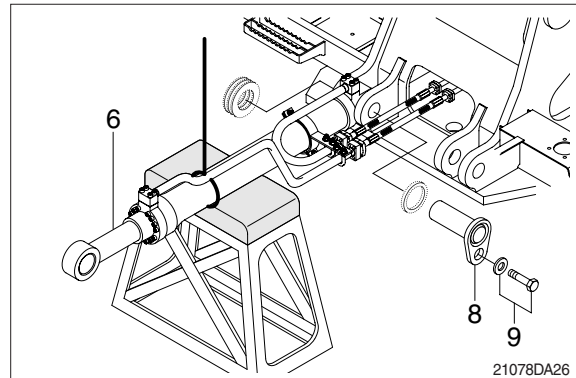

(2) Install

- ① Carry out installation in the reverse order to removal.
- ▲ **When aligning the mounting position of the pin, do not insert your fingers in the pin hole.**
- ※ Bleed the air from the boom cylinder.
 - ※ Confirmed the hydraulic oil level and check the hydraulic oil leak or not.

4) DOZER CYLINDER

(1) Removal

- ※ Expand the arm and bucket fully, lower the work equipment to the ground and stop the engine.
- ※ Operate the control levers and pedals several times to release the remaining pressure in the hydraulic piping.
- ※ Loosen the breather slowly to release the pressure inside the hydraulic tank.

▲ Escaping fluid under pressure can penetrate the skin causing serious injury.

- ※ Fit blind plugs in the hoses after disconnecting them, to prevent dirt or dust from entering.

① Lower the dozer blade to the ground.

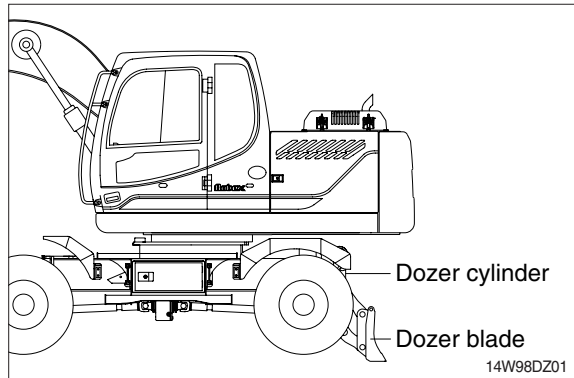

② Disconnect dozer cylinder hoses (1), and put plugs on cylinder pipe.

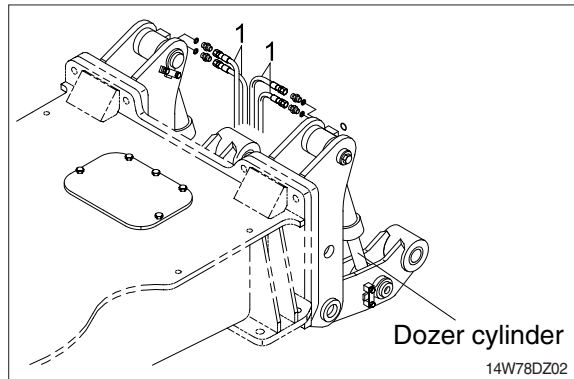

③ Sling dozer cylinder assembly.

④ Remove bolt (2) and pull out pin (3).

- ※ Tie the rod with wire to prevent it from coming out.

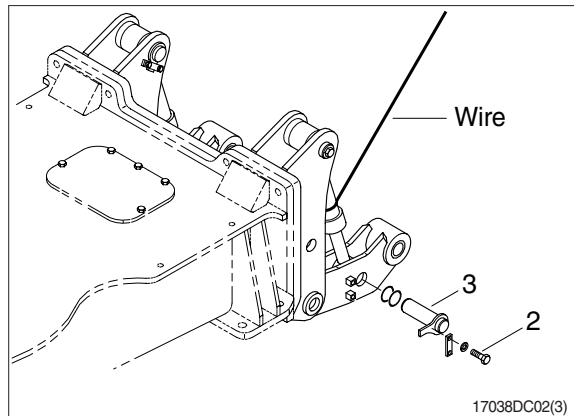

- ⑤ Lower the dozer cylinder rod side on a wooden block.

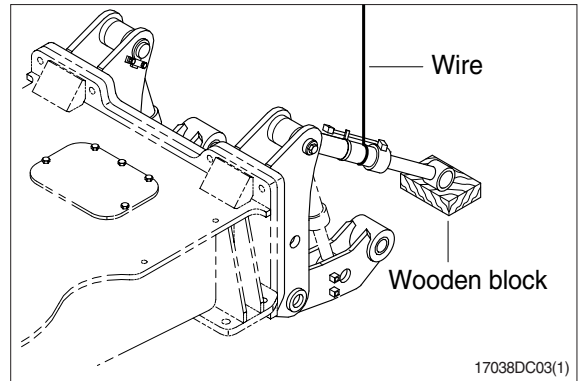

- ⑥ Loosen the bolt (4) and remove lock washer (5), hook plate (6), and spacer (7). Remove bolt (8) and pull out pin (9).
⑦ Remove the dozer cylinder assy (10).
⑧ · Weight : 55 kg (120 lb)

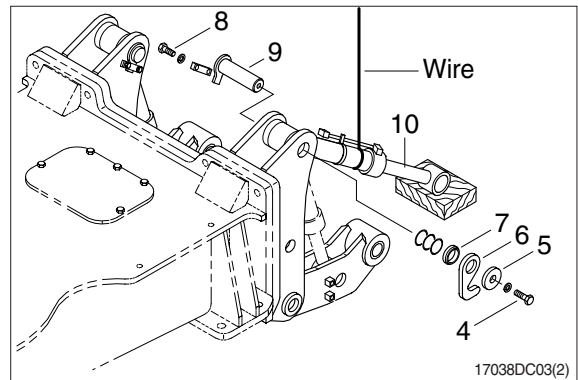

(2) Install

- ① Carry out installation in the reverse order to removal.
- ▲ When aligning the mounting position of the pin, do not insert your fingers in the pin hole.**
- ※ Bleed the air from the dozer cylinder.
 - ※ Confirm the hydraulic oil level and check the hydraulic oil leak or not.

2. DISASSEMBLY AND ASSEMBLY

1) STRUCTURE

(1) Bucket cylinder

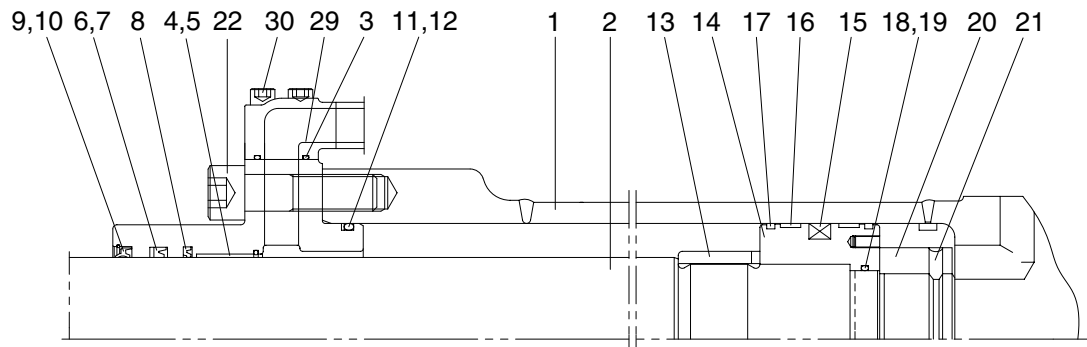

Internal detail

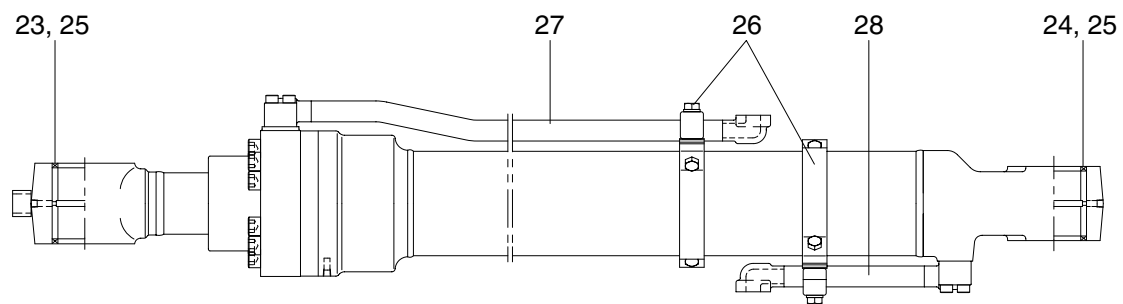

14W98CY01

1	Tube assembly	11	O-ring	21	Hexagon socket set screw
2	Rod assembly	12	Back up ring	22	Hexagon socket head bolt
3	Gland	13	Cushion ring	23	Pin bushing
4	DD2 bushing	14	Piston	24	Pin bushing
5	Snap ring	15	Piston seal	25	Dust seal
6	Rod seal	16	Wear ring	26	Band assembly
7	Back up ring	17	Dust ring	27	Pipe assembly-R
8	Buffer ring	18	O-ring	28	Pipe assembly-B
9	Dust wiper	19	Back up ring	29	O-ring
10	Snap ring	20	Lock nut	30	Hexagon socket head bolt

(2) Arm cylinder

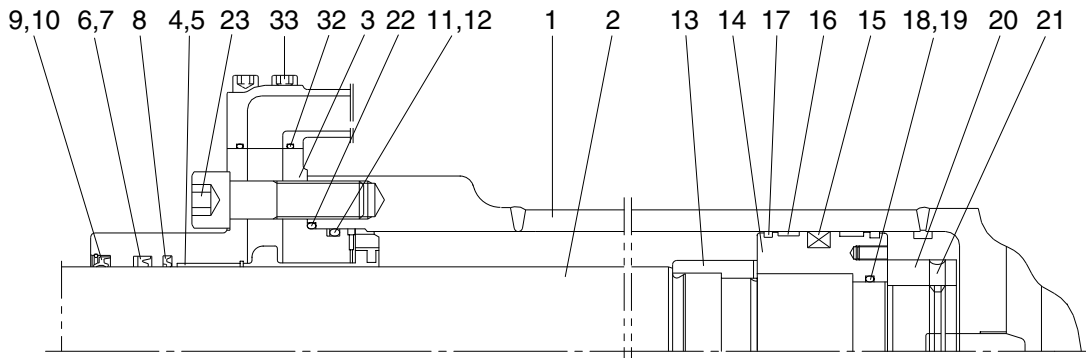

Internal detail

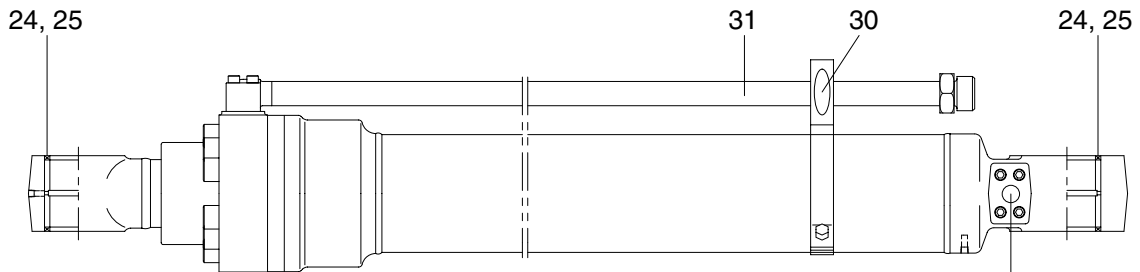

25,26,27,28

14W98CY02

- | | | | | | |
|----|---------------|----|--------------------------|----|--------------------------|
| 1 | Tube assembly | 12 | Back up ring | 23 | Hexagon socket head bolt |
| 2 | Rod assembly | 13 | Cushion ring | 24 | Pin bushing |
| 3 | Gland | 14 | Piston | 25 | Dust seal |
| 4 | DD2 bushing | 15 | Piston seal | 26 | Check valve |
| 5 | Snap ring | 16 | Wear ring | 27 | Coil spring |
| 6 | Rod seal | 17 | Dust ring | 28 | O-ring |
| 7 | Back up ring | 18 | O-ring | 29 | Plug |
| 8 | Buffer ring | 19 | Back up ring | 30 | Band assembly |
| 9 | Dust wiper | 20 | Lock nut | 31 | Pipe assembly-R |
| 10 | Snap ring | 21 | Hexagon socket set screw | 32 | O-ring |
| 11 | O-ring | 22 | O-ring | 33 | Hexagon socket head bolt |

(3) Boom cylinder

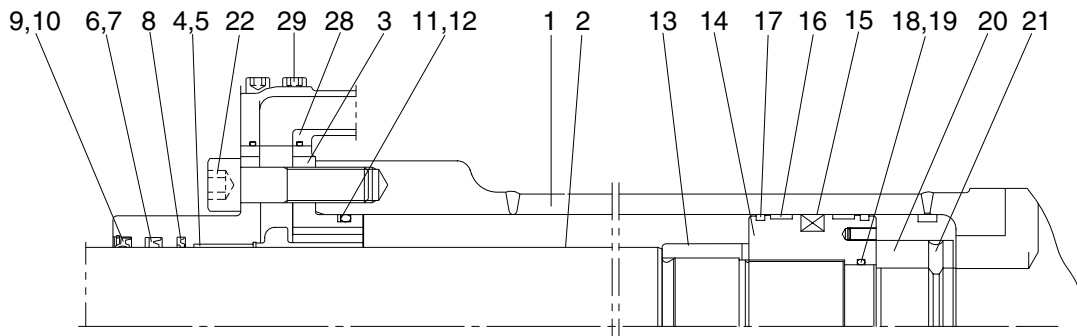

Internal detail

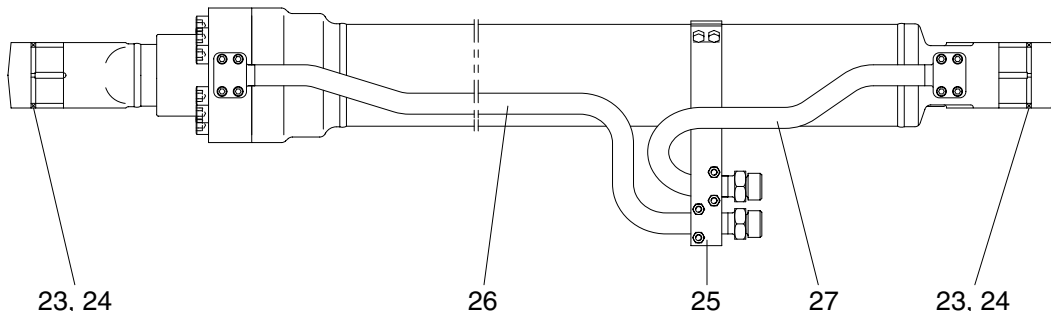

14W98CY03

- | | | | | | |
|----|---------------|----|--------------|----|--------------------------|
| 1 | Tube assembly | 11 | O-ring | 21 | Hexagon socket set screw |
| 2 | Rod assembly | 12 | Back up ring | 22 | Hexagon socket head bolt |
| 3 | Gland | 13 | Cushion ring | 23 | Pin bushing |
| 4 | DD2 bushing | 14 | Piston | 24 | Dust seal |
| 5 | Snap ring | 15 | Piston seal | 25 | Band assembly |
| 6 | Rod seal | 16 | Wear ring | 26 | Pipe assembly-R |
| 7 | Back up ring | 17 | Dust ring | 27 | Pipe assembly-B |
| 8 | Buffer ring | 18 | O-ring | 28 | O-ring |
| 9 | Dust wiper | 19 | Back up ring | 29 | Hexagon socket head bolt |
| 10 | Snap ring | 20 | Lock nut | | |

(4) Dozer cylinder

① Rear dozer cylinder

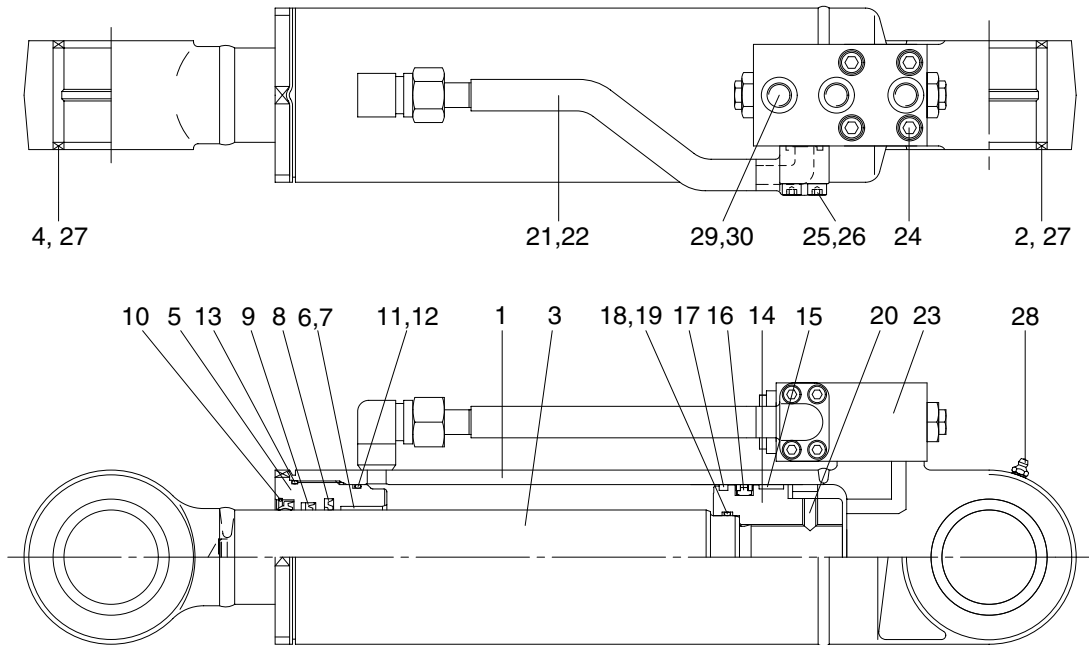

14W98CY04

- | | | | | | |
|----|----------------|----|---------------|----|--------------------------|
| 1 | Tube assembly | 12 | Back up ring | 22 | O-ring |
| 2 | Pin bushing | 13 | O-ring | 23 | Check valve assembly |
| 3 | Rod assembly | 14 | Piston | 24 | Hexagon socket head bolt |
| 4 | Pin bushing | 15 | Wear ring | 25 | Hexagon socket head bolt |
| 5 | Rod cover | 16 | Piston seal | 26 | Spring washer |
| 6 | Rod bushing | 17 | Dust ring | 27 | Wiper pin |
| 7 | Retaining ring | 18 | O-ring | 28 | Grease nipple |
| 8 | Buffer ring | 19 | Back up ring | 29 | Plug |
| 10 | Dust wiper | 20 | Set screw | 30 | O-ring |
| 11 | O-ring | 21 | Pipe assembly | | |

② Front dozer cylinder

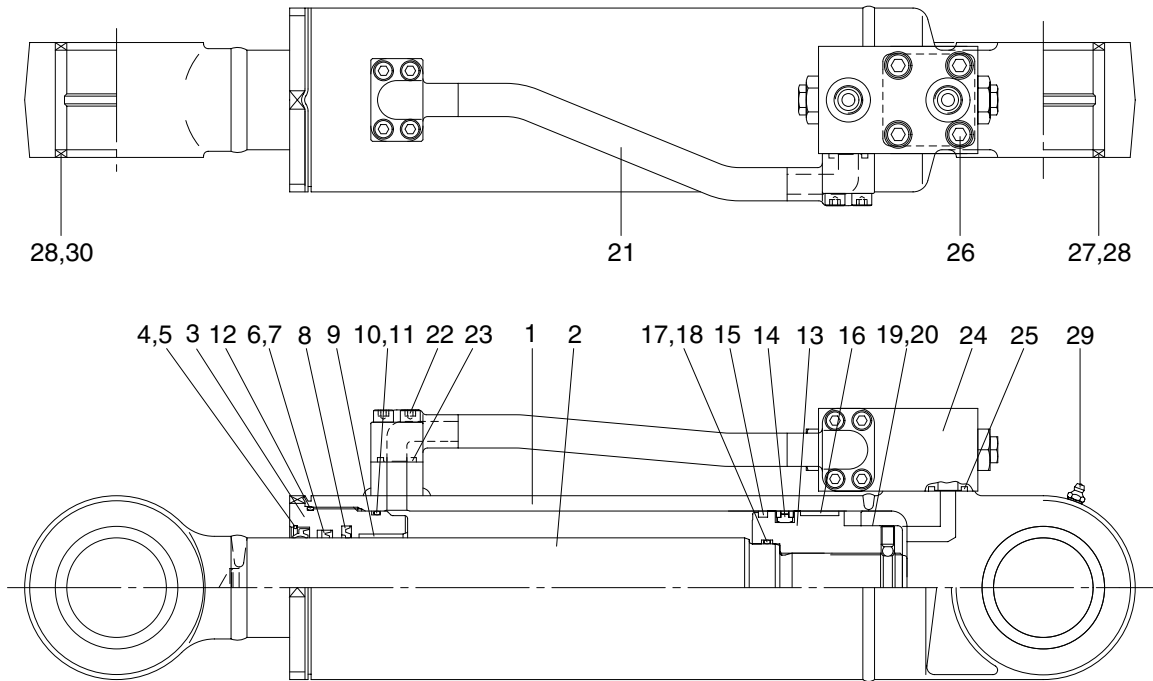

14W98CY05

1	Tube assembly	11	Back up ring	21	Pipe assembly
2	Rod assembly	12	O-ring	22	Hexagon socket head bolt
3	Gland	13	Piston	23	O-ring
4	Dust wiper	14	Piston seal	24	Check valve assembly
5	Retainer ring	15	Dust ring	25	O-ring
6	Rod seal	16	Wear ring	26	Hexagon socket head bolt
7	Back up ring	17	O-ring	27	Pin bushing
8	Buffer ring	18	Back up ring	28	Dust seal
9	DD2 bushing	19	Steel ball	29	Grease nipple
10	O-ring	20	Set screw	30	Pin bushing

(5) Outrigger cylinder

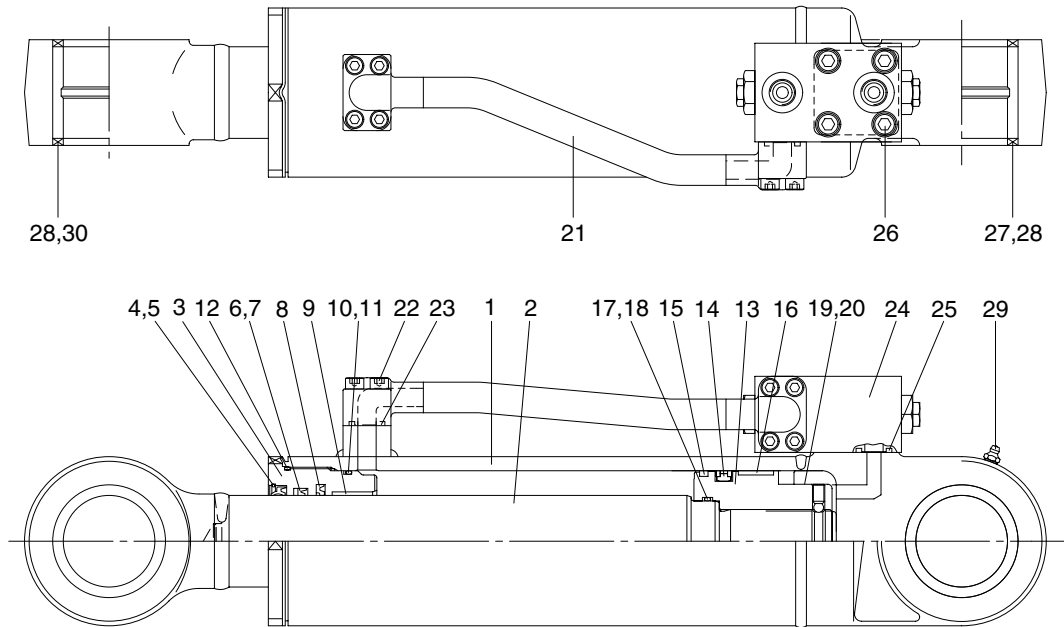

14W98CY06

1	Tube assembly	11	Back up ring	21	Pipe assembly
2	Rod assembly	12	O-ring	22	Hexagon socket head bolt
3	Gland	13	Piston	23	O-ring
4	Dust wiper	14	Piston seal	24	Check valve assembly
5	Retainer ring	15	Dust ring	25	O-ring
6	Rod seal	16	Wear ring	26	Hexagon socket head bolt
7	Back up ring	17	O-ring	27	Pin bushing
8	Buffer ring	18	Back up ring	28	Pin bushing
9	Du bushing	19	Steel ball	29	Dust seal
10	O-ring	20	Set screw		

2) TOOLS AND TIGHTENING TORQUE

(1) Tools

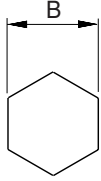
Tool name	Remark		
Allen wrench	6		
	8		
	14		
	17		
Spanner	7		
	8		
(-) Driver	Small and large sizes		
Torque wrench	Capable of tightening with the specified torques		

(2) Tightening torque

Part name	Item	Size	Torque		
			kgf · m	lbf · ft	
Socket head bolt	Bucket cylinder	22	M14	15 ± 2.0	108 ± 14.5
	Boom cylinder		M14	15 ± 2.0	108 ± 14.5
	Arm cylinder	23	M16	23 ± 2.0	166 ± 14.5
	Dozer cylinder	25	M8	2.7 ± 0.3	19.5 ± 2.2
	Outrigger cylinder	22			
	Dozer cylinder	24	M10	5.4 ± 0.5	39.1 ± 3.6
	Outrigger cylinder	26			
Pipe mounting socket head bolt	Bucket	30	M10	5.4 ± 0.5	39.1 ± 3.6
	Boom	29	M8	2.7 ± 0.3	19.6 ± 2.2
	Arm	33	M10	5.4 ± 0.5	39.1 ± 3.6
Lock nut	Bucket cylinder	20	M45	100 ± 10.0	723 ± 72.3
	Boom cylinder		M50		
	Arm cylinder		M55		
Piston	Bucket cylinder	14	-	150 ± 15.0	1085 ± 109
	Boom cylinder				
	Arm cylinder				
	Dozer cylinder - Rear	13		140 ± 14.0	1012 ± 101
	Dozer cylinder - Front				
	Outrigger cylinder				

3) DISASSEMBLY

(1) Remove cylinder head and piston rod

※ Procedures are based on the bucket cylinder.

① Hold the clevis section of the tube in a vise.

※ Use mouth pieces so as not to damage the machined surface of the cylinder tube. Do not make use of the outside piping as a locking means.

② Pull out rod assembly (2) about 200mm (7.1in). Because the rod assembly is rather heavy, finish extending it with air pressure after the oil draining operation.

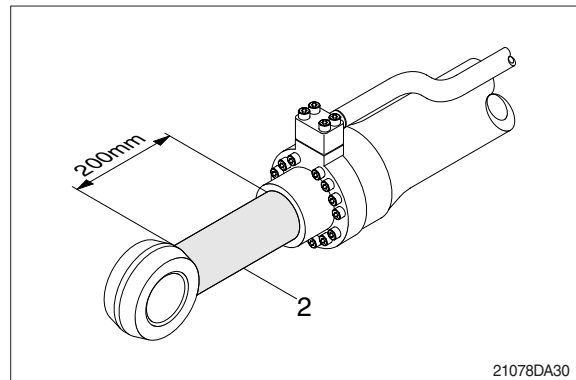

③ Loosen and remove socket bolts (22) of the gland in sequence.

※ Cover the extracted rod assembly (2) with rag to prevent it from being accidentally damaged during operation.

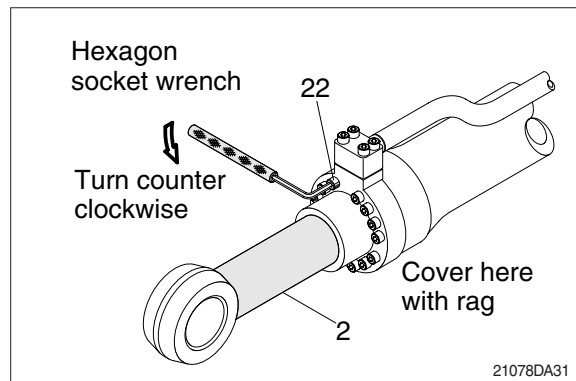

④ Draw out cylinder head and rod assembly together from tube assembly (1).

※ Since the rod assembly is heavy in this case, lift the tip of the rod assembly (2) with a crane or some means and draw it out. However, when rod assembly (2) has been drawn out to approximately two thirds of its length, lift it in its center to draw it completely.

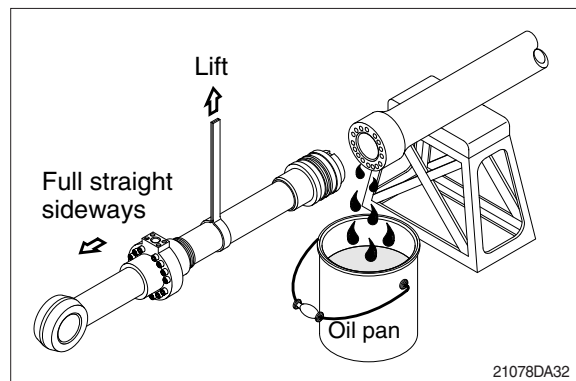

Note that the plated surface of rod assembly (2) is to be lifted. For this reason, do not use a wire sling and others that may damage it, but use a strong cloth belt or a rope.

- ⑤ Place the removed rod assembly on a wooden V-block that is set level.
- ※ Cover a V-block with soft rag.

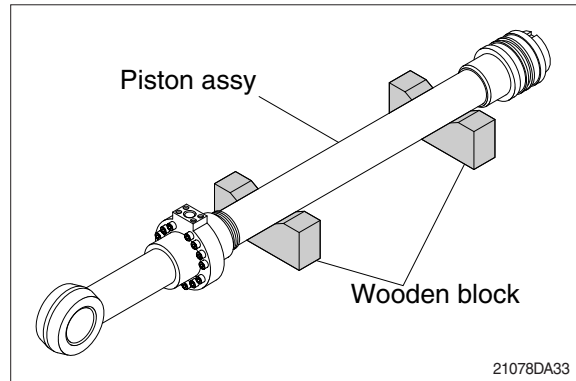

(2) Remove piston and cylinder head

- ① Remove set screw (21).
- ※ Since set screw (21) and lock nut (20) is tightened to a high torque, use a hydraulic and power wrench that utilizes a hydraulic cylinder, to remove the lock set screw (21) and lock nut (20).
- ② Remove piston assembly (14), back up ring (19), and O-ring (18).

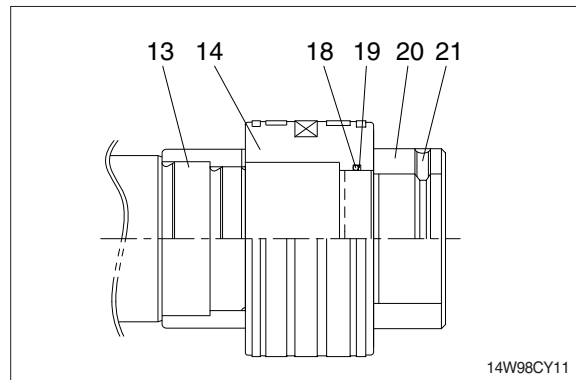

- ③ Remove the cylinder head assembly from rod assembly (2).
- ※ If it is too heavy to move, move it by striking the flanged part of cylinder head with a plastic hammer.
- ※ Pull it straight with cylinder head assembly lifted with a crane. Exercise care so as not to damage the lip of rod bushing (4) and packing (5,6,7,8,9,10) by the threads of rod assembly (2).

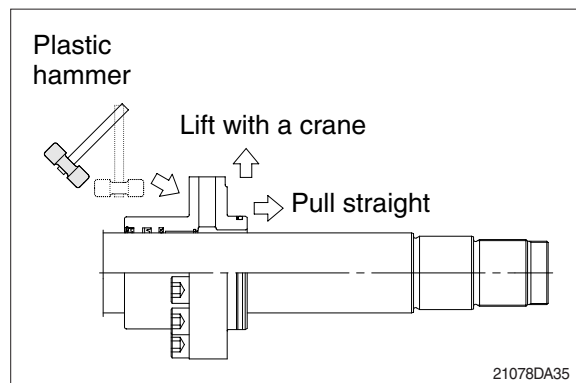

(3) Disassemble the piston assembly

- ① Remove wear ring (16).
 - ② Remove dust ring (17) and piston seal (15).
- ※ Exercise care in this operation not to damage the grooves.

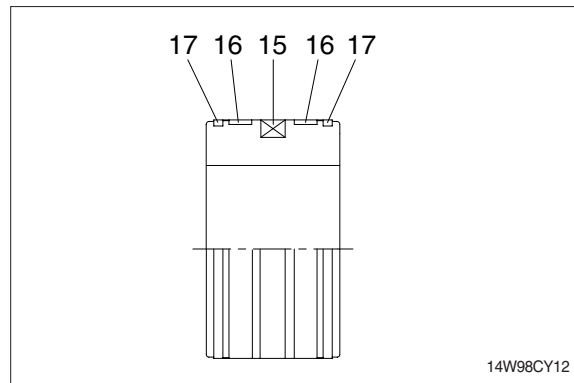

(4) Disassemble cylinder head assembly

- ① Remove back up ring (12) and O-ring (11).
 - ② Remove snap ring (10), dust wiper (9).
 - ③ Remove back up ring (7), rod seal (6) and buffer ring (8).
- ※ Exercise care in this operation not to damage the grooves.
- ※ Do not remove seal and ring, if does not damaged.
- ※ Do not remove bushing (4).

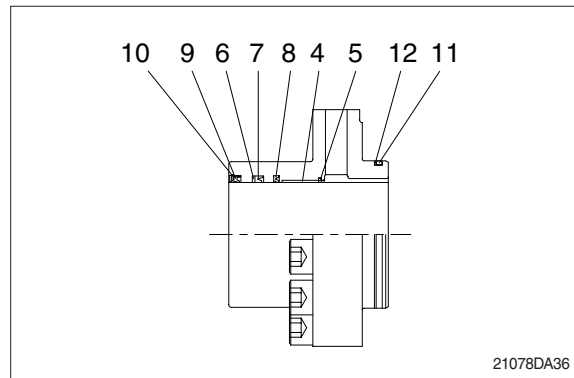

3) ASSEMBLY

(1) Assemble cylinder head assembly

※ Check for scratches or rough surfaces if found smooth with an oil stone.

- ① Coat the inner face of gland (3) with hydraulic oil.

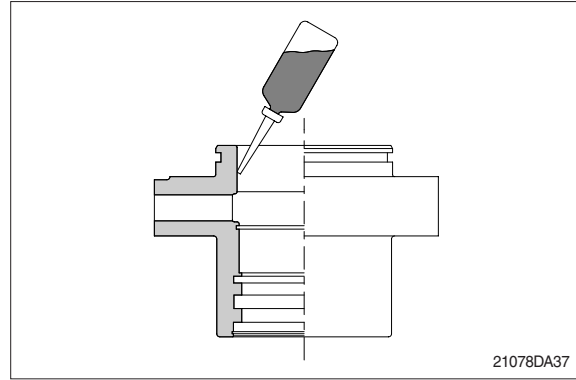

- ② Coat dust wiper (9) with grease and fit dust wiper (9) to the bottom of the hole of dust seal.

At this time, press a pad metal to the metal ring of dust seal.

- ③ Fit snap ring (10) to the stop face.

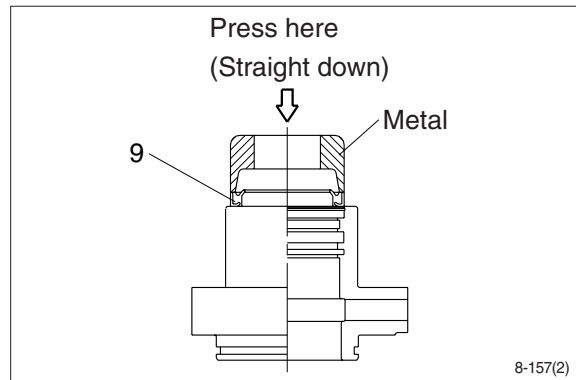

- ④ Fit back up ring (7), rod seal (6) and buffer ring (8) to corresponding grooves, in that order.

※ Coat each packing with hydraulic oil before fitting it.

※ Insert the backup ring until one side of it is inserted into groove.

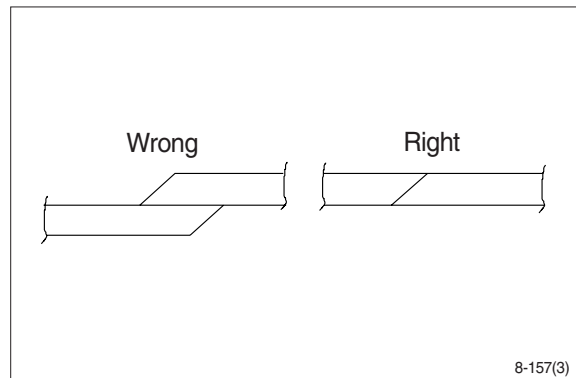

※ Rod seal (6) has its own fitting direction. Therefore, confirm it before fitting them.

※ Fitting rod seal (6) upside down may damage its lip. Therefore check the correct direction that is shown in fig.

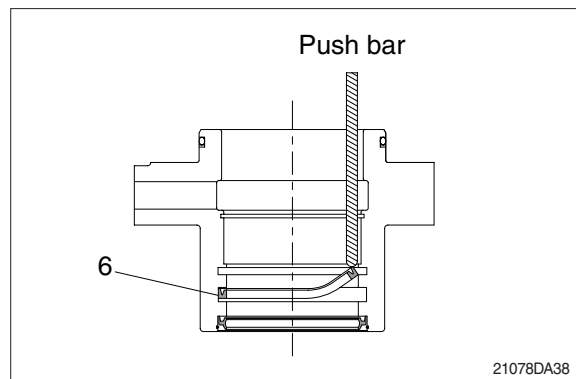

- ⑤ Fit back up ring (12) to gland (3).
- ※ Put the backup ring in the warm water of 30~50°C.
- ⑥ Fit O-ring (11) to gland (3).

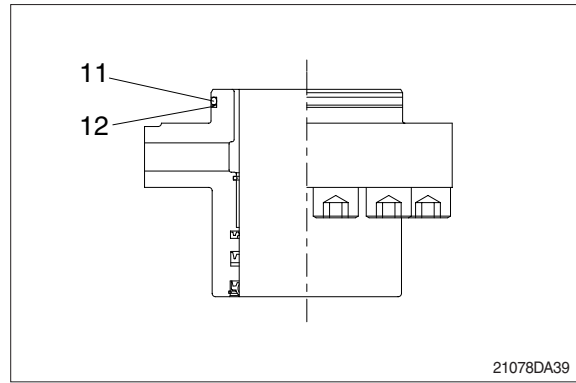

(2) Assemble piston assembly

- ※ Check for scratches or rough surfaces. If found smooth with an oil stone.
- ① Coat the outer face of piston (14) with hydraulic oil.

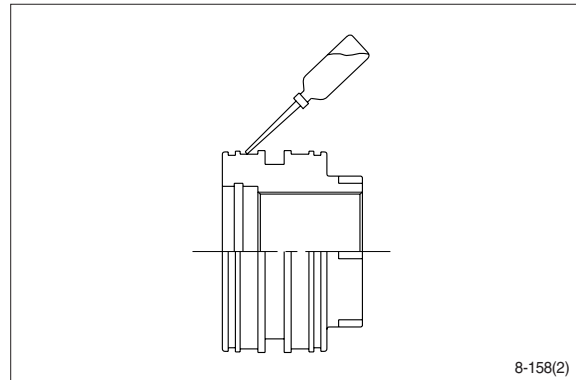

- ② Fit piston seal (15) to piston.
- ※ Put the piston seal in the warm water of 60~100°C for more than 5 minutes.
- ※ After assembling the piston seal, press its outer diameter to fit in.

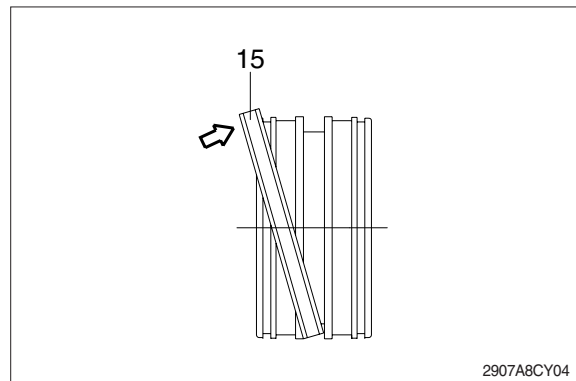

- ③ Fit wear ring (16) and dust ring (17) to piston (14).

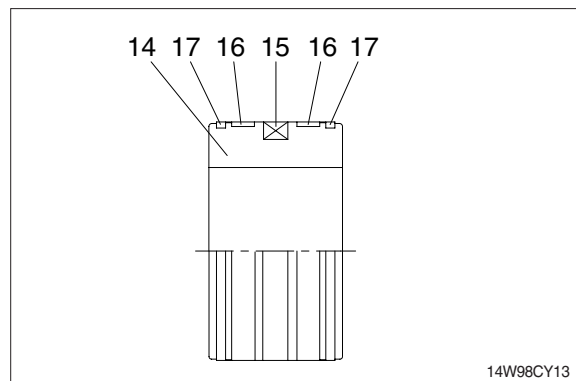

(3) Install piston and cylinder head

- ① Fix the rod assembly to the work bench.
- ② Apply hydraulic oil to the outer surface of rod assembly (2), the inner surface of piston and cylinder head.
- ③ Insert cylinder head assembly to rod assembly.

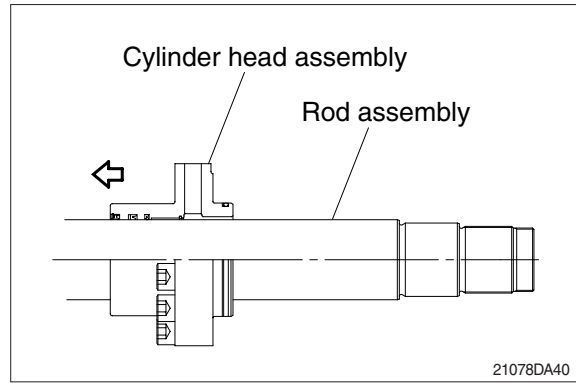

- ④ Insert cushion ring (13) to rod assembly.
- ※ Note that cushion ring (13) has a direction in which it should be fitted.

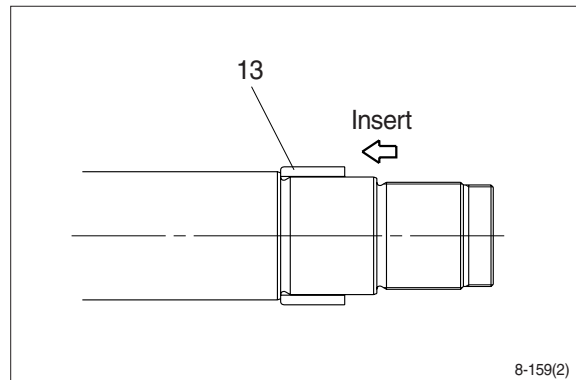

- ⑤ Fit piston assembly to rod assembly.
- Tightening torque : $150 \pm 15 \text{ kgf} \cdot \text{m}$
($1085 \pm 108 \text{ lbf} \cdot \text{ft}$)

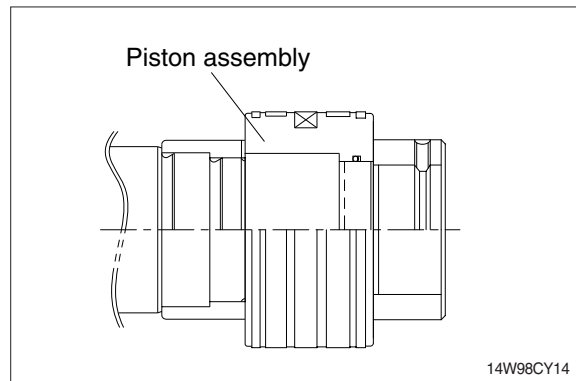

- ⑥ Fit lock nut (20) and tighten the screw (21).
- Tightening torque :

Item		kgf · m	lbf · ft
20	Bucket	100 ± 10	723 ± 72.3
	Boom		
	Arm		
21		2.7 ± 0.3	19.6 ± 2.2

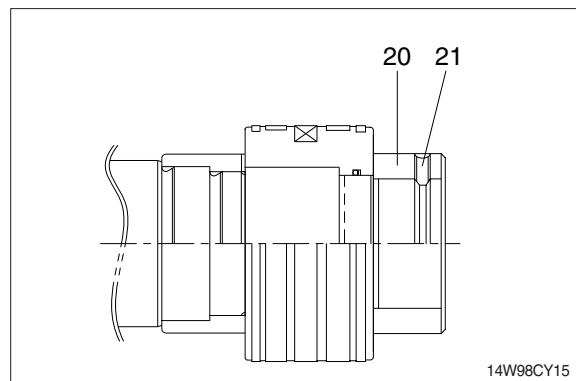

(3) Overall assemble

- ① Place a V-block on a rigid work bench.
Mount the tube assembly (1) on it and fix the assembly by passing a bar through the clevis pin hole to lock the assembly.
- ② Insert the rod assembly in to the tube assembly, while lifting and moving the rod assembly with a crane.
 - ※ Be careful not to damage piston seal by thread of tube assembly.
- ③ Match the bolt holes in the cylinder head flange to the tapped holes in the tube assembly and tighten socket bolts to a specified torque.
 - ※ Refer to the table of tightening torque.

