

GROUP 3 WORK EQUIPMENT

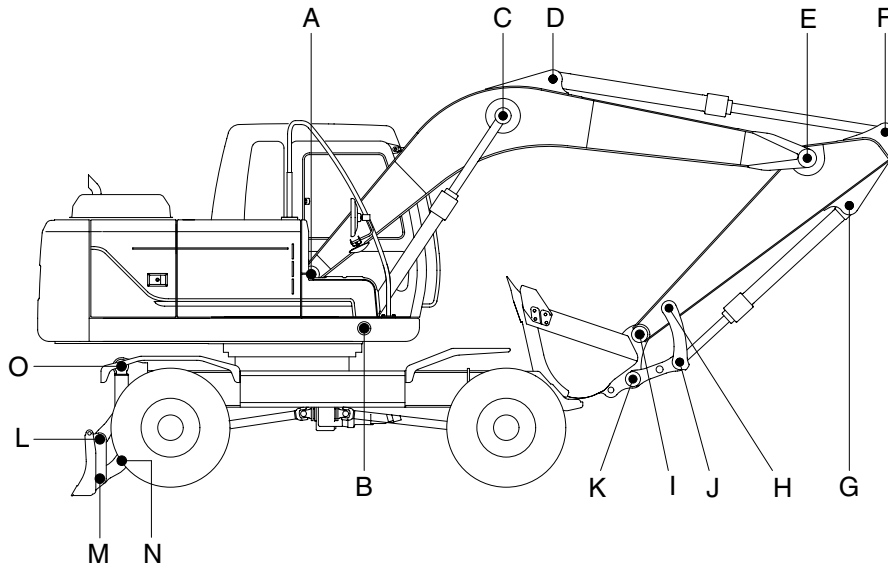

14W97MS20

Unit : mm

Mark	Measuring point (pin and bushing)	Normal value	Pin		Bushing		Remedy & Remark
			Recomm. service limit	Limit of use	Recomm. service limit	Limit of use	
A	Boom rear	70	69	68.5	70.5	71	Replace
B	Boom cylinder head	70	69	68.5	70.5	71	"
C	Boom cylinder rod	70	69	68.5	70.5	71	"
D	Arm cylinder head	70	69	68.5	70.5	71	"
E	Boom front	70	69	68.5	70.5	71	"
F	Arm cylinder rod	70	69	68.5	70.5	71	"
G	Bucket cylinder head	70	69	68.5	70.5	71	"
H	Arm link	65	64	63.5	65.5	66	"
I	Bucket and arm link	65	64	63.5	65.5	66	"
J	Bucket cylinder rod	70	69	68.5	70.5	71	"
K	Bucket link	65	64	63.5	65.5	66	"
L	Dozer link (B)	55	54	53.5	55.5	56	"
M	Dozer link (A)	55	54	53.5	55.5	56	"
N	Dozer cylinder rod	65	64	63.5	65.5	66	"
O	Dozer cylinder head	65	64	63.5	65.5	66	"