

# SECTION 7 MAINTENANCE STANDARD

Group 1 Operational Performance Test .....	7-1
Group 2 Major Components .....	7-19
Group 3 Work Equipment .....	7-28

# SECTION 7 MAINTENANCE STANDARD

## GROUP 1 OPERATIONAL PERFORMANCE TEST

### 1. PURPOSE

Performance tests are used to check:

#### 1) OPERATIONAL PERFORMANCE OF A NEW MACHINE

Whenever a new machine is delivered in parts and reassembled at a customer's site, it must be tested to confirm that the operational performance of the machine meets Hyundai spec.

#### 2) OPERATIONAL PERFORMANCE OF A WORKING MACHINE

With the passage of time, the machine's operational performance deteriorates, so that the machine needs to be serviced periodically to restore it to its original performance level.

Before servicing the machine, conduct performance tests to check the extent of deterioration, and to decide what kind of service needs to be done (by referring to the "Service Limits" in this manual).

#### 3) OPERATIONAL PERFORMANCE OF A REPAIRED MACHINE

After the machine is repaired or serviced, it must be tested to confirm that its operational performance was restored by the repair and/or service work done.

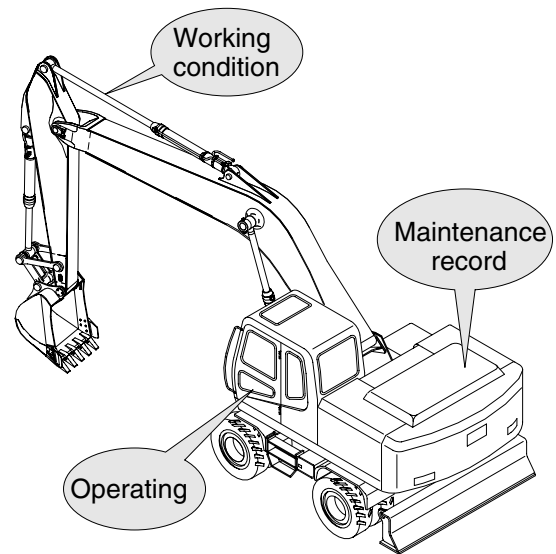

14W77MS01

## 2. TERMINOLOGY

### 1) STANDARD

Specifications applied to the brand-new machine, components and parts.

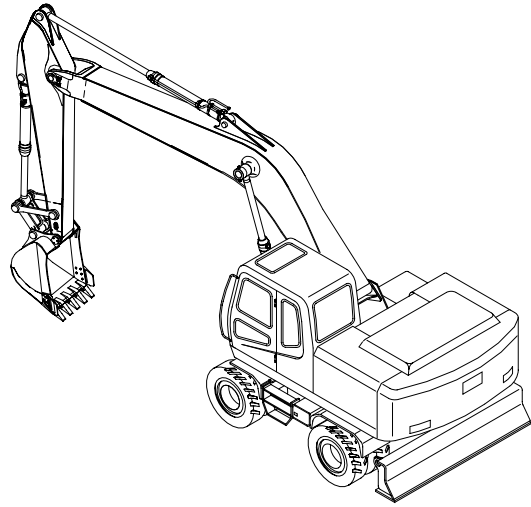

140W77MS02

### 2) SERVICE LIMIT

The lowest acceptable performance level. When the performance level of the machine falls below this level, the machine must be removed from work and repaired. Necessary parts and components must be replaced.

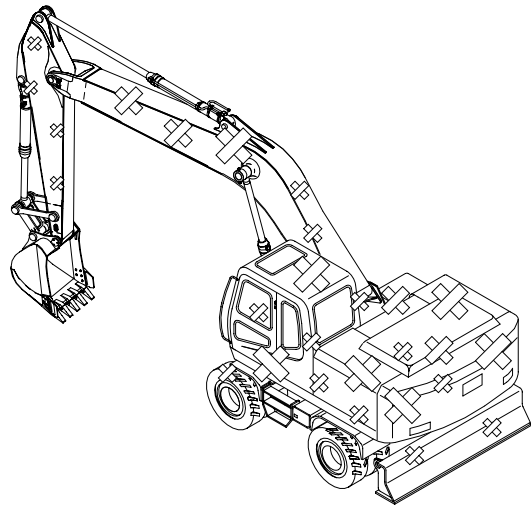

140W77MS03

### 3. OPERATION FOR PERFORMANCE TESTS

- 1) Observe the following rules in order to carry out performance tests accurately and safely.

#### The machine

- (1) Repair any defects and damage found, such as oil or water leaks, loose bolts, cracks and so on, before starting to test.

#### (2) Test area

- ① Select a hard, flat surface.
- ② Secure enough space to allow the machine to run straight more than 20m, and to make a full swing with the front attachment extended.
- ③ If required, rope off the test area and provide signboards to keep unauthorized personnel away.

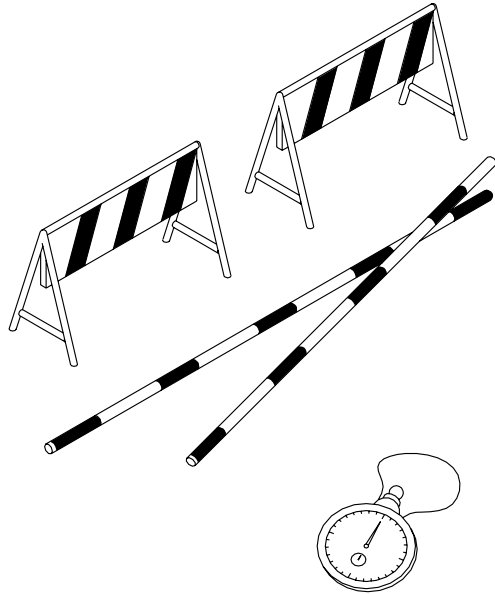

#### (3) Precautions

- ① Before starting to test, agree upon the signals to be employed for communication among coworkers. Once the test is started, be sure to communicate with each other using these signals, and to follow them without fail.
- ② Operate the machine carefully and always give first priority to safety.
- ③ While testing, always take care to avoid accidents due to landslides or contact with high voltage power lines. Always confirm that there is sufficient space for full swings.
- ④ Avoid polluting the machine and the ground with leaking oil. Use oil pans to catch escaping oil. Pay special attention to this when removing hydraulic pipings.

(290-7TIER) 7-3

#### (4) Make precise measurements

- ① Accurately calibrate test instruments in advance to obtain correct data.
- ② Carry out tests under the exact test conditions prescribed for each test item.
- ③ Repeat the same test and confirm that the test data obtained can be procured repeatedly. Use mean values of measurements if necessary.

## 2) ENGINE SPEED

(1) Measure the engine speed at each power mode

※ The engine speed at each power mode must meet standard RPM; if not, all other operational performance data will be unreliable. It is essential to perform this test first.

### (2) Preparation

- ① Warm up the machine, until the engine coolant temperature reaches 50°C or more, and the hydraulic oil is 50±5°C.
- ② Set the accel dial at 10 (Max) position.
- ③ Measure the engine RPM.

### (3) Measurement

- ① Start the engine. The engine will run at start idle speed. Measure engine speed with a engine rpm display.
- ② Measure and record the engine speed at each mode (P, S, E).
- ③ Select the P-mode.
- ④ Lightly operate the bucket control lever a few times, then return the control lever to neutral; The engine will automatically enter the auto-idle speed after 4 seconds.
- ⑤ Measure and record the auto deceleration speed.

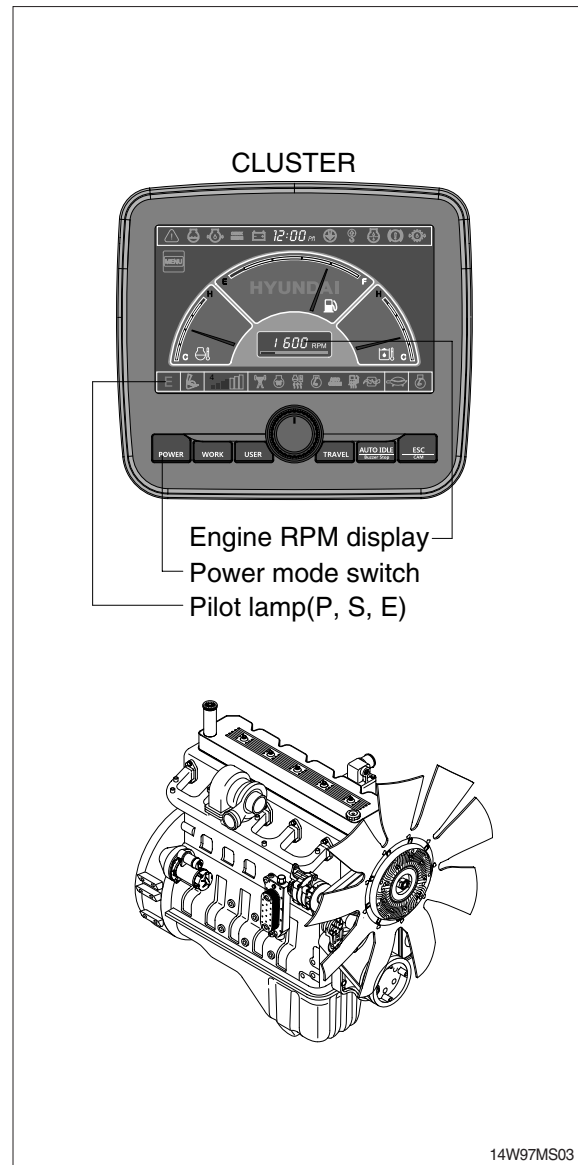

### (4) Evaluation

The measured speeds should meet the following specifications.

Unit : rpm

Model	Engine speed	Standard	Remarks
R140W-9	Start idle	800±100	
	P mode	1500±50	
	S mode	1400±50	
	E mode	1300±50	
	Auto decel	1000±100	
	One touch decel	800±50	

### 3) TRAVEL SPEED

(1) Measure the time require for the excavator to travel a 50m at high speed and a 20m at low speed test run.

#### (2) Preparation

- ① Prepare a flat and solid test track 50m in length, with extra length of 150m for machine acceleration.
- ② Set the traveling position as figure.
- ③ Keep the hydraulic oil temperature at  $50 \pm 5^{\circ}\text{C}$ .

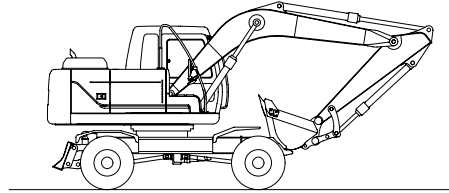

#### (3) Measurement

- ① Measure both the low and high speeds of the machine.
- ② Before starting either the low or high speed tests, adjust the RH multifunction switch to the speed to be tested, then select the following switch position.
  - Power mode switch : P mode
- ③ Start traveling the machine in the extra length with the two speed switch at high or low speed.
- ④ Measure the time required to travel 50 m at high speed or 20m at low speed.
- ⑤ After measuring the Forward travel speed, turn the upperstructure 180° and measure the Reverse travel speed.
- ⑥ Repeat steps ④ and ⑤ three times in each direction and calculate the average values.

14W97MS04

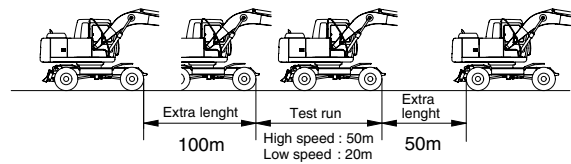

14W97MS05

#### (4) Evaluation

The average measured time should meet the following specifications.

Unit : Seconds

Model	Travel speed	Standard	Maximum allowable	Remarks
R140W-9	Low speed	9	11.3	Seconds / 20 m
	High speed	5.8	7.2	Seconds / 50 m

#### 4) SWING SPEED

(1) Measure the time required to swing three complete turns.

#### (2) Preparation

- ① Check the lubrication of the swing gear and swing bearing.
- ② Place the machine on flat, solid ground with ample space for swinging. Do not conduct this test on slopes.
- ③ With the arm rolled out and bucket rolled in, hold the bucket so that the height of the bucket pin is the same as the boom foot pin. The bucket must be empty.
- ④ Keep the hydraulic oil temperature at  $50 \pm 5^{\circ}\text{C}$ .

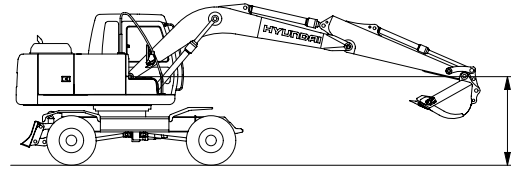

14W96MS06

#### (3) Measurement

- ① Select the following switch positions.
  - Power mode switch : P mode
- ② Operate swing control lever fully.
- ③ Swing 1 turn and measure time taken to swing next 3 revolutions.
- ④ Repeat steps ② and ③ three time and calculate the average values.

#### (4) Evaluation

The time required for 3 swings should meet the following specifications.

Unit : Seconds / 3 revolutions

Model	Power mode switch	Standard	Maximum allowable
R140W-9	P mode	$14.13 \pm 1.5$	17.33

## 5) SWING FUNCTION DRIFT CHECK

- (1) Measure the swing drift on the bearing outer circumference when stopping after a 360° full speed swing.

### (2) Preparation

- ① Check the lubrication of the swing gear and swing bearing.
- ② Place the machine on flat, solid ground with ample space for swinging. Do not conduct this test on slopes.
- ③ With the arm rolled out and bucket rolled in, hold the bucket so that the height of the bucket pin is the same as the boom foot pin. The bucket must be empty.
- ④ Make two chalk marks: one on the swing bearing and one directly below it on the track frame.
- ⑤ Swing the upperstructure 360°.
- ⑥ Keep the hydraulic oil temperature at  $50 \pm 5^\circ\text{C}$ .

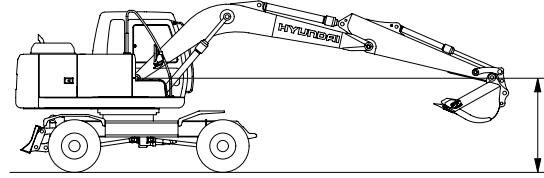

14W97MS06

### (3) Measurement

- ① Conduct this test in the M mode.
- ② Select the following switch positions.
  - Power mode switch : P mode
- ③ Operate the swing control lever fully and return it to the neutral position when the mark on the upperstructure aligns with that on track frame after swinging 360°.
- ④ Measure the distance between the two marks.
- ⑤ Align the marks again, swing 360°, then test the opposite direction.
- ⑥ Repeat steps ④ and ⑤ three times each and calculate the average values.

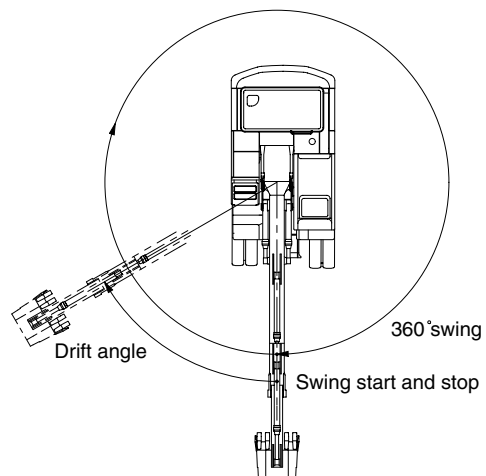

20W77MS04

### (4) Evaluation

The measured drift angle should be within the following specifications.

Unit : Degree

Model	Power mode switch	Standard	Maximum allowable	Remarks
R140W-9	P mode	90 below	157.5	

## 6) SWING BEARING PLAY

(1) Measure the swing bearing play using a dial gauge to check the wear of bearing races and balls.

### (2) Preparation

- ① Check swing bearing mounting cap screws for loosening.
- ② Check the lubrication of the swing bearing. Confirm that bearing rotation is smooth and without noise.
- ③ Install a dial gauge on the track frame as shown, using a magnetic base.
- ④ Position the upperstructure so that the boom aligns with the tracks facing towards the front idlers.
- ⑤ Position the dial gauge so that its needle point comes into contact with the bottom face of the bearing outer race.
- ⑥ Bucket should be empty.

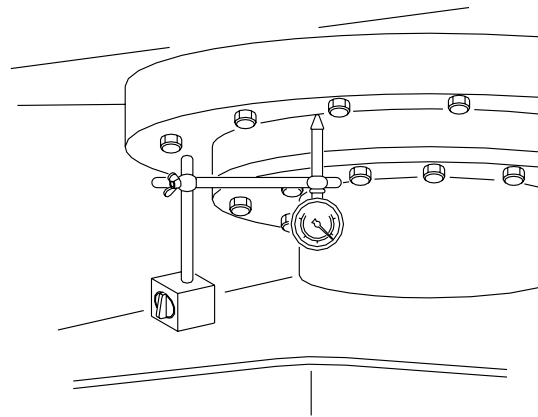

7-10(1) 140-7

### (3) Measurement

- ① With the arm rolled out and bucket rolled in, hold the bottom face of the bucket to the same height of the boom foot pin. Record the dial gauge reading (h1).
- ② Lower the bucket to the ground and use it to raise the front idler 50cm. Record the dial gauge reading (h2).
- ③ Calculate bearing play (H) from this data (h1 and h2) as follows.  
 $H = h2 - h1$

Measurement : (h1)

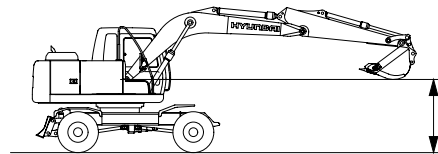

Measurement : (h2)

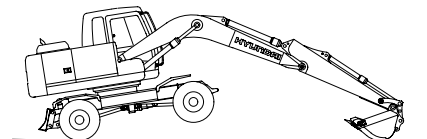

### (4) Evaluation

The measured drift should be within the following specifications.

14W97MS08

Unit : mm

Model	Standard	Maximum allowable	Remarks
R140W-9	0.5 ~ 1.5	3.0	

## 7) HYDRAULIC CYLINDER CYCLE TIME

(1) Measure the cycle time of the boom, standard arm, and standard bucket cylinders.

### (2) Preparation

① To measure the cycle time of the boom cylinders:

With the arm rolled out and the empty bucket rolled out, lower the bucket to the ground, as shown.

② To measure the cycle time of the arm cylinder.

With the empty bucket rolled in, position the arm so that it is vertical to the ground. Lower the boom until the bucket is 0.5 m above the ground.

③ To measure the cycle time of the bucket cylinder.

The empty bucket should be positioned at midstroke between roll-in and roll-out, so that the sideplate edges are vertical to the ground.

④ Keep the hydraulic oil temperature at  $50 \pm 5^\circ\text{C}$ .

### (3) Measurement

① Select the following switch positions.

- Power mode switch : P mode

② To measure cylinder cycle times.

- Boom cylinders.

Measure the time it takes to raise the boom, and the time it takes to lower the boom. To do so, position the boom at one stroke end then move the control lever to the other stroke end as quickly as possible.  
Arm cylinder.

- Measure the time it takes to roll in the arm, and the time it takes to roll out the arm. To do so, position the bucket at one stroke end, then move the control lever to the other stroke end as quickly as possible.

Boom cylinder

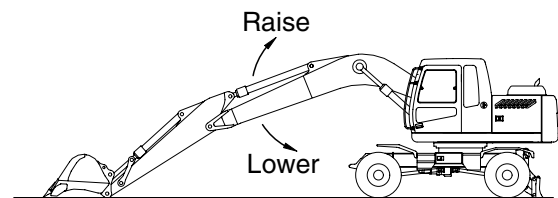

Arm cylinder

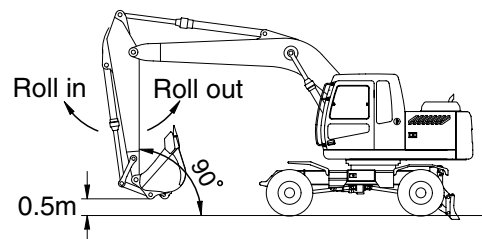

Bucket cylinder

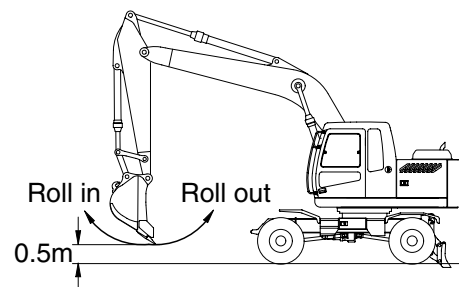

14W97MS09

-Bucket cylinder.

Measure the time it takes to roll in the bucket, and the time it takes to roll out the bucket. To do so, position the bucket at one stroke end, then move the control lever to the other stroke end as quickly as possible.

-Repeat each measurement 3 times and calculate the average values.

**(4) Evaluation**

The average measured time should meet the following specifications.

Unit : Seconds

Model	Function	Standard	Maximum allowable	Remarks	
R140W-9	Boom raise	3.18 ± 0.4	4.0		
	Boom lower	2.7 ± 0.4	3.6		
	Arm in	Regen ON	2.52 ± 0.3	3.4	
		Regen OFF	2.9 ± 0.3	3.4	
	Arm out	2.44 ± 0.3	3.5		
	Bucket load	3.25 ± 0.4	4.0		
	Bucket dump	2.19 ± 0.3	2.6		

## 8) DIG FUNCTION DRIFT CHECK

- (1) Measure dig function drift, which can be caused by oil leakage in the control valve and boom, standard arm, and standard bucket cylinders, with the loaded bucket. When testing the dig function drift just after cylinder replacement, slowly operate each cylinder to its stroke end to purge air.

### (2) Preparation

- ① Load bucket fully. Instead of loading the bucket, weight(W) of the following specification can be used.
  - $W = M^3 \times 1.5$
  - Where :
  - $M^3$  = Bucket heaped capacity ( $m^3$ )
  - 1.5 = Soil specific gravity
- ② Position the arm cylinder with the rod 20 to 30mm extended from the fully retracted position.
- ③ Position the bucket cylinder with the rod 20 to 30mm retracted from the fully extended position.
- ④ With the arm rolled out and bucket rolled in, hold the bucket so that the height of the bucket pin is the same as the boom foot pin.
- ⑤ Keep the hydraulic oil temperature at  $50 \pm 5^\circ C$ .

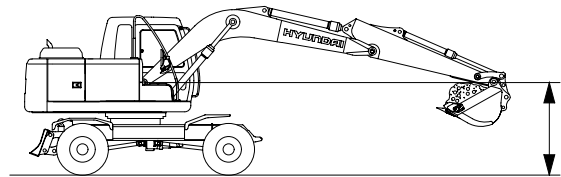

14W97MS10

### (3) Measurement

- ① Stop the engine.
- ② Five minutes after the engine has been stopped, measure the changes in the positions of the boom, arm and bucket cylinders.
- ③ Repeat step ② three times and calculate the average values.

- (4) The measured drift should be within the following specifications.

Unit : mm / 5 min

Model	Drift to be measured	Standard	Maximum allowable	Remarks
R140W-9	Boom cylinder	10 below	20	
	Arm cylinder	10 below	20	
	Bucket cylinder	40 below	60	

## 9) CONTROL LEVER OPERATING FORCE

(1) Use a spring scale to measure the maximum resistance of each control lever at the middle of the grip.

### (2) Preparation

① Keep the hydraulic oil temperature at  $50 \pm 5^\circ\text{C}$ .

### (3) Measurement

- ① Start the engine.
- ② Select the following switch positions.
  - Power mode switch: P mode
- ③ Operate each boom, arm, bucket and swing lever at full stroke and measure the maximum operating force for each.
- ④ Lower the bucket to the ground to raise one track off the ground. Operate the travel lever at full stroke and measure the maximum operating force required. When finished, lower the track and then jack-up the other track.
- ⑤ Repeat steps ③ and ④ three times and calculate the average values.

### (4) Evaluation

The measured operating force should be within the following specifications.

Unit : kgf

Model	Kind of lever	Standard	Maximum allowable	Remarks
R140W-9	Boom lever	1.7 or below	2.0	
	Arm lever	1.7 or below	2.0	
	Bucket lever	1.4 or below	2.0	
	Swing lever	1.4 or below	2.0	

## 10) CONTROL LEVER STROKE

(1) Measure each lever stroke at the lever top using a ruler.

※ When the lever has play, take a half of this value and add it to the measured stroke.

### (2) Preparation

Keep the hydraulic oil temperature at  $50 \pm 5^{\circ}\text{C}$ .

### (3) Measurement

① Stop the engine.

② Measure each lever stroke at the lever top from neutral to the stroke end using a ruler.

③ Repeat step ② three times and calculate the average values.

### (4) Evaluation

The measured drift should be within the following specifications.

Unit : mm

Model	Kind of lever	Standard	Maximum allowable	Remarks
R140W-9	Boom lever	$112 \pm 10$	134	
	Arm lever	$112 \pm 10$	134	
	Bucket lever	$90 \pm 10$	112	
	Swing lever	$90 \pm 10$	112	
	Travel lever	$139 \pm 10$	178	

## 11) PILOT PRIMARY PRESSURE

### (1) Preparation

- ① Keep the hydraulic oil temperature at  $50 \pm 5^\circ\text{C}$ .

### (2) Measurement

- ① Select the following switch positions.
  - Power mode switch : P mode
  - Auto decel switch : OFF
- ② Measure the primary pilot pressure by the monitoring menu of the cluster.

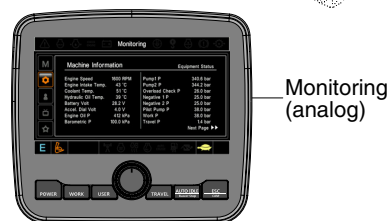
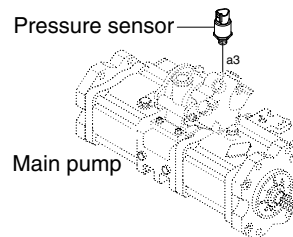

Cluster

14W97MS12

### (3) Evaluation

The average measured pressure should meet the following specifications:

Unit : kgf / cm<sup>2</sup>

Model	Kind of lever	Standard	Maximum allowable	Remarks
R140W-9	M mode	$40^{+2}_0$	-	

## 12) FOR TRAVEL SPEED SELECTING PRESSURE

### (1) Preparation

- ① Stop the engine.
- ② Loosen the cap and relieve the pressure in the hydraulic tank by pushing the top of the air breather.
- ③ To measure the speed selecting pressure : Install a connector and pressure gauge assembly to transmission J, M port as shown the figure.
- ④ Start the engine and check for on leakage from the adapter.
- ⑤ Keep the hydraulic oil temperature at  $50 \pm 5^{\circ}\text{C}$ .

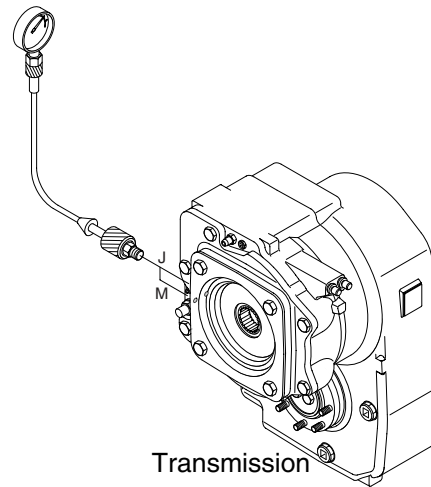

14W97MS13

### (2) Measurement

- ① Lower the bucket and dozer blade to the ground to raise the tires off the ground.
- ② Select the following switch position.
  - Parking switch : OFF
  - Power mode switch : P mode
- ③ Operate the travel speed switch turns to the high or lower position and measure the port J or M pressure.
- ④ Repeat steps ③ three times and calculate the average values.

### (3) Evaluation

The average measured pressure should be within the following specifications.

Unit : kgf / cm<sup>2</sup>

Model	Travel speed mode	Standard		Allowable limits		Remarks
		J port	M port	J port	M port	
R140W-9	Low Speed	-	33+2	-	30~35	
	High Speed	33+2	-	30~35	-	

### 13) SWING PARKING BRAKE RELEASING PRESSURE

#### (1) Preparation

- ① Stop the engine.
- ② Loosen the cap and relieve the pressure in the hydraulic tank by pushing the top of the air breather.
- ③ The pressure release L wrench to bleed air.
- ④ Install a connector and pressure gauge assembly to swing motor SH port, as shown.
- ⑤ Start the engine and check for oil leakage from the adapter.
- ⑥ Keep the hydraulic oil temperature at  $50 \pm 5^{\circ}\text{C}$ .

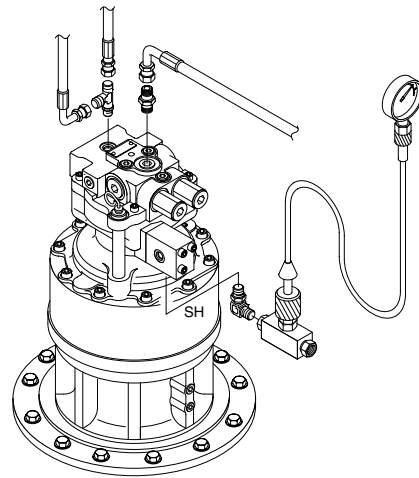

14W97MS14

#### (2) Measurement

- ① Select the following switch positions.
  - Power mode switch : P mode
- ② Operate the swing function or arm roll in function and measure the swing brake control pressure with the brake disengaged. Release the control lever to return to neutral and measure the control pressure when the brake is applied.
- ③ Repeat step ② three times and calculate the average values.

#### (3) Evaluation

The average measured pressure should be within the following specifications.

Unit : kgf / cm<sup>2</sup>

Model	Description	Standard	Allowable limits	Remarks
R140W-9	Brake disengaged	40	Over 9	
	Brake applied	0	-	

## 14) MAIN PUMP DELIVERY PRESSURE

### (1) Preparation

- ① Keep the hydraulic oil temperature at  $50 \pm 5^\circ\text{C}$ .

### (2) Measurement

- ① Select the following switch positions.
  - Power mode switch : P mode
- ② Measure the main pump delivery pressure in the P mode (high idle).

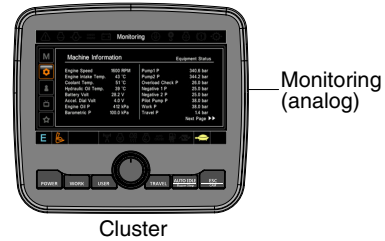
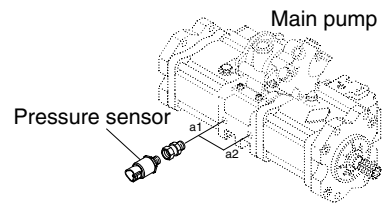

14W97MS15

### (3) Evaluation

The average measured pressure should meet the following specifications.

Unit : kgf / cm<sup>2</sup>

Model	Engine speed	Standard	Allowable limits	Remarks
R140W-9	High idle	$40^{+2}_0$	-	

## 15) SYSTEM PRESSURE REGULATOR RELIEF SETTING

### (1) Preparation

- ① Keep the hydraulic oil temperature at  $50 \pm 5^\circ\text{C}$ .

### (2) Measurement

- ① Select the following switch positions.
  - Power mode switch : P mode
- ② Slowly operate each control lever of boom, arm and bucket functions at full stroke over relief and measure the pressure.
- ③ In the swing function, place bucket against an immovable object and measure the relief pressure.
- ④ In the travel function, lock undercarriage with an immovable object and measure the relief pressure.

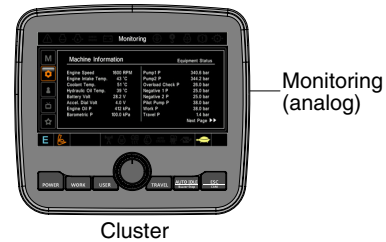
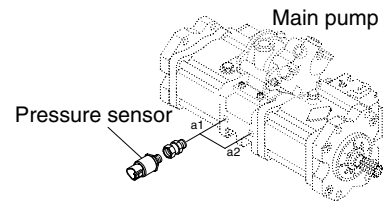

14W97MS15

### (3) Evaluation

The average measured pressure should be within the following specifications.

Unit :  $\text{kgf} / \text{cm}^2$

Model	Function to be tested	Standard	Port relief setting at 20lpm
R140W-9	Boom, Arm, Bucket	$350 (380) \pm 10$	$400 \pm 10$
	Travel	$380 \pm 10$	-
	Swing	$265 \pm 10$	-

( ) : Power boost