

GROUP 12 ENGINE CONTROL SYSTEM

1. MCU and Engine ECM (Electronic Control Module)

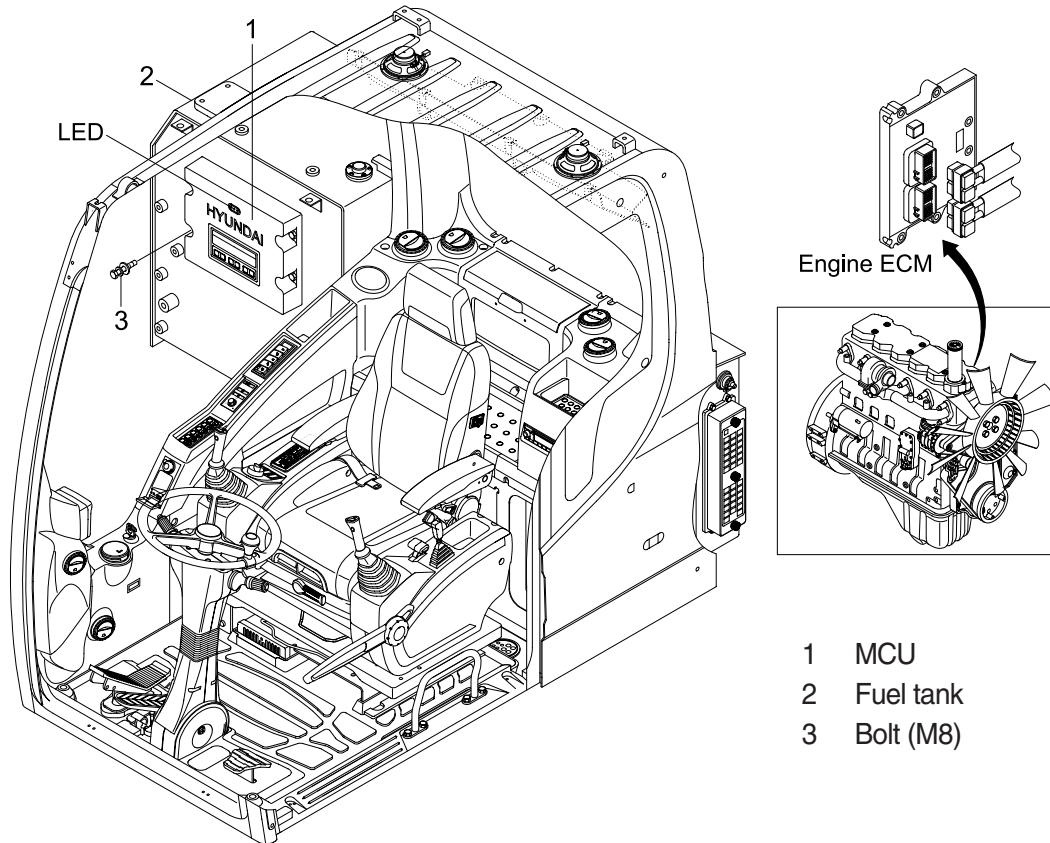

- 1 MCU
- 2 Fuel tank
- 3 Bolt (M8)

14W95MS13

2. MCU ASSEMBLY

- 1) To match the pump absorption torque with the engine torque, MCU varies EPPR valve output pressure, which control pump discharge amount whenever feedbacked engine speed drops under the reference rpm of each mode set.
- 2) Three LED lamps on the MCU display as below.

LED lamp	Trouble	Service
G is turned ON	Normal	-
G and R are turned ON	Trouble on MCU	• Change the MCU
G and Y are turned ON	Trouble on serial communication line	• Check if serial communication lines between controller and cluster are disconnected
Three LED are turned OFF	Trouble on MCU power	• Check if the input power wire (24 V, GND) of controller is disconnected • Check the fuse

G : green, R : red, Y : yellow