

GROUP 8 TRANSMISSION

1. STRUCTURE

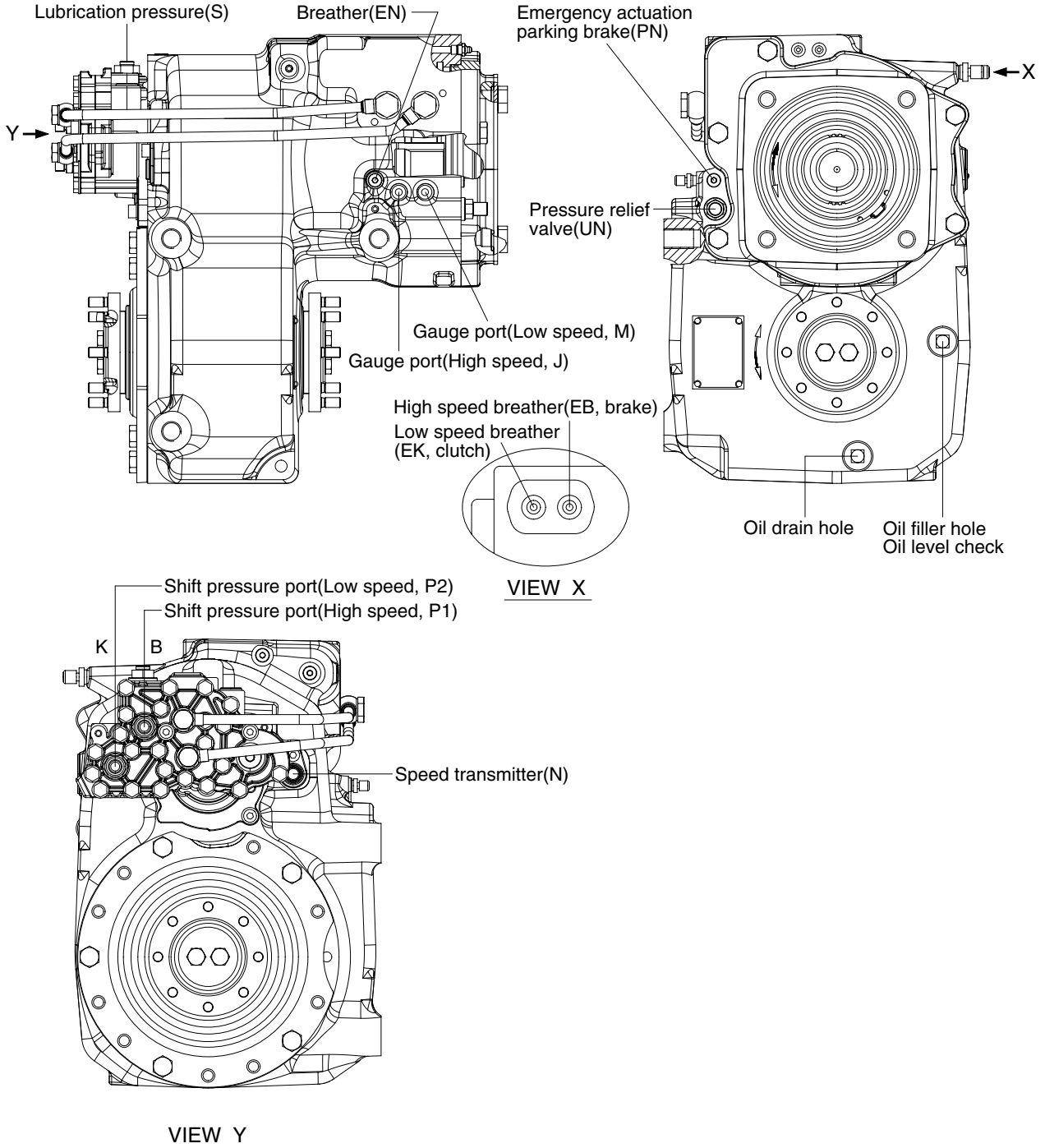

14W92TM01

2. TRANSMISSION DIAGRAM

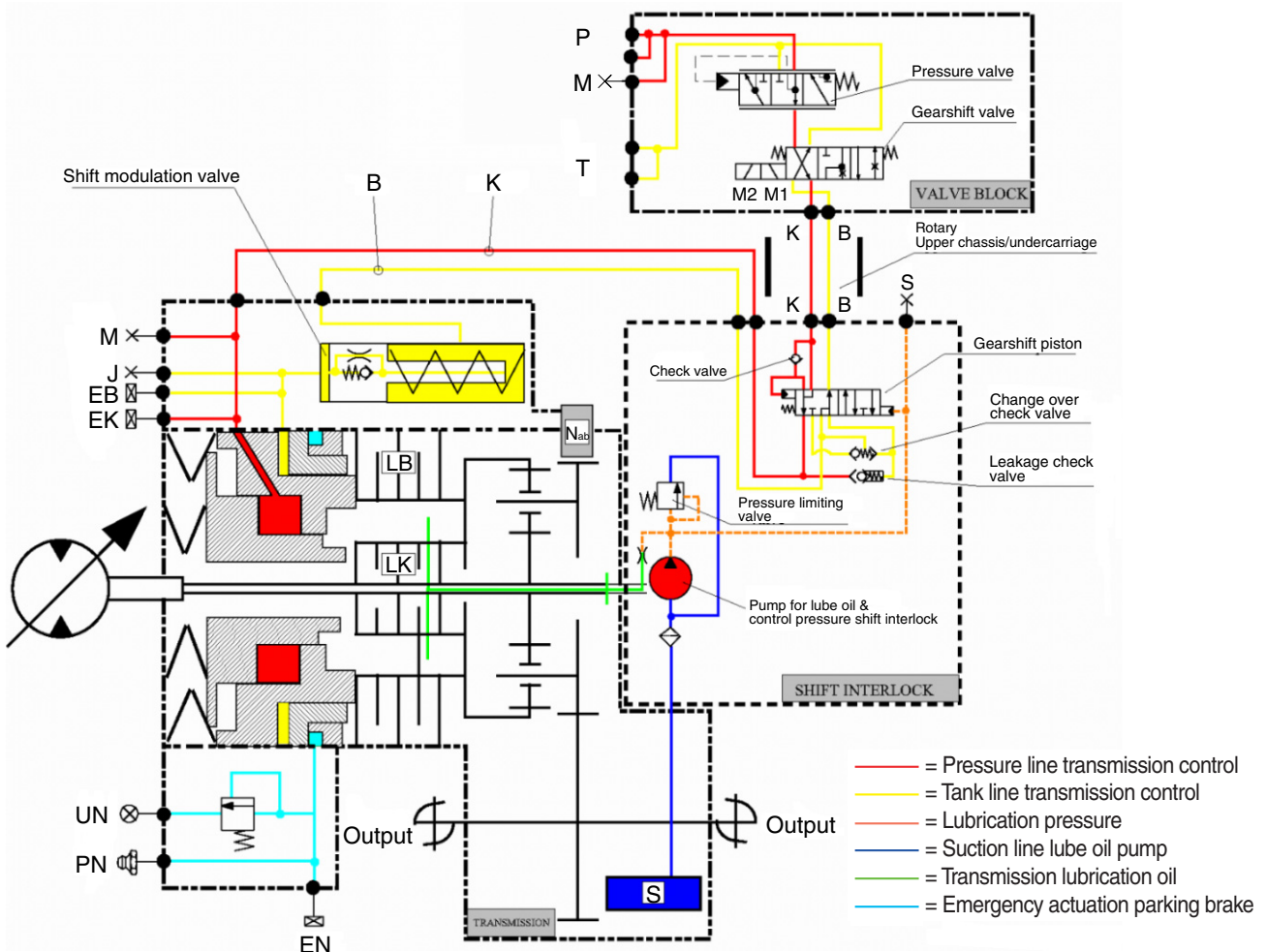

14W7A2TM02

Measuring points-Transmission/Shift interlock :

J : High speed (brake)

M : Low speed (clutch)

S : Lubrication pressure

Connections-Transmission/Shift interlock :

B : Brake

K : Clutch

PN : Emergency actuation parking brake

Measuring points-Valve block :

M : System pressure transmission control

Connections-Valve block :

P : System pressure transmission control

T : Tank

B : Brake

K : Clutch

Solenoid valves-valve block :

M1 : Solenoid valve (low speed)

M2 : Solenoid valve (high speed)

Port	Name	Size	Port	Name	Size
P1 (B)	Shift pressure, High speed	M16 × 1.5	M	Gauge port, Low speed	M10 × 1.0
P2 (K)	Shift pressure, Low speed	M16 × 1.5	S	Lubrication pressure port	M10 × 1.0
J	Gauge port, High speed	M10 × 1.0	PN	Parking brake lubricant	Grease nipple

3. OPERATION OF TRANSMISSION

1) DESCRIPTION

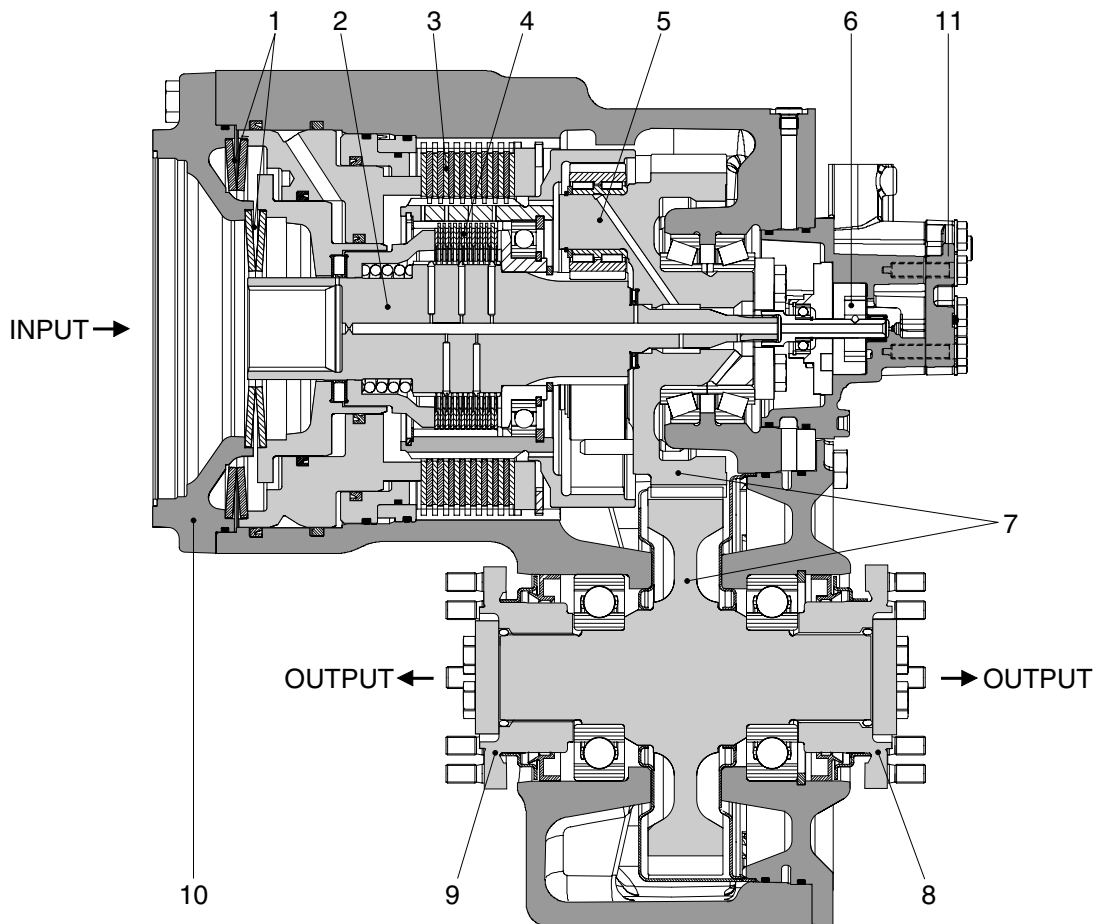

14W7A2TM03

- | | | | | | |
|---|-------------|---|-------------------------|----|--------------------------|
| 1 | Cup spring | 5 | Planetary drive | 9 | Output flange-Front axle |
| 2 | Input shaft | 6 | Lub oil pump | 10 | Travel motor attachment |
| 3 | Disk brake | 7 | Spur gear drive | 11 | Shift interlock |
| 4 | Disk clutch | 8 | Output flange-Rear axle | | |

Coaxially-mounted variable displacement travel motor (10) with specific displacement 107 cm³/rev.

The 2-speed powershift transmission comprises a planetary drive (5), a 2 shaft spur gear drive (7) with output flanges to front and rear axle.

The powershift mechanism for the planet drive comprises a rotating multi-disk clutch (4) underneath a multi-disk brake (3) rigidly connected to the housing. Both are closed by spring pressure (2) and released hydraulically.

The shift interlock (11) prevents downshifts at high machine speeds and thus prevents over-rotation of the travel motor. If the low speed gear is selected while the high speed gear is engaged and input speed is above approx. 1000rpm, the low speed gear shift is inhibited and only performed if input speed is below this limit. With higher viscosity oil (cold starting), the downshift is performed at a lower input speed. Upshifts are always possible. The speed-dependent interlock is effective in both directions. It does not prevent the possibility of over-rotation when the machine is coasting. For this, a drive brake valve should be fitted to the travel motor.

2) LOW SPEED (forward & reverse)

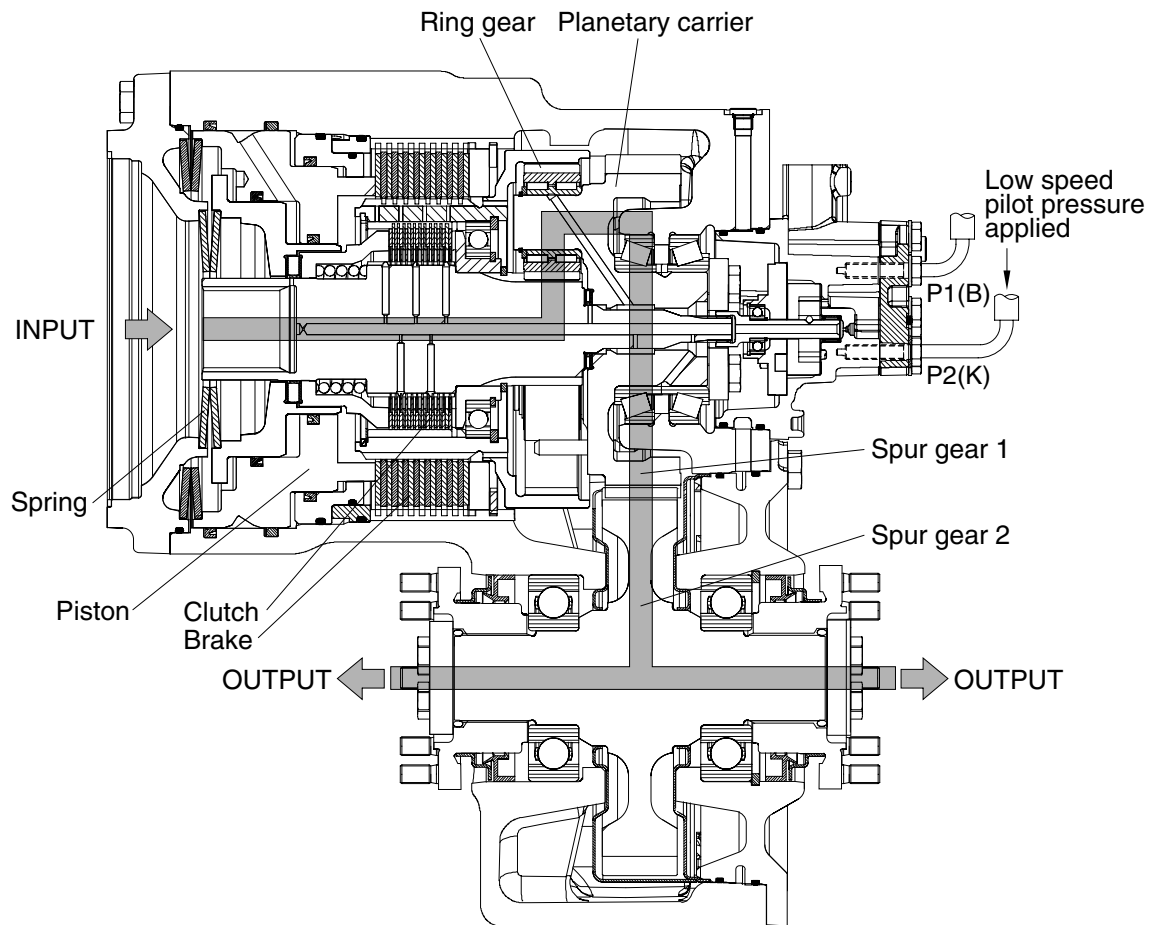

14W7A2TM04

In low speed operation, the internal gear of the planetary drive is backing upon the closed, case-rigid brake. In this speed the piston chamber of the brake is unpressurized, so that the elastic force and additionally the hydraulic pressure of the clutch piston is acting upon the disk pack. At this time the clutch is open, i.e. the hydraulic released.

3) HIGH SPEED (forward & reverse)

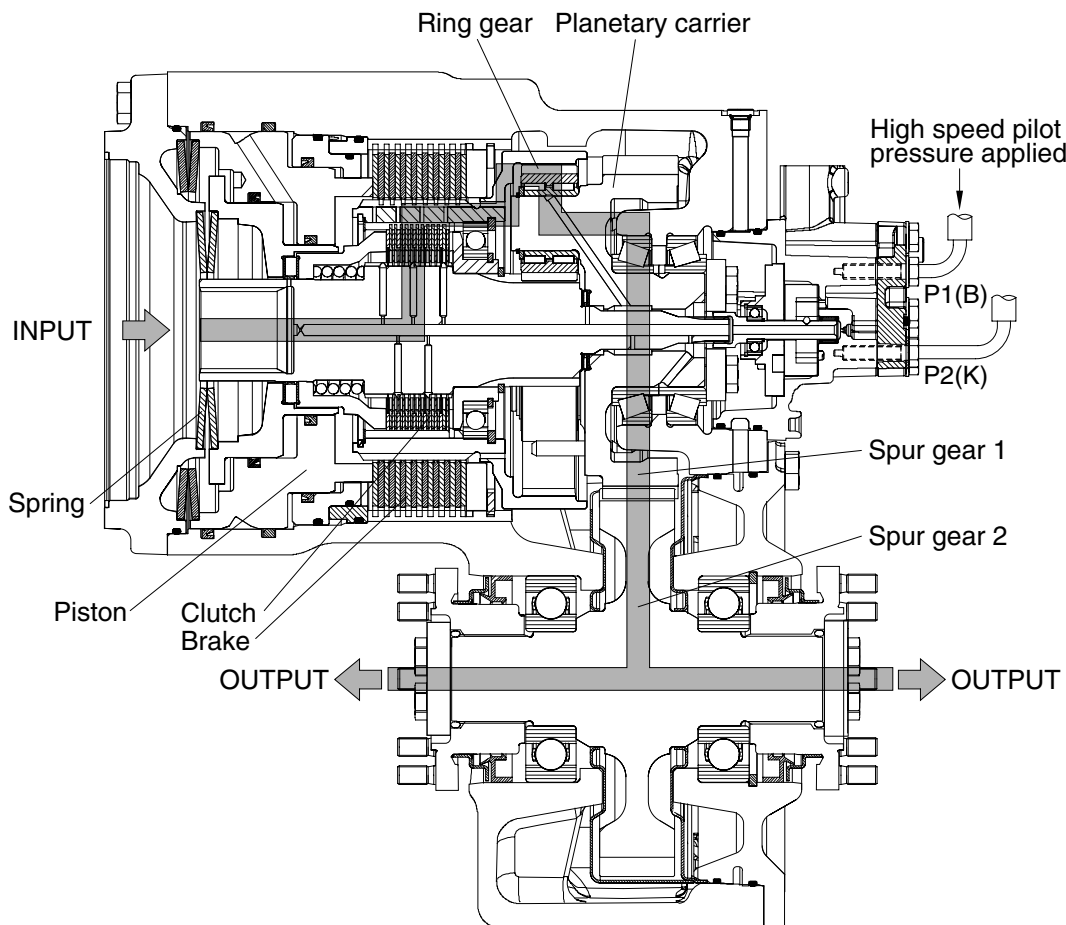

14W7A2TM05

In high speed operation, the clutch is held closed under spring pressure and the brake is hydraulically opened.

When a gear shift occurs-for example from high speed to low speed gear- the oil from the brake piston space is fed back to the tank through a restrictor (change over check valve) due to the spring pressure acting on the brake piston. At the same time the clutch is filled with oil and opened. Required oil flow is necessary for the transmission control to ensure the clutch is open before the brake begins to transmit torque.

A shift modulation valve is also integrated in the transmission. This modulates the pressure sequence at the brake during an upshift in order to achieve good shift quality.

The gear shift equipment also has the function of a parking brake. When the brake is operated-for example with high speed gear engaged-the clutch is closed and is statically loaded.

4) BRAKES

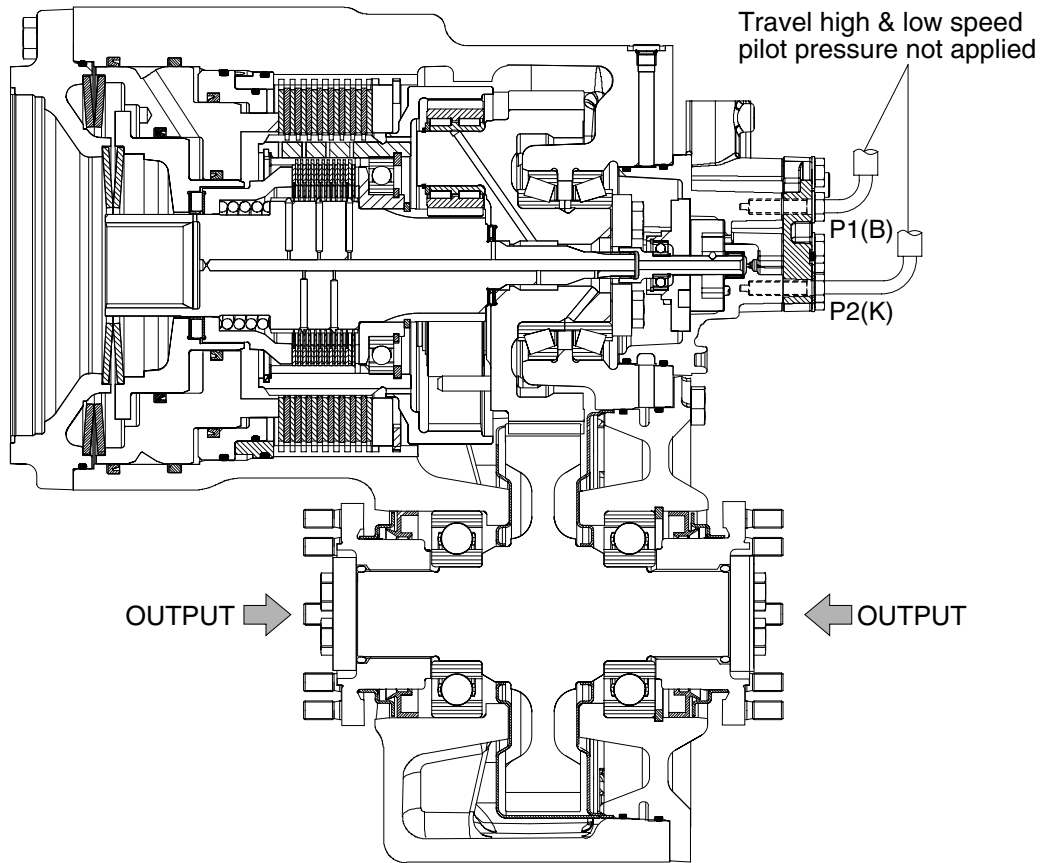

14W7A2TM06

When the travel high/low speed pilot pressure is not applied in the piston space, the piston compress against the multi disk pack due to the spring force. Thus the parking brake is engaged.

4. TECHNICAL DATA

1) GENERAL DATA

- (1) Max input power : 110 kW
- (2) Max input torque : 78.5 kgf · m
- (3) Max output speed : 3500 rpm
- (4) Hydraulic motor : 140 cm³/rev
- (5) Transmission ratio
Gear step : 4.06
 - Low speed gear : 4.87
 - High speed gear : 1.20
- (6) Shift interlock
Downshift possible at operating temperature with input speed 1000rpm (downshift point lower when oil temperature cold).
- (7) Disconnection device
For towing away machine auxiliary release device for parking brake.
- (8) Brake
Parking brake. Necessary brake deceleration by controlled locking of planetary drive. Braking torque depends on opening pressure set at brake valve (13 bar).
- (9) Output flange
Bolts for propshaft connection : M10 × 1.0 (class 10.9)
- (10) Transmission weight : 135kg

2) TRANSMISSION CONTROL

Following data are valid for oil temperature 30°C to 40°C in hydraulic tank, measured at connections at powershift transmission (see structure and diagram).

- (1) Control pressure
 - ① At connection P1 and P2 at Low/High engine speed : 33+1 kgf/cm²
 - ② Definition of lubricants : API GL-5, SAE 10W-30, 15W-40
- (2) Oil flow
 - ① Min oil flow at 24+1 kgf/cm² counter pressure (low engine speed) : 5.5 l /min
 - ② Max oil flow : 25 l /min
- (3) Residual pressure
 - ① Max residual pressure in control line to tank connection P1 and P2 : 1.0 kgf/cm²
- (4) Leakage oil transmission control
 - ① Pressure in input housing connection (E) max : 1.0 kgf/cm²
 - ② Max oil flow (low speed actuated) : 1 l /min