

GROUP 5 POWER TRAIN SYSTEM

1. POWER TRAIN MOUNTING

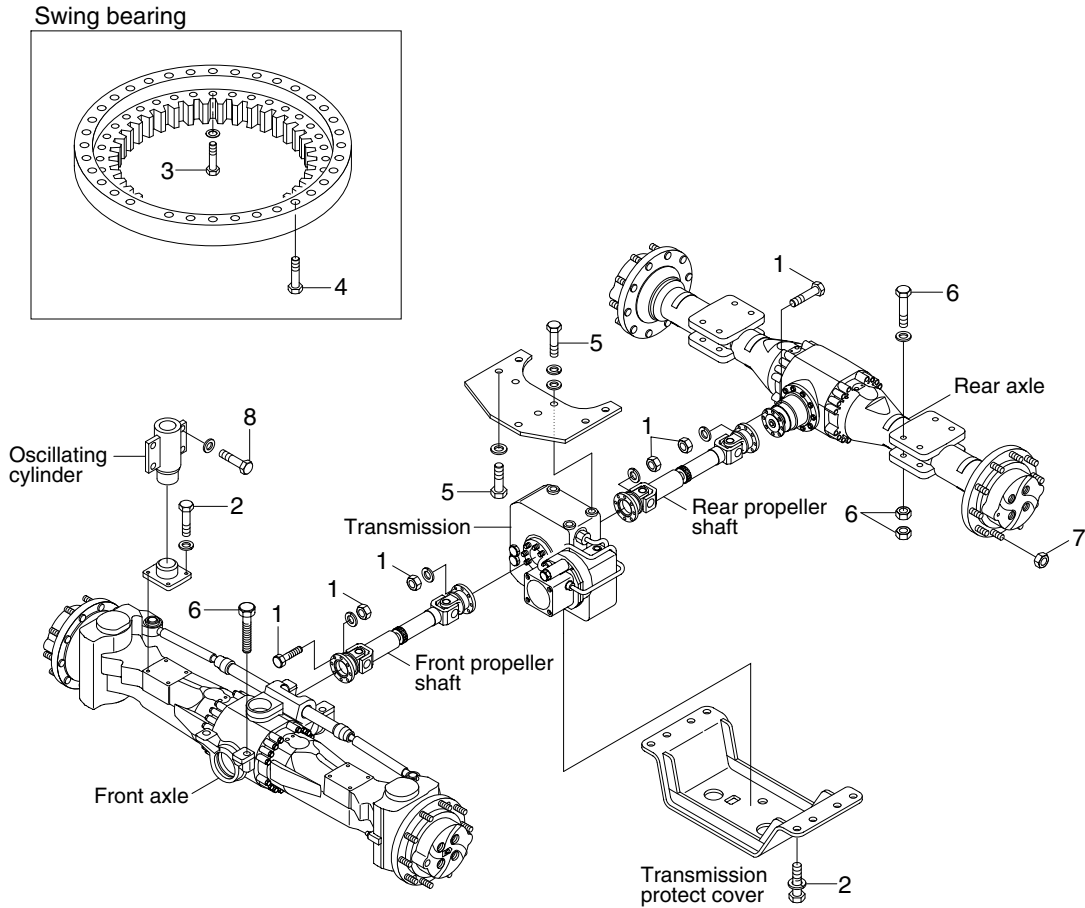

14W7A9CM08

· Tightening torque

Item	Size	kgf · m	lbf · ft
1	M10×1.0	5.9±0.6	42.7±4.3
2	M12×1.75	12.3±2.5	89.0±18
3	M16×1.5	31.3±3.2	226±23
4	M18×2.5	41.3±4.5	299±44.8

Item	Size	kgf · m	lbf · ft
5	M20×2.5	44±2.0	318±14.4
6	M20×2.5	58±6.3	420±46
7	M22×1.5	62±3.0	448±21.7
8	M22×1.5	83.2±9.2	602±66.5

2. COVER AND FOOT BOARD

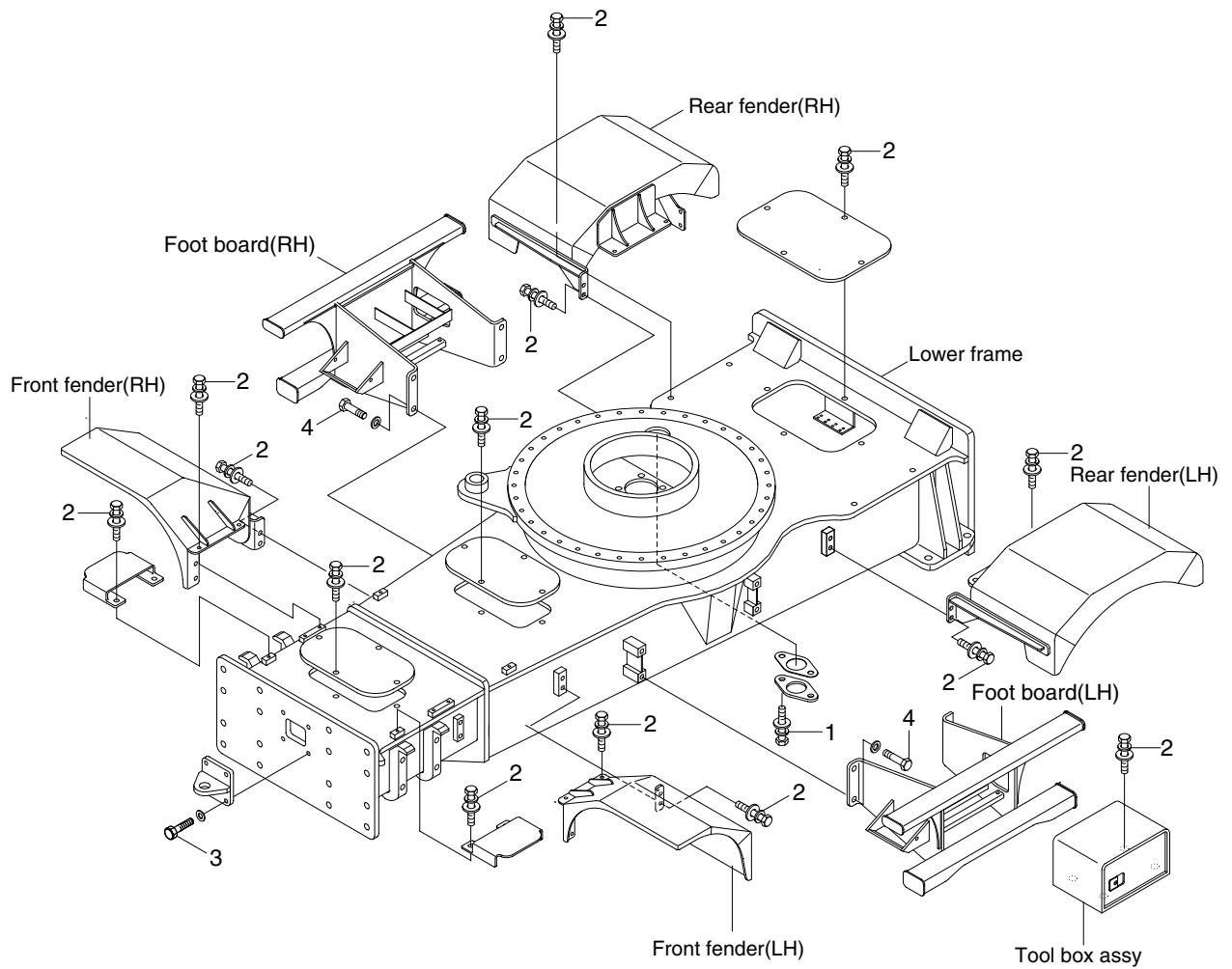

14W7A9CM09

· Tightening torque

Item	Size	kgf · m	lbf · ft
1	M10×1.5	6.9±1.4	49.9±10.1
2	M12×1.75	12.8±3.0	92.6±21.7

Item	Size	kgf · m	lbf · ft
3	M16×2.0	29.7±4.5	215±32.5
4	M20×2.5	57.9±8.7	419±62.9