

## GROUP 2 HYDRAULIC AND MECHANICAL SYSTEM

### 1. INTRODUCTION

#### 1) MACHINE IN GENERAL

- (1) If even a minor fault is left intact and operation is continued, a fatal failure may be caused, entailing a large sum of expenses and long hours of restoration.  
Therefore when even a small trouble occurs, do not rely on your intuition and experience, but look for the cause based on the troubleshooting principle and perform maintenance and adjustment to prevent major failure from occurring. Keep in mind that a fault results from a combination of different causes.
- (2) The following lists up commonly occurring faults and possible causes with this machine. For the troubleshooting of the engine, refer to the coming troubleshooting and repair.
- (3) When carrying out troubleshooting, do not hurry to disassemble the components.  
It will become impossible to find the cause of the problem.
- (4) Ask user or operator the following.
  - ① Was there any strange thing about machine before failure occurred?
  - ② Under what conditions did the failure occur?
  - ③ Have any repairs been carried out before the failure?
- (5) Check before troubleshooting.
  - ① Check oil and fuel level.
  - ② Check for any external leakage of oil from components.
  - ③ Check for loose or damage of wiring and connections.

## 2. DRIVE SYSTEM

### 1) UNUSUAL NOISE COMES OUT OF PUMP CONNECTION

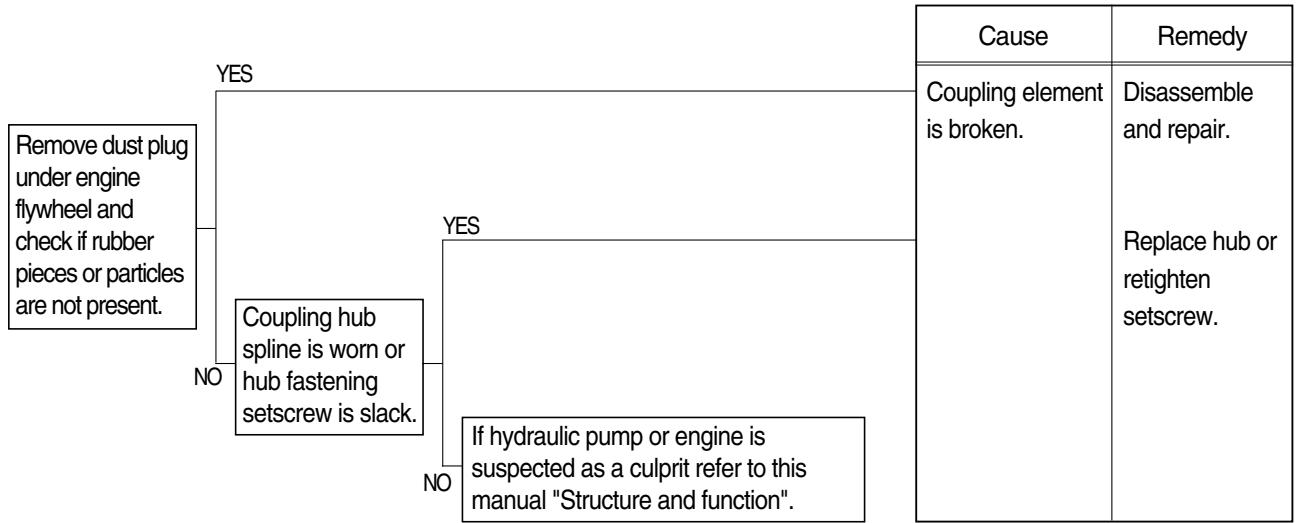

## 2) ENGINE STARTS BUT MACHINE DOES NOT OPERATE AT ALL

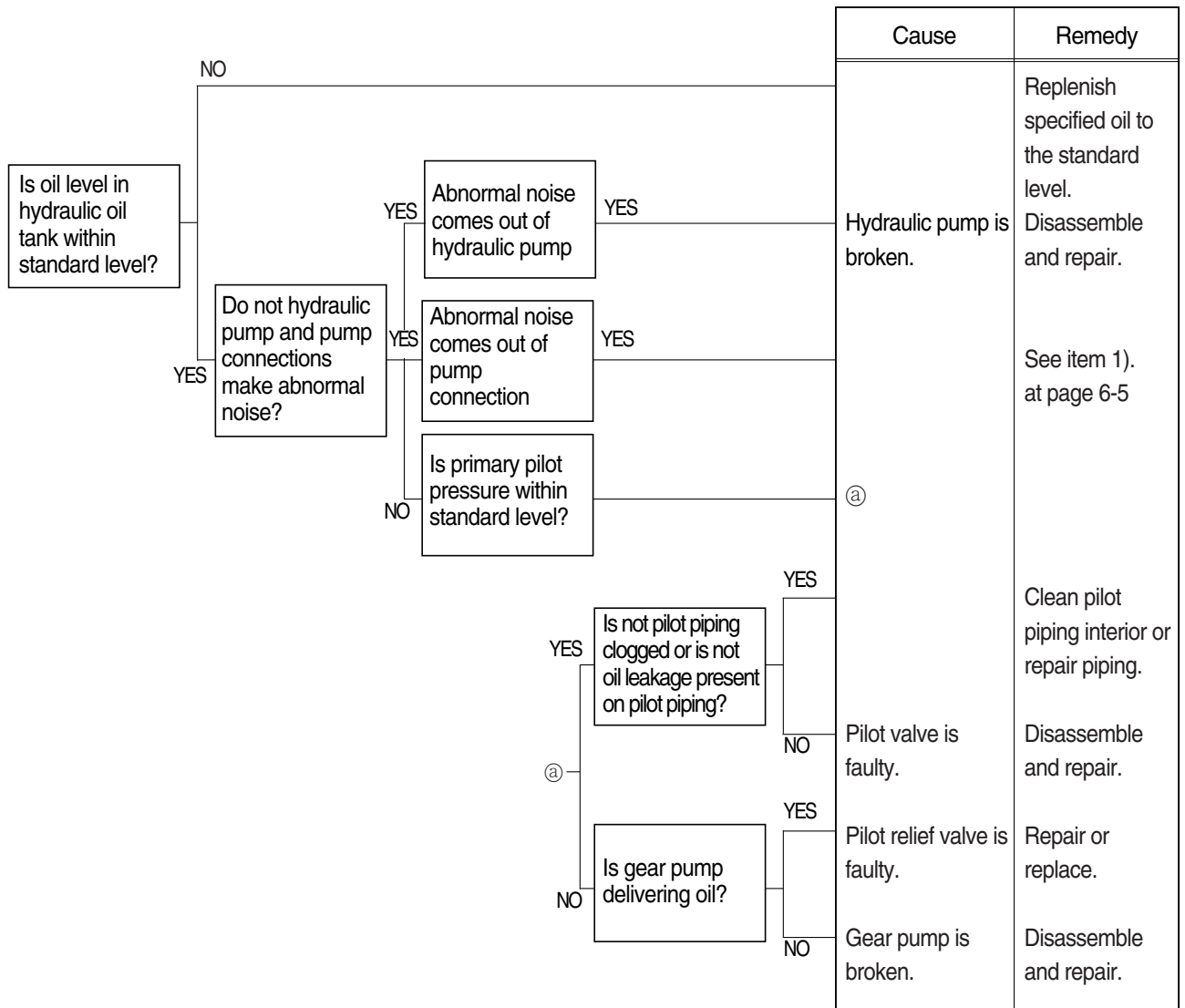

### 3. HYDRAULIC SYSTEM

#### 1) HYDRAULIC OIL IS CLOUDY

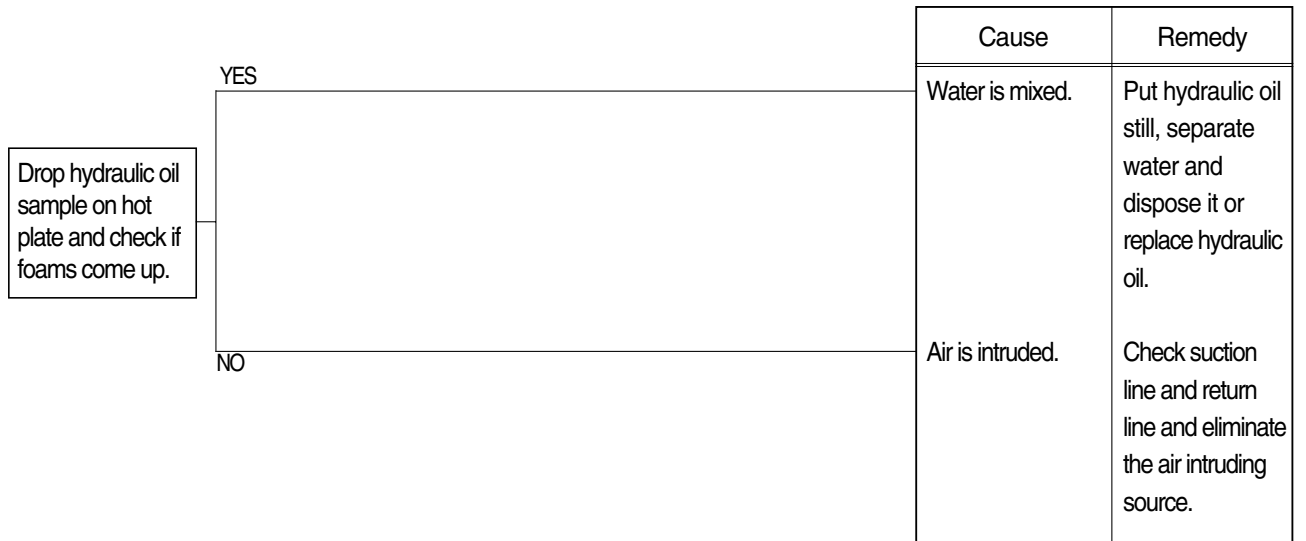

#### 2) HYDRAULIC OIL TEMPERATURE HAS RISEN ABNORMALLY

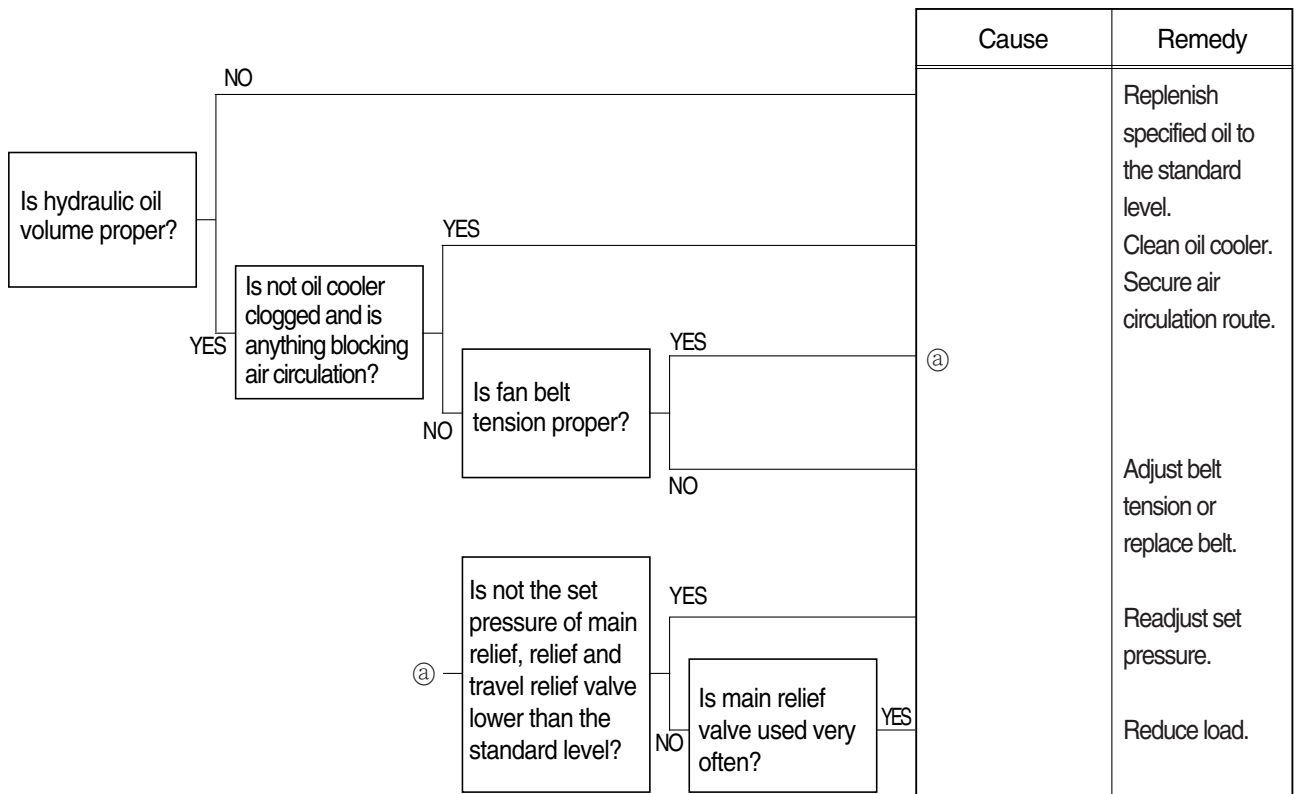

### 3) CAVITATION OCCURS WITH PUMP

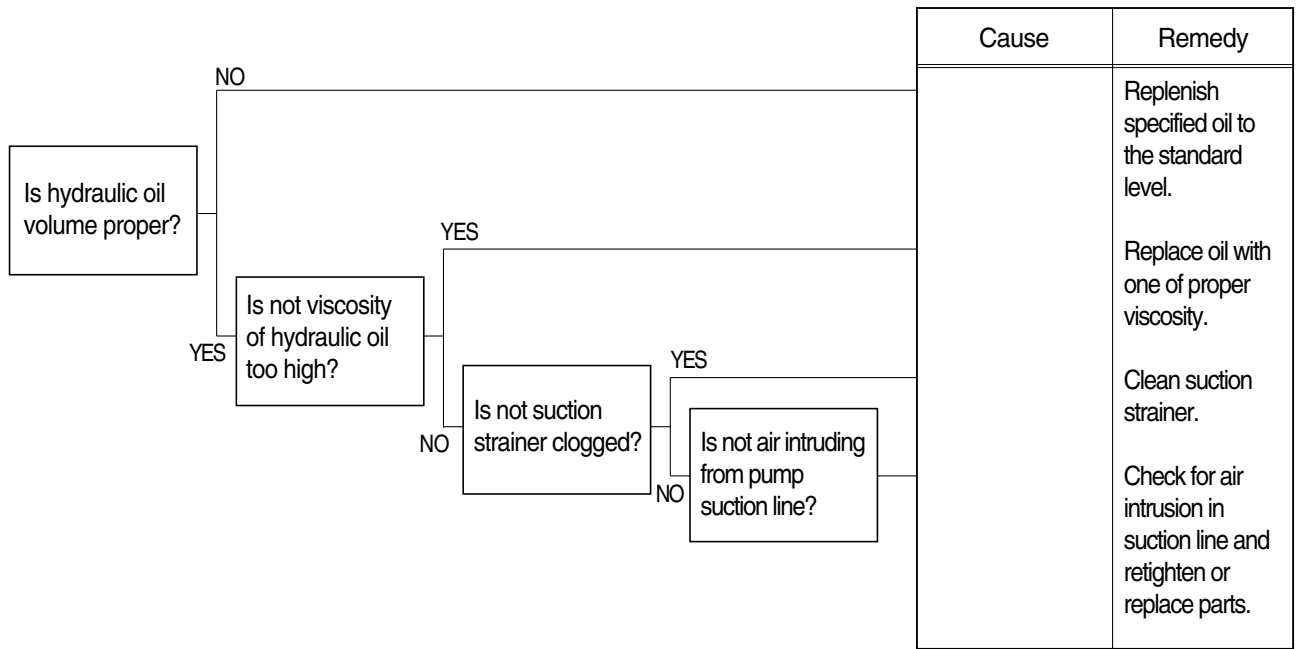

### 4) HYDRAULIC OIL IS CONTAMINATED

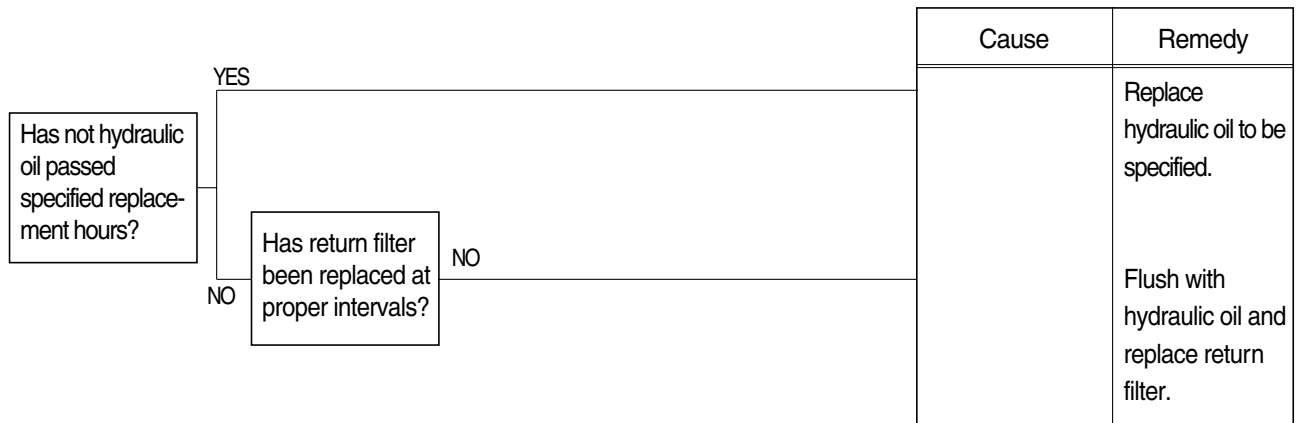

## 4. SWING SYSTEM

### 1) BOTH LH AND RH SWING ACTIONS ARE IMPOSSIBLE

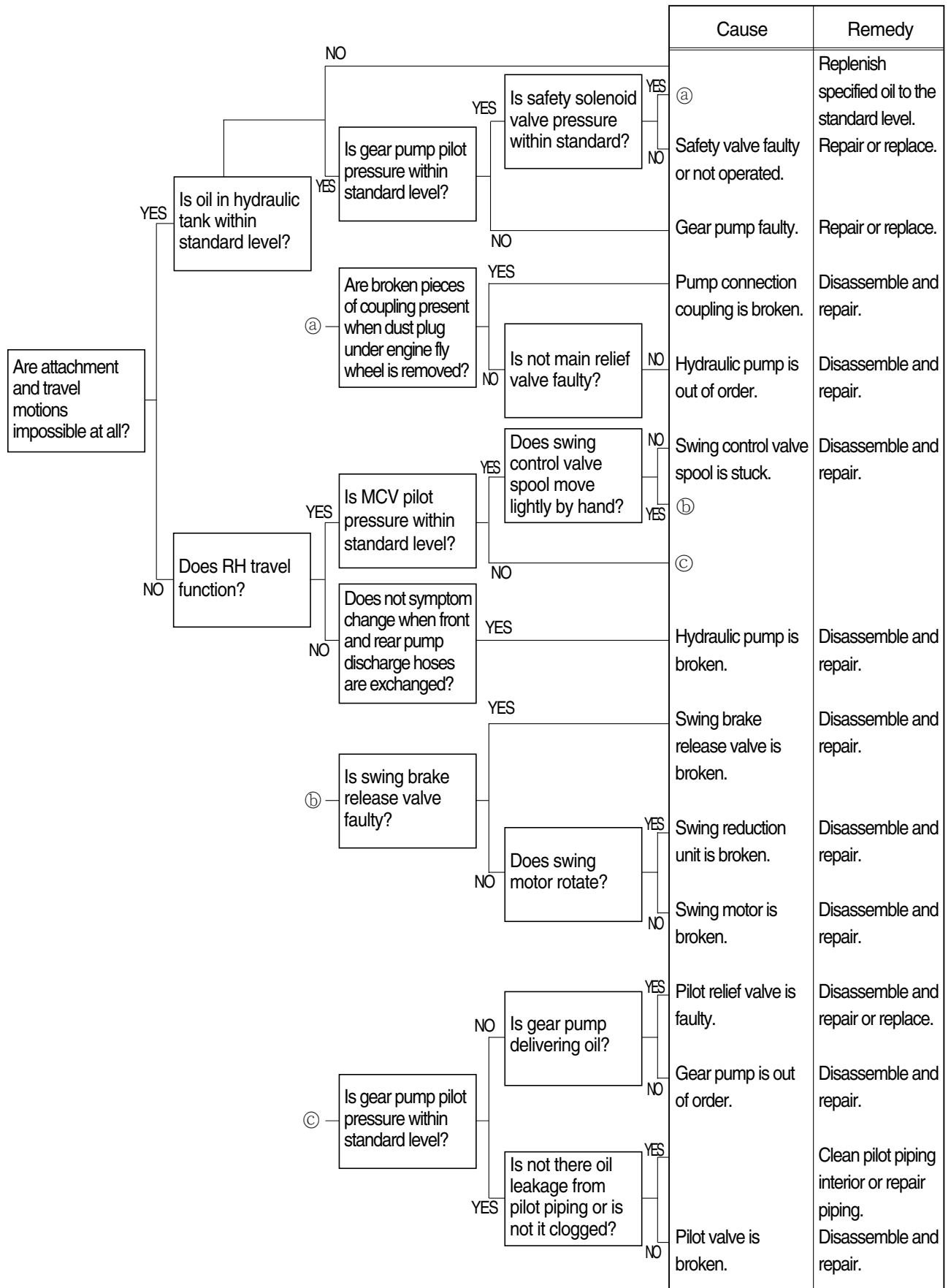

## 2) SWING SPEED IS LOW

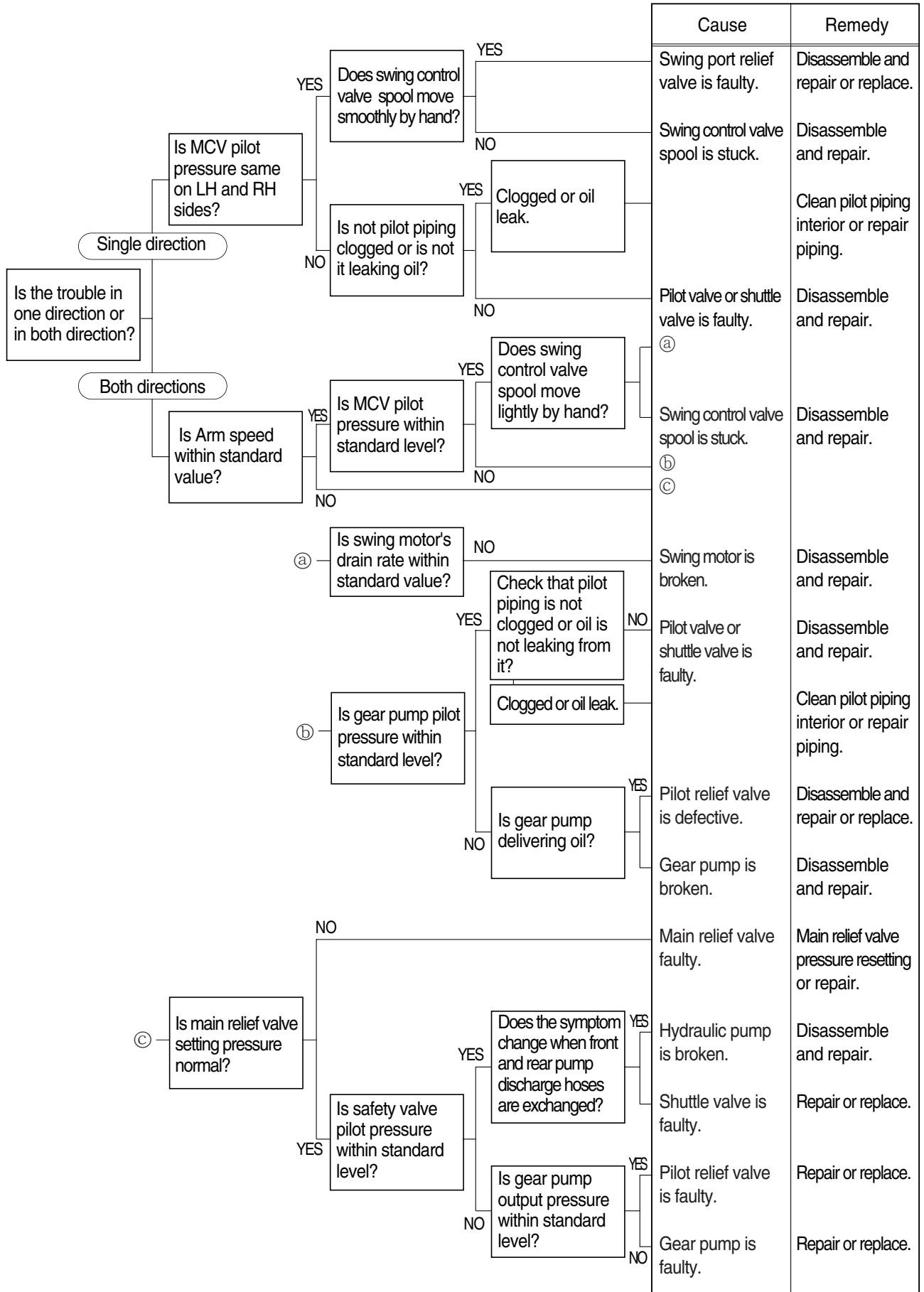

### 3) SWING MOTION IS IMPOSSIBLE IN ONE DIRECTION

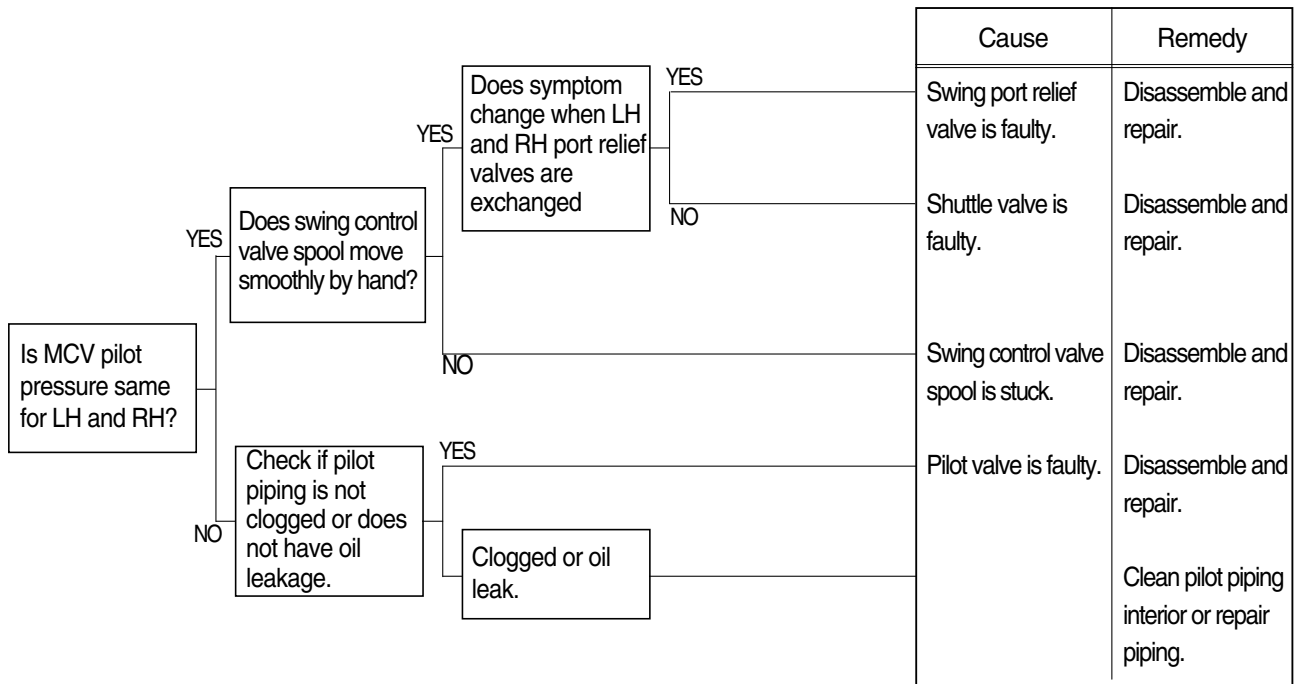

### 4) MACHINE SWINGS BUT DOES NOT STOP

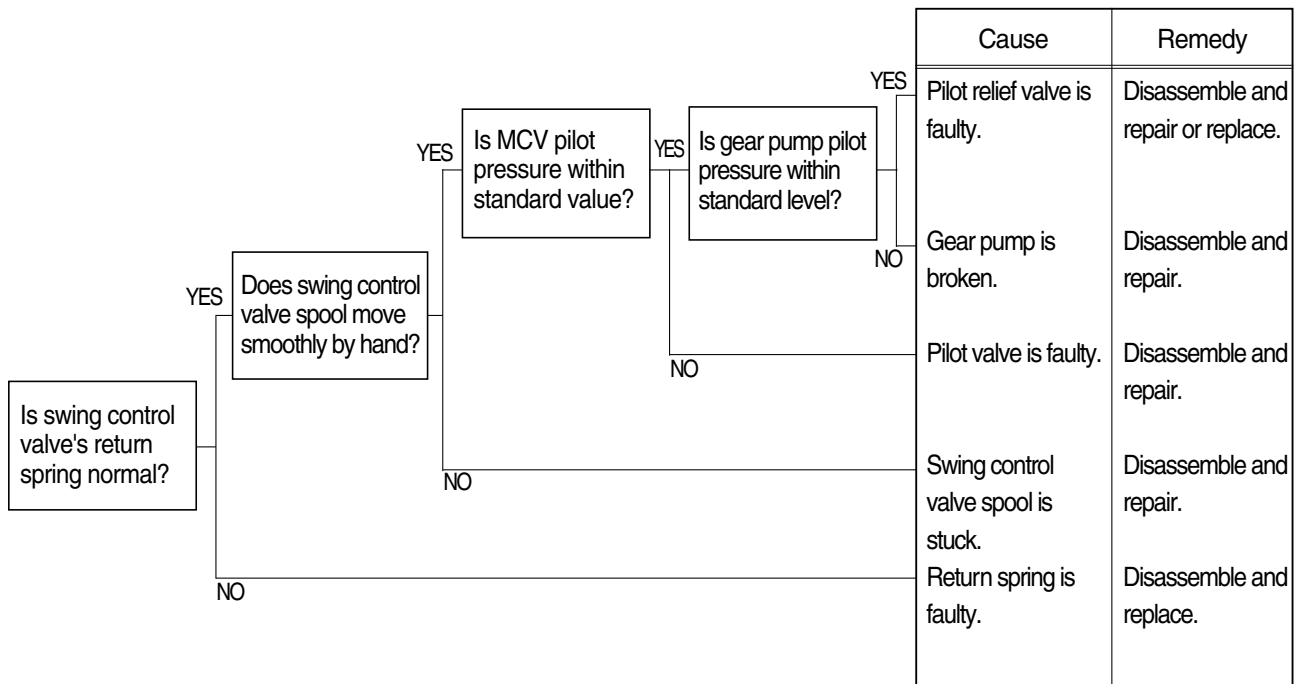

5) THE SWING UNIT DRIFTS WHEN THE MACHINE IS AT REST ON A SLOPE

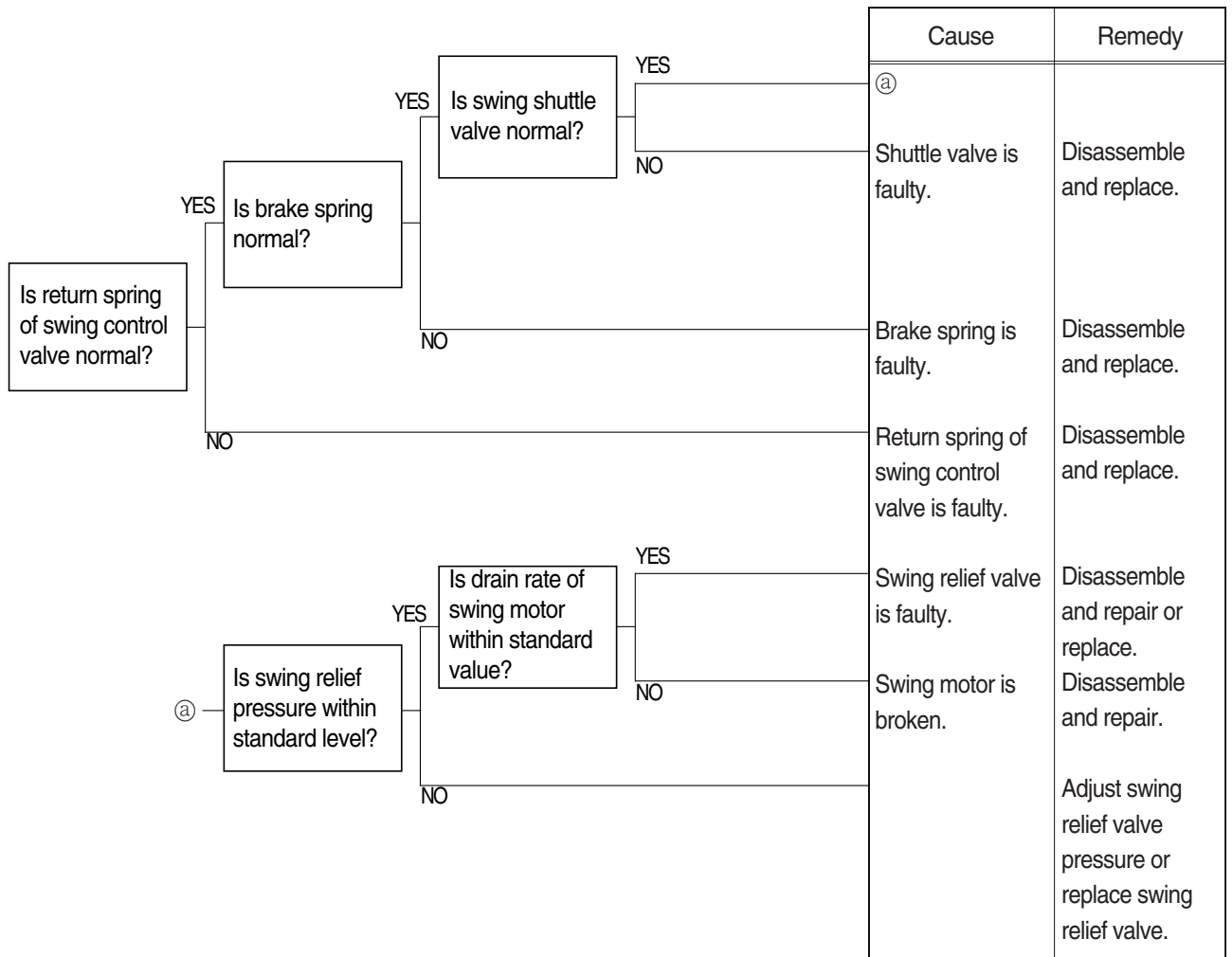

## 5. TRAVEL SYSTEM

### 1) TRAVEL DOES NOT FUNCTION AT ALL ON ONE SIDE

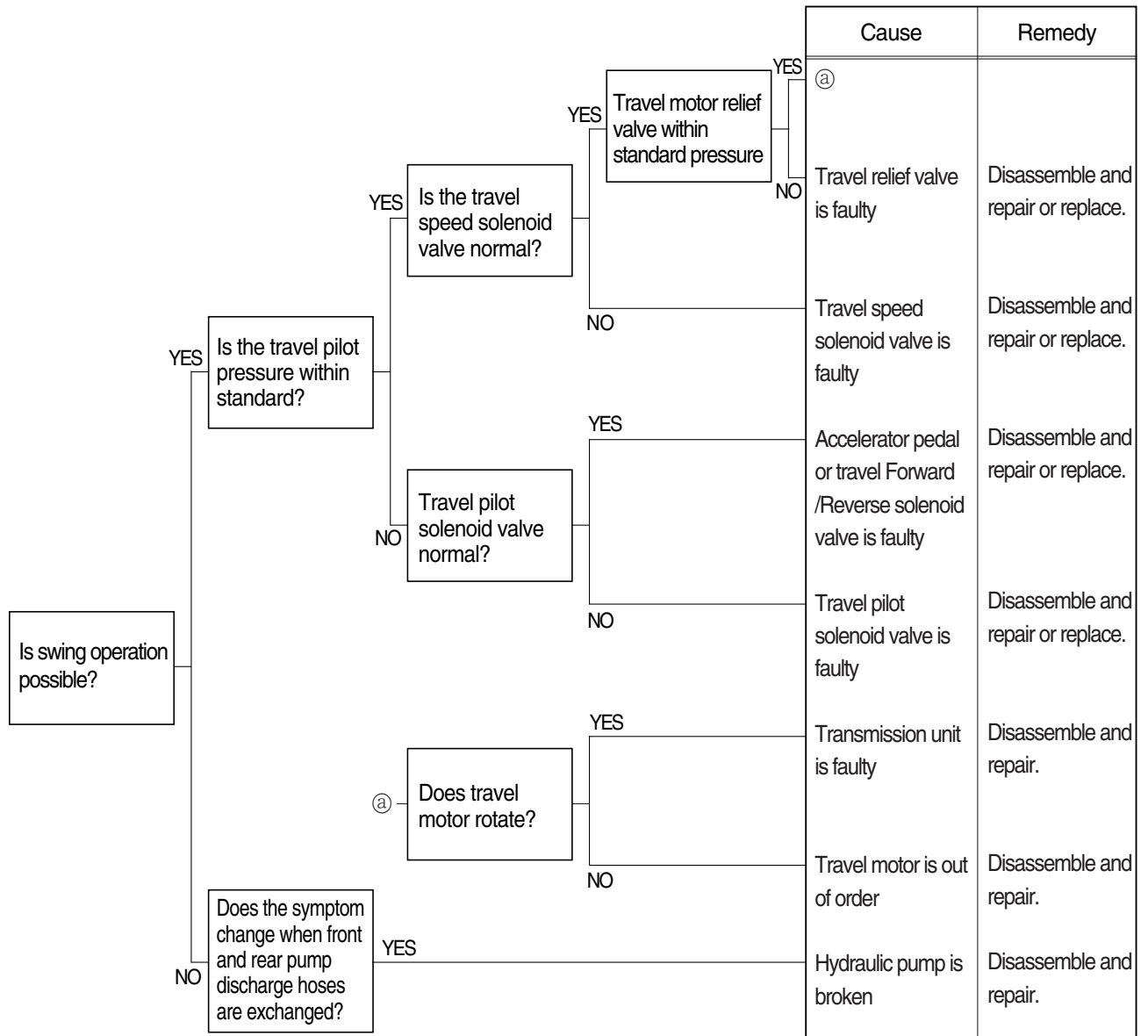

2) TRAVEL ACTION IS POWERLESS(Travel only)

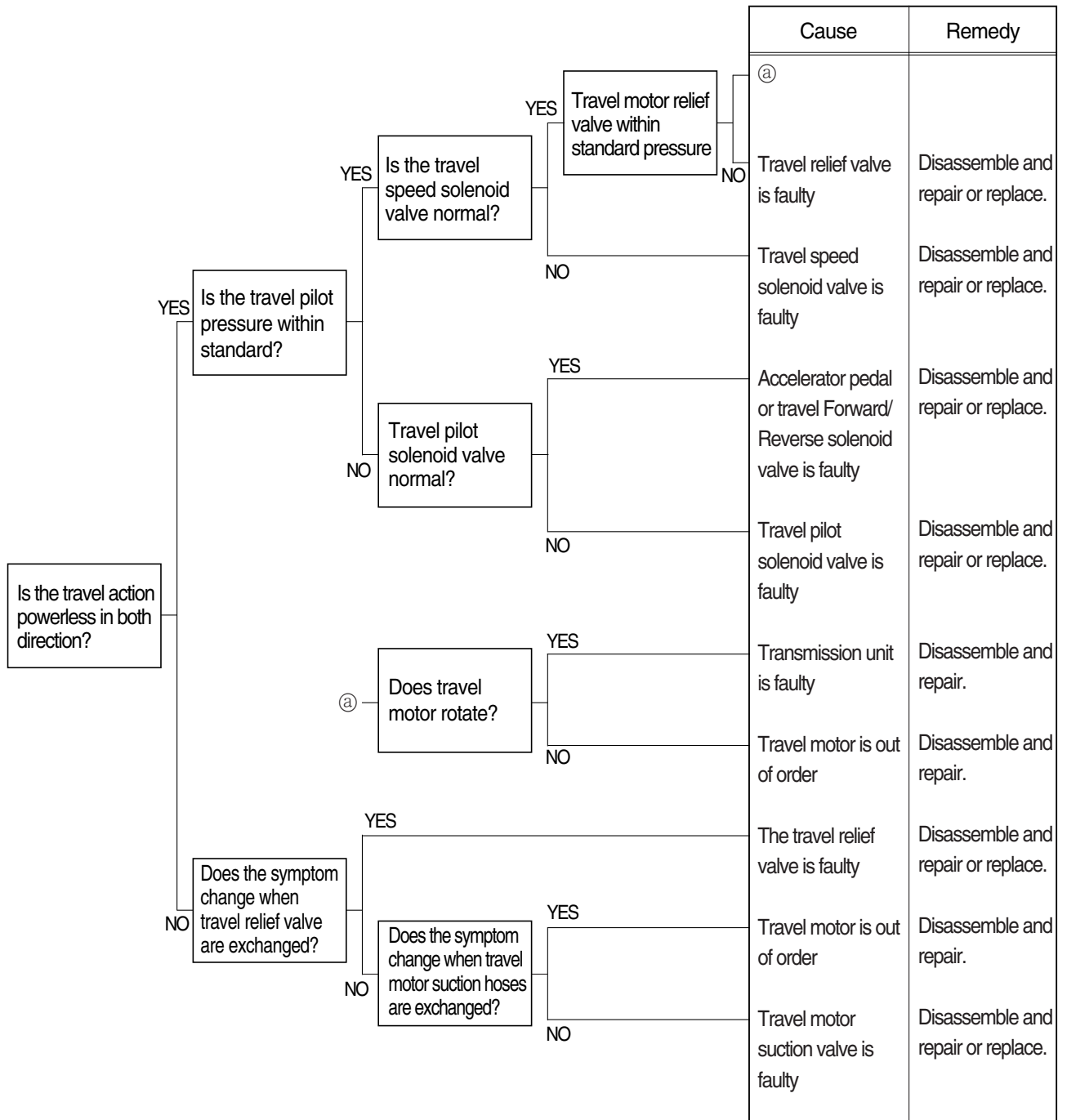

### 3) THE HYDRAULIC MOTOR DOES NOT GET STARTED

The hydraulic motor does not get started	Cause	Remedy
	<p>The spool does not work properly. (The spool keeps fully open)</p>	<p>Screw the fitting bolts one more time with correct tightening torque. If the spool turns out to be damaged, it should be repaired or the new one should be used</p>
<p>The anti-cavitation check valve does not work properly. (The check valve is kept open.)</p>	<p>The anti-cavitation check valve does not work properly. (The check valve is kept open.)</p>	<p>Ditto</p>

### 4) IT TAKES TIME TO ACCELERATE THE MOTOR

It takes time to accelerate the motor	Cause	Remedy	
	<p>The spool does not work properly.</p>	<p>The spool does not work properly.</p>	<p>Screw the fitting bolts one more time with correct tightening torque. If the spool turns out to be damaged, it should be repaired, or the new one should be used.</p>
	<p>The orifice for closing the counterbalance is clogged.</p>	<p>The orifice for closing the counterbalance is clogged.</p>	<p>Remove the foreign matter by disassembling and cleaning.</p>
<p>Wrong setting of pressure of the relief valve.</p>	<p>Wrong setting of pressure of the relief valve.</p>	<p>Adjust at the correct value. If the relief valve turns out to be out of order, the new one should be used.</p>	

**5) IT IS NOT POSSIBLE TO REDUCE THE MOTOR SMOOTHLY**

It is not possible to reduce the motor smoothly		<b>Cause</b>	<b>Remedy</b>
		The orifice for closing the counterbalance is clogged. The opening of the neutral position of the spool is clogged.	Remove the foreign matter by disassembling and cleaning.
		Wrong setting of pressure of the relief valve.	Adjust at the correct value. If the relief valve turns out to be out of order, the new one should be used.

**6) EXTRAORDINARY NOISE IS HEARD WHEN SUDDENLY REDUCING THE SPEED FROM THE HIGH-SPEED MODE**

It takes time to accelerate the motor		<b>Cause</b>	<b>Remedy</b>
		The anti-cavitation valve does not work properly.	Screw the fitting bolts one more time with correct tightening torque. If the valve turns out to be damaged, it should be repaired.

## 6. ATTACHMENT SYSTEM

### 1) BOOM OR ARM ACTION IS IMPOSSIBLE AT ALL

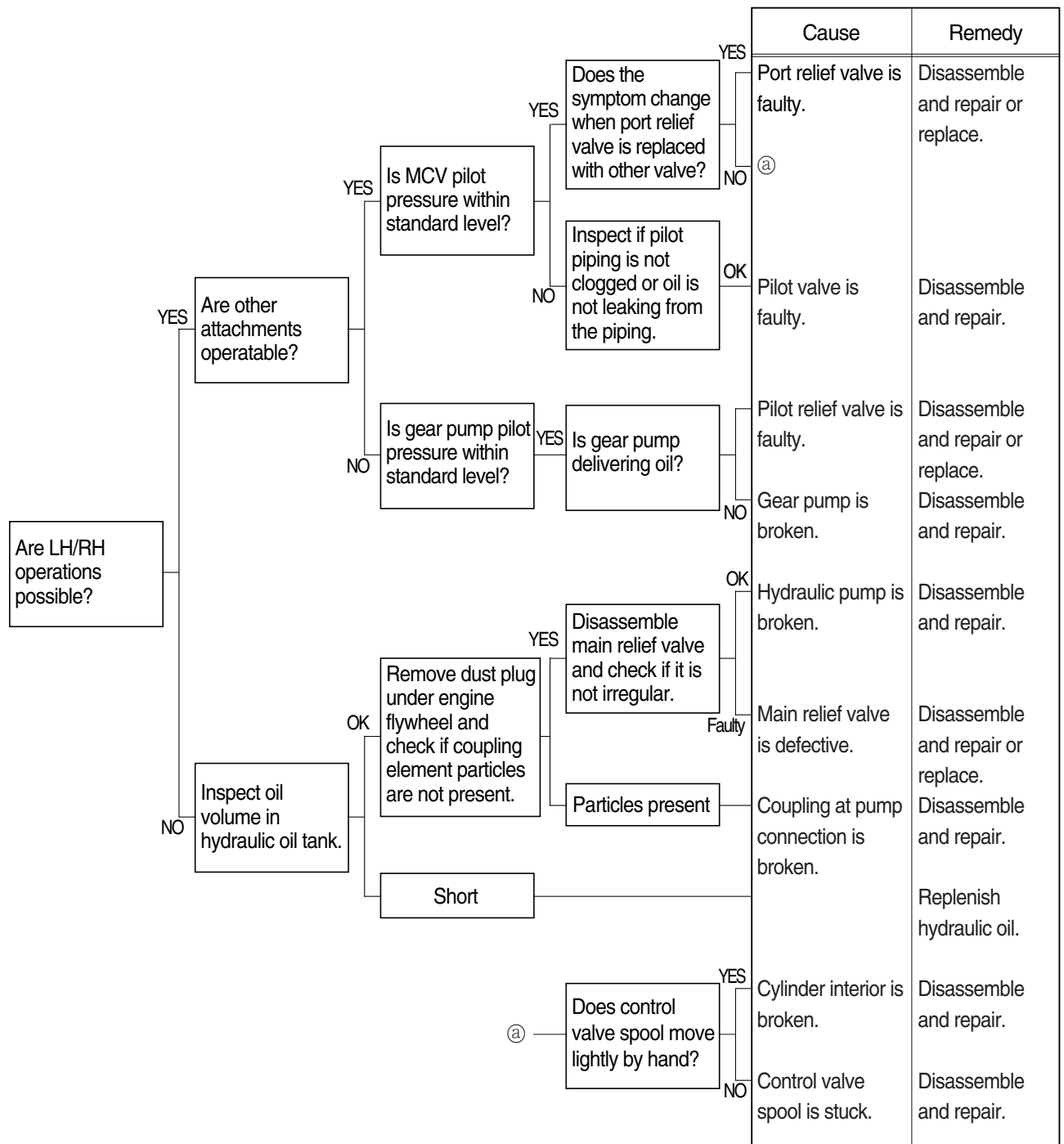

## 2) BOOM, ARM OR BUCKET SPEED IS LOW

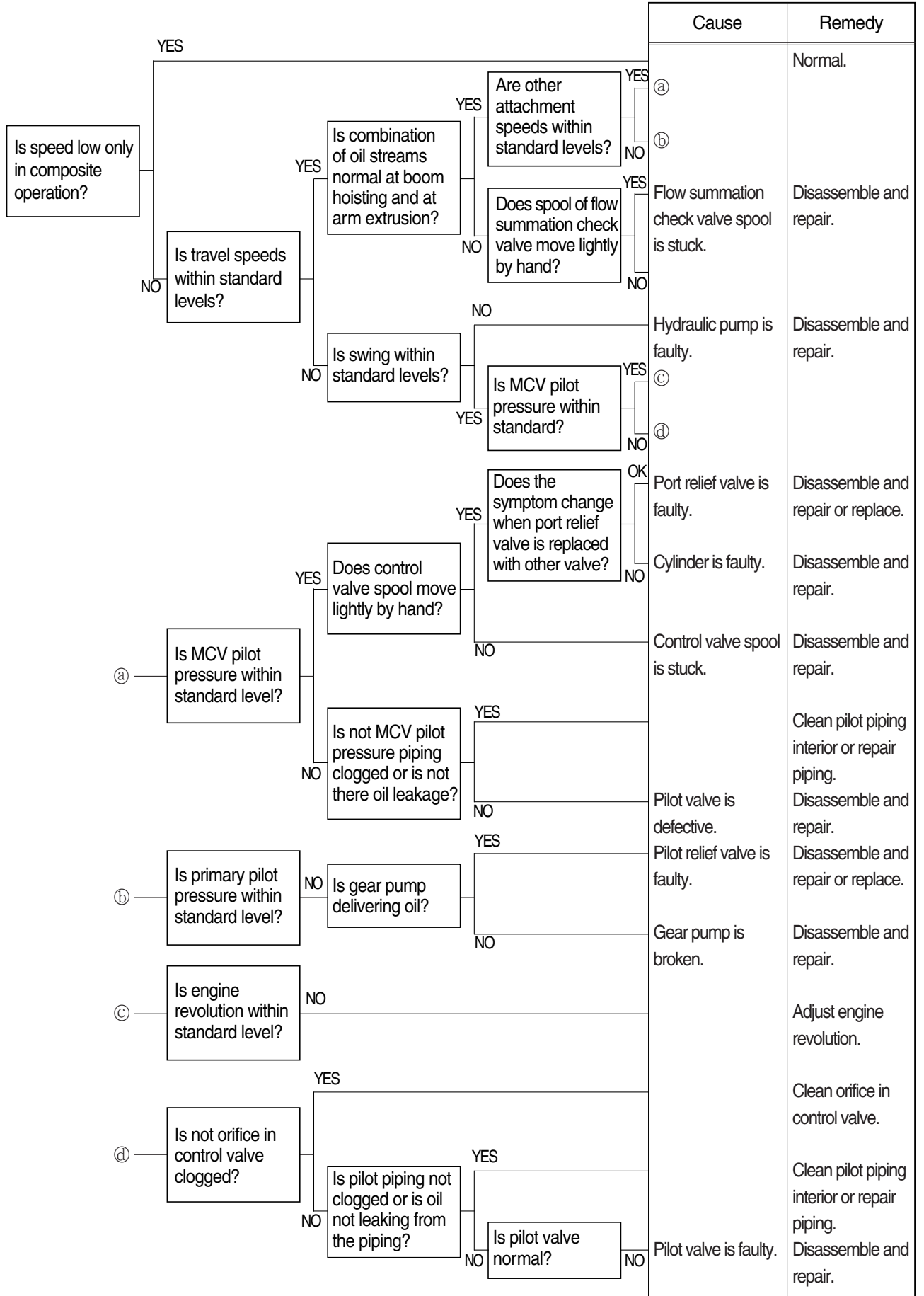

### 3) BOOM, ARM OR BUCKET CYLINDER EXTENDS OR CONTRACTS ITSELF AND ATTACHMENT FALLS

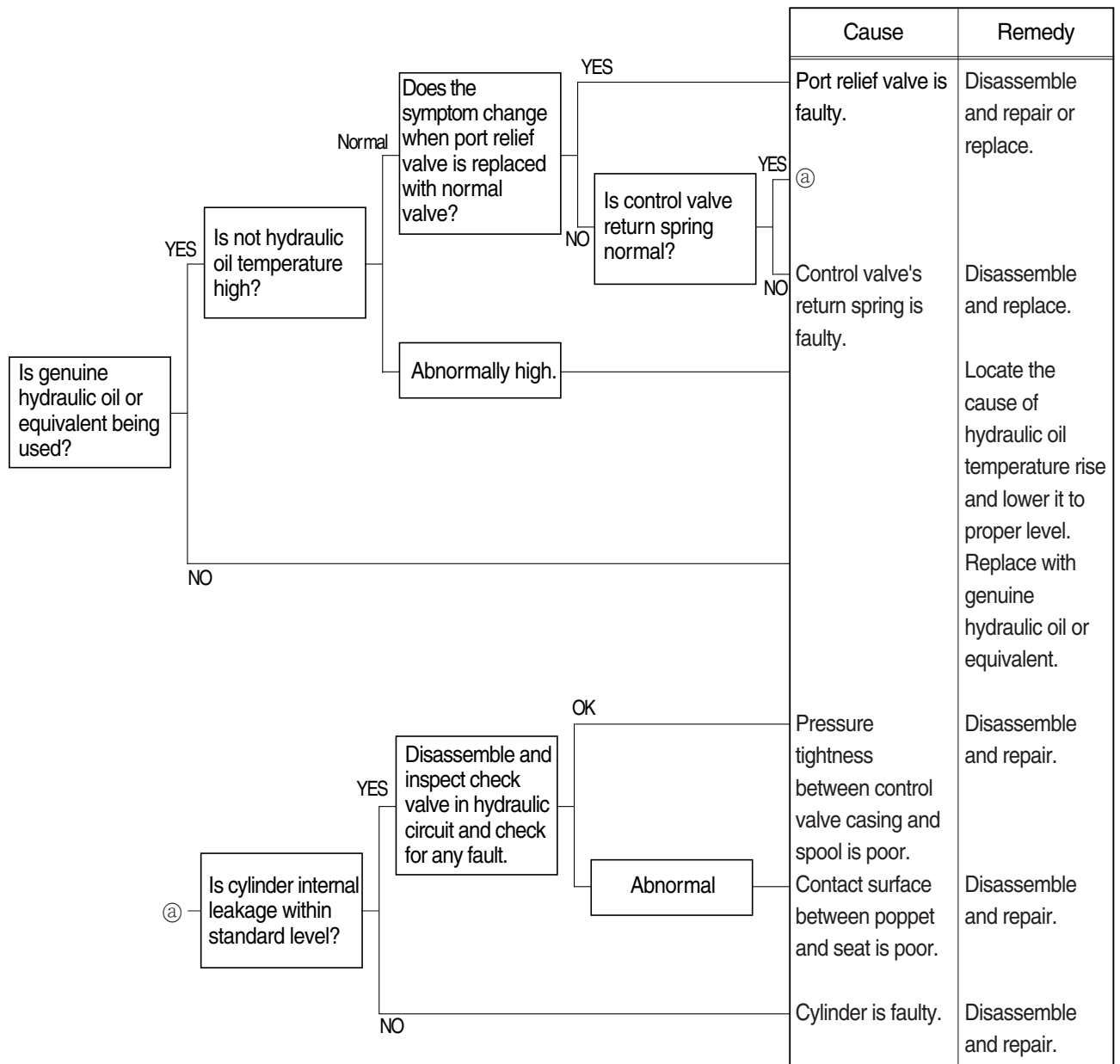

#### 4) BOOM, ARM OR BUCKET POWER IS WEAK

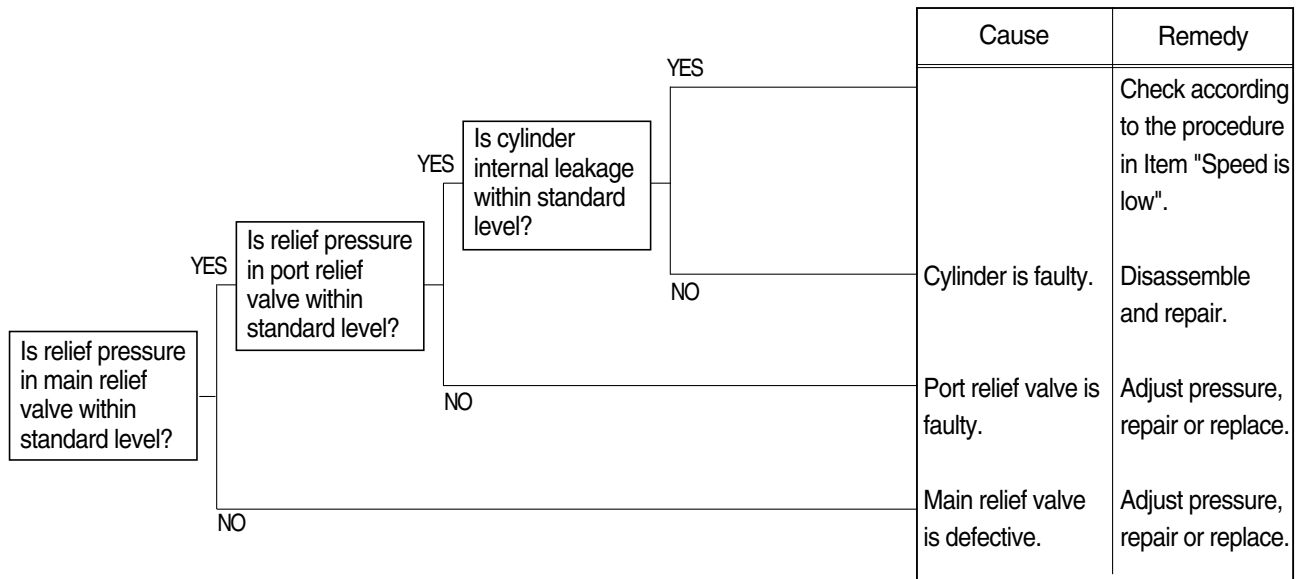

#### 5) ONLY BUCKET OPERATION IS TOTALLY IMPOSSIBLE

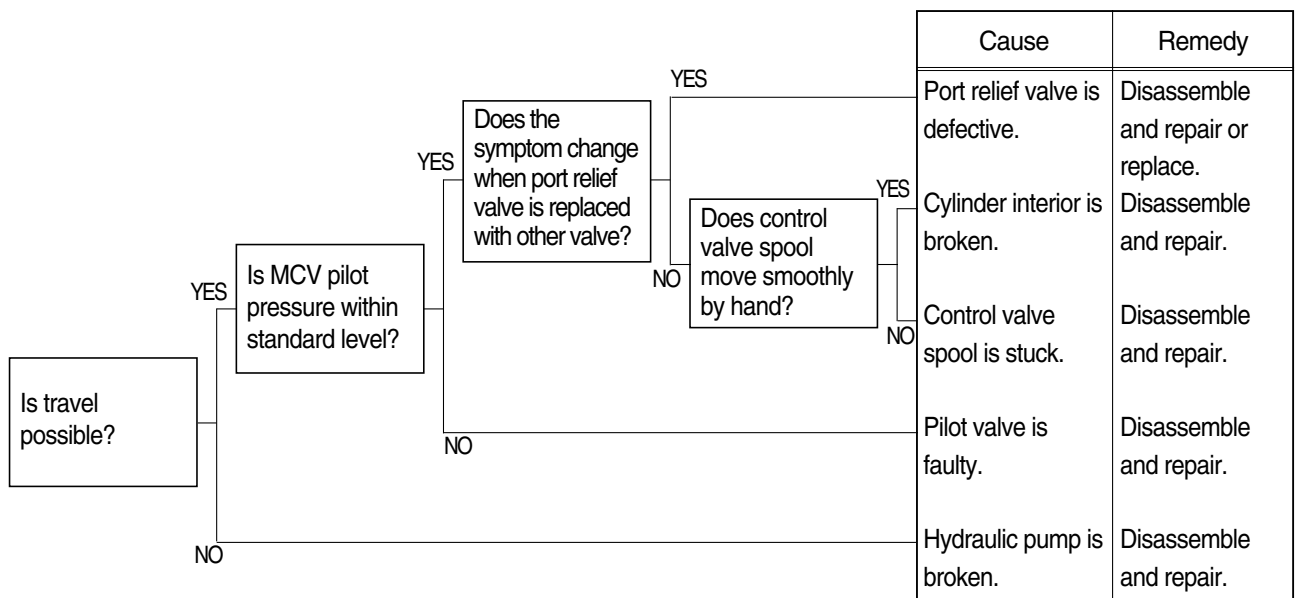

6) BOOM MAKES A SQUEAKING NOISE WHEN BOOM IS OPERATED

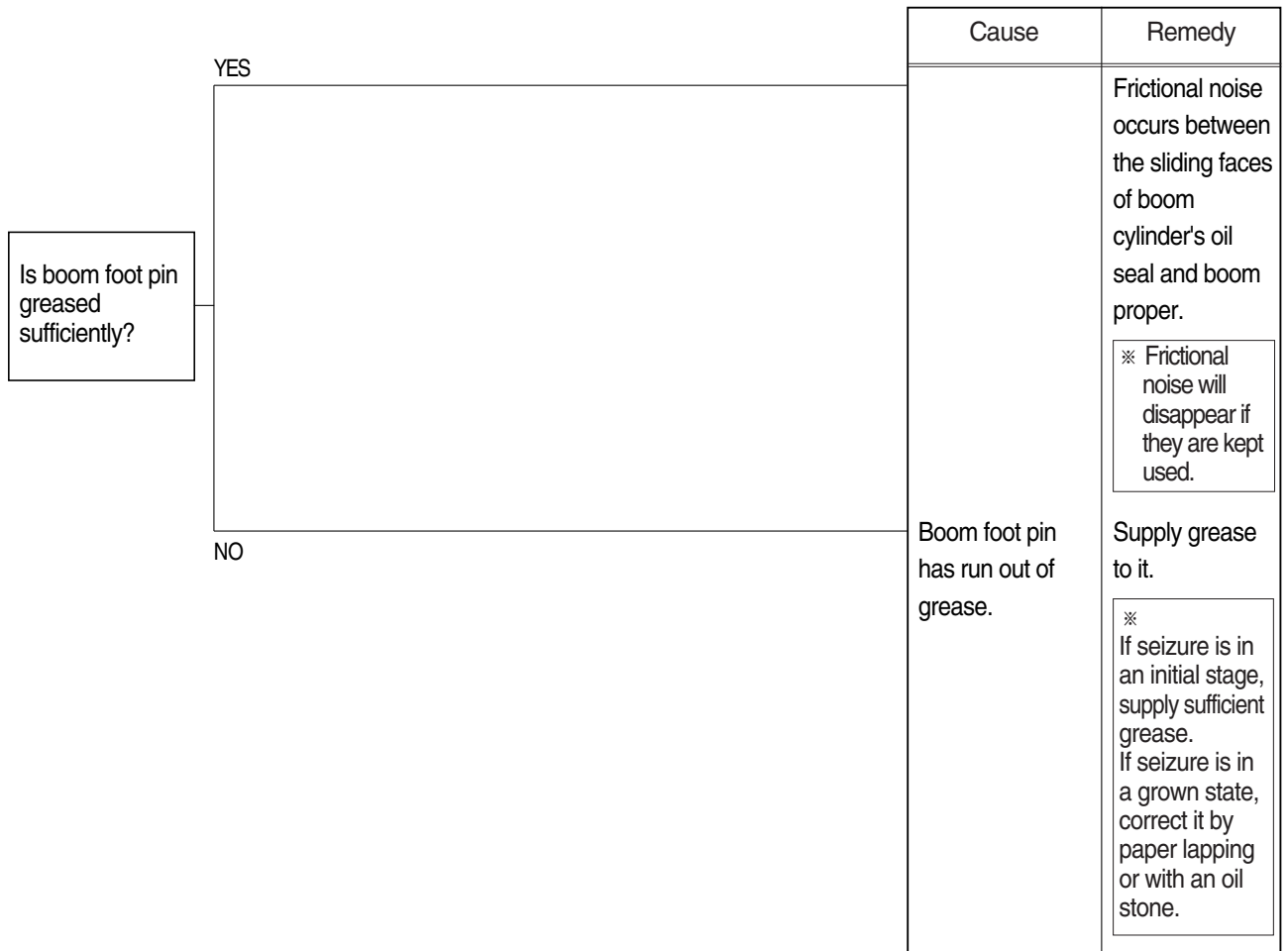

## ※ HOW TO CHECK INTERNAL BOOM CYLINDER LEAKAGE

1. Lower the bucket teeth to the ground with bucket cylinder fully retracted and arm cylinder rod retracted almost in full.

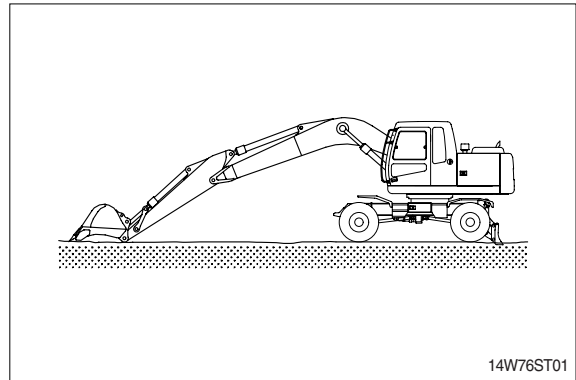

2. Disconnect hose(A) from rod side of boom cylinder and drain oil from cylinders and hose.(Put cups on piping and hose ends)

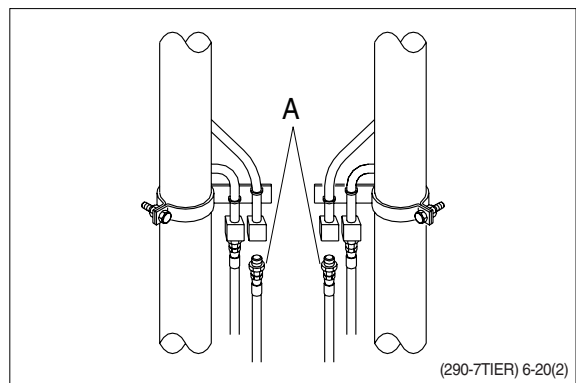

3. Raise bucket OFF the ground by retracting the arm cylinder rod.

If oil leaks from piping side and boom cylinder rod is retracted there is an internal leak in the cylinder.

If no oil leaks from piping side and boom cylinder rod is retracted, there is an internal leak in the control valve.

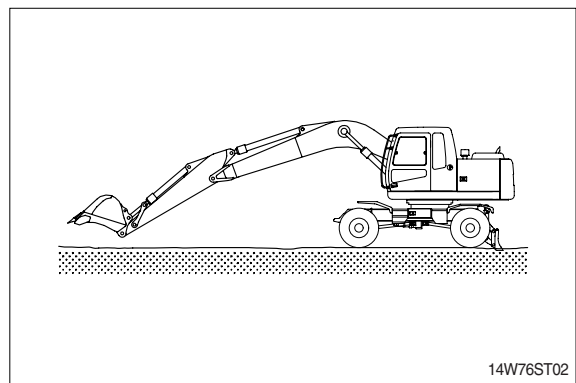

## 7. FRONT AXLE AND REAR AXLE

Problem	Cause	Correction
Insufficient braking	<p>1. Incorrect adjustment</p> <p>2. Brake discs worn out</p> <p>3. Incorrect brake fluid</p> <p>4. Loss of brake fluid</p> <p>5. Overheated axle causing brake fluid to vaporize. (Brake return when axle cools)</p>	<p>Inspect disc thickness and if discs are usable readjust brakes to the specifications in the manual.</p> <p>Inspect disc thickness and replace if necessary.</p> <p>Replace all seals in axle and master cylinder that have made contact with the incorrect fluid and all brake hoses. If incorrect fluid leaked into axle oil, seals and O-rings in axle must be replaced.</p> <p>Inspect for and repair any leaks in outside circuit or master cylinder. If caused by incorrect brake fluid see correction No.3. If leak is to the outside replace the O-rings between the center and intermediate housings. If leak is to the inside replace above O-rings and brake piston O-rings.</p> <p>See "overheating" problem.</p>
Soft brake pedal	6. Air in brake circuit	Bleed air in brake circuit.
Ineffective safety brake	<p>7. Incorrect adjustment</p> <p>8. Brake disc worn out</p>	<p>See correction No.1.</p> <p>See correction No.2.</p>
Overheating	<p>9. Oil level wrong</p> <p>10. Too small of a brake gap</p> <p>11. Park brake dragging</p> <p>12. Incorrect brake fluid in system</p> <p>13. No free-pedal at master cylinder</p> <p>14. Restriction in brake lines</p> <p>15. Restriction in return line of brake servo system</p> <p>16. Incorrect lubricant</p>	<p>Drain, flush and refill oil to proper level.</p> <p>Readjust brakes to the specifications.</p> <p>Unlock the brake and adjust the correct gap.</p> <p>See correction No.3.</p> <p>Readjust brake pedal.</p> <p>Inspect for and replace damage lines.</p> <p>Inspect for and replace damaged return line. Inspect for and remove any filter, tee'd in line or any other source of back pressure from the return line.</p> <p>Change the retaining rings of the brake circuit and brake pump.</p>
Diff-lock inoperative	<p>17. If manual control, loose or misadjusted linkage</p> <p>18. If hydraulic control, problems in the hydraulic or electrical circuits of the machine.</p> <p>19. If hydraulic control problems in actuating cylinder (noteable through loss of hydraulic oil or increase of the oil level in axle)</p> <p>20. If with limit slip differential, worn discs</p>	<p>Inspect and correct linkage and readjust.</p> <p>Refer to the hydraulic or electrical section in this manual.</p> <p>Rebuilt cylinder.</p> <p>Replace discs.</p>

Problem	Cause	Correction
Oil coming out of breather	21. Leak in internal brake system 22. Leak in diff-lock actuating cylinder	See correction No.2 and No.3. See correction No.19.
Nospin indexing noise when driving straight ※ With nospin, fatigue damage can occur on the side with the larger tire.	23. Unequal tire pressure left and right 24. Different style, size or brand of tires between left and right hand side	Inflate tires to the recommended pressure in this manual, or until the rolling radius is equal. Change tires to make the rolling radius equal. Vary the tire pressure within the specifications until the rolling radius is equal.
Noise during coast and under power the same	25. Wheel bearings damaged	Replace and adjust
Noise under power greater than during coast	26. Low oil level 27. Incorrect lubricant 28. Ring and pinion worn 29. Worn ring and pinion bearings 30. Worn planetary gears or bearings	Refill oil to proper level See correction No.16. Inspect through top cover. Replace and adjust. Replace and adjust Replace.
Noise during coast greater than under power	31. Loose pinion nut 32. Only pinion bearing damaged	Inspect ring, pinion and pinion bearings. If undamaged, retighten nut. See correction No.29.
Noise during turn (Without nospin)	33. Worn spider and/or side gears	Replace.
A stick slip noise when going from forward to reverse	34. Worn or damaged cardan shaft 35. Loose wheel 36. Articulation box joint and achsel shaft damaged 37. Spider pins loose in diff-carrier 38. Damaged or missing spider and/or side gear washers	Inspect and replace. Inspect for wheel and wheel stud damage. Replace if needed and retorque lugnuts. Inspect and replace. Inspect through top cover. Replace. See correction No.33.