

GROUP 4 SINGLE OPERATION

1. BOOM UP OPERATION

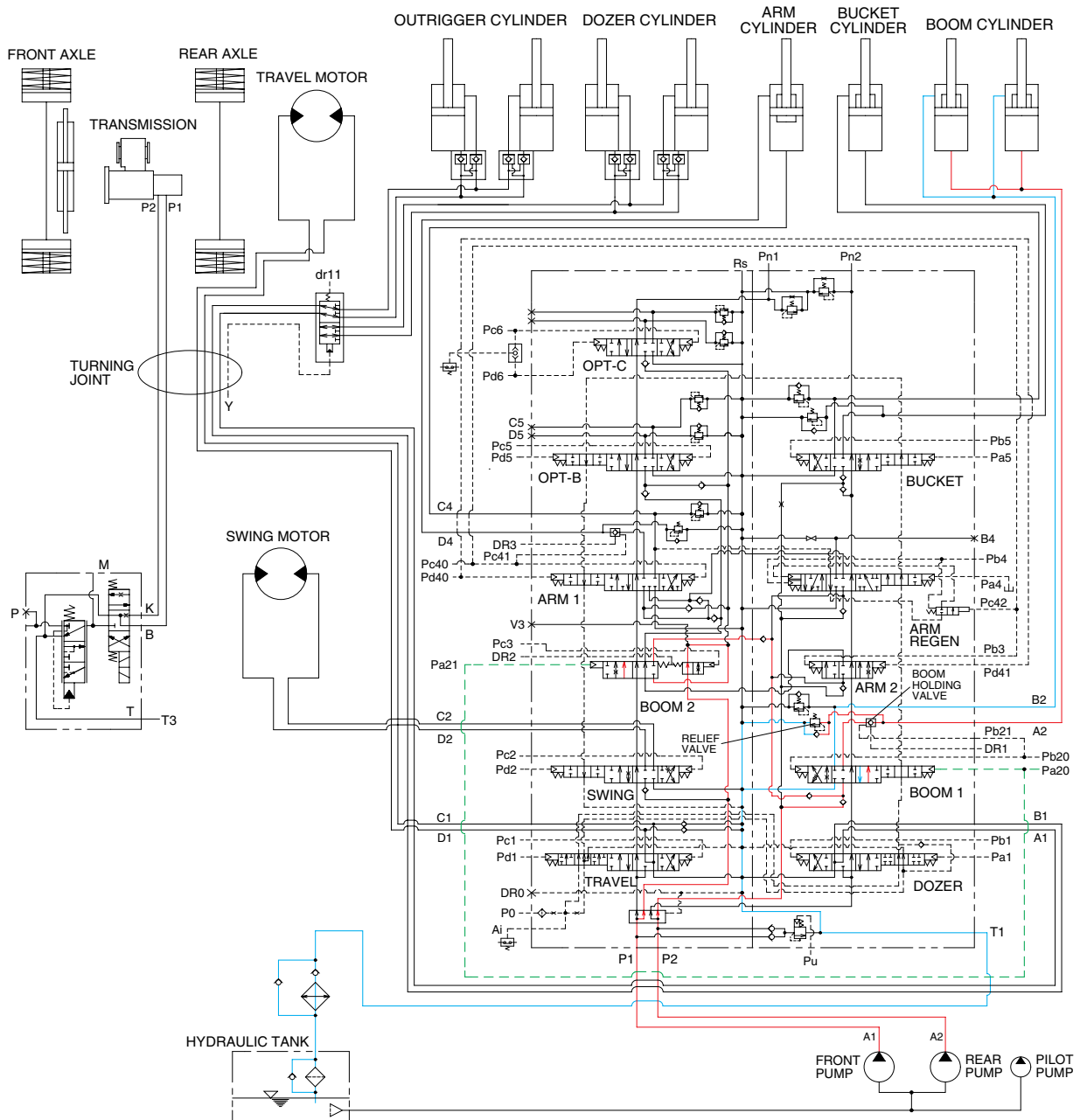

14W7A3HC10

When the right control lever is pulled back, the boom spools in the main control valve are moved to the up position by the pilot oil pressure from the remote control valve.

The oil from the front and rear pump flows into the main control valve and then goes to the large chamber of boom cylinders. At the same time, the oil from the small chamber of boom cylinders returns to the hydraulic oil tank through the boom spool in the main control valve. When this happens, the boom goes up. The excessive pressure in the boom cylinder bottom end circuit is prevented by relief valve. When the boom is up and the control lever is returned to neutral position, the circuit for the holding pressure at the bottom end of the boom cylinder is closed by the boom holding valve. This prevents the hydraulic drift of boom cylinder.

2. BOOM DOWN OPERATION

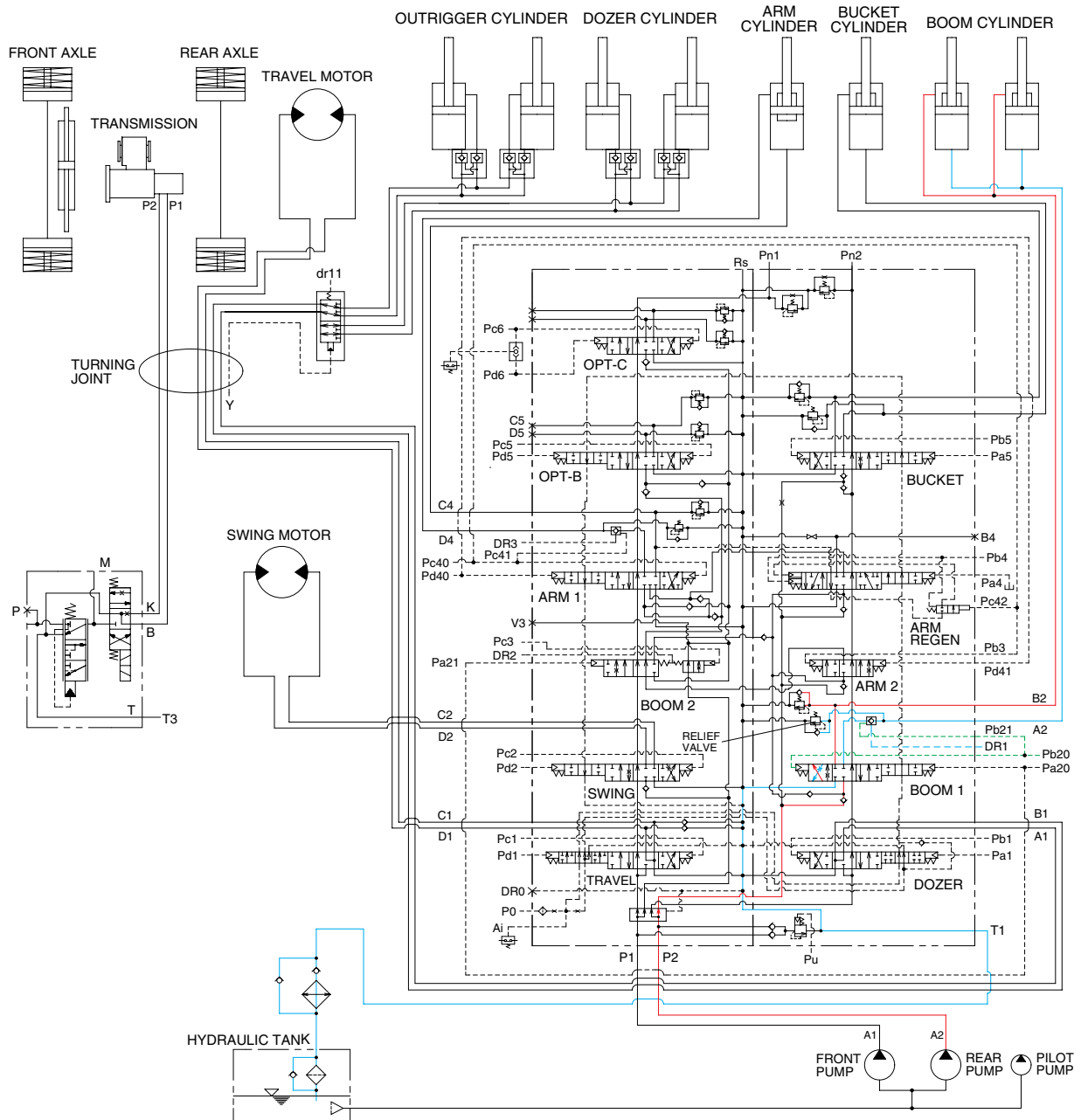

14W7A3HC11

When the right control lever is pushed forward, the boom spools in the main control valve are moved to the down position by the pilot oil pressure from the remote control valve.

The oil from the rear pump flows into the main control valve and then goes to the small chamber of boom cylinders. At the same time, the oil from the large chamber of boom cylinders returns to the hydraulic tank through the boom spool in the main control valve.

When the down speed of boom is faster, the oil returned from the large chamber of boom cylinder combines with the oil from the rear pump, and flows into the small chamber of the cylinder.

This prevents cylinder cavitation by the negative pressure when the rear pump flow can not match the boom down speed. And the excessive pressure in the boom cylinder rod end circuit is prevented by the relief valve.

3. ARM ROLL IN OPERATION

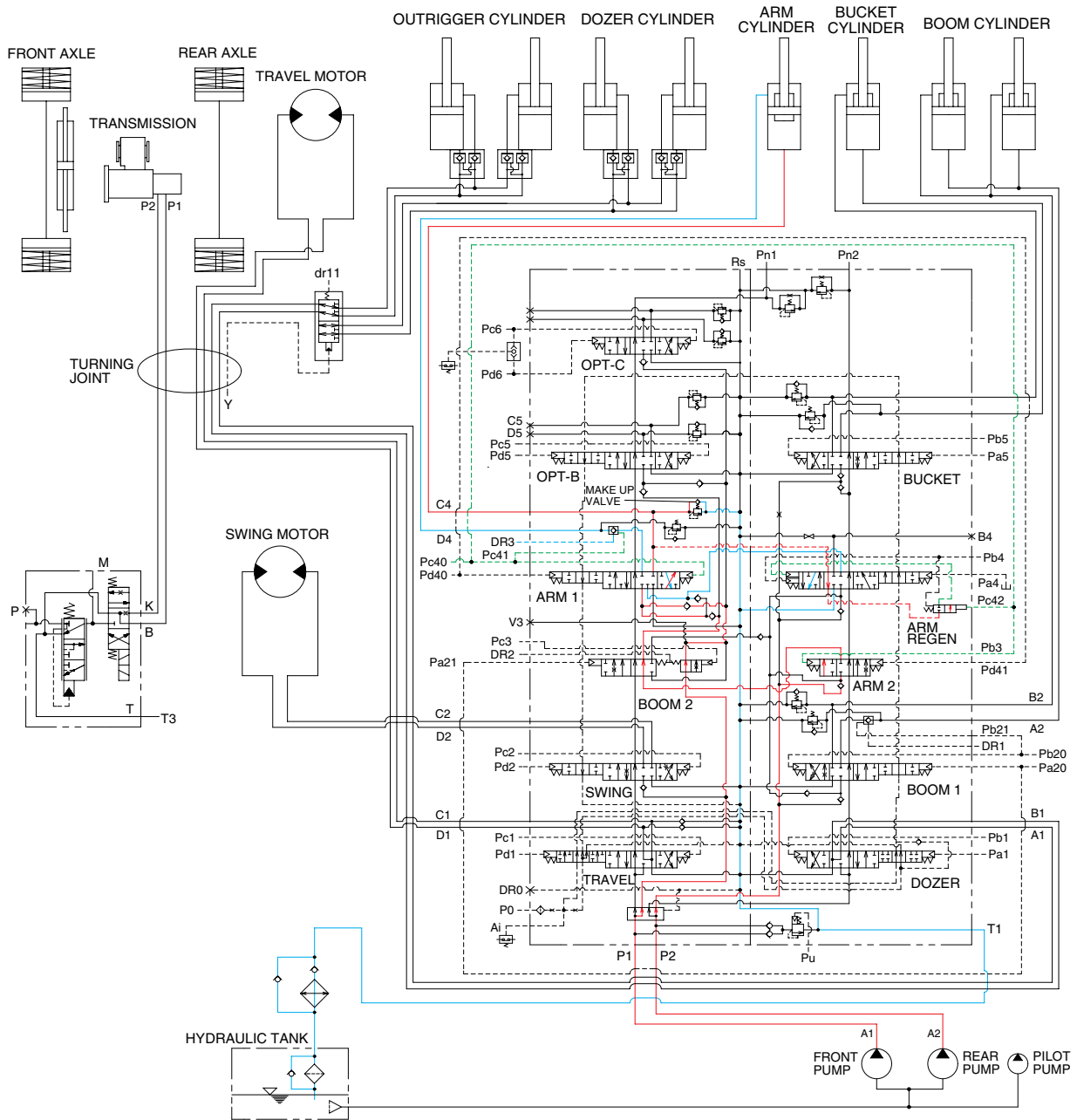

14W7A3HC12

When the left control lever is pulled back, the arm spools in the main control valve are moved to the roll in position by the pilot oil pressure from the remote control valve.

The oil from the front and rear pump flows into the main control valve and then goes to the large chamber of arm cylinder.

At the same time, the oil from small chamber of arm cylinder returns to the hydraulic oil tank through the arm spool in the main control valve. When this happens, the arm rolls in.

The cavitation which will happen to the bottom of the arm cylinder is also prevented by the make-up valve in the main control valve.

4. ARM ROLL OUT OPERATION

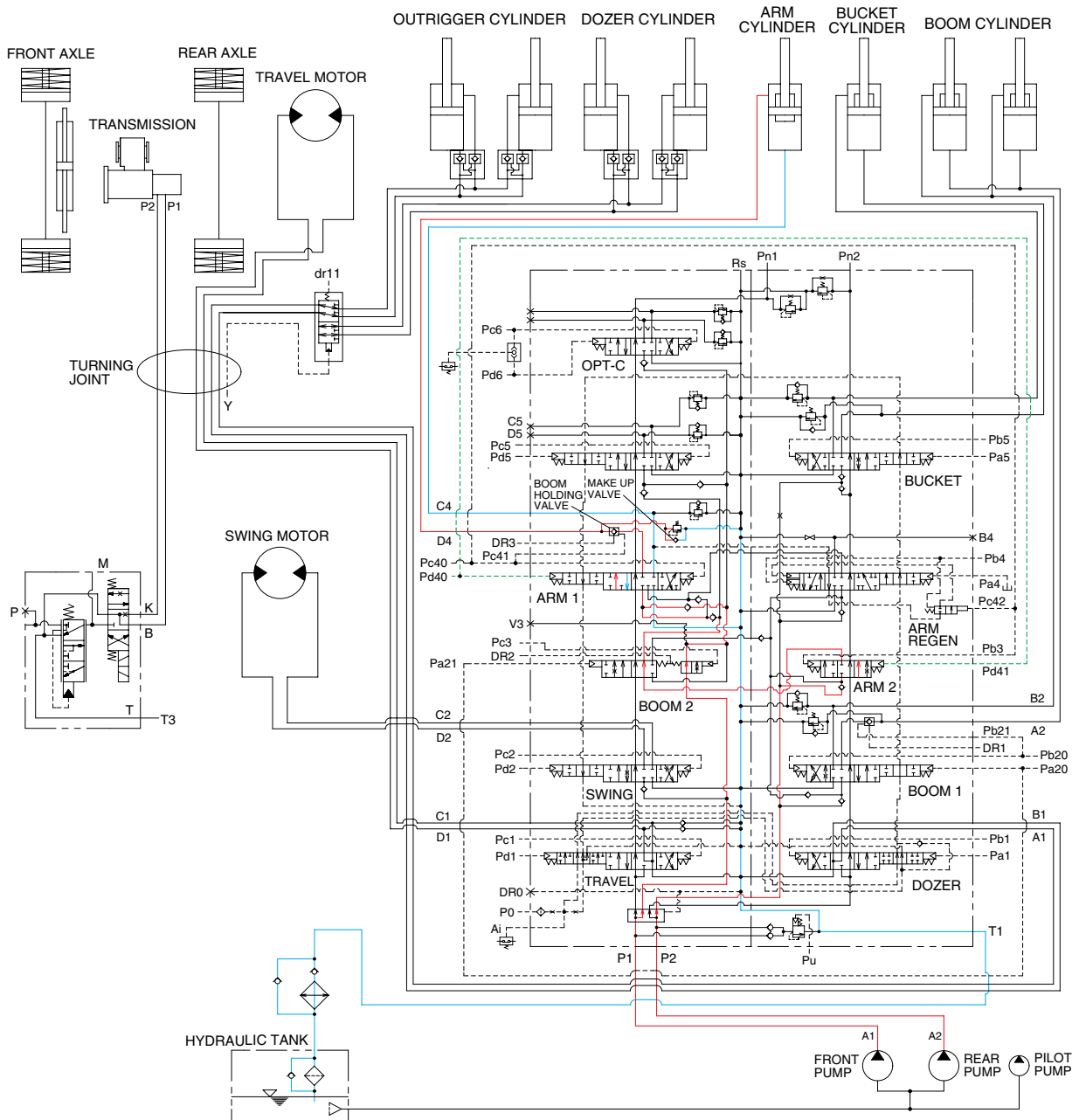

14W7A3HC13

When the left control lever is pushed forward, the arm spool in the main control valve are moved to the roll out position by the pilot oil pressure from the remote control valve.

The oil from the front and rear pump flows into the main control valve and then goes to the small chamber of arm cylinder. At the same time, the oil from the large chamber of arm cylinder returns to the hydraulic oil tank through the arm spool in the main control valve. When this happens, the arm rolls out. The cavitation which will happen to the rod of the arm cylinder is also prevented by the make-up valve in the main control valve. When the arm is roll out and the control lever is returned to neutral position, the circuit for the holding pressure at the rod end of the arm cylinder is closed by the arm holding valve. This prevent the hydraulic drift of arm cylinder.

5. BUCKET ROLL IN OPERATION

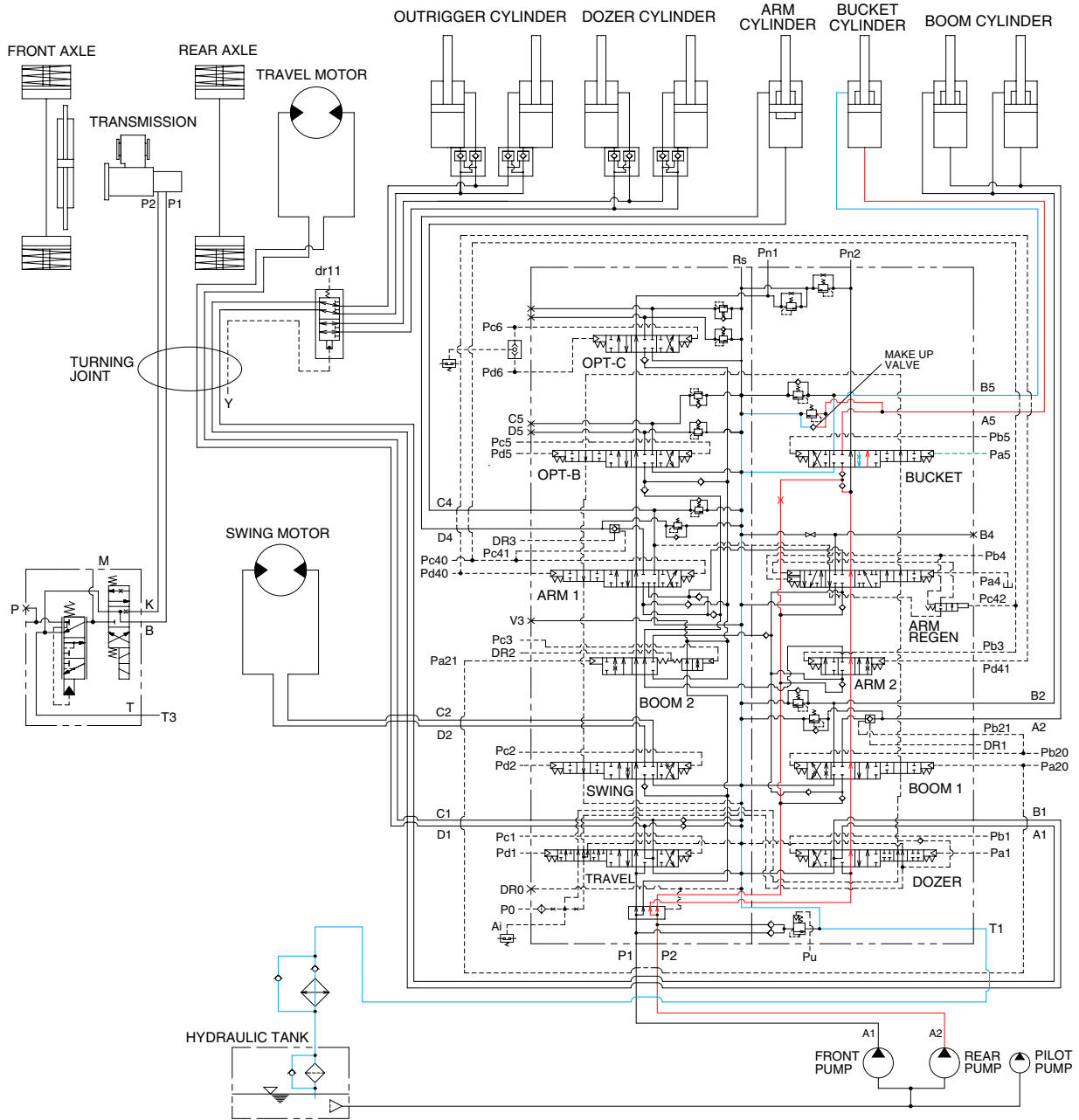

14W7A3HC14

When the right control lever is pulled left, the bucket spool in the main control valve is moved to the roll in position by the pilot oil pressure from the remote control valve.

The oil from the rear pump flows into the main control valve and then goes to the large chamber of bucket cylinder.

At the same time, the oil from the small chamber of bucket cylinder returns to the hydraulic oil tank through the bucket spool in the main control valve. When this happens, the bucket rolls in.

The cavitation which will happen to the bottom of the bucket cylinder is also prevented by the make-up valve in the main control valve.

6. BUCKET ROLL OUT OPERATION

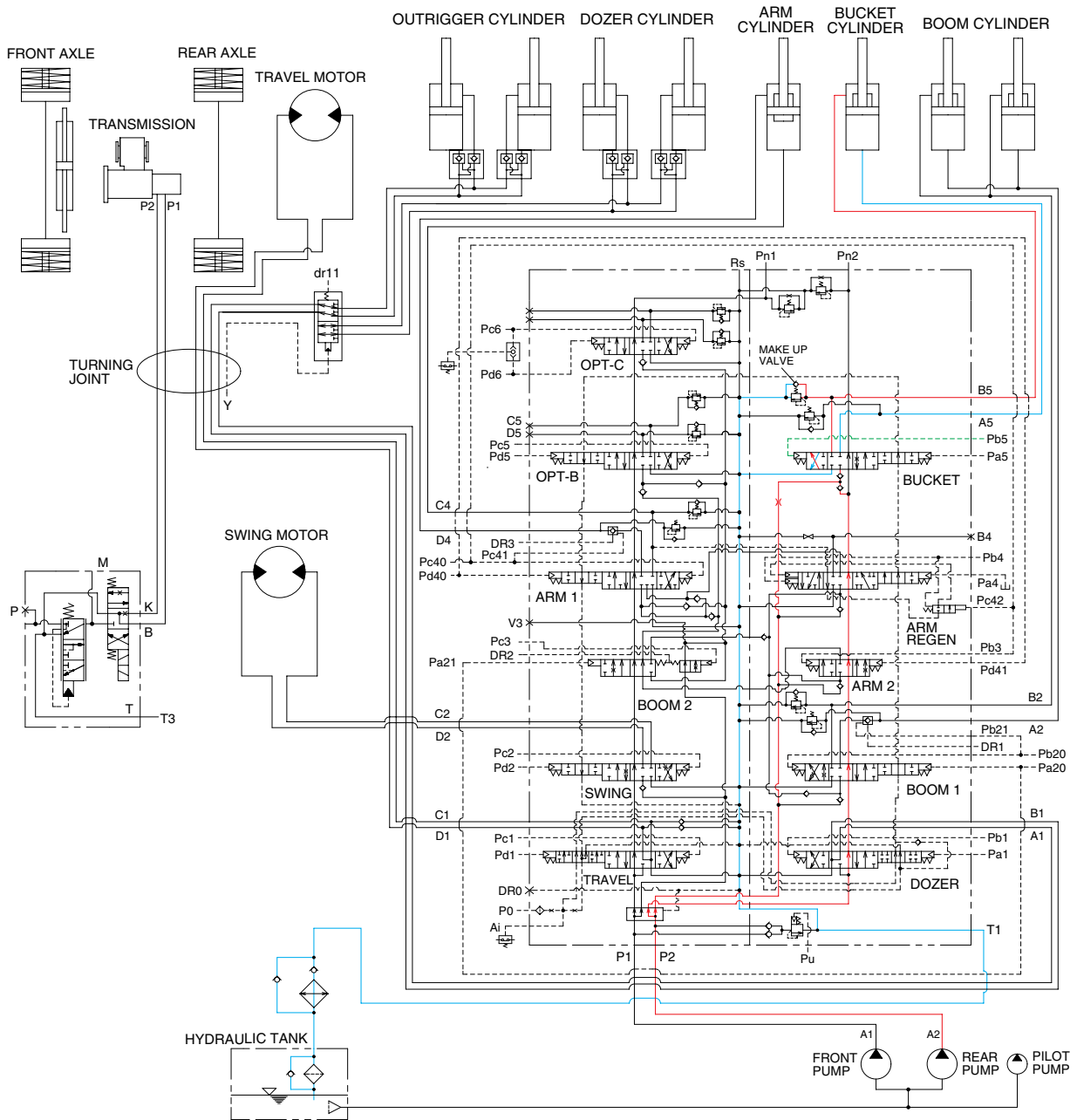

14W7A3HC15

When the right control lever is pushed right, the bucket spool in the main control valve is moved to the roll out position by the pilot oil pressure from the remote control valve.

The oil from the rear pump flows into the main control valve and then goes to the small chamber of bucket cylinder.

At the same time, the oil from the large chamber of bucket cylinder returns to the hydraulic oil tank through the bucket spool in the main control valve. When this happens, the bucket rolls out.

The cavitation which will happen to the rod of the bucket cylinder is also prevented by the make-up valve in the main control valve.

7. DOZER/OUTRIGGER UP OPERATION

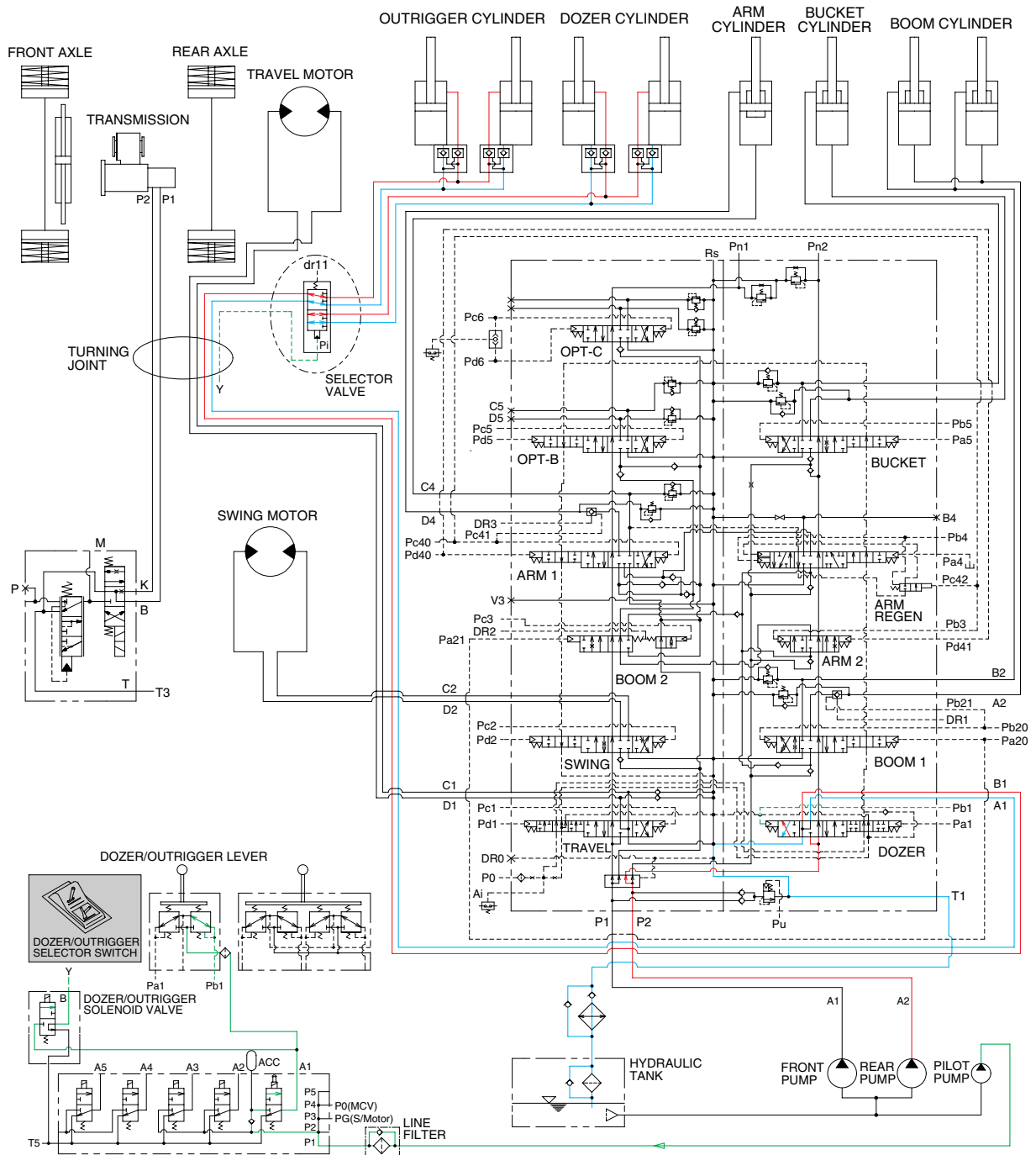

14W7A3HC16

When the dozer control lever is pulled back, the dozer spool in the main control valve is moved to the dozer up position by the pilot oil pressure from the remote control valve. The oil from the rear pump flows into the main control valve and then goes to the selector valve. Then, the selector switch on the switch panel is selected to rear actuator position, the oil from the main control valve flows into the small chamber of rear actuator cylinder (dozer or outrigger). The other case, the oil flows into the small chamber of front actuator cylinder (dozer or outrigger). At the same time, the oil from the large chamber of dozer (outrigger) cylinders returns to the hydraulic oil tank through the dozer spool in the main control valve. When this happens, the dozer (outrigger) goes up.

8. DOZER/OUTRIGGER DOWN OPERATION

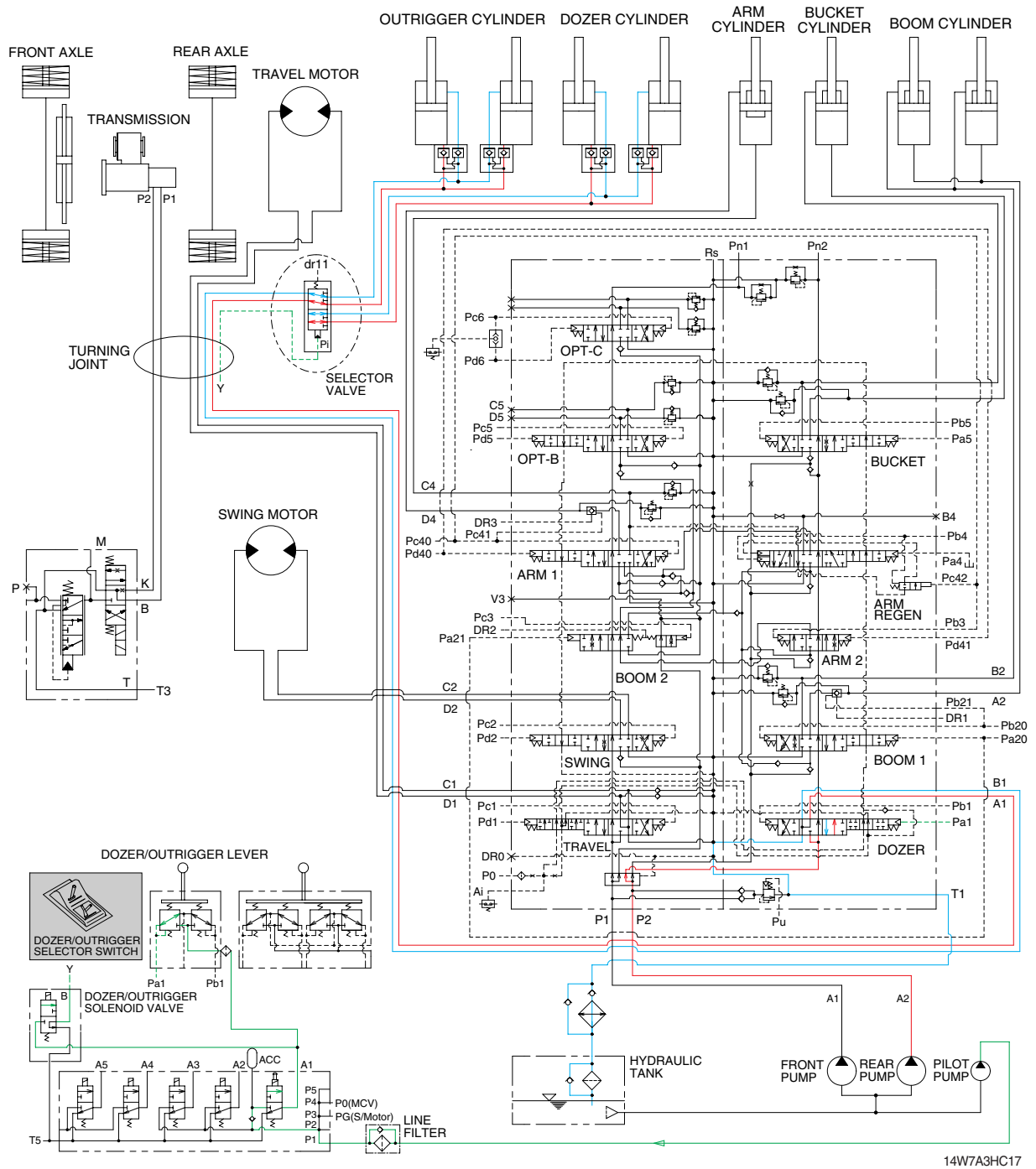

14W7A3HC17

When the dozer control lever is pushed forward, the dozer spool in the main control valve is moved to the dozer down position by the pilot oil pressure from the remote control valve. The oil from the rear pump flows into the main control valve and then goes to the selector valve. Then, the selector switch on the switch panel is selected to rear actuator position, the oil from the main control valve flows into the large chamber of rear actuator cylinder (dozer or outrigger). The other case, the oil flows into the large chamber of front actuator cylinder (dozer or outrigger). At the same time, the oil from the small chamber of dozer (outrigger) cylinders returns to the hydraulic oil tank through the dozer spool in the main control valve. When this happens, the dozer (outrigger) goes down.

9. SWING OPERATION

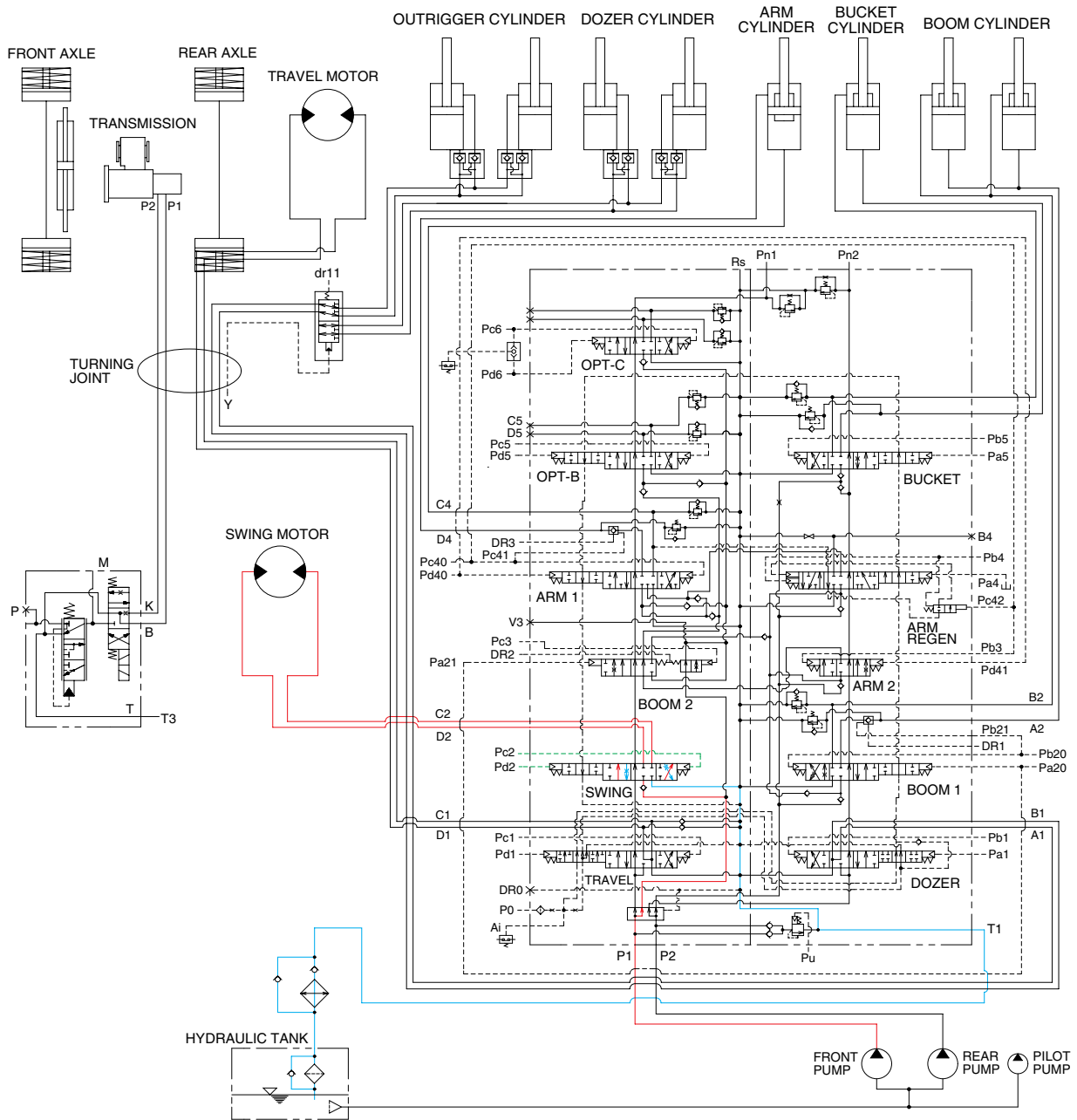

14W7A3HC18

When the left control lever is pushed left or right, the swing spool in the main control valve is moved to the left or right swing position by the pilot oil pressure from the remote control valve.

The oil from the front pump flows into the main control valve and then goes to the swing motor.

At the same time, the return oil from the swing motor returns to the hydraulic oil tank through the swing spool in the main control valve.

When this happens, the superstructure swings to the left or right.

The swing parking brake, make up valve and the overload relief valve are provided in the swing motor. The cavitation which will happen to the swing motor is also prevented by the make up valve in the swing motor itself.

SWING CIRCUIT OPERATION

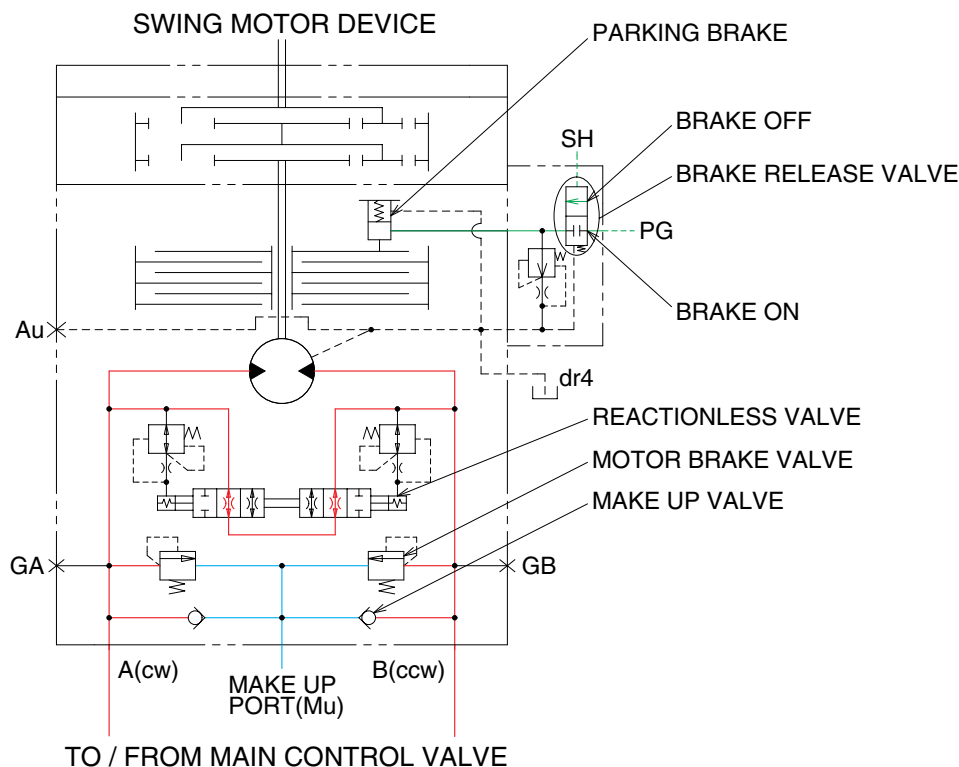

14W7A3HC18A

1) MOTOR BRAKE VALVE

Motor brake valve for the swing motor limits to cushion the starting and stopping pressure of swing operation.

2) MAKE UP VALVE

The make up valves prevent cavitation by supplying return oil to the vacuum side of the motor.

3) PARKING BRAKE

In case that the parking, of the machine at slope is required during operation, there is the danger of involuntary swing caused by the self weight of the machine. The brake is connected to prevent this involuntary swing.

PARKING BRAKE "OFF" OPERATION

The parking brake is released by the pilot pressure oil from the pilot pump.

When the left control lever placed in the swing position, the pilot pressure at the shuttle valve is transferred to the brake release valve and the brake release valve is change over. Then the pilot pressure lift the brake piston and release the parking brake.

PARKING BRAKE "ON" OPERATION

When the control lever placed in the neutral position, the pressure of the pilot oil passage down.

Then the brake release valve returned to the neutral position and the oil is returned from the brake piston to the tank. And the brake is set to 'ON'.

4) REACTIONLESS VALVE

This reactionless valve absorbs shocks produced as swing motion stops and reduces oscillation cause by swing motion.

10. TRAVEL FORWARD AND REVERSE OPERATION

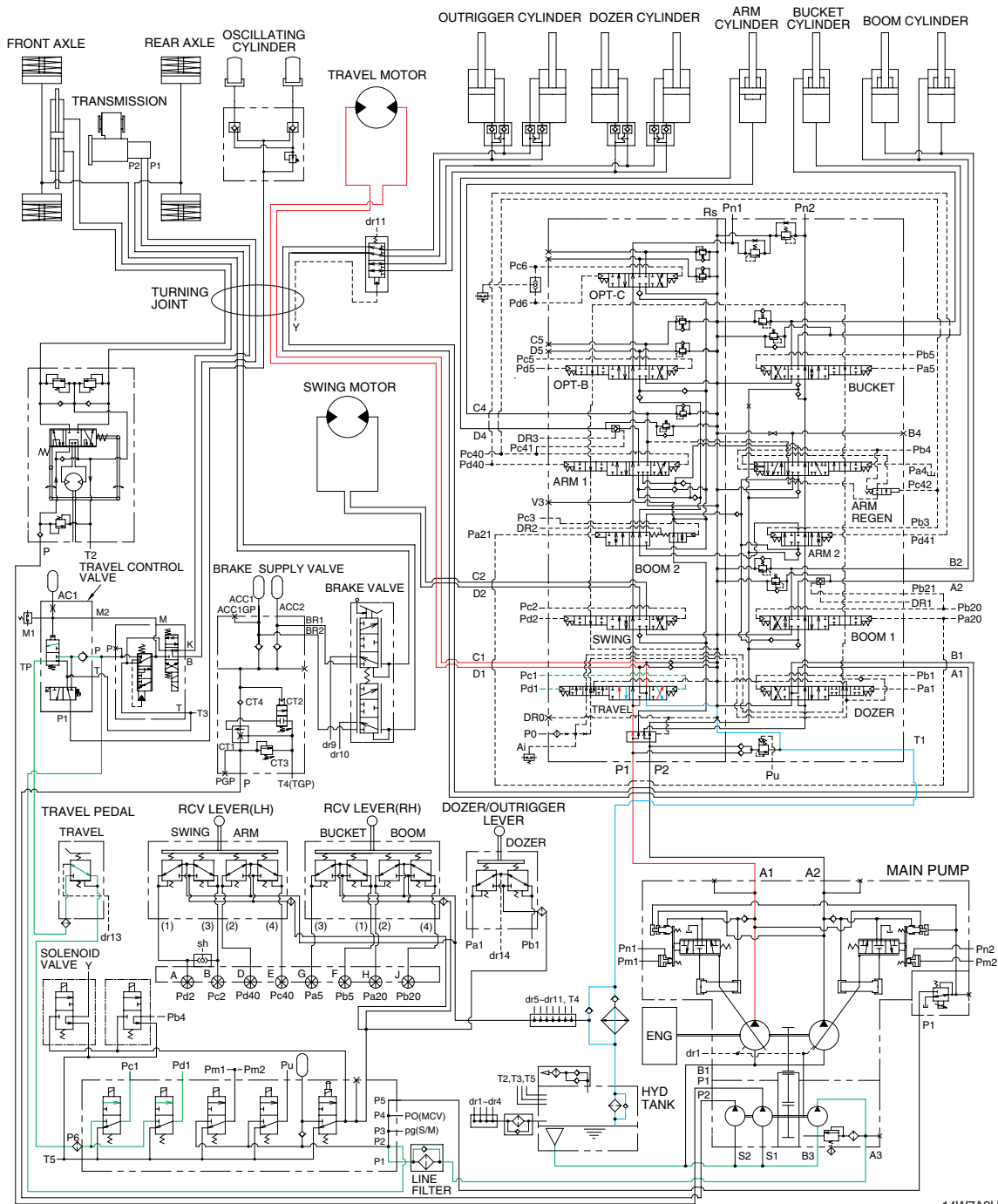

14W7A3HC19

When the RH multifunction switch is placed in forward or reverse position, the travel spool in the main control valve is moved to the forward or reverse position by the pilot oil pressure from pilot pump through the travel pilot solenoid of travel control valve and travel Forward/Reverse solenoid valve. The oil from the front pump flows into the main control valve and then goes to the travel motor. At the same time, the oil returned from the travel motor returns to the hydraulic oil tank through the turning joint and travel spool in the main control valve.

When this happens, the machine moves forward or reverse.

The cavitation which will happen to the travel motor is prevented by the make-up valve in the main control valve.

TRAVEL CIRCUIT OPERATION

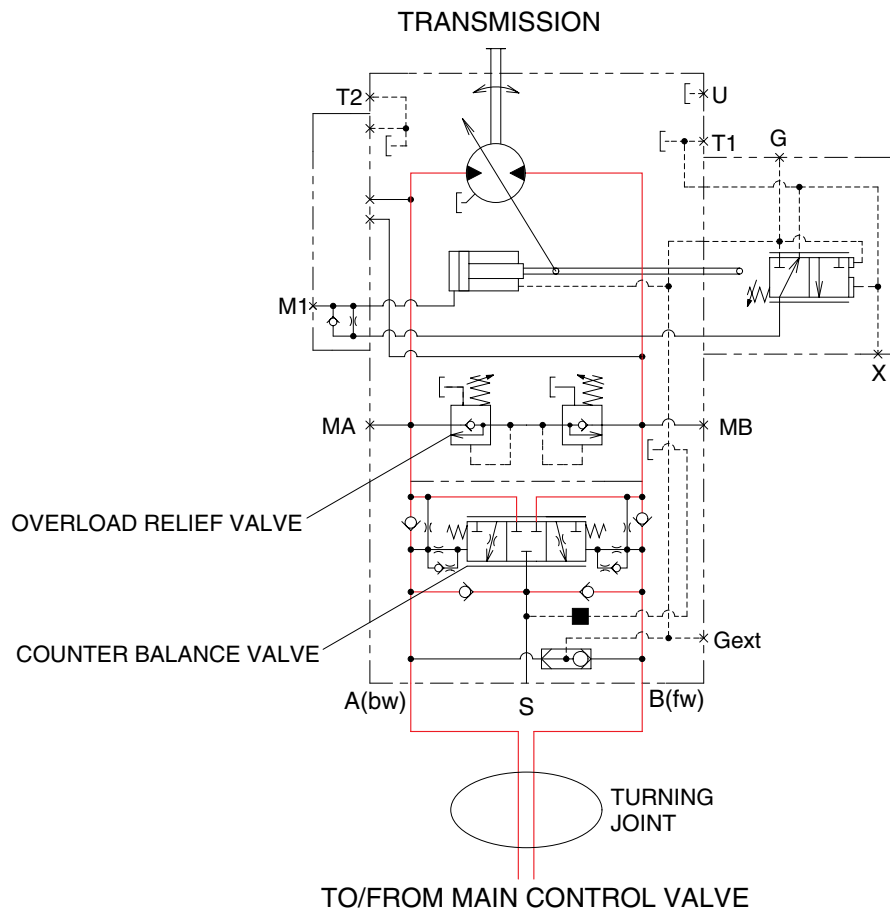

14W7A3HC19A

Valves are provided on travel motor to offer the following functions.

1) COUNTER BALANCE VALVE

When stopping the motor on a slope descending, this valve prevents the motor from over running.

2) OVERLOAD RELIEF VALVE

Relief valve limits the circuit pressure below 390kgf/cm^2 to prevent high pressure from being generated at the time of stopping the machine. When stopping the motor, this valve sucks the oil from lower pressure passage for preventing the negative pressure and the cavitation of the motor.

11. FRONT AND REAR AXLE BRAKE SYSTEM(SERVICE BRAKE)

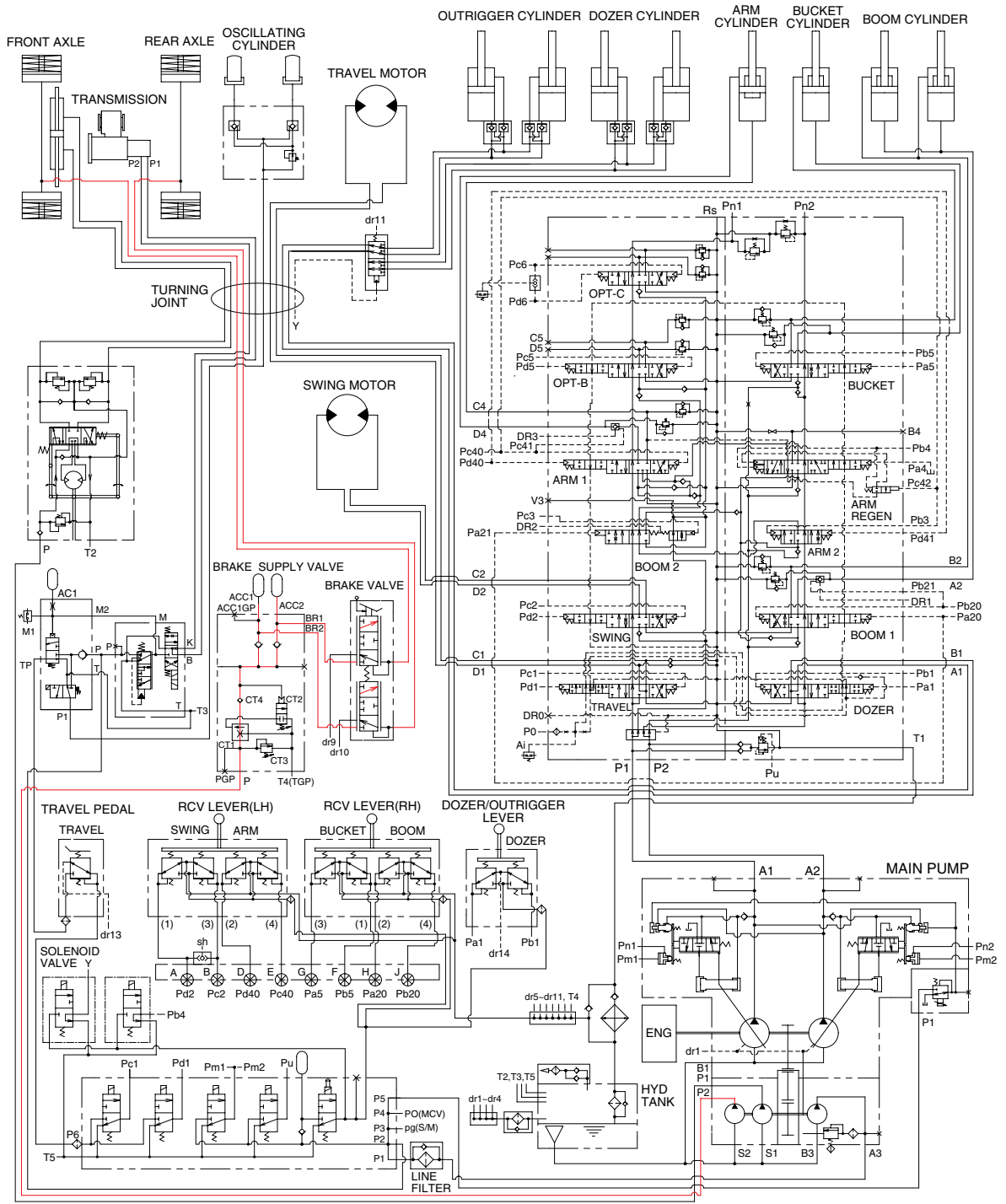

14W7A3HC20

When the brake pedal (Valve) is pushed, the discharged oil from the gear pump (P2) flows into the front and rear axle brake disc through the solenoid valve of brake supply valve. This pressure is applied to axle brake disc, thus the brake is applied.

12. STEERING CIRCUIT OPERATION

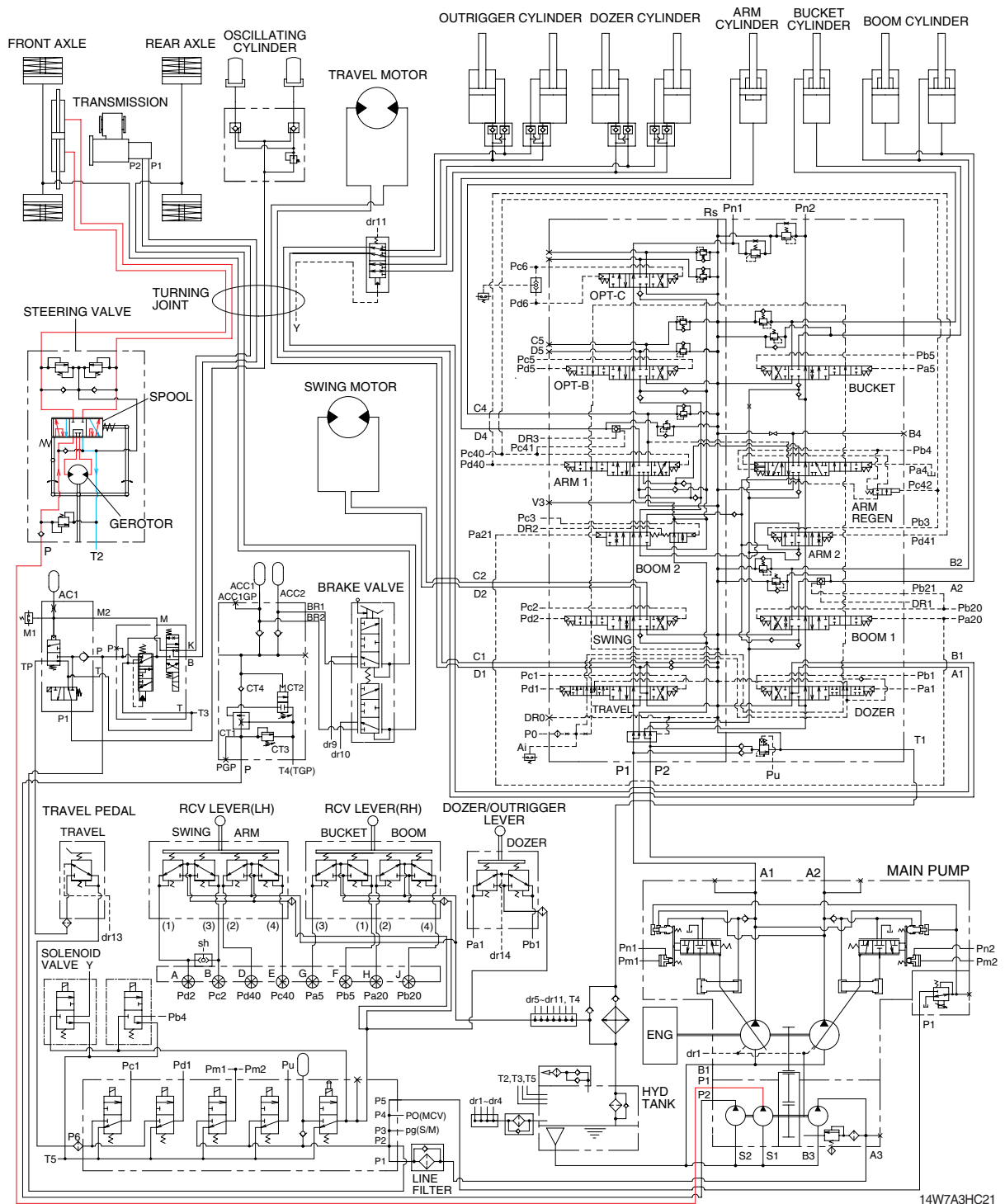

When the steering wheel is turned to the left or right, the spool within the steering valve turns left or right hand direction : Because the spool is connected with steering column.
 At this time, the oil discharged from the gear pump (P1) flows into steering cylinder through spool and gerotor within the steering valve.
 Then the steering direction is applied.

13. RAM LOCK CIRCUIT OPERATION

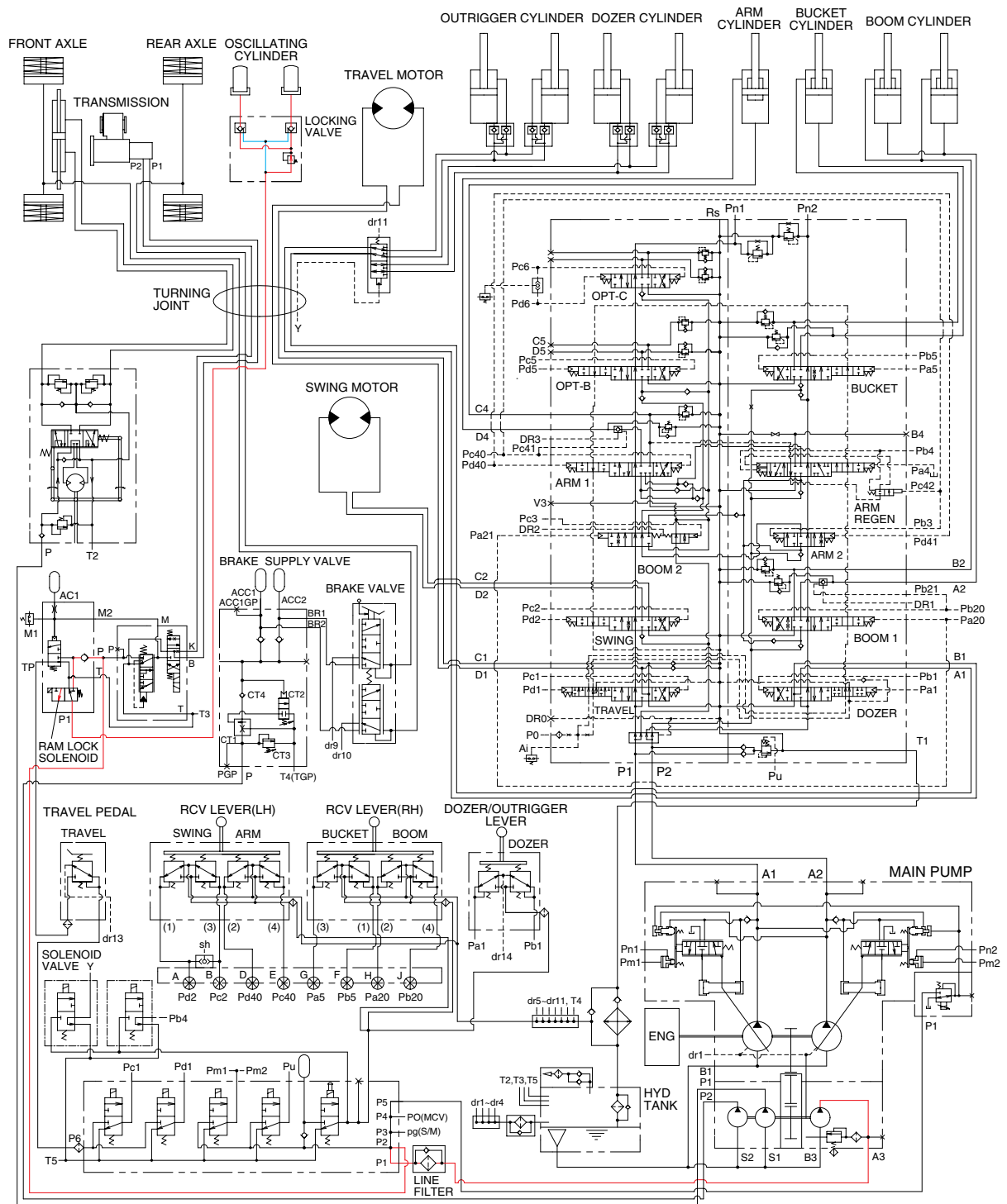

14W7A3HC22

When the ram lock switch is selected on the switch panel, the ram lock solenoid is changed over. Thus, the oil discharged from the pilot pump flows into oscillating cylinder through ram lock solenoid and locking valve. This pressure is applied to check valve and oscillating cylinder, thus the oscillating function is operated (Ram lock released).