

GROUP 2 MAIN CONTROL VALVE

1. STRUCTURE

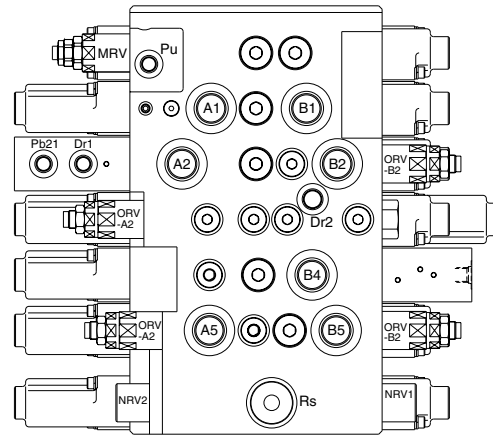

VIEW A

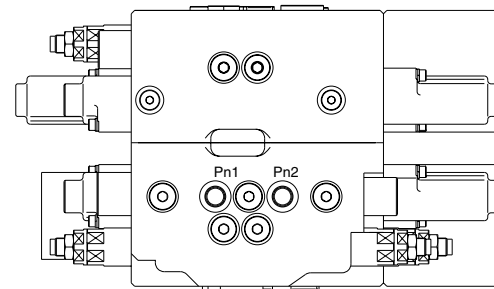
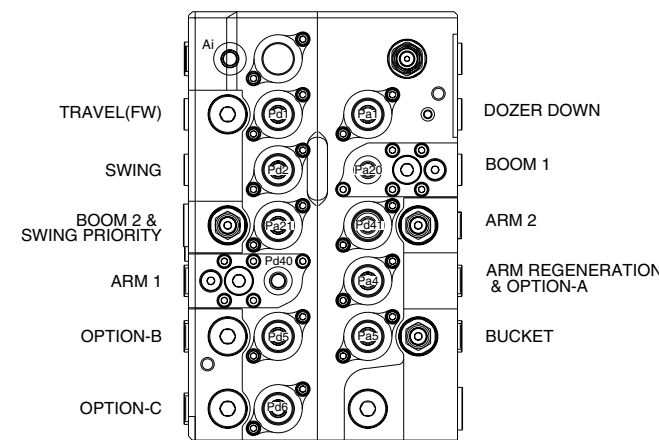
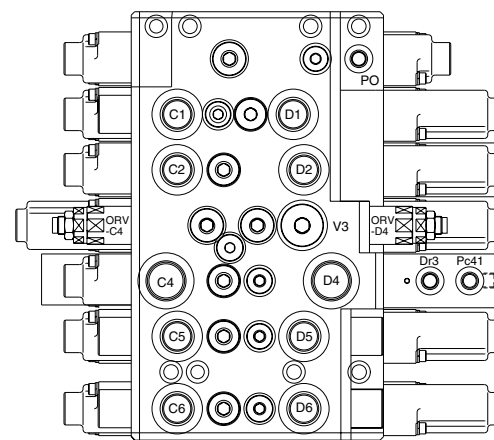
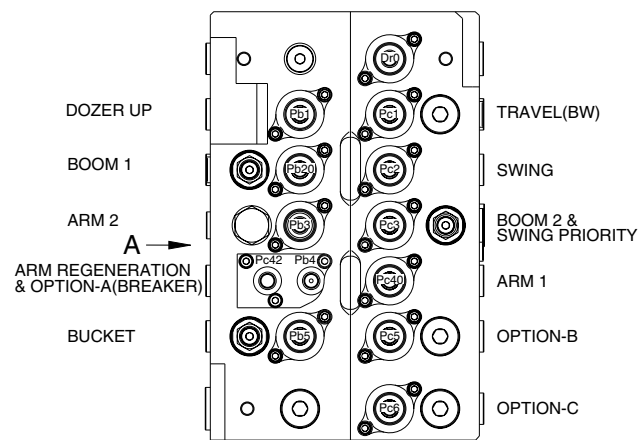
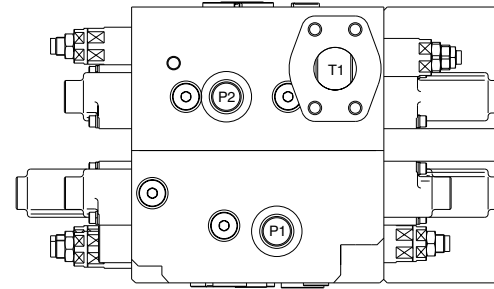

Mark	Port name	Port size	Tightening torque		
Rs	Make up for swing motor	PF1/4	3.5~3.9kgf · m (25.3~28.2lbf · ft)		
Pa1	Dozer down pilot port				
Pb1	Dozer up pilot port				
Pc1	Travel pilot port(BW)				
Pd1	Travel pilot port(FW)				
Pa20	Boom up pilot port				
Pa21	Boom up confluence pilot port				
Pb20	Boom down pilot port				
Pb21	Lock valve pilot port(Boom)				
Pc2	Swing pilot port(RH)				
Pd2	Swing pilot port(LH)				
Pb3	Arm in confluence pilot port				
Pc3	Swing priority pilot port				
Pa4	Option A pilot port(Breaker)				
Pb4	Arm in regeneration cut port				
Pc40	Arm in pilot port				
Pc41	Lock valve pilot port(Arm)				
Pc42	Arm in regen-cut signal selector port				
Pd40	Arm out pilot port				
Pd41	Arm out confluence pilot port				
Pa5	Bucket in pilot port				
Pb5	Bucket out pilot port				
Pc5	Option B pilot port				
Pd5	Option B pilot port				
Pc6	Option C pilot port				
Pd6	Option C pilot port				
P0	Pilot pressure port	PF3/8	-		
Pu	Main relief pressure up				
Ai	Auto idle signal port	PF3/4	15~18kgf · m (109~130lbf · ft)		
Dr0	Drain port(Travel straight)				
Dr1	Drain port(Boom holding valve)				
Dr2	Drain port(Boom2 & swing priority)				
Dr3	Drain port(Arm holding valve)				
Pn1	Negative control signal port(P1 port side)			PF3/8	-
Pn2	Negative control signal port(P2 port side)				
A1	Dozer down port			PF3/4	15~18kgf · m (109~130lbf · ft)
B1	Dozer up port				
C1	Travel motor port(BW)				
D1	Travel motor port(FW)				
B2	Boom rod side port				
C2	Swing motor port(RH)				
D2	Swing motor port(LH)				
B4	Option A port(Breaker)				
A5	Bucket head side port				
B5	Bucket rod side port				
C5	Option B port				
D5	Option B port				
C6	Option C port				
D6	Option C port				
P1	Pump port(P1 side)	PF1	20~25kgf · m (115~180lbf · ft)		
P2	Pump port(P2 side)				
A2	Boom head side port				
C4	Arm head side port	PF1	20~25kgf · m (115~180lbf · ft)		
D4	Arm rod side port				
T1	Return port	SAE3000, 1 1/2 (M12 × 1.75)	8.5~11.5kgf · m (61.5~83.1lbf · ft)		

14W7A2MC01

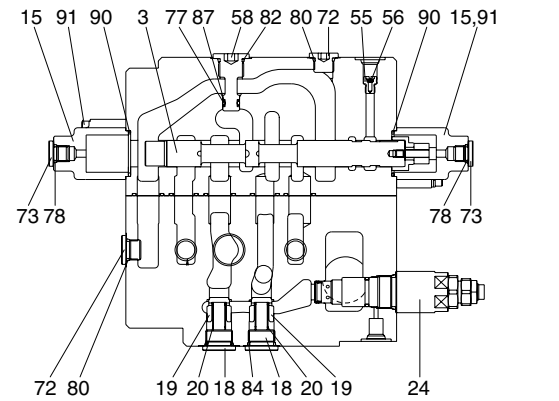

A - A (STRAIGHT-TRAVEL & SUPPLY)

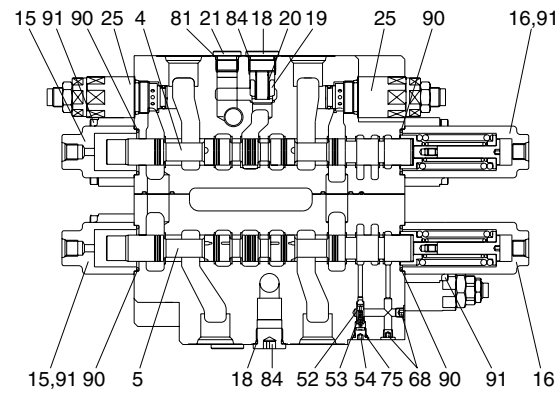

B - B (TRAVEL & DOZER)

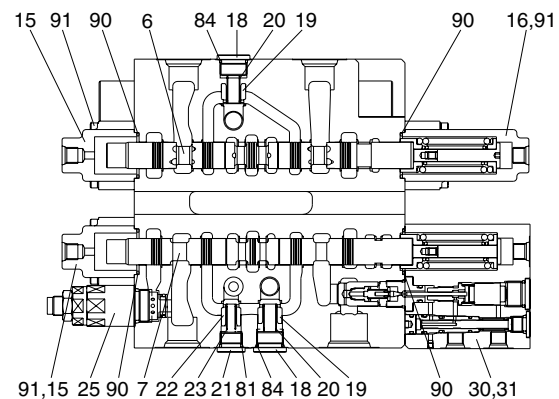

C - C (SWING & BOOM)

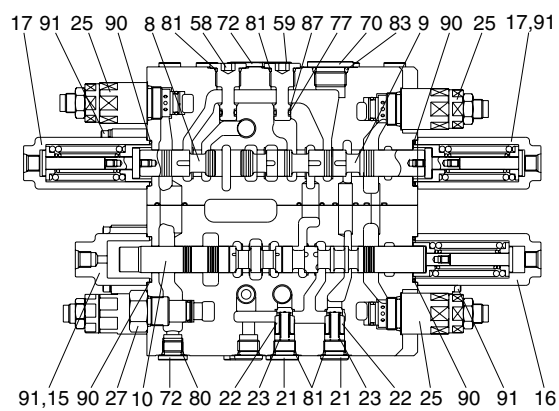

D - D (SWING PRIORITY & BOOM 2 & ARM 2)

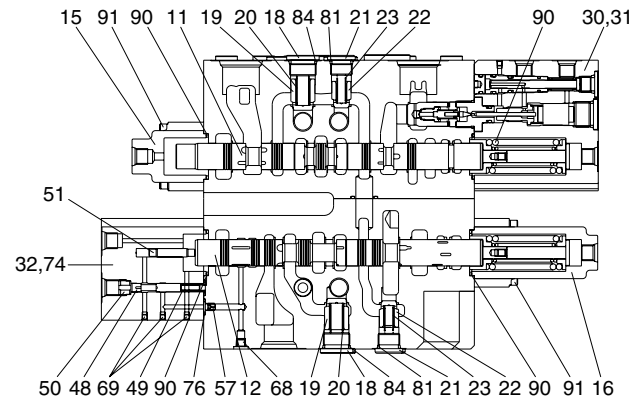

E - E (ARM & ARM REGENERATION /BREAKER)

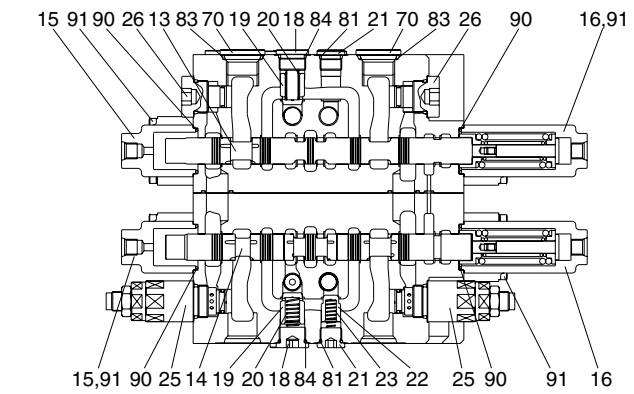

F - F (OPTION-B & BUCKET)

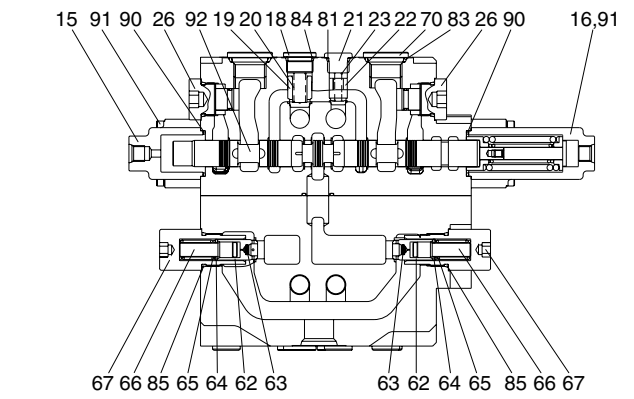

G - G (OPTION-C & NEGATIVE CONTROL)

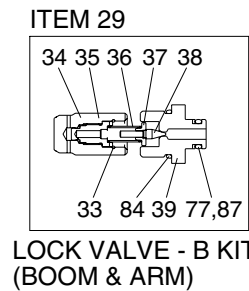
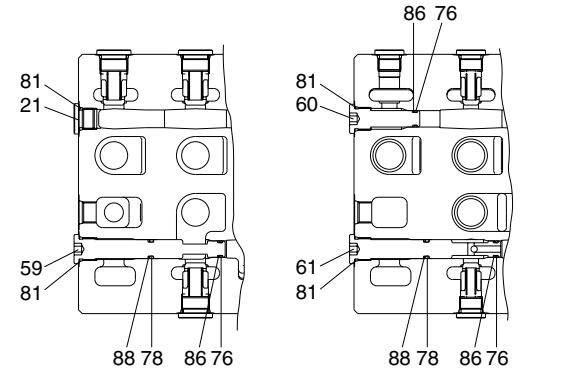

LOCK VALVE - B KIT (BOOM & ARM)

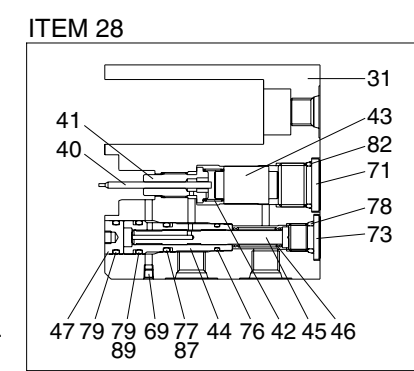

LOCK VALVE - A KIT (BOOM & ARM)

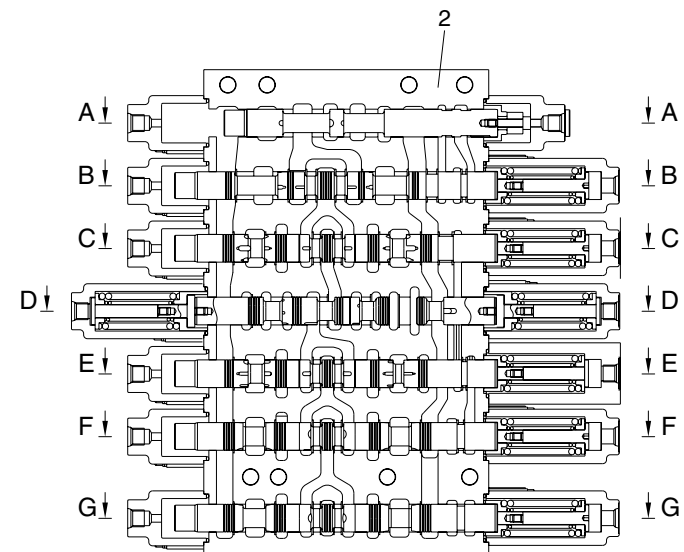

HOUSING P2 SIDE

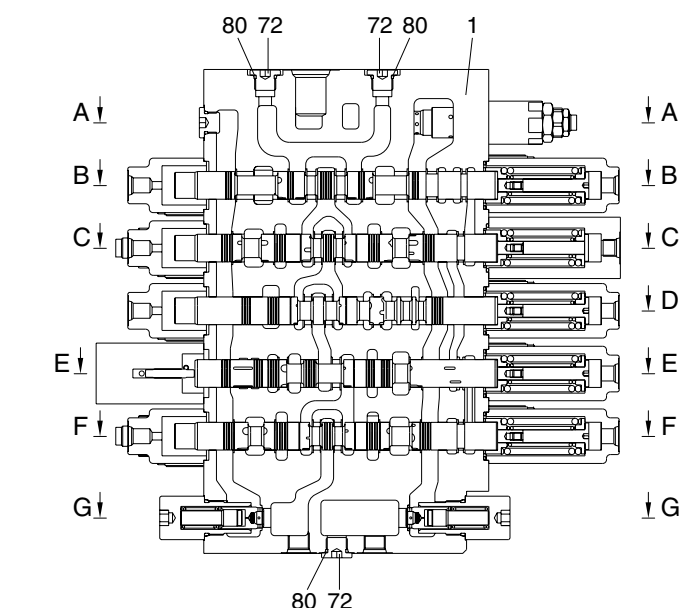

HOUSING P1 SIDE

- | | |
|-------------------------------------|----------------------------|
| 1 Housing-P1 | 47 Stopper-lock valve |
| 2 Housing-P2 | 48 Spool-regen selector |
| 3 Spool-straight travel | 49 Spring-regeneration |
| 4 Spool-travel | 50 Stopper-regeneration |
| 5 Spool-dozer | 51 Piston-cut off |
| 6 Spool-swing | 52 Poppet-signal |
| 7 Spool-boom 1 | 53 Spring-signal |
| 8 Spool-swing priority | 54 Plug |
| 9 Spool-boom 2 | 55 Orifice-signal |
| 10 Spool-arm 2 | 56 Coin type filter |
| 11 Spool-arm 1 | 57 Orifice-plug |
| 12 Spool-arm regeneration & breaker | 58 Plug |
| 13 Spool-option B | 59 Plug |
| 14 Spool-bucket | 60 Plug |
| 15 Cover-pilot A | 61 Plug-orifice |
| 16 Cover-pilot B1 | 62 Poppet-negative control |
| 17 Cover-Pilot B2 | 63 Coin type filter |
| 18 Plug | 64 Spring seat |
| 19 Poppet 1-check valve | 65 Spring-negative control |
| 20 Spring-check valve | 66 Piston-negative control |
| 21 Plug | 67 Socket-negative control |
| 22 Poppet 2-check valve | 68 Plug-taper |
| 23 Spring-check valve | 69 Plug-taper |
| 24 Main relief valve | 70 Plug |
| 25 Overload relief valve | 71 Plug |
| 26 Plug | 72 Plug |
| 27 Plug | 74 Socket head bolt |
| 28 Lock valve kit A | 75 O-ring |
| 29 Lock valve kit B | 76 O-ring |
| 30 Socket head bolt | 77 O-ring |
| 31 Block-Holding valve | 78 O-ring |
| 32 Block-Regeneration | 79 O-ring |
| 33 C-ring | 80 O-ring |
| 34 Poppet-lock valve | 81 O-ring |
| 35 Restrictor-lock valve | 82 O-ring |
| 36 Spring-lock valve pilot | 83 O-ring |
| 37 Guide-poppet | 84 O-ring |
| 38 Poppet-pilot | 85 O-ring |
| 39 Seat-poppet | 86 Back-up ring |
| 40 Piston 1 | 87 Back-up ring |
| 41 Guide-piston | 88 Back-up ring |
| 42 Spring1-lock valve | 89 Back-up ring |
| 43 Piston 2 | 90 O-ring |
| 44 Sleeve | 91 Socket head bolt |
| 45 Spool-lock valve | 92 Spool-option C |
| 46 Spring 2-lock valve | |

2. HYDRAULIC CIRCUIT

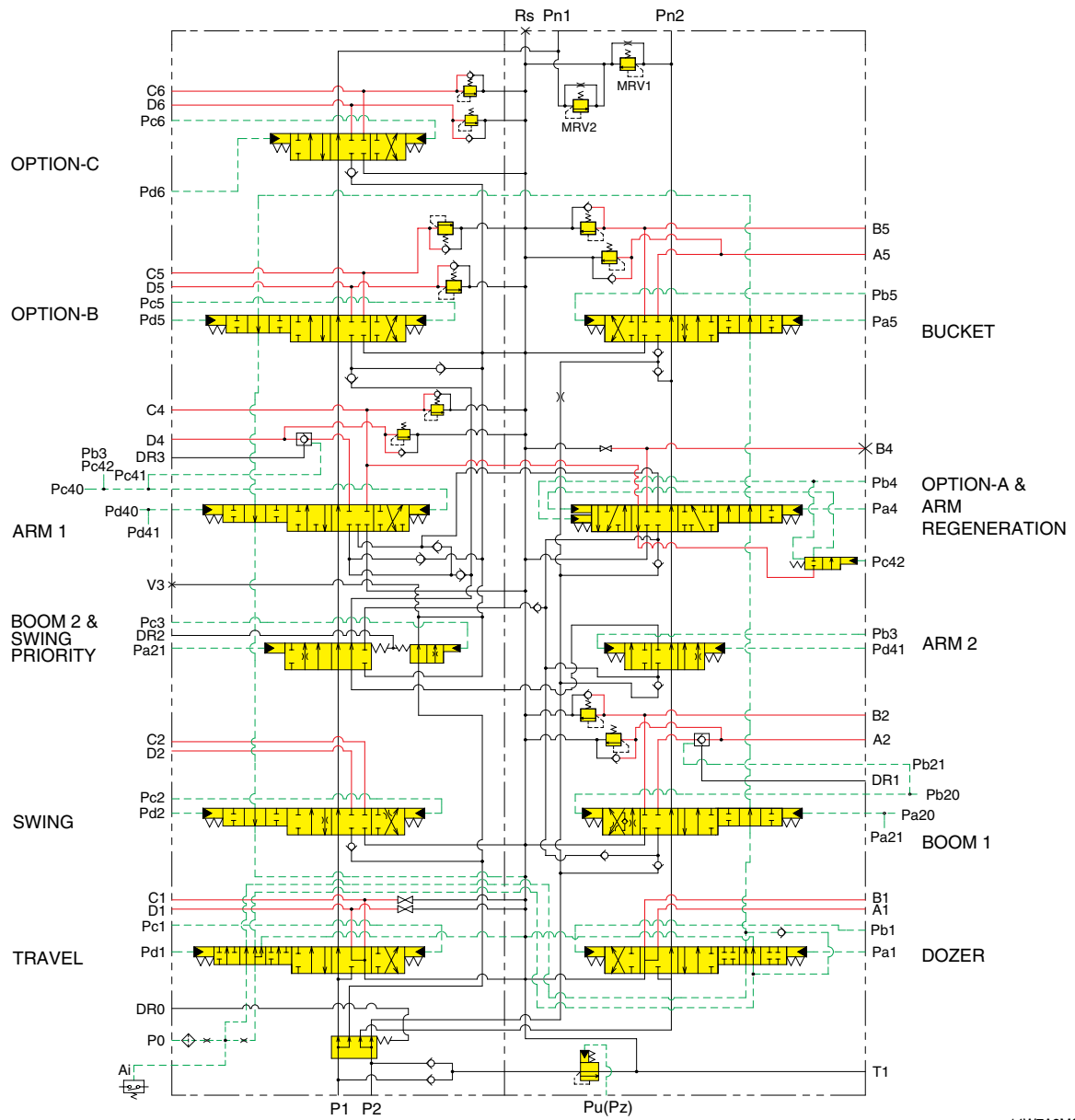

14W7A2MC05

3. FUNCTION

1) CONTROL IN NEUTRAL FUNCTION

(1) P1 SIDE

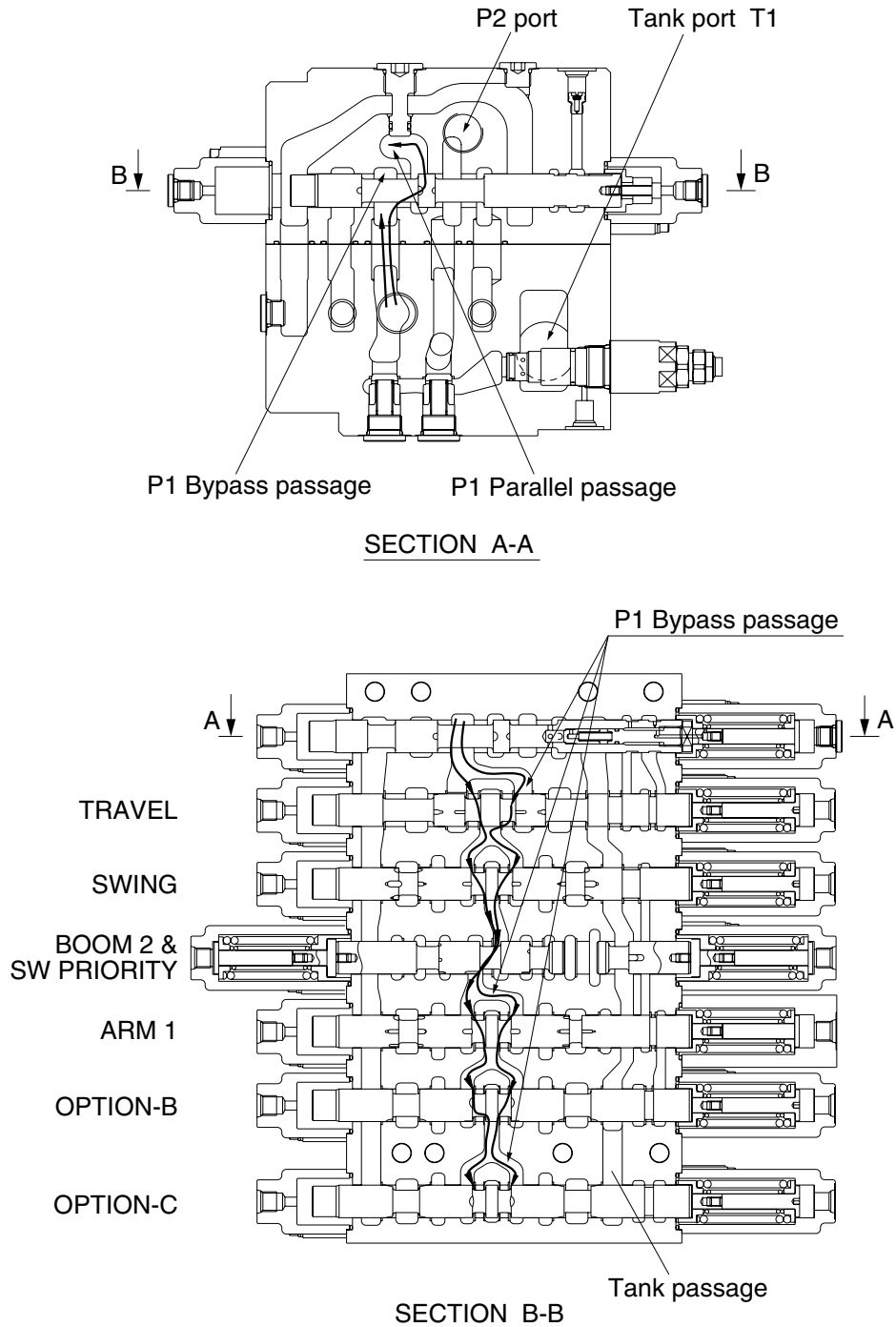

The hydraulic fluid from pump A1 flows into the main control valve through the inlet port "P1", into the P1 bypass passage and P1 parallel passage.

The hydraulic fluid from the pump A1 is directed to the tank through the bypass passage of spools : travel, swing, boom 2 & swing priority, arm 1, option "B" and option "C", and the negative relief valve with the tank passage.

14W7A2MC12

(2) P2 SIDE

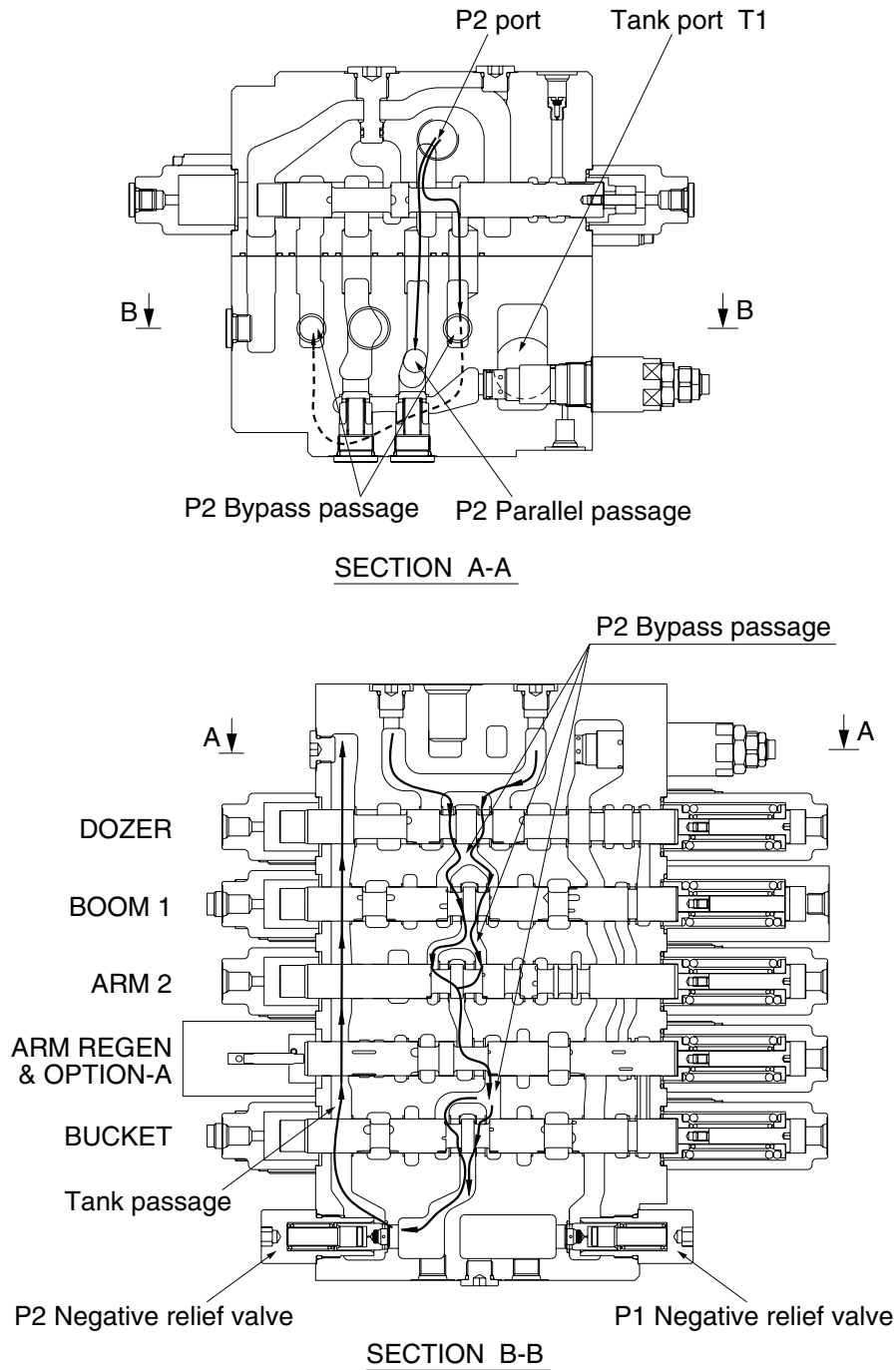

14W7A2MC11

The hydraulic fluid from pump A2 flows into the main control valve through the inlet port "P2", into the P2 bypass passage and P2 parallel passage.

The hydraulic fluid from the pump A2 is directed to the tank through the bypass passage of spools : dozer, boom 1, arm 2, arm regeneration & option A and bucket, the negative relief valve, tank passage, and the tank port "T1"

2) EACH SPOOL OPERATION

(1) TRAVEL OPERATION

① Travel forward operation

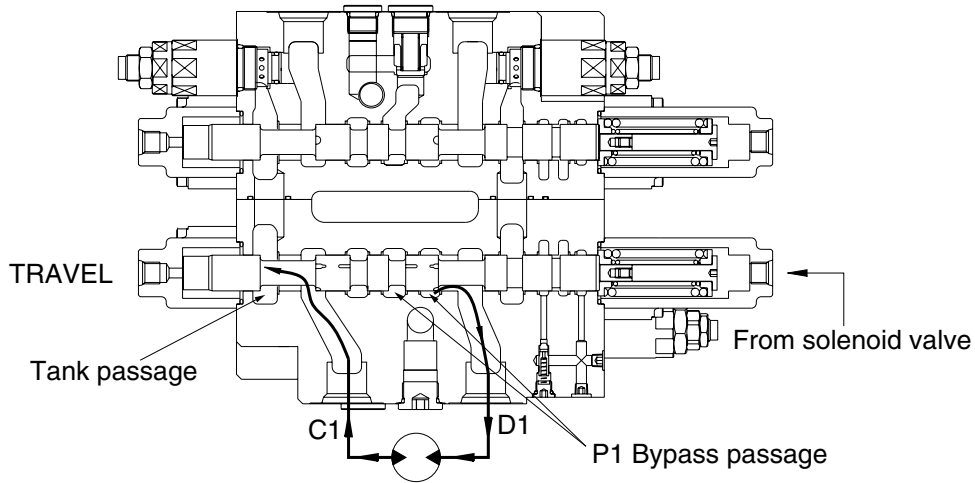

14W7A2MC17

② Travel backward operation

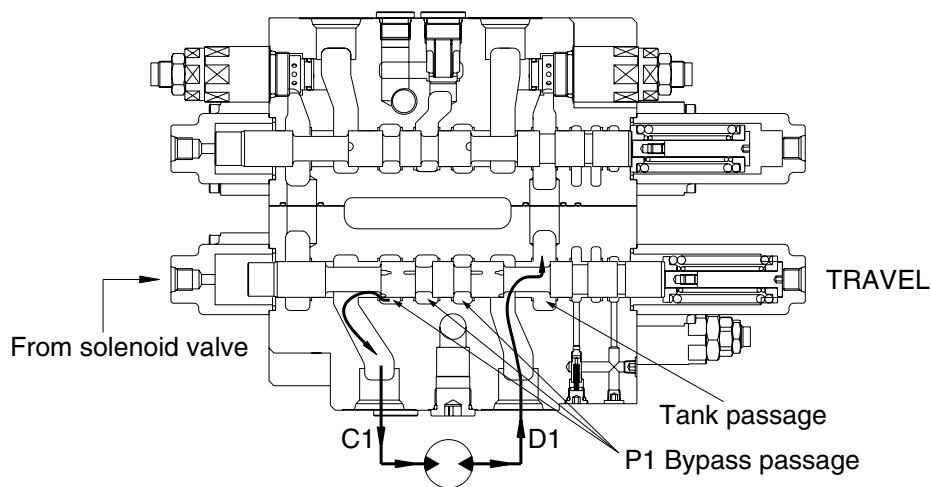

14W7A2MC18

During the travel operation, the hydraulic fluid of the pump A1 is supplied to the travel motor. The pilot pressure from the solenoid valve is supplied to the spring side of pilot port (pd1). And it shifts travel spool in the left direction against springs. Hydraulic fluid from the pump A1 flow into the travel spool through the bypass passage. Then they are directed to the travel motor through port D1. As a result, the travel motor turn and hydraulic fluid returns to the tank passage through the travel spool. In case of the opposite operation, the operation is similar.

(2) DOZER OPERATION

① Dozer down operation

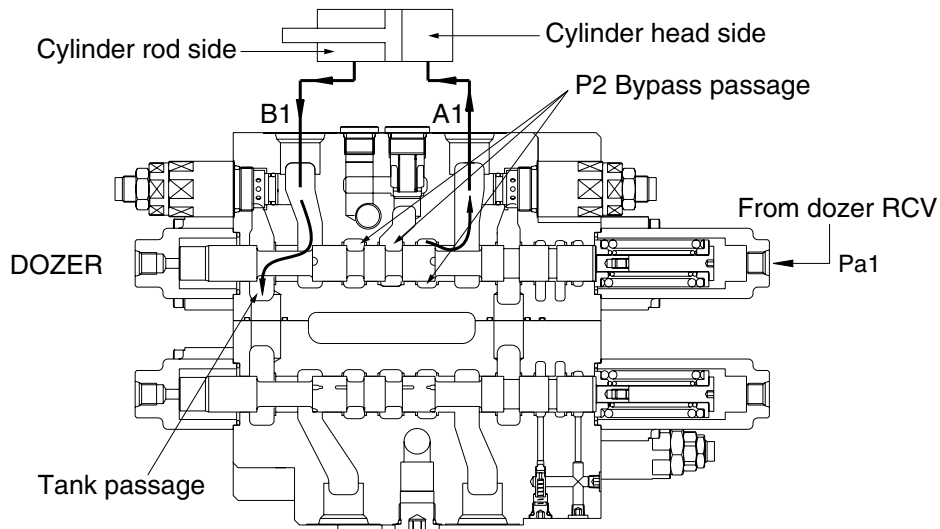

14W7A2MC30

② Dozer up operation

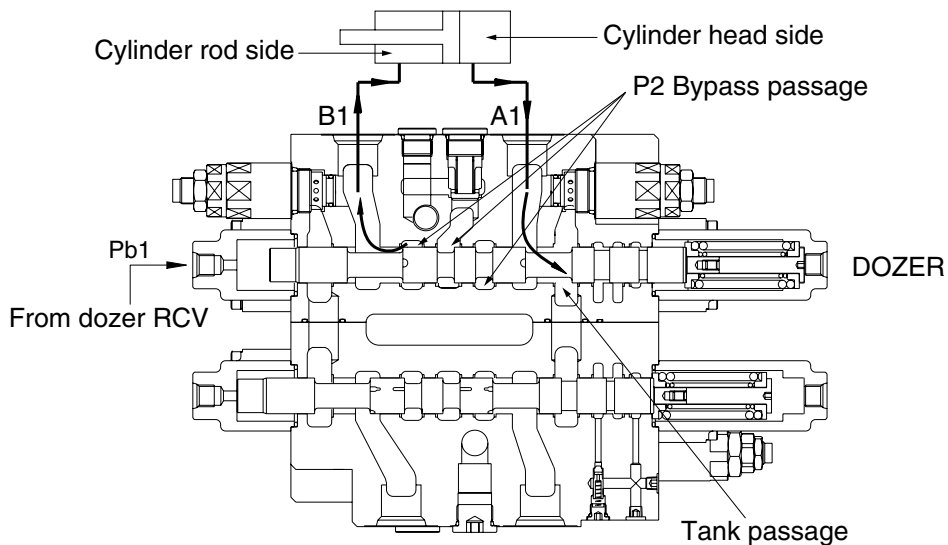

14W7A2MC31

During dozer down operation, the pilot pressure from the dozer control valve is supplied into the port Pa1 and shift the dozer spool in the left direction.

The hydraulic fluid from the pump A2 enters the bypass passage and is directed to the head side of the dozer cylinder through port A1.

The return flow from the rod side of the dozer cylinder returns to the dozer spool through B1 port. Thereafter it is directed to the hydraulic tank through tank passage.

In case of the dozer up operation, operation is similar.

(3) BOOM OPERATION

① Boom up operation

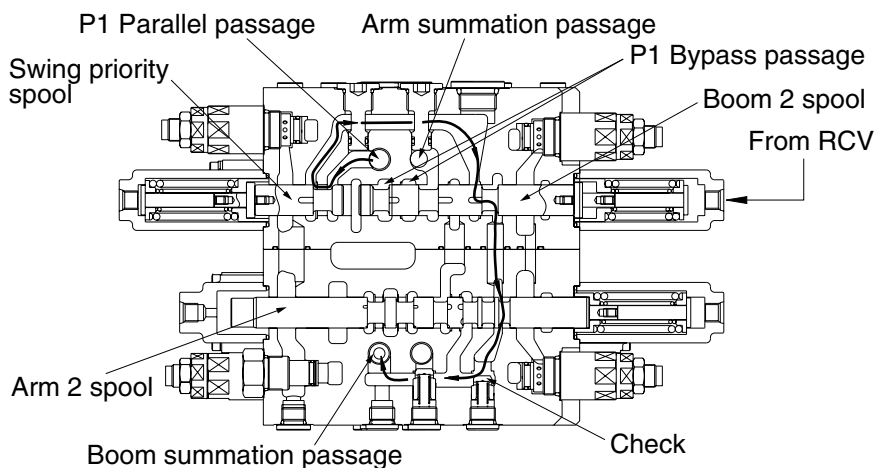
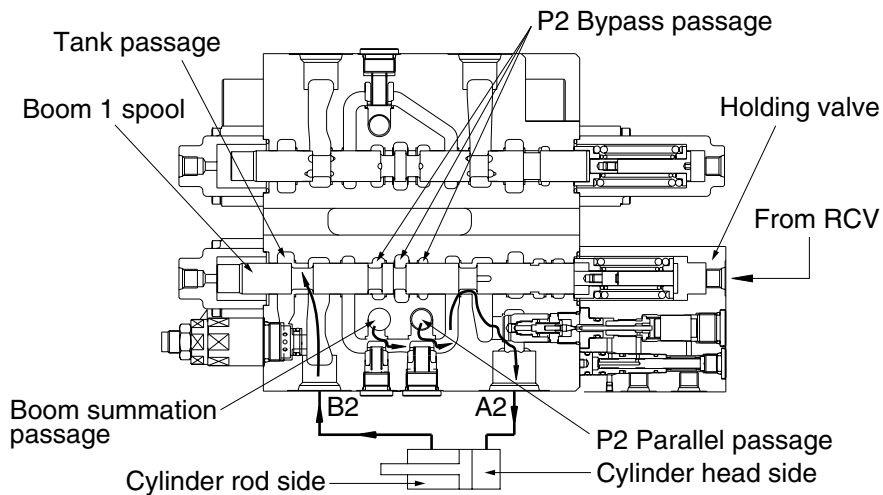

1607A2MC24A

During boom up operation, the pilot pressure from RCV is supplied into the port Pa20 and shift the boom 1 spool in the left direction. The hydraulic oil fluid from pump A2 is entered P2 parallel passage and then passes through the load check valve and boom holding valve then flows into the port A2.

Following this it flows into the head side of the boom cylinder.

(In this case, the boom holding valve is free flow condition)

At the same time the pilot pressure through the port Pa21 shifts the boom 2 spool. The hydraulic oil fluid from pump A1 entered boom summation passage via the P1 parallel passage, the swing priority spool, the boom 2 spool, arm 2 spool and the check. The flows combine in passage and are directed to port A2 and head side of boom cylinder.

The flow from rod side of the boom cylinder return to the boom 1 spool through the port B2. There after it is directed to the hydraulic oil tank through the tank passage.

② Boom down operation

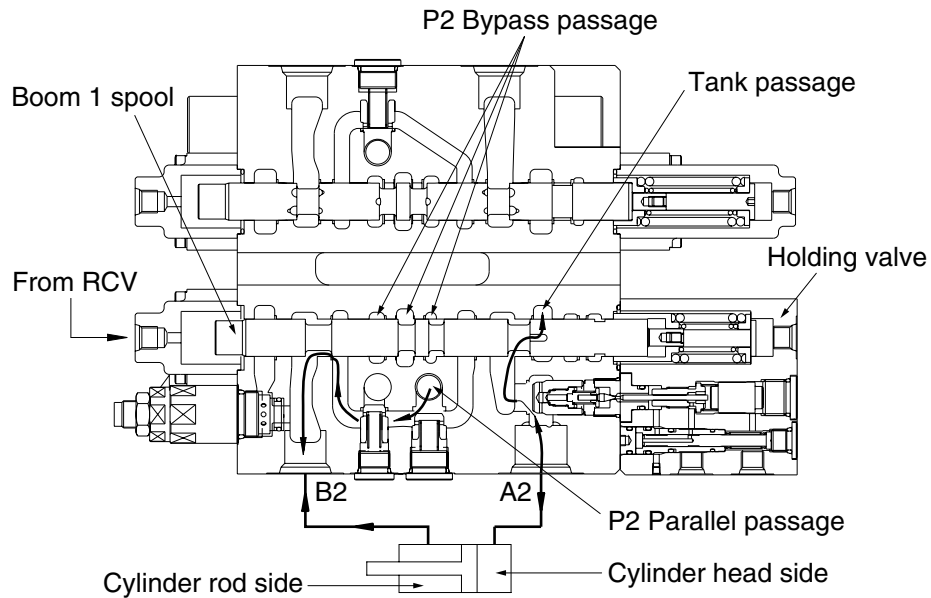

1607A2MC26

During the boom lowering operation, the pilot pressure from RCV is supplied to the port Pb20 and shift the boom1 spool in the right direction.

The hydraulic fluid from the pump A2 enters the parallel passage and is directed to the port B2 through the load check valve. Following this, it flows into the rod side of the boom cylinder.

The return flow from the head side of the boom cylinder returns to the boom 1 spool through the port A2 and boom holding valve. Thereafter it is directed to the hydraulic oil tank through tank passage.

For details of the boom holding valve, see page 2-37.

(4) BUCKET OPERATION

① Bucket roll in operation

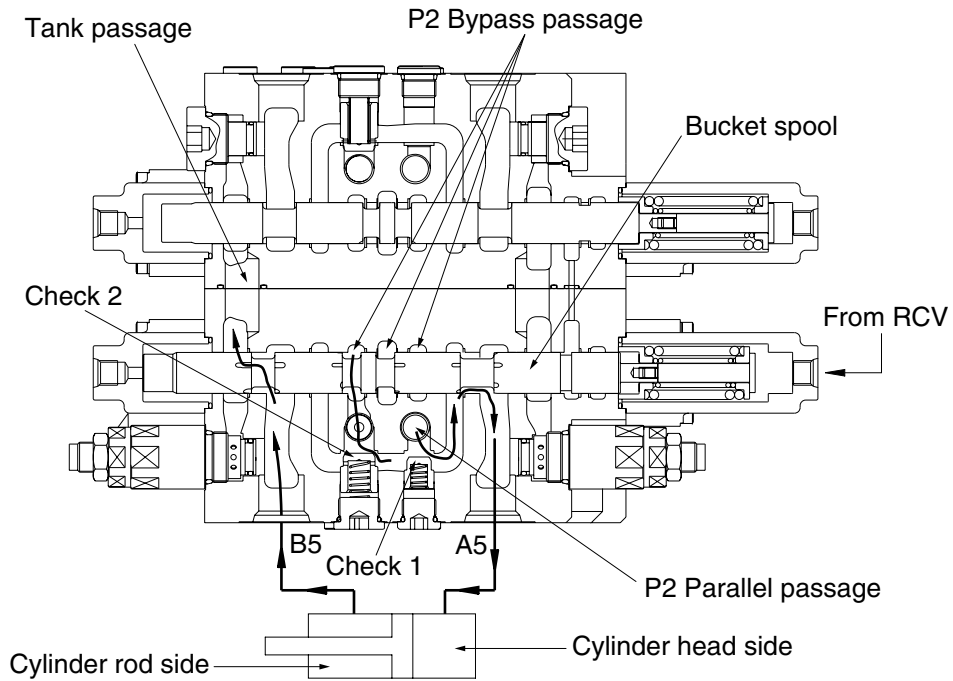

1607A2MC34A

② Bucket roll out operation

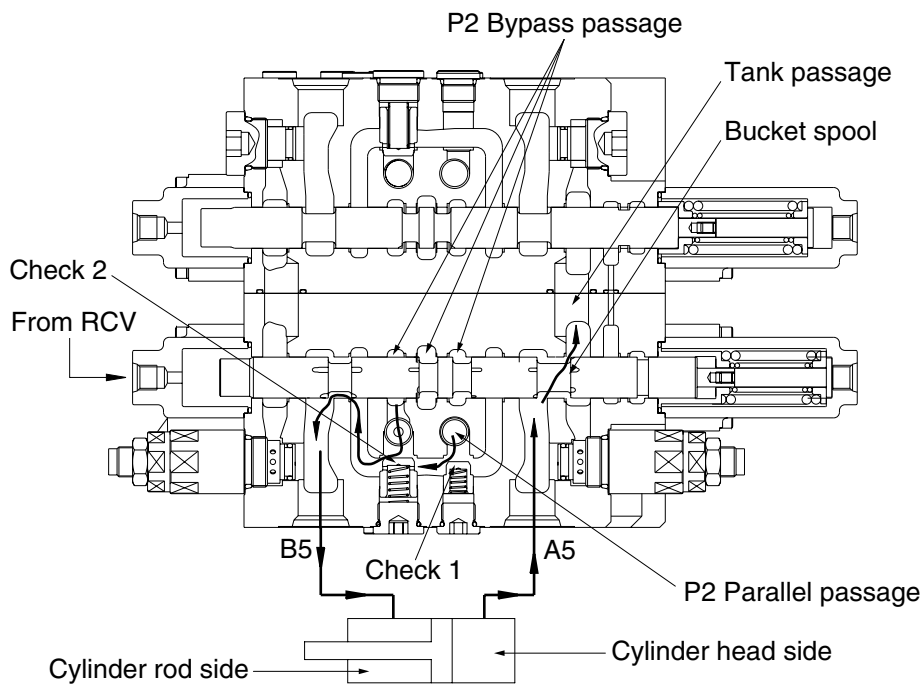

1607A2MC35

① **Bucket roll in operation**

During the bucket roll in operation, the pilot pressure from RCV is supplied to port Pa5 and shift the bucket spool in the left direction.

The hydraulic fluid from pump A2 entered P2 parallel passage and is directed to the port A5 through the check 1.

At the same time, the hydraulic fluid from P2 bypass passage is directed to the port A5 through the check 2.

Following this it flows into the head side of the bucket cylinder.

The return flow from the rod side of the bucket cylinder returns to the bucket spool through the port B5. Thereafter it is directed to the hydraulic oil tank through the tank passage.

② **Bucket roll out operation**

In case of the bucket roll out operation, the operation is similar.

③ **Bucket operation with arm or boom operation**

When combined operation, mostly same as above but the fluid from bypass passage is empty.

So only the fluid from parallel passage is supplied to the bucket cylinder. Also, parallel passage is installed the orifice for supplying the fluid from pump to the boom or the arm operation prior to the bucket operation.

(5) SWING OPERATION

① Swing left operation

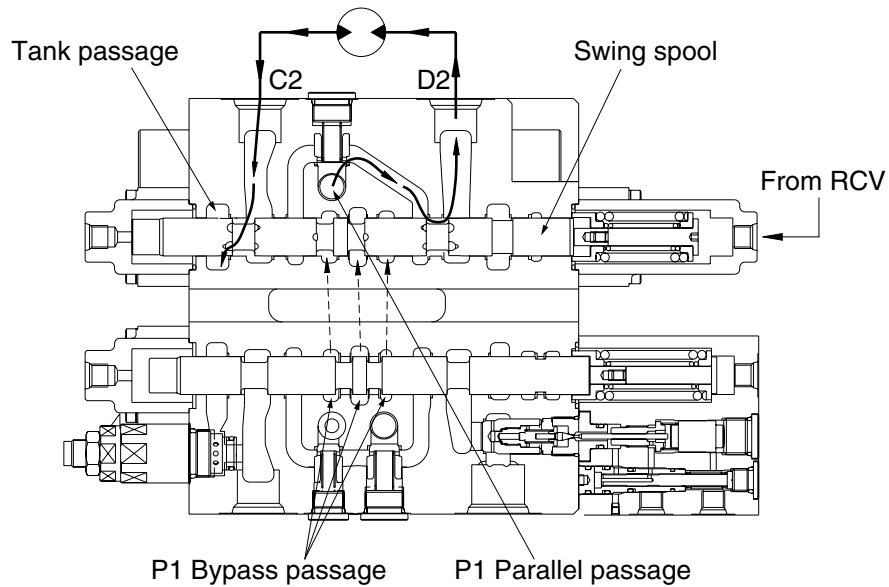

1607A2MC32

② Swing right operation

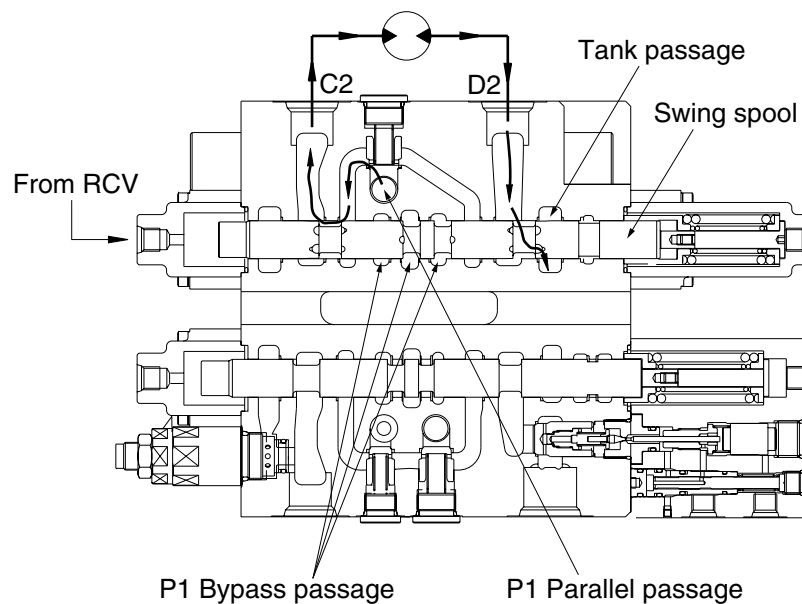

1607A2MC33

The pilot pressure from the RCV is supplied to the Pd2 and shift the swing spool in left direction. The hydraulic fluid from pump A1 flows into swing spool through the parallel passage. Then it is directed to swing motor through the port D2. As the result, swing motor turns and flow from the swing motor returns to the hydraulic oil tank through the port C2, swing spool and the tank passage . In case of swing right operation, the operation is similar.

(6) ARM OPERATION

① Arm roll in operation

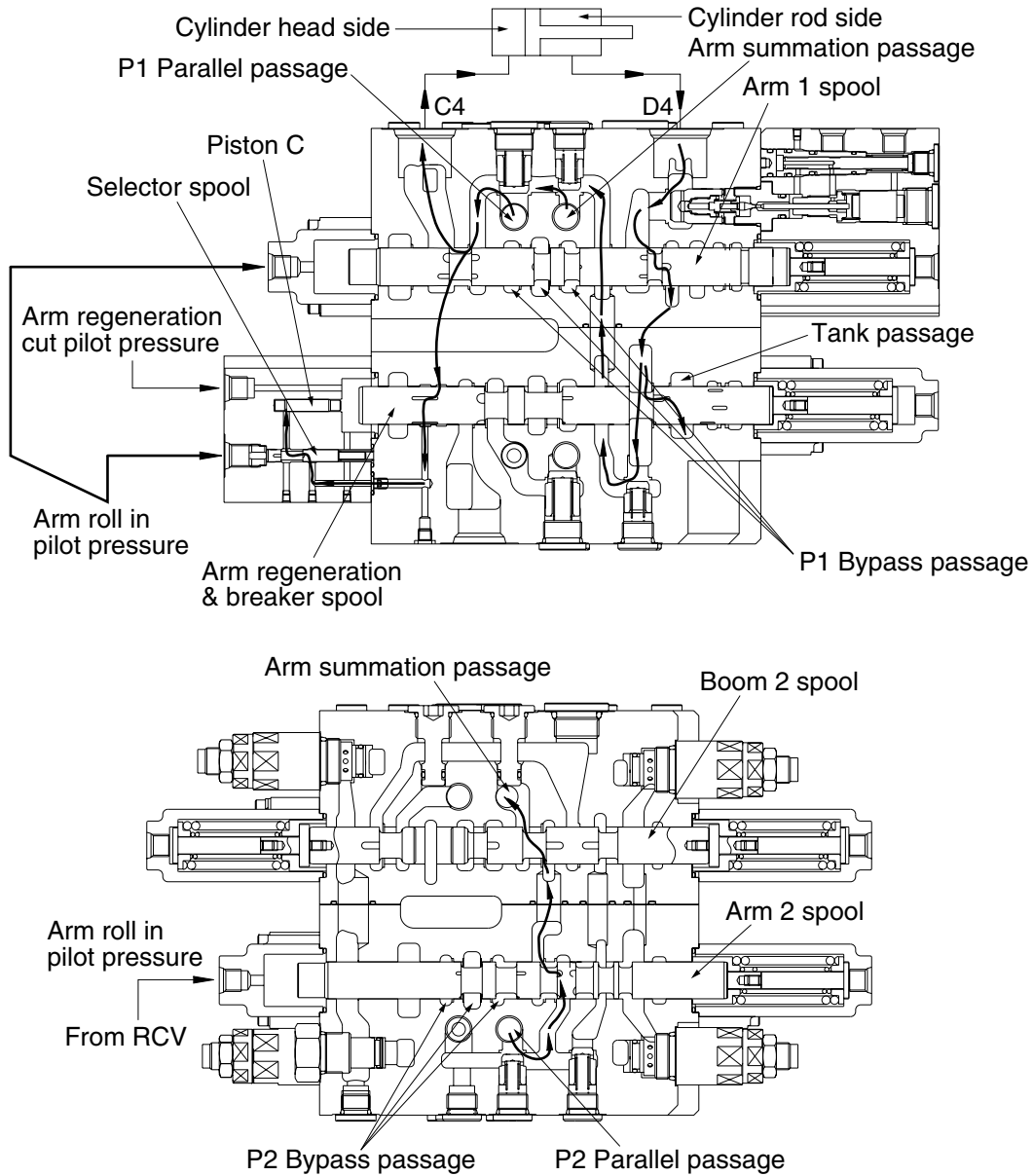

1607A2MC21

• Arm roll in operation :

During arm roll in operation the pilot pressure from the RCV is supplied to the port Pc40 and Pb3 and shifts arm 1 spool and arm 2 spool in the right direction.

The hydraulic oil from the pump A1 flows into the arm cylinder head side through P1 parallel passage, the load check valve and the port C4.

At same time, the hydraulic fluid from the pump A2 flows into the arm summation passage through parallel passage, the check valve, the arm 2 spool and the boom 2 spool. Then it entered the arm cylinder head side with hydraulic fluid from arm1 spool.

• **Arm regeneration :**

The return flow from the arm cylinder rod side is pressurized by self weight of arm and so, returns to port D4. The pressurized oil returning to port D4 enters the arm regeneration & breaker spool through the arm holding valve and the arm1 spool. It is supplied the arm cylinder head through internal passage. This is called the arm regeneration function.

The amount of regeneration fluid are changed by movement of the arm regeneration & breaker spool.

A few fluid after P1 parallel passage is push piston "C" through the notch of arm regeneration spool and selector spool. At this time, the selector spool is opened by pilot pressure from RCV.

Then, the arm regeneration spool shift to right side and flow to tank pass increases and regeneration flow decreases. Therefore, pressure of arm cylinder head increases, then, arm regeneration flow decreases.

Furthermore, the arm regeneration cut pressure is supplied to port and arm regeneration spool is move into the right direction fully. The flow from the arm cylinder rod is returned to the hydraulic oil tank and regeneration function is not activated.

② Arm roll out operation

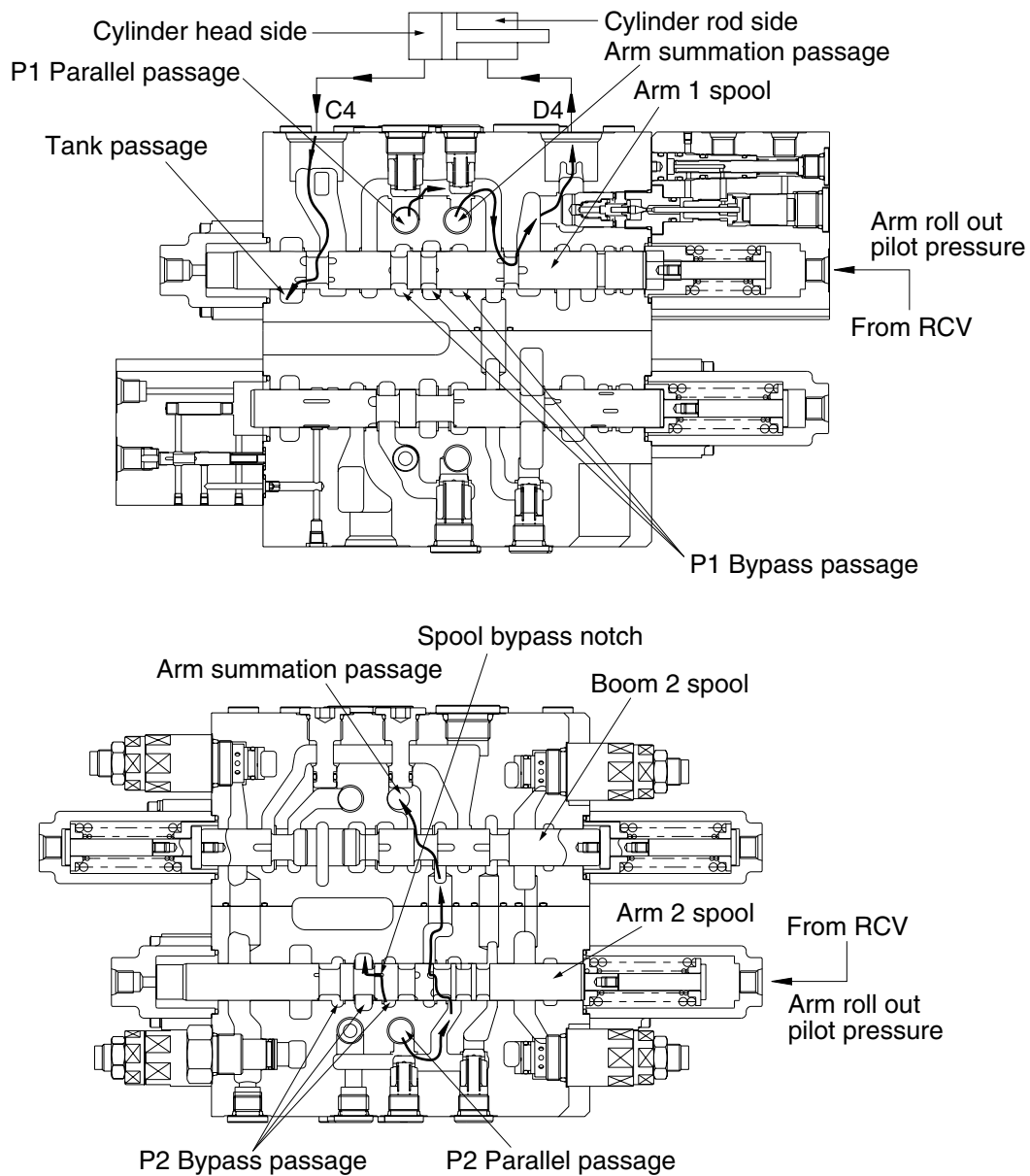

1607A2MC23

During arm roll out operation the pilot pressure from RCV is supplied to the port Pd40 and the Pd41 and shifts arm 1 spool and arm 2 spool in the right direction.

The hydraulic fluid from pump A1 flows into arm 1 spool through the parallel passage. Then it enters into the arm cylinder rod side through the load check valve, bridge passage, arm holding valve and the port D4.

Some of the hydraulic fluid from pump A1 bypassed through bypass notch.

The rest of hydraulic fluid from pump A2 flows into the arm summation passage through P2 parallel passage the check valve arm 2 spool and boom 2 spool.

Then it enters into the arm cylinder rod side with the fluid from the arm 1 spool.

The return flow from the arm cylinder head side returns to the hydraulic tank through the port C4 the arm 1 spool and tank passage.

(7) SWING PRIORITY FUNCTION

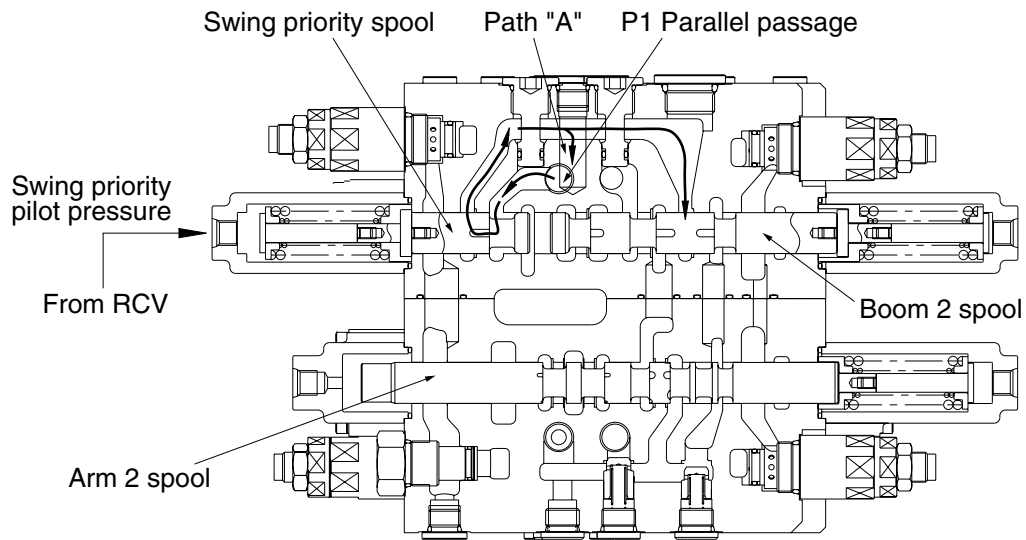

1607A2MC27

During swing priority operation, the pilot pressure is supplied to the port Pc3 and shift swing priority spool in the right direction.

The hydraulic fluid from P1 parallel passage flows into the parallel passage of arm 1 side through swing priority spool and the passage "A" and also flows into the boom 2 spool.

Due to shifting of the swing priority spool, the fluid from pump A1 flows to swing side more then next spools to make the swing operation most preferential.

(8) HOLDING VALVE OPERATION

① Holding operation

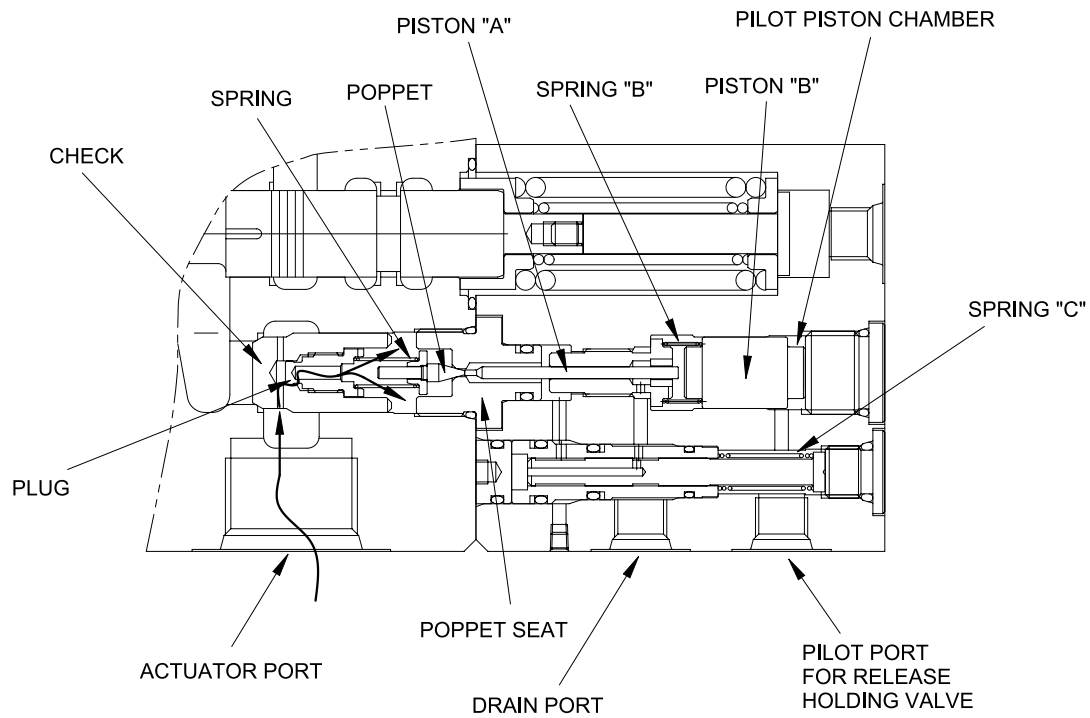

14072SF30

At neutral condition, the pilot piston chamber is connected to drain port through the pilot port.

And the piston "B" is supported with spring "B" and the pressured fluid from actuator entered to inside of the holding valve through the periphery hole of check, crevice of the check and the plug and the periphery hole of plug.

Then, this pressured oil pushed the poppet to the poppet seat and the check to the seat of body.

So the hydraulic fluid from actuator is not escaped and the actuator is not moved.

② Release holding operation

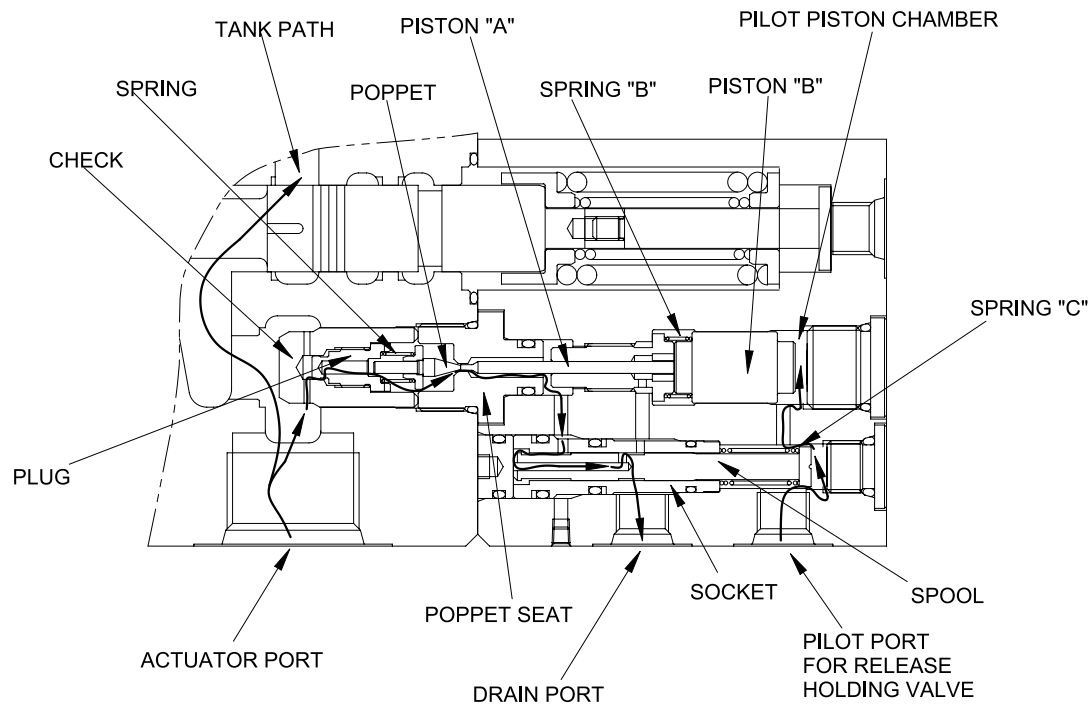

14072SF31

The pilot pressure is supplied to the pilot port for release holding valve and shifts the piston "B" in the left direction against the spring "B", and shifts the poppet in the left direction through piston "B" and piston "A" against spring "B" and shifts the spool in the left side.

At same time, the return fluid from actuator returns to the drain port through the periphery hole of check, crevice of the check and the plug, the periphery hole of the plug, in side of holding valve, crevice of the poppet and the poppet seat, the periphery hole of the poppet seat, crevice of the socket and spool and inside of spool.

When the poppet is opened, pressure of inside of holding valve is decreased and the return fluid from actuator returns to the tank passage through the notch of spool.

(9) NEGATIVE RELIEF VALVE CONTROL

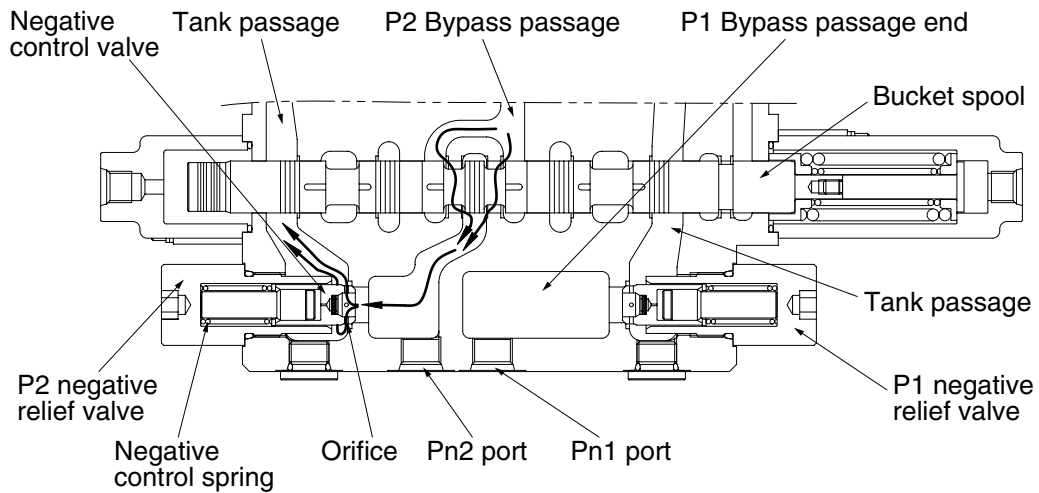

1607A2MC28

When no function is being actuated on P2 side, the hydraulic fluid from the pump A2, flows into the tank passage through the bypass passage and orifice. The restriction caused by this orifice thereby pressurizes. This pressure is transferred as the negative control signal pressure Pn2 to the pump P2 regulator.

It controls the pump regulator so as to minimize the discharge of the pump A2.

The bypass passage is shut off when the shifting of one or more spools and the flow through bypass passage became zero. The pressure of negative control signal become zero and the discharge of the pump P2 become maximum.

The negative control pressure reaches to the set level, the hydraulic fluid in the passage pushes open negative control valve and escapes into the return passage.

For the pump A1 the same negative control principle.

(10) OPERATION OF MAIN RELIEF VALVE

The main relief valve is fitted to the straight travel valve block and functions as follows :

- ① The pressurized oil passes through the orifice (A) of the plunger is filled up in chamber A of the inside space, and seats the plunger against the housing securely.

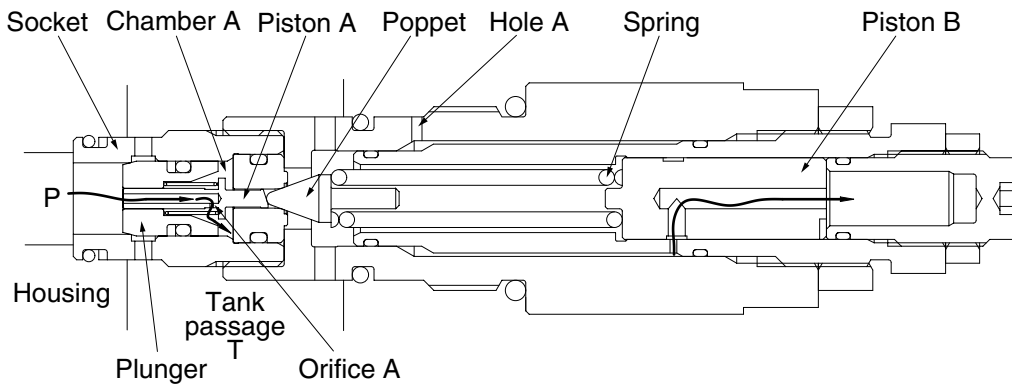

1607A2MC36

- ② When the pressure at (P) becomes equal to the set pressure of the spring the hydraulic oil passes through the piston (A) pushes open the poppet and flows to tank passage (T) through the hole (E).

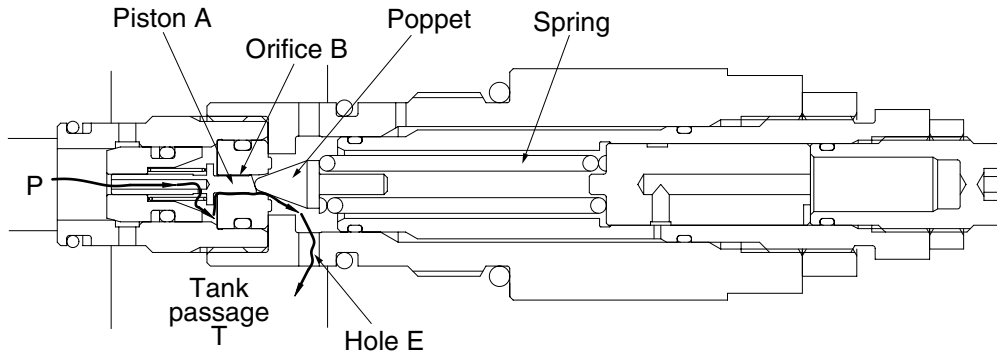

1607A2MC37

- ③ Opening the poppet causes the pressure in chamber A to fall and the plunger to open. As the result the pressurized oil at port P runs into tank passage (T)

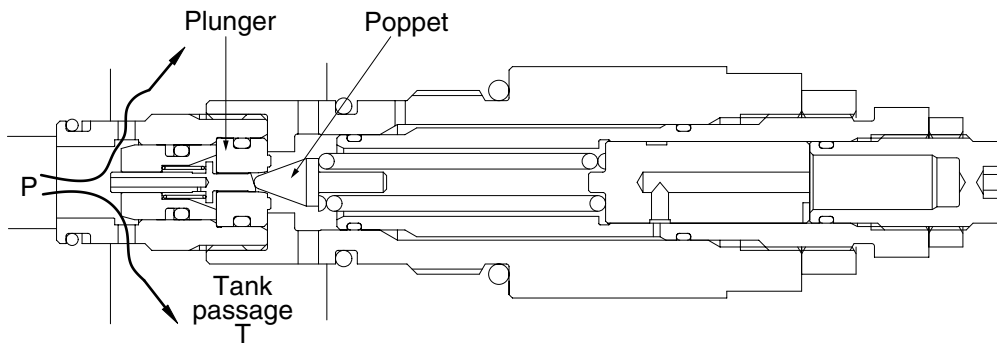

1607A2MC38

- ④ High pressure setting pilot signal(Pu) : ON
 When the power boost switch is ON, the pilot pressure enters through hole A.
 It pushes the piston(B) in the left direction to increase the force of the spring and change the relief set pressure to the high pressure.

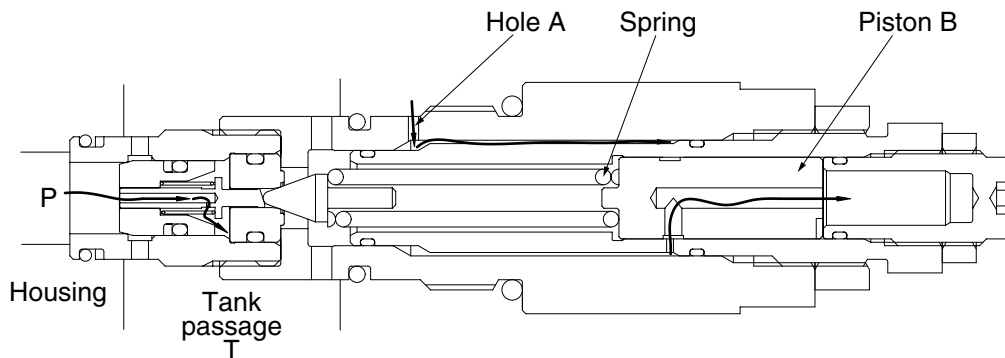

1607A2MC36A

(11) OPERATION OF PORT RELIEF VALVE

① Function as relief valve

- ① The pressurized oil passes through the piston A and orifice is filled up in chamber A of the inside space and seat the plunger against the socket and the socket against the the housing securely.

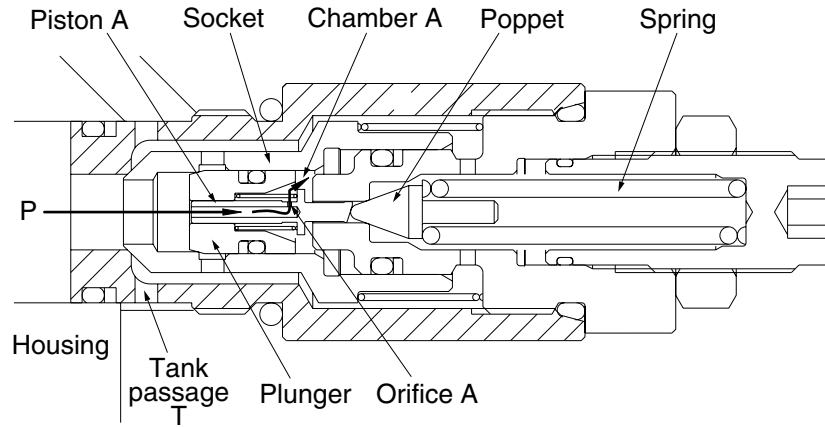

1607A2MC39

- ② When the pressure at port P becomes equal to the set pressure of the spring, the pressurized oil pushes open the poppet flows to tank passage (T) through hole E.

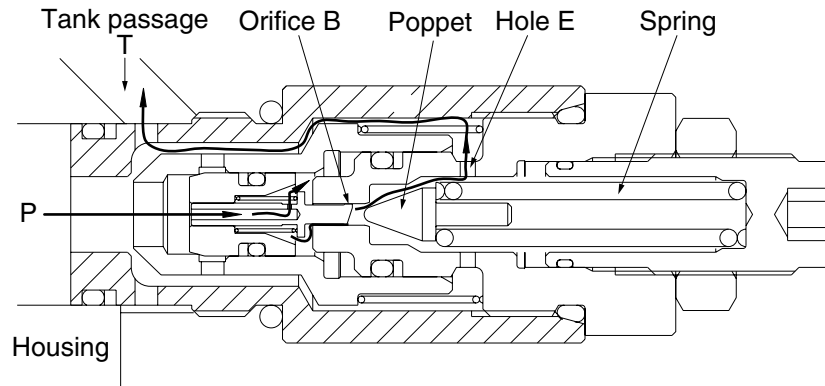

1607A2MC40

- © Opening of the poppet causes the pressure in chamber A to fall and the plunger to open. As the result the pressurized oil at port P runs into tank passage (T).

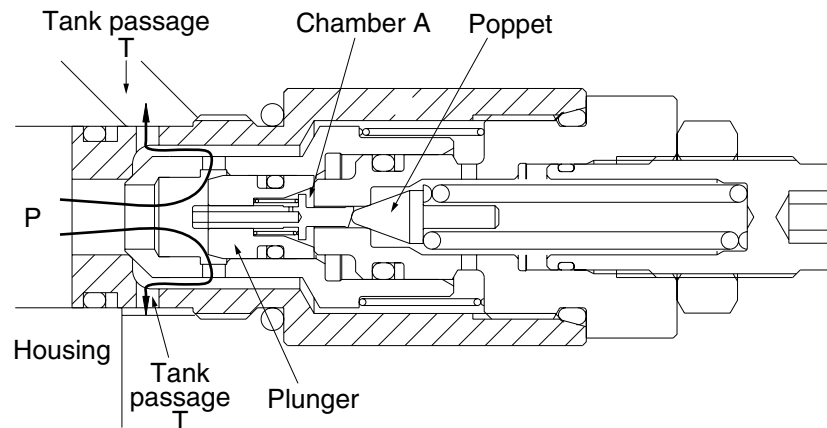

1607A2MC41

② **Make-up function**

When negative pressure exists at port P, the oil is supplied through tank passage (T). When the pressure at tank passage (T) becomes higher than that at port P, the socket moves in the right direction. Then, sufficient oil passes around the socket from tank passage (T) to port P and fills up the space.

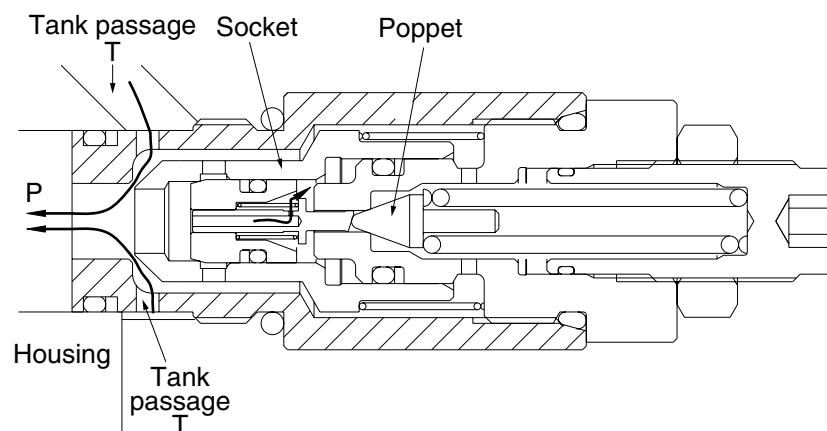

1607A2MC42