

GROUP 2 SPECIFICATIONS

1. MAJOR COMPONENT

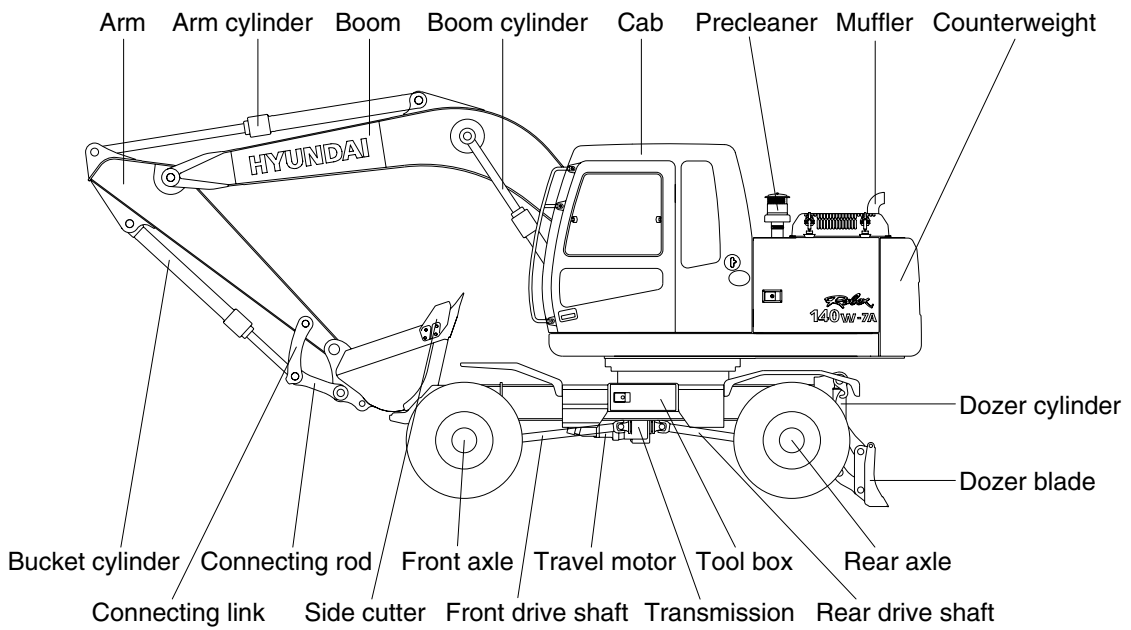
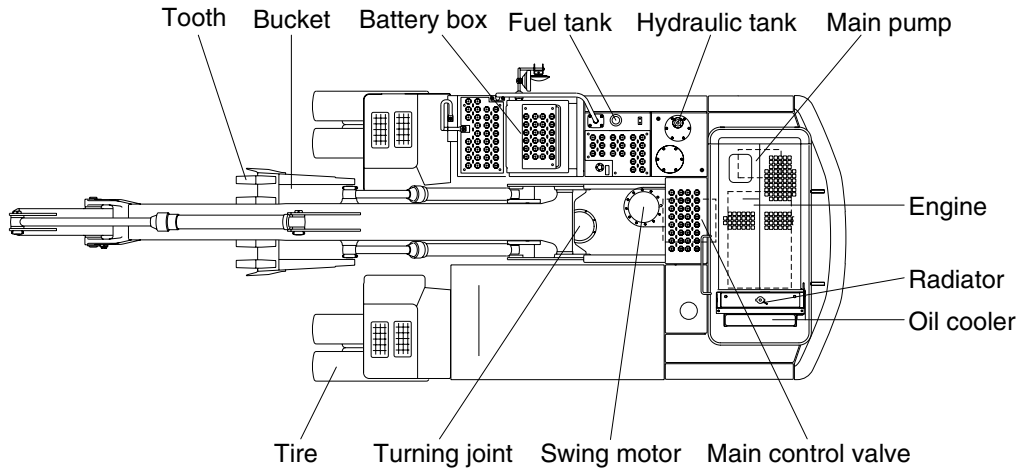

14W7A2SP01

2. SPECIFICATIONS

1) 4.6m(15' 1") ONE PIECE BOOM, 2.1m(6'11") ARM AND REAR DOZER BLADE

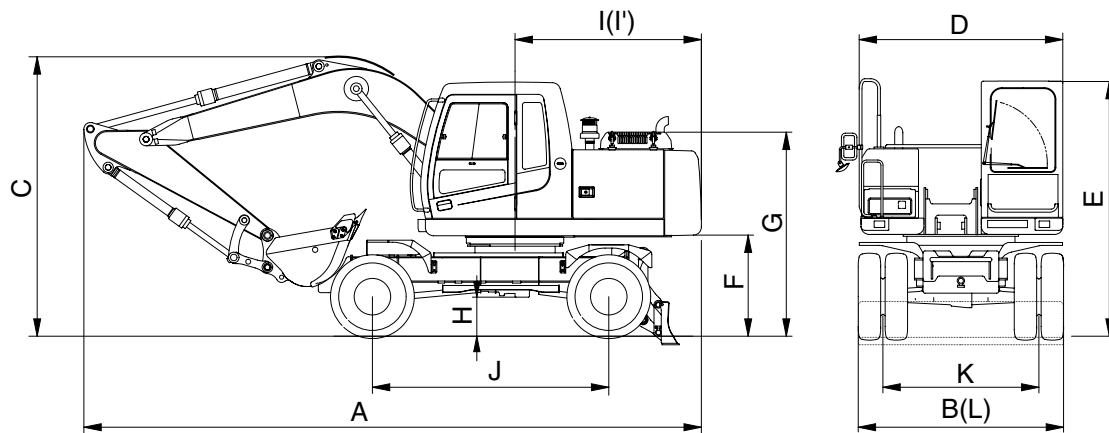

14W7A2SP02

Description		Unit	Specification
Operating weight		kg (lb)	13500 (29760)
Bucket capacity (SAE heaped), standard		m ³ (yd ³)	0.58 (0.76)
Overall length	A	mm (ft-in)	7800 (25' 7")
Overall width	B		2500 (8' 2")
Overall height	C		3500 (11' 6")
Upperstructure width	D		2475 (8' 1")
Cab height	E		3140 (10' 4")
Ground clearance of counterweight	F		1240 (4' 1")
Engine cover height	G		2340 (7' 8")
Minimum ground clearance	H		435 (1' 5")
Rear-end distance	I		2290 (7' 6")
Rear-end swing radius	I'		2310 (7' 7")
Wheel base	J		2600 (8' 6")
Tread	K		1929 (6' 4")
Dozer blade width	L		2490 (8' 2")
Travel speed	Low		km/hr (mph)
	High	30.0 (18.7)	
Swing speed		rpm	12.4
Gradeability		Degree (%)	33 (65)

3. WORKING RANGE

1) 4.6m(15' 1") MONO BOOM

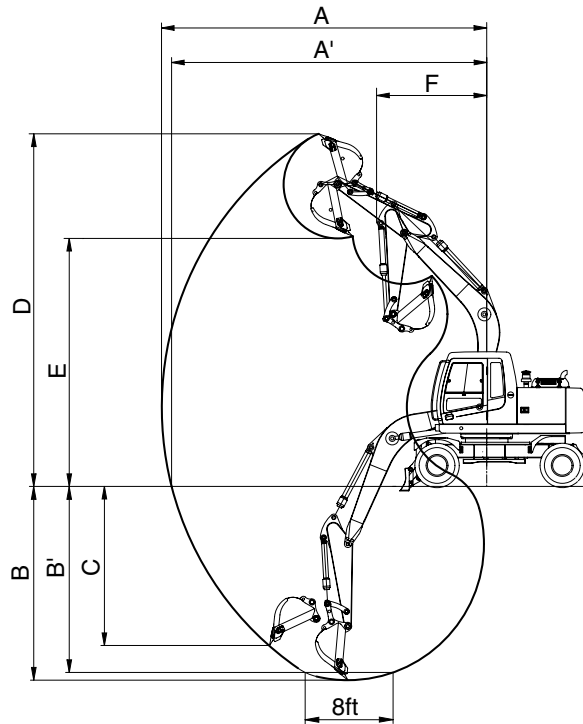

14W7A2SP03

Description		1.9m (6' 3") Arm	*2.1m (6' 11") Arm	2.5m (8' 2") Arm	3.0m (9' 10") Arm
Max digging reach	A	7750mm (25' 5")	7920mm (26' 0")	8330mm (27' 4")	8790mm (28'10")
Max digging reach on ground	A'	7530mm (24' 8")	7700mm (25' 3")	8120mm (26' 8")	8590mm (28' 2")
Max digging depth	B	4620mm (15' 2")	4820mm (15'10")	5220mm (17' 2")	5720mm (18' 9")
Max digging depth (8ft level)	B'	4360mm (14' 4")	4570mm (15' 0")	5020mm (16' 6")	5540mm (18' 2")
Max vertical wall digging depth	C	4100mm (13' 5")	4230mm (13'11")	4770mm (15' 8")	5300mm (17' 5")
Max digging height	D	8420mm (27' 7")	8490mm (27'10")	8820mm (28'11")	9090mm (29'10")
Max dumping height	E	5980mm (19' 7")	6060mm (19'11")	6380mm (20'11")	6640mm (21' 9")
Min swing radius	F	2620mm (8' 7")	2680mm (8'10")	2630mm (8' 8")	2670mm (8' 9")
Bucket digging force	SAE	83.4 [91]kN	83.4 [91]kN	83.4 [91]kN	83.4 [91]kN
		8500 [9270]kgf	8500 [9270]kgf	8500 [9270]kgf	8500 [9270]kgf
		18740 [20440]lbf	18740 [20440]lbf	18740 [20440]lbf	18740 [20440]lbf
	ISO	96.1 [104.8]kN	96.1 [104.8]kN	96.1 [104.8]kN	96.1 [104.8]kN
		9800 [10690]kgf	9800 [10690]kgf	9800 [10690]kgf	9800 [10690]kgf
		21610 [23570]lbf	21610 [23570]lbf	21610 [23570]lbf	21610 [23570]lbf
Arm digging force	SAE	74.5 [81.3]kN	71.6 [78.1]kN	61.8 [67.4]kN	53.9 [59.0]kN
		7600 [8290]kgf	7300 [7960]kgf	6300 [6870]kgf	5500 [6020]kgf
		16760 [18280]lbf	16090 [17550]lbf	13890 [15150]lbf	12130 [13270]lbf
	ISO	78.5 [85.6]kN	75.5 [82.4]kN	64.7 [70.6]kN	56.9 [62.1]kN
		8000 [8730]kgf	7700 [8400]kgf	6600 [7200]kgf	5800 [6330]kgf
		17640 [19240]lbf	16980 [18520]lbf	14550 [15870]lbf	12790 [13950]lbf

* : Standard

[] : Power boost

2) 4.9m (16' 1") HYDRAULIC ADJUSTABLE BOOM

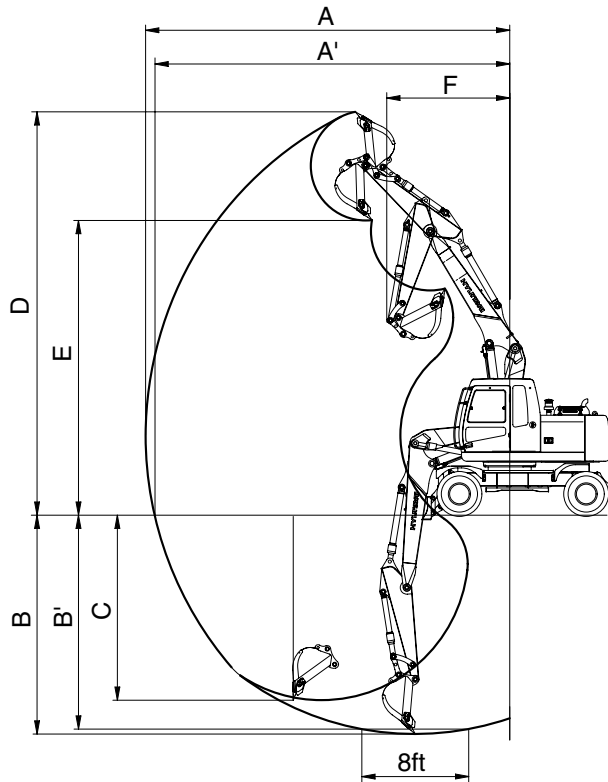

14W7A2SP04

Description		1.9m (6' 3") Arm	2.1m (6' 11") Arm	2.5m (8' 2") Arm
Max digging reach	A	8130mm (26' 8")	8310mm (27' 3")	8720mm (28' 7")
Max digging reach on ground	A'	7920mm (26' 0")	8100mm (26' 7")	8510mm (27' 11")
Max digging depth	B	4790mm (15' 9")	4980mm (16' 4")	5390mm (17' 8")
Max digging depth (8ft level)	B'	4670mm (15' 4")	4870mm (16' 0")	5280mm (17' 4")
Max vertical wall digging depth	C	4030mm (13' 3")	4210mm (13'10")	4650mm (15' 3")
Max digging height	D	9110mm (29' 11")	9220mm (30' 3")	9570mm (31' 5")
Max dumping height	E	6630mm (21' 9")	6740mm (22' 1")	7080mm (23' 3")
Min swing radius	F	2660mm (8' 9")	2810mm (9' 3")	2670mm (8' 9")
Bucket digging force	SAE	83.4 [91] kN	83.4 [91] kN	83.4 [91] kN
		8500 [9270] kgf	8500 [9270] kgf	8500 [9270] kgf
		18740 [20440] lbf	18740 [20440] lbf	18740 [20440] lbf
	ISO	96.1 [104.8] kN	96.1 [104.8] kN	96.1 [104.8] kN
		9800 [10690] kgf	9800 [10690] kgf	9800 [10690] kgf
		21610 [23570] lbf	21610 [23570] lbf	21610 [23570] lbf
Arm digging force	SAE	74.5 [81.3] kN	71.6 [78.1] kN	61.8 [67.4] kN
		7600 [8290] kgf	7300 [7960] kgf	6300 [6870] kgf
		16760 [18280] lbf	16090 [17550] lbf	13890 [15150] lbf
	ISO	78.5 [85.6] kN	75.5 [82.4] kN	64.7 [70.6] kN
		8000 [8730] kgf	7700 [8400] kgf	6600 [7200] kgf
		17640 [19240] lbf	16980 [18520] lbf	14550 [15870] lbf

[] : Power boost

4. WEIGHT

1) MONO BOOM











Item	R140W-7A	
	kg	lb
Upperstructure assembly	4680	10320
Main frame weld assembly	1150	2540
Engine assembly	420	930
Main pump assembly	90	200
Main control valve assembly	80	180
Swing motor assembly	130	290
Hydraulic oil tank assembly	180	400
Fuel tank assembly	140	310
Counterweight	1900	4190
Cab assembly	310	680
Lower frame weld assembly	1340	2950
Swing bearing	220	490
Travel motor assembly	60	130
Turning joint	100	220
Transmission assembly	140	310
Front axle assembly	450	990
Rear axle assembly	380	840
Dozer blade assembly (Front)	590	1300
Dozer blade assembly (Rear)	560	1240
Front attachment assembly (4.6m boom, 2.1m arm, 0.58m ³ SAE heaped bucket)	2380	5250
4.6m boom assembly	800	1760
4.9m adjustable boom assembly	1150	2540
2.1m arm assembly	370	815
0.58m ³ SAE heaped bucket assembly	510	1130
Boom cylinder assembly	130	290
Arm cylinder assembly	160	350
Bucket cylinder assembly	110	240
Bucket control link assembly	80	180
2.5m arm assembly	400	880
Oscillating cylinder assembly	30	70
Front outrigger assembly	800	1765
Rear outrigger assembly	790	1740
Adjustable boom cylinder assembly	120	260
Adjustable cylinder assembly	80	180
Outrigger cylinder assembly	110	240
Blade cylinder assembly (Front)	45	100
Blade cylinder assembly (Rear)	50	110

5. LIFTING CAPACITIES

1) ROBEX 140W-7A











(1) 4.60m (15' 1") boom, 2.1m (6'11") arm equipped with 0.58m³ (SAE heaped) bucket and rear dozer blade down with 1900kg counterweight.

-  : Rating over-front
-  : Rating over-side or 360 degree











Load point height		Load radius								At max. reach		
		1.5m (5ft)		3.0m (10ft)		4.5m (15ft)		6.0m (20ft)		Capacity		Reach
												m (ft)
6.0m (20ft)	kg lb					*2900 *6390	*2900 *6390			*2800 *6170	1960 4320	6.43 (21.1)
4.5m (15ft)	kg lb					*3280 *7230	*3280 *7230	*3120 *6880	2130 4700	*2910 *6420	1530 3370	7.23 (23.7)
3.0m (10ft)	kg lb			*6190 *13650	*6190 *13650	*4190 *9240	3330 7340	*3480 *7670	2050 4520	*3040 *6700	1340 2950	7.59 (24.9)
1.5m (5ft)	kg lb			*8430 *18580	5770 12720	*5180 *11420	3070 6770	*3910 *8620	1940 4280	3180 7010	1300 2870	7.59 (24.9)
Ground Line	kg lb			*8950 *19730	5560 12260	*5780 *12740	2920 6440	*4200 *9260	1860 4100	*3350 *7390	1400 3090	7.24 (23.8)
-1.5m (-5ft)	kg lb	*7320 *16140	*7320 *16140	*8840 *19490	5580 12300	*5780 *12740	2880 6350			*3470 *7650	1710 3770	6.45 (21.2)
-3.0m (-10ft)	kg lb	*11630 *25640	*11630 *25640	*7390 *16290	5740 12650	*4820 *10630	2970 6550					

- Note
1. Lifting capacity are based on SAE J1097 and ISO 10567.
 2. Lifting capacity of the ROBEX series does not exceed 75% of tipping load with the machine on firm, level ground or 87% of full hydraulic capacity.
 3. The load point is a hook located on the back of the bucket.
 4. *i indicates load limited by hydraulic capacity.













(2) 4.60m (15' 1") boom, 1.9m (6' 3") arm equipped with 0.58m³ (SAE heaped) bucket and rear dozer blade down with 1900kg counterweight.

Load point height		Load radius								At max. reach		
		1.5m (5ft)		3.0m (10ft)		4.5m (15ft)		6.0m (20ft)		Capacity		Reach
												m (ft)
6.0m (20ft)	kg lb					*3120 *6880	*3120 *6880			*2920 *6440	2070 4560	6.22 (20.4)
4.5m (15ft)	kg lb					*3470 *7650	*3470 *7650	*2660 *5860	2100 4630	*3020 *6660	1590 3510	7.05 (23.1)
3.0m (10ft)	kg lb			*6620 *14590	6380 14070	*4370 *9630	3310 7300	*3600 *7940	2040 4500	*3150 *6940	1400 3090	7.42 (24.3)
1.5m (5ft)	kg lb			*7370 *16250	5730 12630	*5320 *11730	3070 6770	*4000 *8820	1940 4280	*3300 *7280	1360 3000	7.42 (24.3)
Ground Line	kg lb			*8890 *19600	5580 12300	*5850 *12900	2930 6460	*4230 *9330	1880 4140	*3450 *7610	1470 3240	7.06 (23.2)
-1.5m (-5ft)	kg lb	*7740 *17060	*7740 *17060	*8710 *19200	5630 12410	*5740 *12650	2910 6420			*3530 *7780	1820 4010	6.24 (20.5)
-3.0m (-10ft)	kg lb			*7070 *15590	5810 12810							









(3) 4.60m (15' 1") boom, 2.5m (8' 2") arm equipped with 0.58m³ (SAE heaped) bucket and rear dozer blade down with 1900kg counterweight.

Load point height		Load radius								At max. reach		
		1.5m (5ft)		3.0m (10ft)		4.5m (15ft)		6.0m (20ft)		Capacity		Reach
												m (ft)
6.0m (20ft)	kg lb									*2600 *5730	1710 3770	6.92 (22.7)
4.5m (15ft)	kg lb					*2880 *6350	*2880 *6350	*2860 *6310	2160 4760	*2700 *5950	1370 3020	7.66 (25.1)
3.0m (10ft)	kg lb			*5330 *11750	*5330 *11750	*3820 *8420	3380 7450	*3240 *7140	2070 4560	2820 *6220	1210 2670	8.00 (26.2)
1.5m (5ft)	kg lb			*8040 *17730	5910 13030	*4900 *10800	3110 6860	*3730 *8220	1950 4300	2910 6420	1170 2580	8.00 (26.2)
Ground Line	kg lb	*3740 *8250	*3740 *8250	*8820 *19440	5580 12300	*5650 *12460	2920 6440	*4110 *9060	1860 4100	3100 6830	1250 2760	7.67 (25.2)
-1.5m (-5ft)	kg lb	*6380 *14070	*6380 *14070	*9070 *20000	5540 12210	*5820 *12830	2860 6310	*4140 *9130	1820 4010	*3240 *7140	1490 3280	6.94 (22.8)
-3.0m (-10ft)	kg lb	*9660 *21300	*9660 *21300	*7960 *17550	5650 12460	*5210 *11490	2900 6390			*3210 *7080	2170 4780	5.64 (18.5)









(4) 4.60m (15' 1") boom, 3.0m (9'10") arm equipped with 0.58m³ (SAE heaped) bucket and rear dozer blade down with 1900kg counterweight.

Load point height		Load radius										At max. reach		
		1.5m (5ft)		3.0m (10ft)		4.5m (15ft)		6.0m (20ft)		7.5m (25ft)		Capacity		Reach
														m (ft)
6.0m (20ft)	kg lb							*2060 *4540	*2060 *4540			*2340 *5160	1480 3260	7.46 (24.5)
4.5m (15ft)	kg lb							*2480 *5470	2200 4850			*2450 *5400	1200 2650	8.14 (26.7)
3.0m (10ft)	kg lb					*3300 *7280	*3300 *7280	*2910 *6420	2090 4610	*1740 *3840	1350 2980	*2570 *5670	1070 2360	8.46 (27.8)
1.5m (5ft)	kg lb			*7150 *15760	6110 13470	*4470 *9850	3160 6970	*3460 *7630	1960 4320	*2150 *4740	1290 2840	2630 5800	1040 2290	8.46 (27.8)
Ground Line	kg lb	*3710 *8180	*3710 *8180	*8850 *19510	5620 12390	*5390 *11880	2930 6460	*3940 *8690	1840 4060	*1790 *3950	1240 2730	2780 6130	1090 2400	8.15 (26.7)
-1.5m (-5ft)	kg lb	*5740 *12650	*5740 *12650	*9180 *20240	5490 12100	*5790 *12760	2820 6220	*4140 *9130	1780 3920			*3020 *6660	1280 2820	7.48 (24.5)
-3.0m (-10ft)	kg lb	*8350 *18410	*8350 *18410	*8490 *18720	5540 12210	*5500 *12130	2830 6240					*3110 *6860	1750 3860	6.31 (20.7)
-4.5m (-15ft)	kg lb			*6360 *14020	5780 12740									











(5) 4.90m (16' 9") hydraulic adjustable boom, 1.9m (6' 3") arm equipped with 0.58m³ (SAE heaped) bucket and rear dozer blade down with 1900kg counterweight.

Load point height		Load radius						At max. reach		
		3.0m (10ft)		4.5m (15ft)		6.0m (20ft)		Capacity		Reach
										m (ft)
6.0m (20ft)	kg lb			*2740 *6040	*2740 *6040			*2640 *5820	1780 3920	6.69 (21.9)
4.5m (15ft)	kg lb	*3970 *8750	*3970 *8750	*3230 *7120	*3230 *7120	*2970 *6550	2090 4610	*2730 *6020	1400 3090	7.45 (24.4)
3.0m (10ft)	kg lb			*4160 *9170	3220 7100	*3330 *7340	1990 4390	*2850 *6280	1230 2710	7.80 (25.6)
1.5m (5ft)	kg lb			*5110 *11270	2950 6500	*3760 *8290	1880 4140	*3000 *6610	1200 2650	7.81 (25.6)
Ground Line	kg lb	*6110 *13470	5390 11880	*5650 *12460	2810 6190	*4070 *8970	1800 3970	*3160 *6970	1290 2840	7.46 (24.5)
-1.5m (-5ft)	kg lb	*8550 *18850	5460 12040	*5650 *12460	2800 6170	*4010 *8840	1800 3970	*3270 *7210	1570 3460	6.71 (22.0)
-3.0m (-10ft)	kg lb			*4910 *10820	2910 6420					

(6) 4.90m (16' 9") hydraulic adjustable boom, 2.1m (6'11") arm equipped with 0.58m³ (SAE heaped) bucket and rear dozer blade down with 1900kg counterweight.

Load point height		Load radius						At max. reach		
		3.0m (10ft)		4.5m (15ft)		6.0m (20ft)		Capacity		Reach
										m (ft)
6.0m (20ft)	kg lb			*2560 *5640	*2560 *5640			*2530 *5580	1690 3730	6.91 (22.7)
4.5m (15ft)	kg lb			*3050 *6720	*3050 *6720	*2840 *6260	2110 4650	*2630 *5800	1340 2950	7.64 (25.1)
3.0m (10ft)	kg lb	*6320 *13930	6210 13690	*3990 *8800	3250 7170	*3220 *7100	2000 4410	*2750 *6060	1180 2600	7.98 (26.2)
1.5m (5ft)	kg lb			*4970 *10960	2960 6530	*3680 *8110	1880 4140	*2900 *6390	1140 2510	7.98 (26.2)
Ground Line	kg lb	*6250 *13780	5360 11820	*5580 *12300	2800 6170	*4020 *8860	1790 3950	*3060 *6750	1220 2690	7.65 (25.1)
-1.5m (-5ft)	kg lb	*8670 *19110	5410 11930	*5660 *12480	2770 6110	*4040 *8910	1780 3920	*3200 *7050	1470 3240	6.92 (22.7)
-3.0m (-10ft)	kg lb			*5060 *11160	2860 6310					

(7) 4.90m (16' 9") hydraulic adjustable boom, 2.5m (8' 2") arm equipped with 0.58m³ (SAE heaped) bucket and rear dozer blade down with 1900kg counterweight.

Load point height		Load radius								At max. reach		
		3.0m (10ft)		4.5m (15ft)		6.0m (20ft)		7.5m (25ft)		Capacity		Reach
												m (ft)
6.0m (20ft)	kg lb					*2440 *5380	2200 4850			*2360 *5200	1480 3260	7.38 (24.2)
4.5m (15ft)	kg lb			*2680 *5910	*2680 *5910	*2570 *5670	2150 4740			*2450 *5400	1190 2620	8.07 (26.5)
3.0m (10ft)	kg lb	*5450 *12020	*5450 *12020	*3640 *8020	3310 7300	*2990 *6590	2030 4480	*1970 *4340	1310 2890	*2560 *5640	1060 2340	8.39 (27.5)
1.5m (5ft)	kg lb	*5940 *13100	5630 12410	*4700 *10360	3000 6610	*3500 *7720	1890 4170	*2490 *5490	1260 2780	2680 5910	1030 2270	8.39 (27.5)
Ground Line	kg lb	*6260 *13800	5360 11820	*5430 *11970	2810 6190	*3910 *8620	1780 3920			2830 6240	1090 2400	8.08 (26.5)
-1.5m (-5ft)	kg lb	*8860 *19530	5360 11820	*5670 *12500	2740 6040	*4050 *8930	1750 3860			*2980 *6570	1290 2840	7.40 (24.3)
-3.0m (-10ft)	kg lb	*8020 *17680	5490 12100	*5300 *11680	2790 6150							

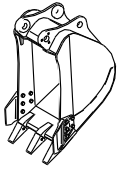
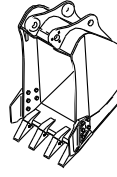
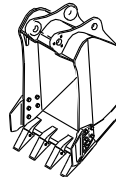
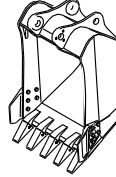
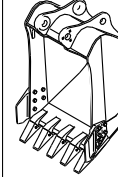
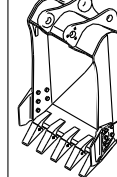
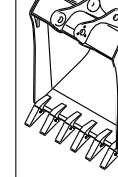

6. BUCKET SELECTION GUIDE

1) GENERAL BUCKET

						
0.23m ³ SAE heaped bucket	0.40m ³ SAE heaped bucket	0.46m ³ SAE heaped bucket	0.52m ³ SAE heaped bucket	※ 0.58m ³ SAE heaped bucket	0.65m ³ SAE heaped bucket	0.71m ³ SAE heaped bucket

Capacity		Width		Weight	Recommendation						
					4.6m (15' 1") Mono boom			4.9m (16' 9") Hyd adjustable boom			
SAE heaped	CECE heaped	Without side cutter	With side cutter		1.9m arm (6' 3")	2.1m arm (6' 11")	2.5m arm (8' 2")	3.0m arm (9' 10")	1.9m arm (6' 3")	2.1m arm (6' 11")	2.5m arm (8' 2")
0.23m ³ (0.30yd ³)	0.20m ³ (0.26yd ³)	520mm (20.5")	620mm (24.4")	335kg (740lb)							
0.40m ³ (0.52yd ³)	0.35m ³ (0.46yd ³)	760mm (29.9")	860mm (33.9")	410kg (900lb)							
0.46m ³ (0.60yd ³)	0.40m ³ (0.52yd ³)	850mm (33.5")	950mm (37.4")	435kg (960lb)							
0.52m ³ (0.68yd ³)	0.45m ³ (0.59yd ³)	935mm (36.8")	1035mm (40.8")	460kg (1010lb)							
※ 0.58m ³ (0.76yd ³)	0.50m ³ (0.65yd ³)	1030mm (40.6")	1130mm (44.5")	480kg (1060lb)							
0.65m ³ (0.85yd ³)	0.55m ³ (0.72yd ³)	1110mm (43.7")	1210mm (47.6")	500kg (1100lb)							
0.71m ³ (0.93yd ³)	0.60m ³ (0.78yd ³)	1205mm (47.4")	-	540kg (1190lb)							

※ : Standard bucket

-  Applicable for materials with density of 2000kg/m³ (3370lb/yd³) or less
-  Applicable for materials with density of 1600kg/m³ (2700lb/yd³) or less
-  Applicable for materials with density of 1100kg/m³ (1850lb/yd³) or less

2) SPECIAL BUCKET

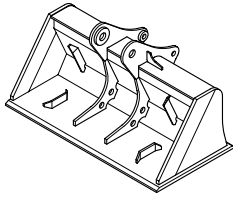
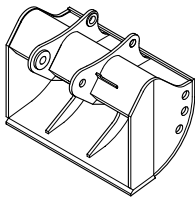
<p>Slope finishing bucket</p> 	<p>Ditch cleaning bucket</p> 
<p>0.55m³ SAE heaped bucket</p>	<p>★0.45m³ SAE heaped bucket</p>

Capacity		Width		Weight	Recommendation					
					4.6m (15' 1") Mono boom			4.9m (16' 9") Hyd adjustable boom		
SAE heaped	CECE heaped	Without side cutter	With side cutter		1.9m arm (6' 3")	2.1m arm (6' 11")	2.5m arm (8' 2")	1.9m arm (6' 3")	2.1m arm (6' 11")	2.5m arm (8' 2")
0.55m ³ (0.72yd ³)	0.45m ³ (0.59yd ³)	1800mm (70.9")	-	585kg (1290lb)						
★0.45m ³ (0.59yd ³)	0.40m ³ (0.52yd ³)	1520mm (59.8")	-	410kg (900lb)						

: Slope finishing bucket

★ : Ditch cleaning bucket

Applicable for materials with density of 2000kgf/m³ (3370lbf/yd³) or less

Applicable for materials with density of 1600kgf/m³ (2700lbf/yd³) or less

Applicable for materials with density of 1100kgf/m³ (1850lbf/yd³) or less

7. SPECIFICATIONS FOR MAJOR COMPONENTS

1) ENGINE

Item	Specification
Model	Mitsubishi D04FD-TAA
Type	4-cycle turbocharged charge air cooled diesel engine
Cooling method	Water cooling
Number of cylinders and arrangement	4 cylinders, in-line
Firing order	1-3-4-2
Combustion chamber type	Direct injection type
Cylinder bore × stroke	102 × 130mm (4.02" × 5.12")
Piston displacement	4249cc (260cu in)
Compression ratio	16.5 : 1
Rated gross horse power (SAE J1995)	119Hp (89kW) at 2000rpm
Maximum torque	45.4kgf · m (328lb · ft) at 1700rpm
Engine oil quantity	18.5 l (4.9U.S. gal)
Dry weight	420kg (930lb)
High idling speed	2100 ± 50rpm
Low idling speed	850 ± 100rpm
Rated fuel consumption	231 ± 7g/kW.hr (170 ± 5g/Ps.hr) at 2000rpm
Starting motor	24V-5.0kW
Alternator	24V-50A
Battery	2 × 12V × 80Ah

2) MAIN PUMP

Item	Specification
Type	Variable displacement tandem axis piston pumps
Capacity	2 × 65cc/rev
Maximum pressure	330kgf/cm ² (4690 psi) [360kgf/cm ² (5120psi)]
Rated oil flow	2 × 130 l /min (34.3U.S. gpm / 28.6U.K. gpm)
Rated speed	2000rpm

[]: Power boost

3) GEAR PUMP

Item	Specification
Type	Fixed displacement gear pump single stage
Capacity	15cc/rev
Maximum pressure	40kgf/cm ² (570psi)
Rated oil flow	30 l /min (8.3U.S. gpm/7.0U.K. gpm)

4) MAIN CONTROL VALVE

Item	Specification
Type	11 spools two-block
Operating method	Hydraulic pilot system
Main relief valve pressure	330kgf/cm ² (4695psi) [360kgf/cm ² (5120psi)]
Overload relief valve pressure	380kgf/cm ² (5540psi)

[]: Poer boost

5) SWING MOTOR

Item	Specification
Type	Fixed displacement axial piston motor
Capacity	64.3cc/rev
Relief pressure	240kgf/cm ² (3414psi)
Braking system	Automatic, spring applied hydraulic released
Braking torque	25kgf · m (181lb · ft)
Brake release pressure	30~50kgf/cm ² (427~711psi)
Reduction gear type	2 - stage planetary

6) TRAVEL MOTOR

Item	Specification
Type	Variable displacement bent-axis axial piston motor
Relief pressure	360kgf/cm ² (5120psi)
Counter balance valve	Applied
Capacity	107cc/rev

7) POWER TRAIN

Item	Description	Specification	
Transmission	Type	2 speed power shift transmission	
	Gear ratio	1st	4.87
		2nd	1.20
Parking brake	Type	Multi disc brake integrated in transmission	
	Maximum braking torque	2124kgf · m (15360lbf · ft)	
Axle	Type	4 wheel drive with differential	
	Gear ratio	15.43	
	Brake	Multi disc brake	

8) REMOTE CONTROL VALVE

Item	Specification	
Type	Pressure reducing type	
Operating pressure	Minimum	6.5kg/cm ² (92psi)
	Maximum	26kg/cm ² (370psi)
Single operation stroke	Lever	61mm (2.4in)

9) CYLINDER

Item	Specification		
Boom cylinder	Bore dia × Rod dia × Stroke	∅ 105 × ∅ 75 × 1075mm	
	Cushion	Extend only	
Arm cylinder	Bore dia × Rod dia × Stroke	∅ 115 × ∅ 80 × 1188mm	
	Cushion	Extend and retract	
Bucket cylinder	Bore dia × Rod dia × Stroke	∅ 100 × ∅ 70 × 855mm	
	Cushion	Extend only	
Dozer cylinder	Rear	Bore dia × Rod dia × Stroke	∅ 100 × ∅ 65 × 236mm
	Front	Bore dia × Rod dia × Stroke	∅ 100 × ∅ 65 × 240mm
	Cushion	Extend only	
Outrigger cylinder	Bore dia × Rod dia × Stroke	∅ 110 × ∅ 75 × 475mm	
	Cushion	-	
Adjust cylinder	Bore dia × Rod dia × Stroke	∅ 145 × ∅ 90 × 613mm	
	Cushion	Extend only	
Adjust boom cylinder	Bore dia × Rod dia × Stroke	∅ 105 × ∅ 75 × 975mm	
	Cushion	Extend only	

10) BUCKET

Item	Capacity		Tooth quantity	Width	
	SAE heaped	CECE heaped		Without side cutter	With side cutter
Standard	※ 0.58m ³ (0.76yd ³)	0.50m ³ (0.65yd ³)	5	1030mm (40.6")	1130mm (44.5")
Option	0.23m ³ (0.30yd ³)	0.20m ³ (0.26yd ³)	3	520mm (20.5")	620mm (24.4")
	0.40m ³ (0.52yd ³)	0.35m ³ (0.46yd ³)	4	760mm (29.9")	860mm (33.9")
	0.46m ³ (0.60yd ³)	0.40m ³ (0.52yd ³)	4	850mm (33.5")	950mm (37.4")
	0.52m ³ (0.68yd ³)	0.45m ³ (0.59yd ³)	5	935mm (36.8")	1035mm (40.8")
	0.65m ³ (0.85yd ³)	0.55m ³ (0.72yd ³)	5	1110mm (43.7")	1210mm (47.6")
	0.71m ³ (0.93yd ³)	0.60m ³ (0.78yd ³)	6	1205mm (47.4")	-
	0.55m ³ (0.72yd ³)	0.45m ³ (0.59yd ³)	-	1800mm (70.9")	-
	★0.45m ³ (0.59yd ³)	0.40m ³ (0.52yd ³)	-	1520mm (59.8")	-

※ : Slope finishing bucket

★ : Ditch cleaning bucket

8. RECOMMENDED OILS

Use only oils listed below or equivalent.
Do not mix different brand oil.

Service point	Kind of fluid	Capacity l (U.S. gal)	Ambient temperature °C(°F)						
			-20 (-4)	-10 (14)	0 (32)	10 (50)	20 (68)	30 (86)	40 (104)
Engine oil pan	Engine oil	18.5 (4.9)				SAE 30			
				SAE 10W					
Transmission case		3.0 (0.8)	SAE 10W-30						
			SAE 15W-40						
Swing drive	Gear oil	2.5 (0.7)	SAE 85W-140						
	Grease	0.32 (0.1)	NLGI NO.1			NLGI NO.2			
Front axle	Gear oil	Center : 7.8 (2.1) Hub : 1.2×2 (0.32×2)	SAE 85W-90						
Rear axle		Center : 8.4 (2.2) Hub : 1.2×2 (0.32×2)							
Hydraulic tank	Hydraulic oil	Tank: 124 (32.7) System: 240 (63.4)	ISO VG 32				ISO VG 46		
			ISO VG 68						
Fuel tank	Diesel fuel	270 (71.3)	ASTM D975 NO.1			ASTM D975 NO.2			
Fitting (Grease nipple)	Grease	As required	NLGI NO.1			NLGI NO.2			
Radiator (Reservoir tank)	Mixture of antifreeze and water 50 : 50	22 (5.8)	Ethylene glycol base permanent type						

SAE : Society of Automotive Engineers
API : American Petroleum Institute
ISO : International Organization for Standardization
NLGI : National Lubricating Grease Institute
ASTM : American Society of Testing and Material