

GROUP 2 ENGINE SYSTEM

ENGINE AND ACCESSORIES MOUNTING

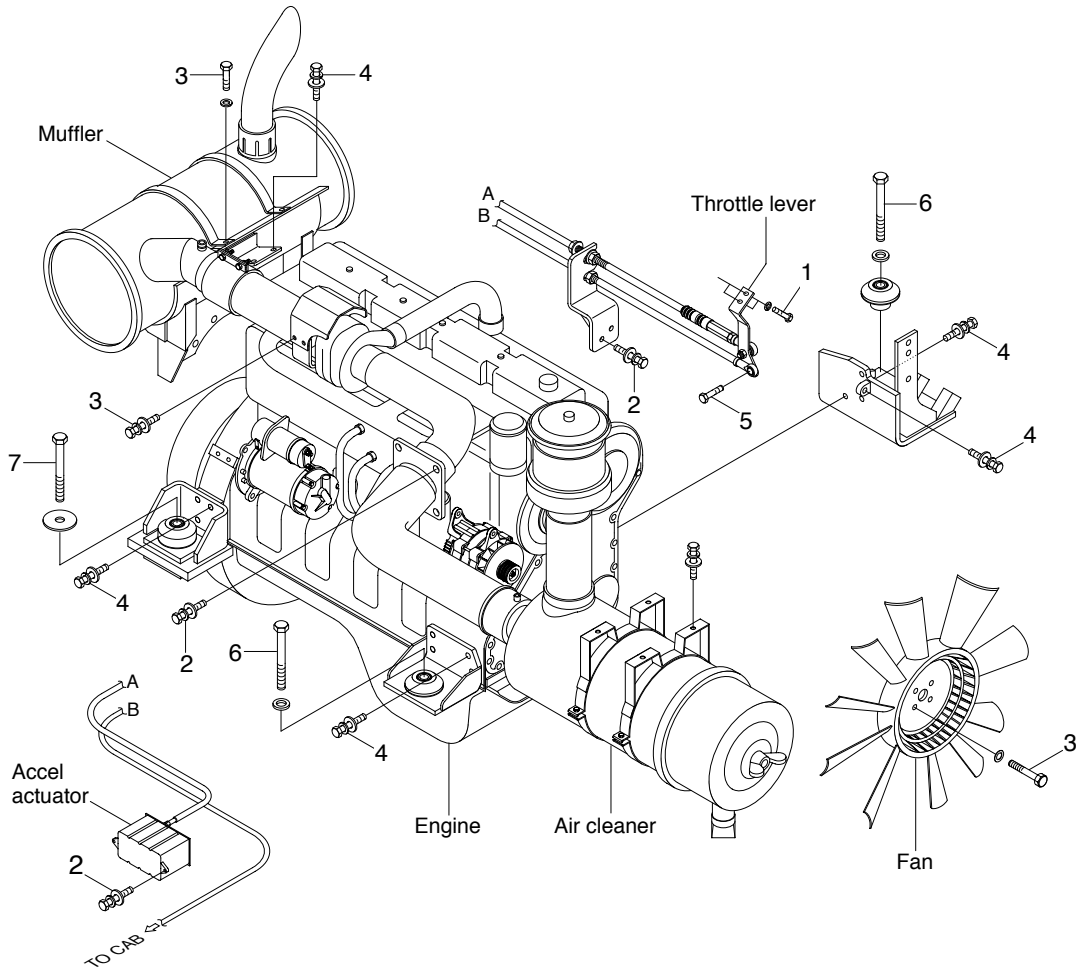

14W79CM01

· Tightening torque

Item	Size	kgf · m	lbf · ft
1	M 6 × 1.0	0.92 ± 0.2	6.7 ± 1.4
2	M 8 × 1.25	2.5 ± 0.5	18.1 ± 3.6
3	M10 × 1.5	4.4 ± 0.9	31.8 ± 6.5
4	M10 × 1.5	6.9 ± 1.4	49.9 ± 10.1
5	M12 × 1.5	12.5 ± 3.0	92.6 ± 21.7

Item	Size	kgf · m	lbf · ft
6	M12 × 1.75	10.0 ± 2.0	72.3 ± 14.5
7	M12 × 1.75	12.8 ± 3.0	92.6 ± 21.7
8	M20 × 2.5	55 ± 3.5	398 ± 25.3
9	M24 × 3.0	90 ± 7.0	651 ± 51
-	-	-	-

COOLING SYSTEM AND FUEL TANK MOUNTING

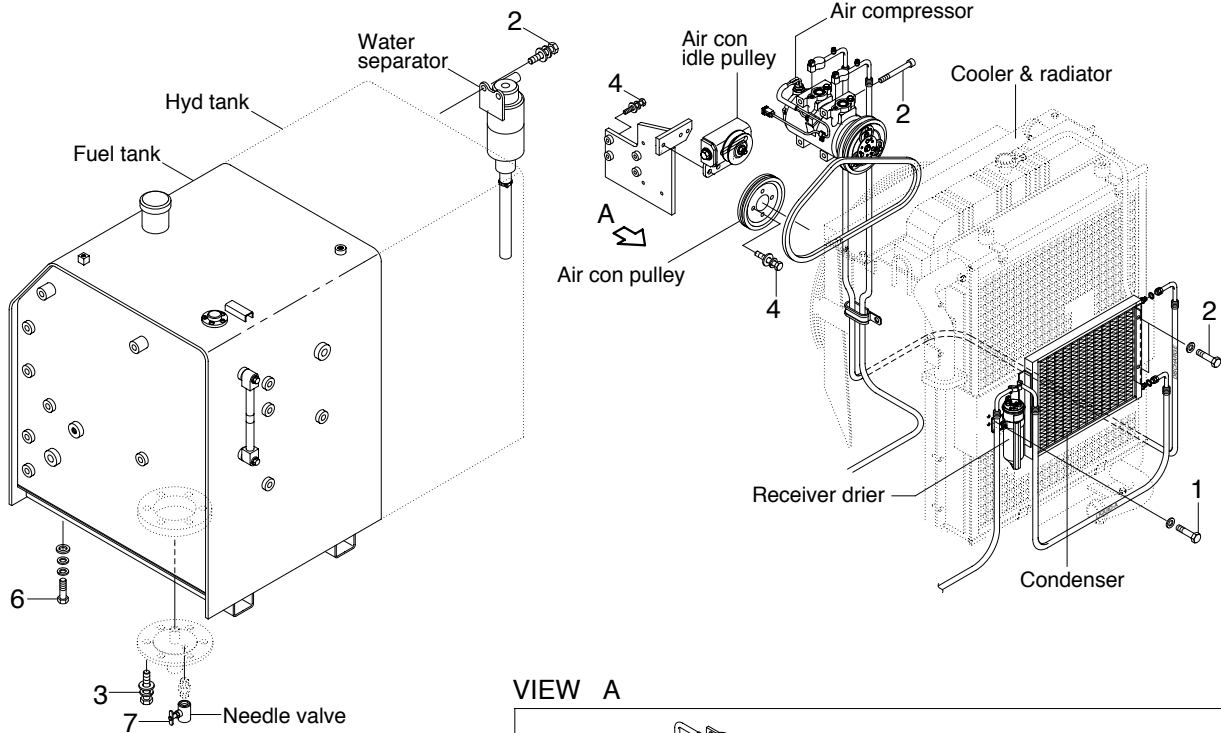

VIEW A

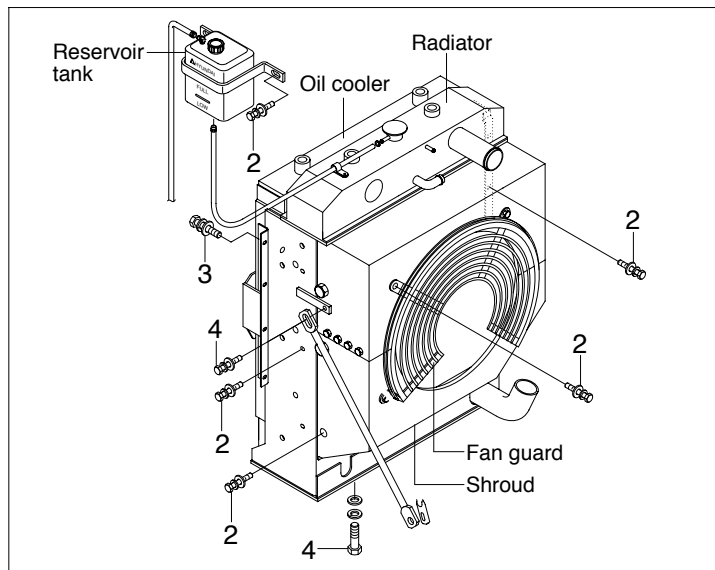

14W79CM02

· Tightening torque

Item	Size	kgf · m	lbf · ft
1	M 6 × 1.0	1.05 ± 0.2	7.6 ± 1.45
2	M 8 × 1.25	2.5 ± 0.5	18.1 ± 3.6
3	M10 × 1.5	6.9 ± 1.4	49.9 ± 10.1

Item	Size	kgf · m	lbf · ft
4	M12 × 1.75	12.8 ± 3.0	92.6 ± 21.7
5	M20 × 2.5	46 ± 5.1	333 ± 36.9
6	-	2.3 ± 0.6	16.6 ± 4.3