

## GROUP 9 FRONT AXLE AND REAR AXLE

### 1. REMOVAL FRONT AXLE

- 1) Front axle mounting bolt(1, M20)
  - Tightening torque :  $57.9 \pm 8.7\text{kgf} \cdot \text{m}$   
( $419 \pm 63\text{lb} \cdot \text{ft}$ )
- 2) Propeller shaft mounting nut(1, M10)
  - Tightening torque :  $5.9 \pm 0.6\text{kgf} \cdot \text{m}$   
( $42.7 \pm 4.3\text{lb} \cdot \text{ft}$ )
- 3) Wheel nut(2, M22)
  - Tightening torque :  $62 \pm 3\text{kgf} \cdot \text{m}$   
( $448 \pm 21.7\text{lb} \cdot \text{ft}$ )
- 4) Oscillating cylinder supporting mounting bolt(3, M16)
  - Tightening torque :  $12.3 \pm 2.5\text{kgf} \cdot \text{m}$   
( $88.9 \pm 18.1\text{lb} \cdot \text{ft}$ )
- 5) Pipe assy(4)
- 6) Hose assy(5)
- 7) Front axle weight : 445kg(980lb)

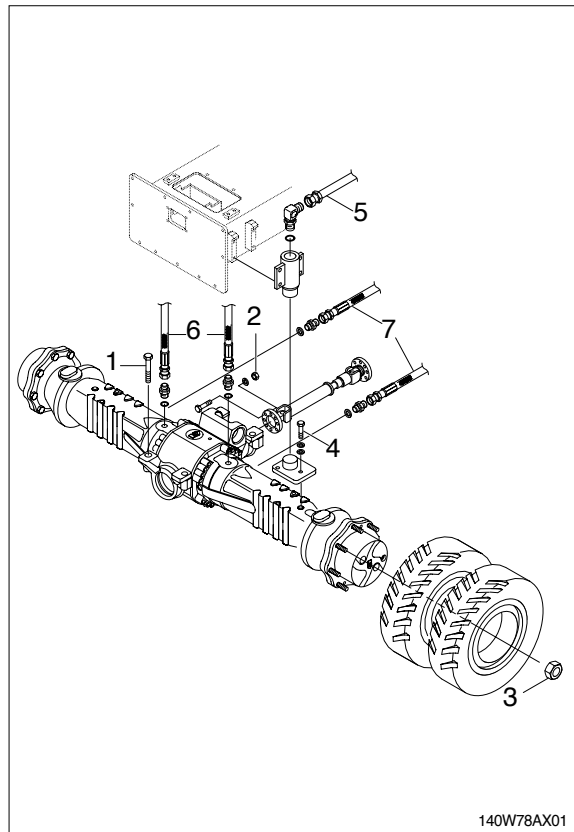

### 2. REMOVAL REAR AXLE

- 1) Rear axle mounting bolt and nut(1, M20)
  - Tightening torque :  $58 \pm 6.3\text{kgf} \cdot \text{m}$   
( $420 \pm 45.6\text{lb} \cdot \text{ft}$ )
- 2) Propeller shaft mounting nut(2, M10)
  - Tightening torque :  $5.9 \pm 0.6\text{kgf} \cdot \text{m}$   
( $42.7 \pm 4.3\text{lb} \cdot \text{ft}$ )
- 3) Wheel nut(3)
  - Tightening torque :  $62 \pm 3\text{kgf} \cdot \text{m}$   
( $448 \pm 21.7\text{lb} \cdot \text{ft}$ )
- 4) Hose assy(4)
- 5) Rear axle weight : 380kg(840lb)

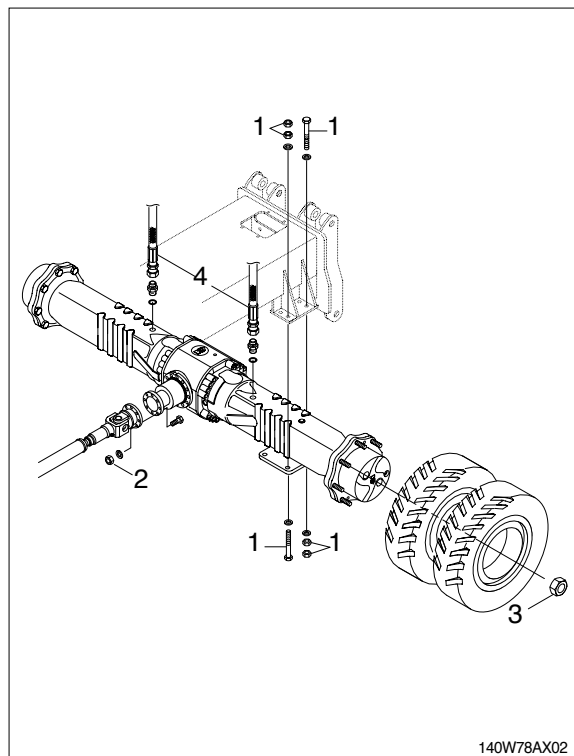

### 3. GENERAL INSTRUCTIONS

- 1) During all operations described in this manual, the axle should be fastened onto a trestle, while the other parts mentioned should rest on supporting benches.
- 2) When removing one of the arms, an anti-tilting safety trestle should be placed under the other arm.
- 3) When working on an arm that is fitted on the machine, make sure that the supporting trestles are correctly positioned and that the machine is locked lengthways.
- 4) Do not admit any other person inside the work area; mark off the area, hang warning signs and remove the ignition key from the machine.
- 5) Use only clean, quality tools; discard all worn, damaged, low-quality or improvised wrenches and tools. Ensure that all dynamometric wrenches have been checked and calibrated.
- 6) Always wear gloves and non-slip rubber shoes when performing repair work.
- 7) Should you stain a surface with oil, remove marks straight away.
- 8) Dispose of all lubricants, seals, rags and solvents once work has been completed. Treat them as special waste and dispose of them according to the relative law provisions obtaining in the country where the axles are being overhauled.
- 9) Make sure that only weak solvents are used for cleaning purposes; avoid using turpentine, dilutants and toluol-, xylo- based or similar solvents; use light solvents such as kerosene, mineral spirits or water-based, environment friendly solvents.
- 10) For the sake of clarity, the parts that do not normally need to be removed have not been reproduced in some of the diagrams.
- 11) The terms RIGHT and LEFT in this manual refer to the position of the operator facing the axle from the side opposite the drive.
- 12) After repair work has been completed, accurately touch up any coated part that may have been damaged.

## 4. CHECKING WEAR AND REPLACING THE BRAKING DISKS

### 1) HOW TO DISASSEMBLE THE BRAKING UNIT

- (1) Remove the oil-level plug(1).

**Perform all operations on both arms.**

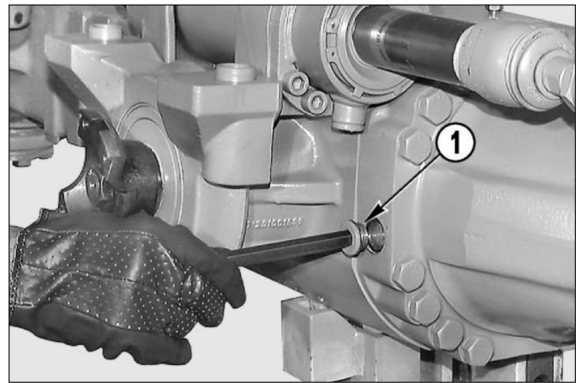

14W7FA002

- (2) Apply the brakes and keeping them under pressure, check the linings "S" between the disk using tool T1.

Minimum "S" : 4.5mm

**Replace the braking disks and the intermediate disks on both sides if necessary.**

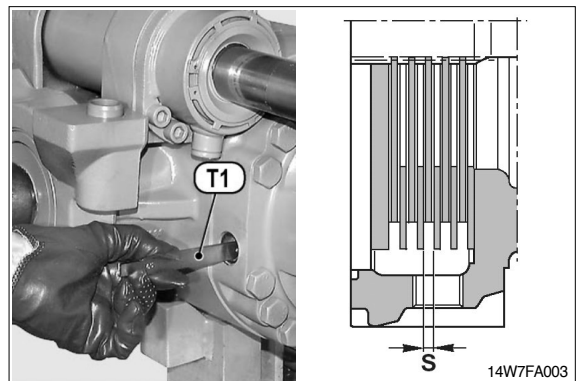

14W7FA003

- (3) Remove the swinging support(2) on the side opposite the drive.

#### **NOTE**

If the bushing(17) is worn and needs replacing, note down the assembly side of the connection notch " A ".

**Front axle only**

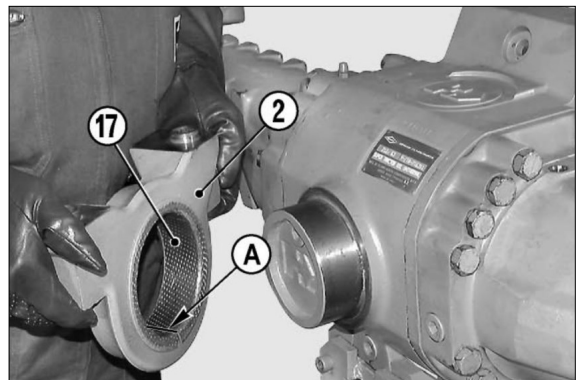

14W7FA004

- (4) Disconnect the pins of the steering bare from the steering case (See " HOW TO REMOVE THE STEERING CYLINDER "). Sling the arm(3) to be removed and put the rod under slight tension.

**Front axle only**

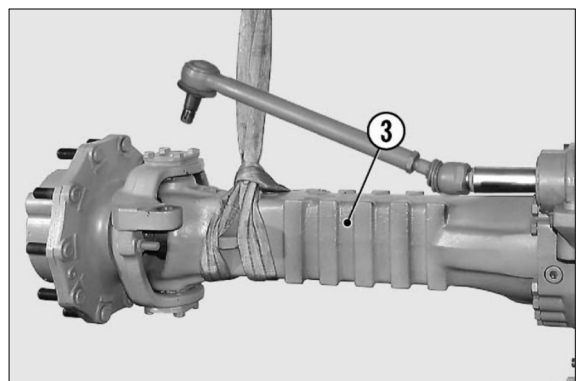

14W7FA005

- (5) Unloose and remove the screws(4) and the washers(5) that fix the arm(3) to the central body(6).

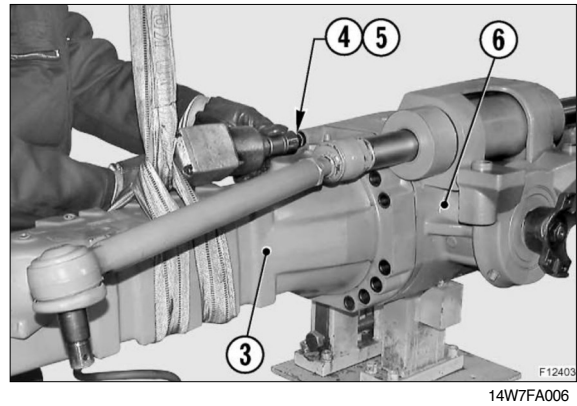

- (6) Remove the arm(3) together with the pack of the braking disks(7). Place the arm on a bench.

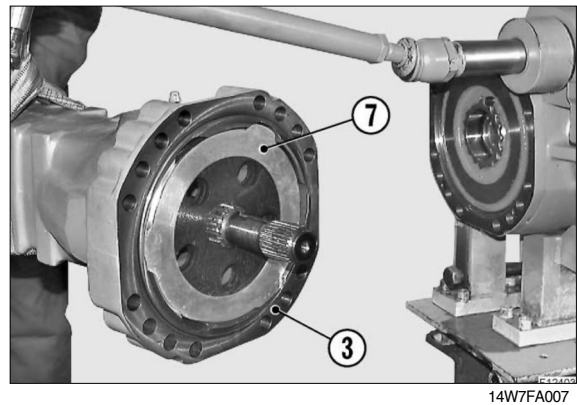

- (7) Remove the braking disks(7) and note down their order of assembly.

**NOTE**

If the disks do not need replacing, avoid switching their position.  
Extract the u-joint(18).

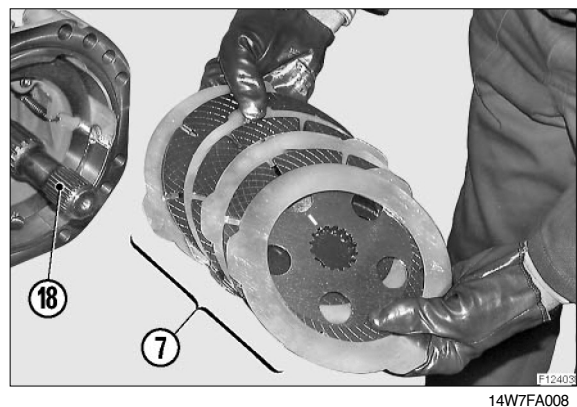

- (8) Remove the reversal springs(8) from the piston(9).

**NOTE**

If the springs(8) are weak or deformed they must be replaced.

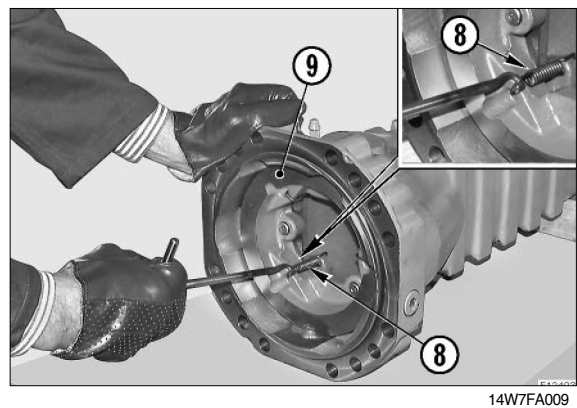

(9) Remove the pin screws(10) guiding the piston(9).

**If the screws are to be replaced, note down the different colours for the different brake gap.**

**(See “ HOW TO ASSEMBLE THE BRAKING UNITS ”)**

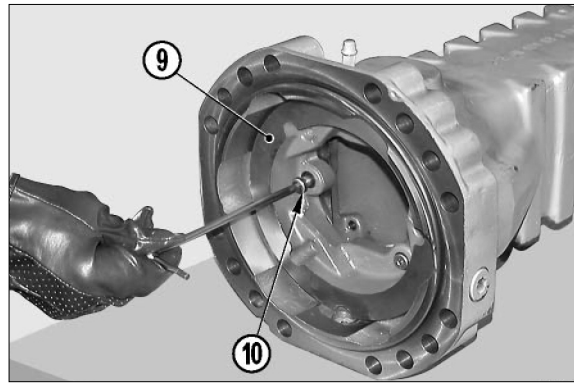

14W7FA010

(10) Slowly introduce compressed air through the connection of the braking circuit in order to extract the entire piston.

**Hold on to the piston as it may be suddenly ejected and damaged.**

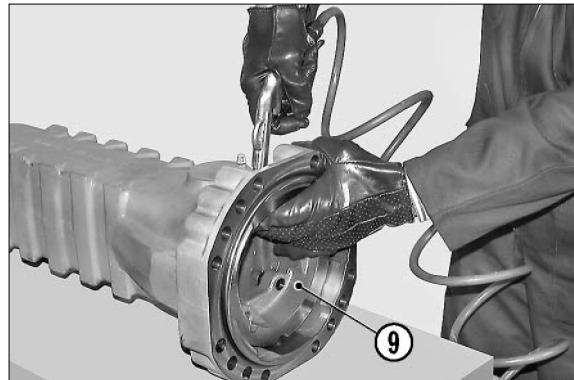

14W7FA011

## 2) HOW TO ASSEMBLE THE BRAKING UNITS

- (1) Accurately clean the piston(9) and the seats of slide and seal.

Replace the O-rings(11) and (12) and the anti-extrusion rings(13) and (14); make sure that the assembly side is correct.

**Accurately check the positioning of the anti-extrusion rings(13) and (14).**

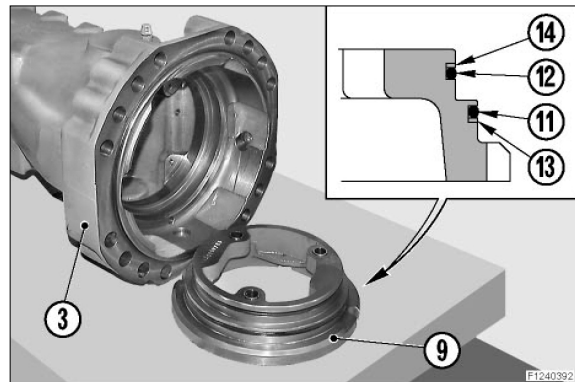

- (2) Insert the stroke automatic regulation springs(15); place them in line with the piston(9).

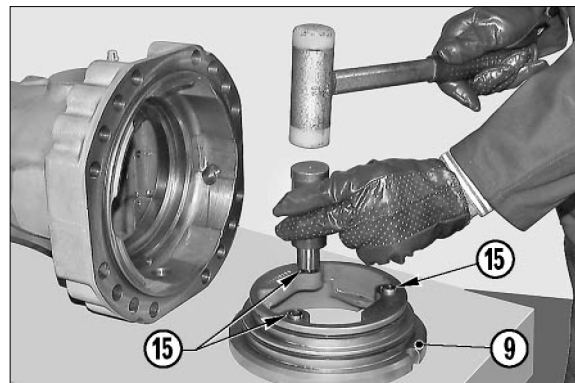

- (3) Lubricate the seals(11) and (12) and fit the piston(9) into the arm(3).

**Make sure that the piston seat fits into the stop pin(A) inside the arm.**

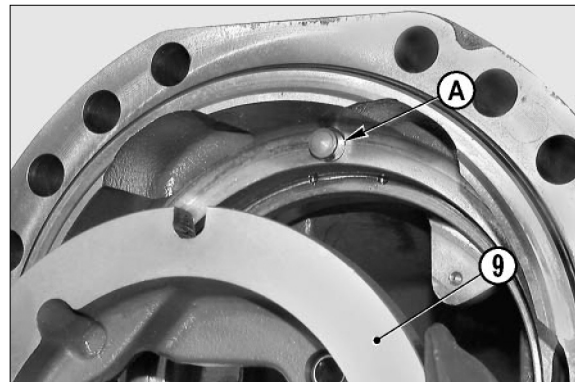

- (4) Assist the insertion of the piston(9) by lightly hammering around the edge with a plastic hammer.

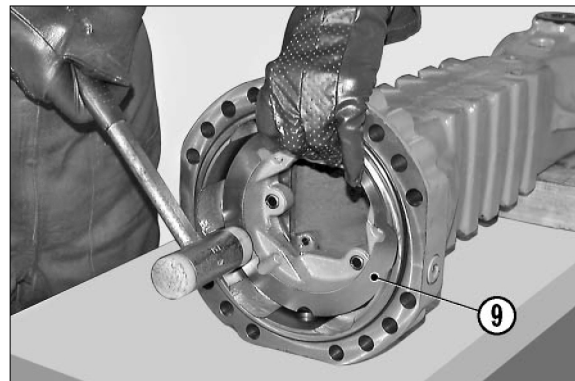

- (5) Fit the pin screws(10) making sure that they are all of the same colour.

White : 1mm gap

Yellow : 0.75mm gap

Blue : 0.5mm gap

Apply loctite 270 to the thread.

- Torque wrench setting : 0.5~0.7kgf · m  
(3.7~5.2lbf · ft)

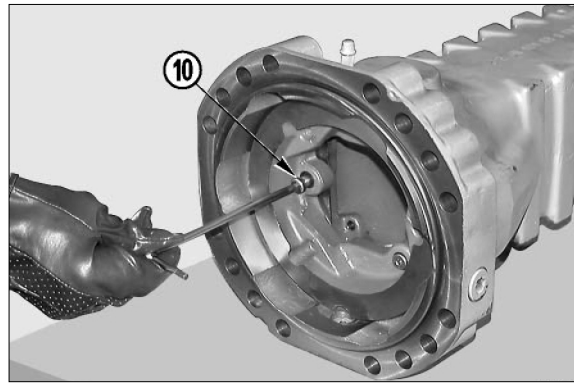

14W7FA017

- (6) Fit the reversal springs(8) on the piston(9).  
**Pay due attention not to deform the connections of the springs.**

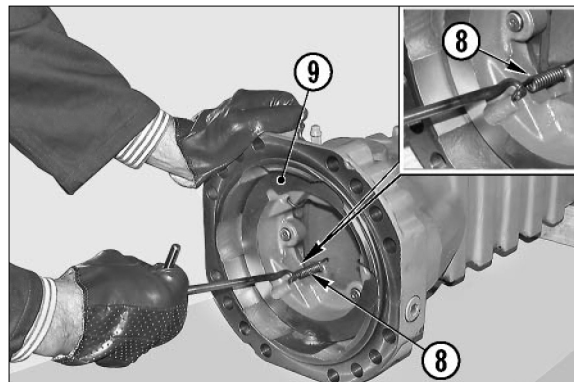

14W7FA018

- (7) Slightly lubricate the braking disks(7) and fit them in the arm following the correct sequence; orient them so that the oil circulation holes and the marks " B " are perfectly lined up.

**NOTE**

When installing the steel discs, the slot corresponding to the oil level cap should always be kept free.

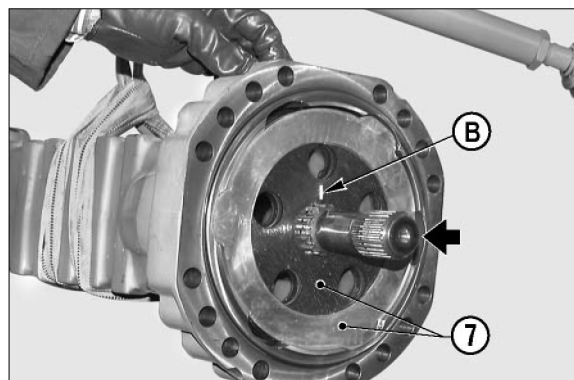

14W7FA019

- (8) Check that the positioning of the sealing ring(16) on the arm is intact; install the complete arm. Lock it into position using two facing screws(4) and washers(5).

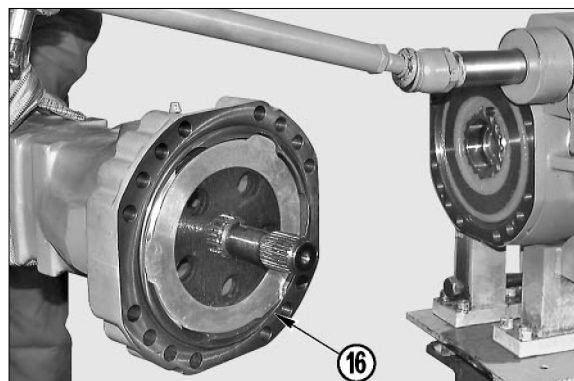

14W7FA020

(9) Check the flatness of the arms using tool T2 and finally lock the arms with the screws(4) and the washer(5) using the cross-tightening method.

- Torque wrench setting : 30kgf · m(219lbf · ft)

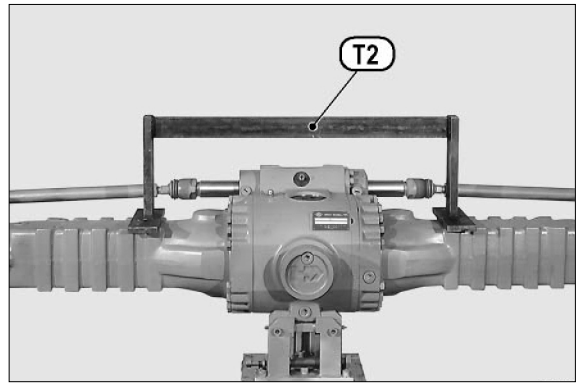

14W7FA021

## 5. STEERING CASE

### FRONT AXLE ONLY

#### 1) HOW TO REMOVE THE COMPLETS STEERING CASE

- (1) Unloose and remove the fittin screws(15), (8) from the articulation pin(19), (4).

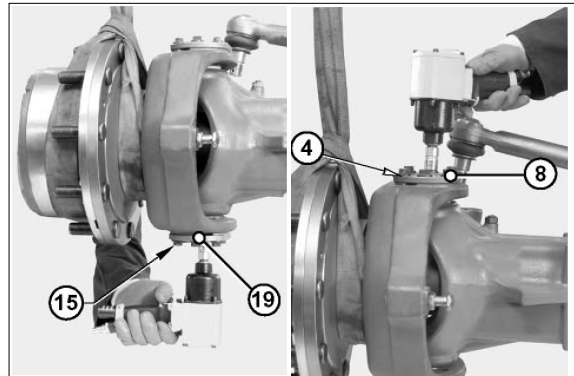

14W7FA023

- (2) Remove the bottom articulation(19) pin complete with front sealing ring(10).

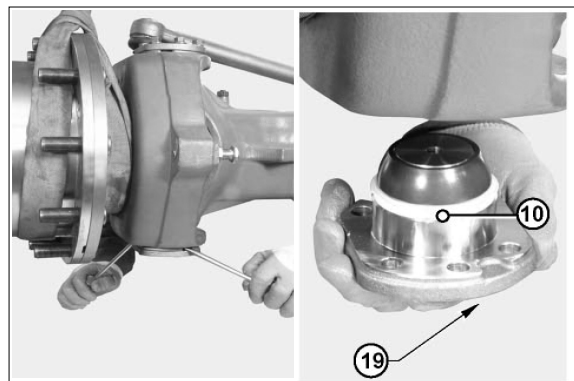

14W7FA024

- (3) Using two levers, remove the top articulation pin(4) complete with front seal(9) and shims(3).  
Pay attention not to damage the surfaces.

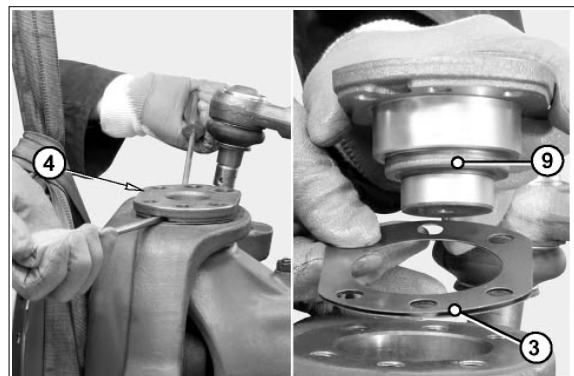

14W7FA025

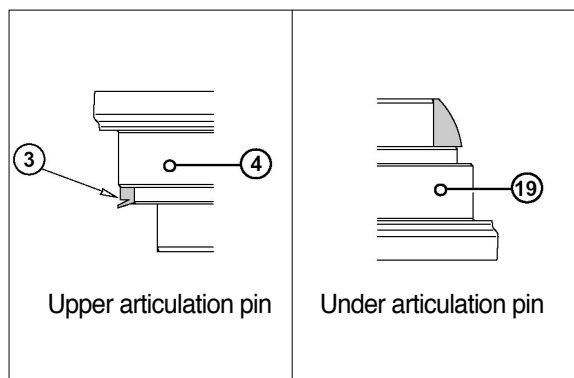

14W7FA026

(4) Remove the complete steering case(1).

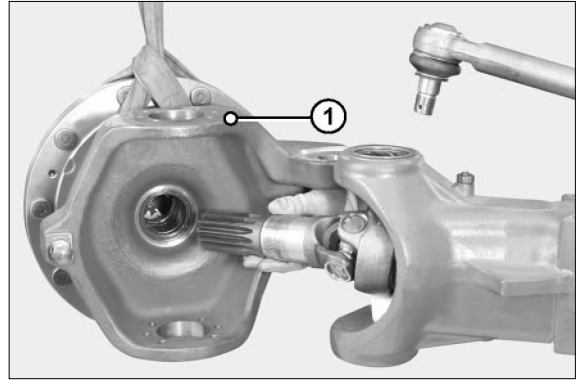

14W7FA027

## 2) HOW TO INSTALL THE COMPLETE STEERING CASE

- (1) Lubricate the terminal of the u-joint and install the steering case(1).

Pay due attention not to damage the dust cover rings and the sealing rings.

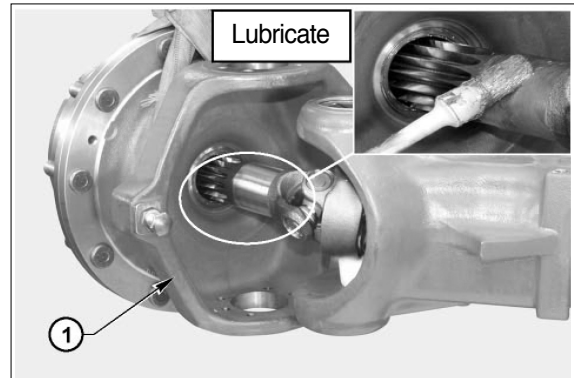

14W7FA028

- (2) Prepare a series of shims(3) of 0.85mm. To be assembled under the upper pin(4).

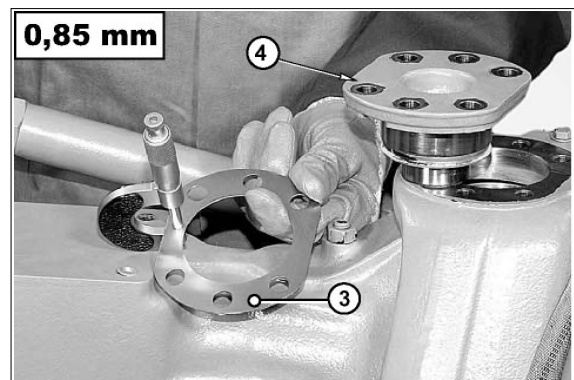

14W7FA029

- (3) Fit a new seal(3) onto the top articulation pin(4). Lubricate and install the unit in the steering case. Position the screws(8) and tight wrench 14kgf · m(101lbf · ft). Check the correct assembly side of the seal(3).

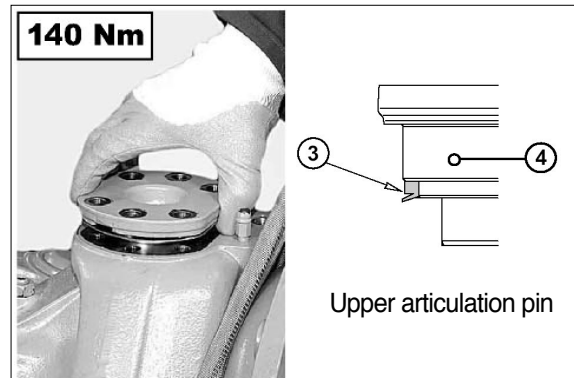

14W7FA030

- (4) Lubricate and the unit in the steering case.



14W7FA031

- (5) Fit the unit(19) in the steering case(1).  
Position the screws(15) and tightly tighten.  
Check for the correct assembly side of the seal(10)

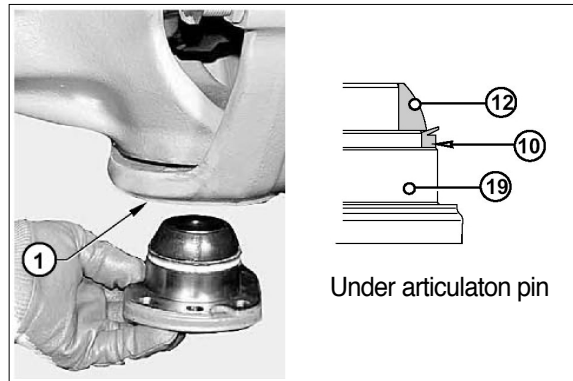

14W7FA032

- (6) Tighten the new fitting screws(15) of top and bottom articulation pins in sequence using the cross tightening method.  
· Torque wrench setting : 14kgf · m(101lb · ft)

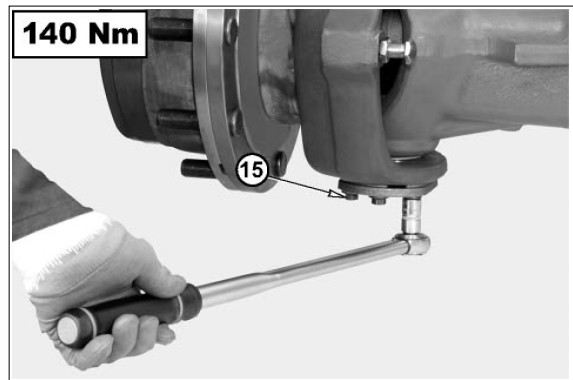

14W7FA033

- (7) Check by means of a lever that there is no vertical gap. In case there is any gap, determine the width and reduce it by removing shims.



14W7FA034

- (8) Check the torque of the pins, which has to be between 3~6kgf · m(2.2~4.4lb · ft).  
If the preliminary measured value is too high, the shims have to be increased.

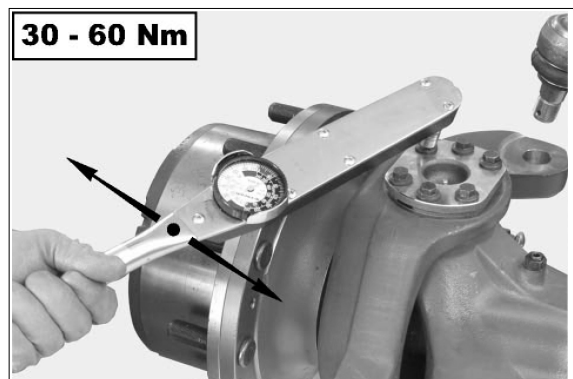

14W7FA035

## 6. U-JOINT

### FRONT AXLE ONLY

#### 1) HOW TO REMOVE THE U-JOINT

- (1) Unloose and remove the top and bottom check nuts(2) from the dowels(3).

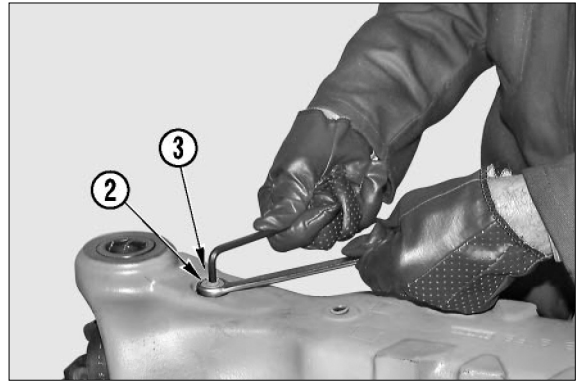

14W7FA036

- (2) Remove top and bottom check dowels(3) from the bush(13).

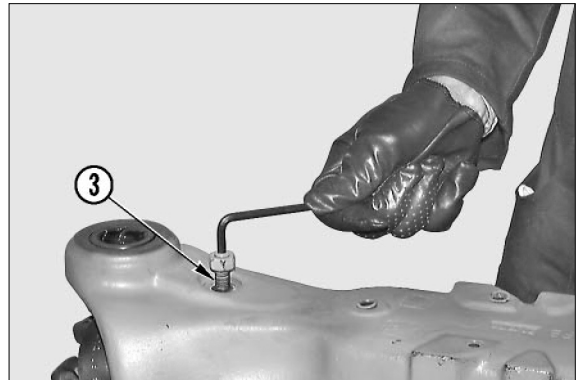

14W7FA037

- (3) Remove the entire u-joint(4).

#### NOTE

To remove the u-joint use, if necessary, a plastic hammer or a lever.

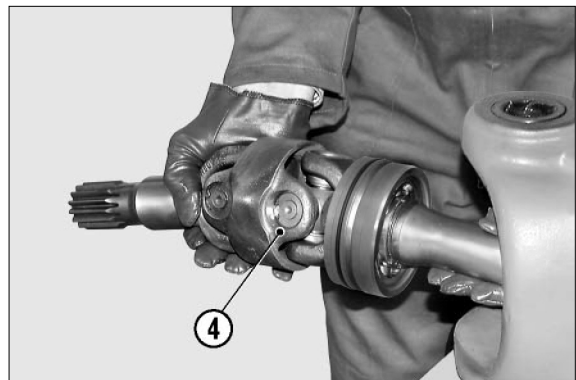

14W7FA042

- (4) Remove the snap ring(9) from the bushing unit(13).

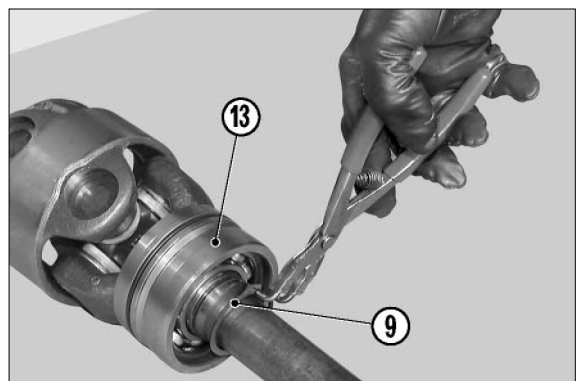

14W7FA043

- (5) Position the entire u-joint(4) under a press and remove the complete bush(13).

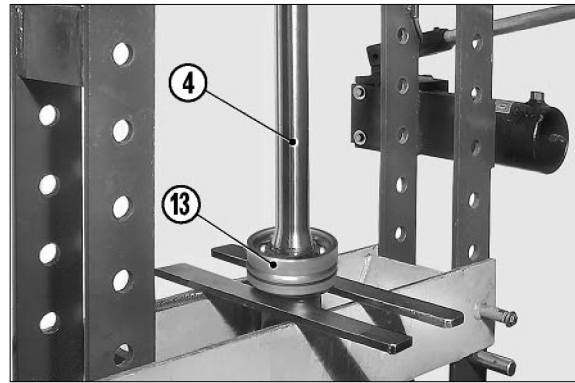

14W7FA044

- (6) Remove the snap ring(10) from the bearing(11). Use a puller to remove the bearing(11), the sealing ring(12) and the O-ring(14).

**NOTE**

Note down the assembly side of the ring(12).

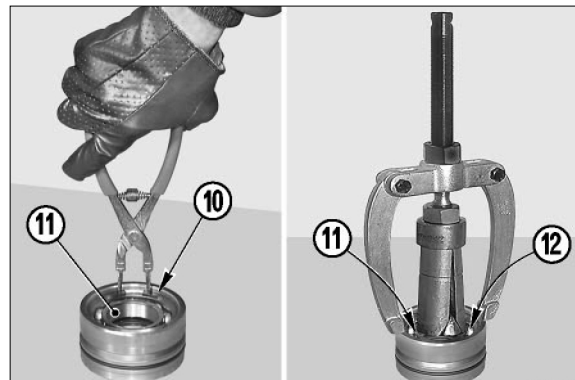

14W7FA045

## 2) INSTALLATION OF U-JOINT

- (1) Using tools T5 and T6, insert the sealing ring(12) and the bearing(11) in the bush(13).

### NOTE

Carefully check the assembly side of the seal(12).

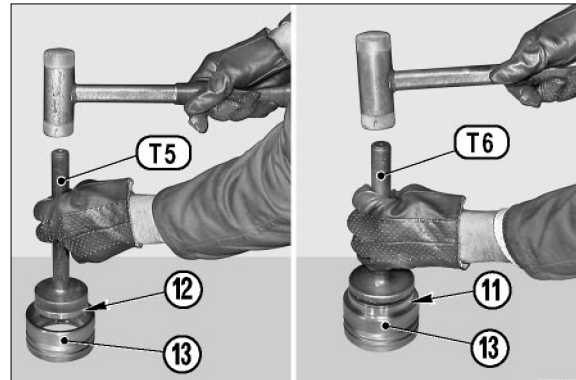

- (2) Fit the snap ring(10) on the bearing(11).

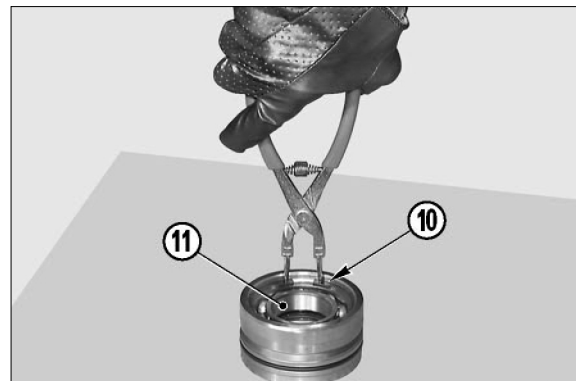

- (3) Heat the bearing in oil at an approx. temperature of 100°C and fit the entire bush(13) on the u-joint(4).

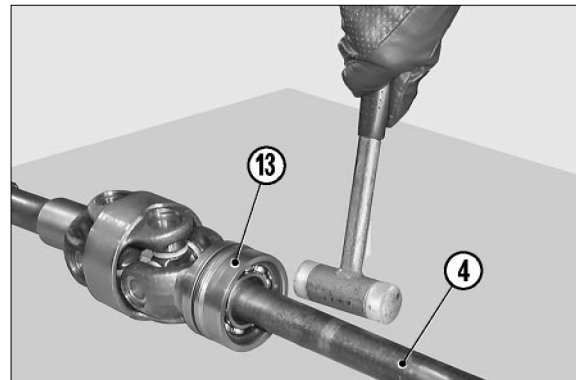

- (4) Fit the check ring(9) on the bushing unit(13); also put the O-ring(14) into position.

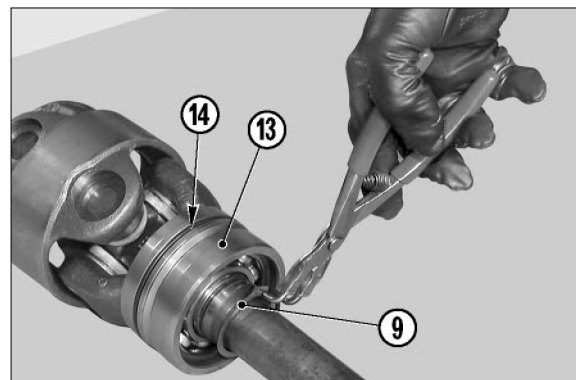

(5) Insert the u-joint and tighten the top and bottom dowels(2).

- Torque wrench setting : Max 1.5kgf · m  
(11lbf · ft)

**NOTE**

For u-joint coming with a bush, centre the point of the check dowels in the slot.

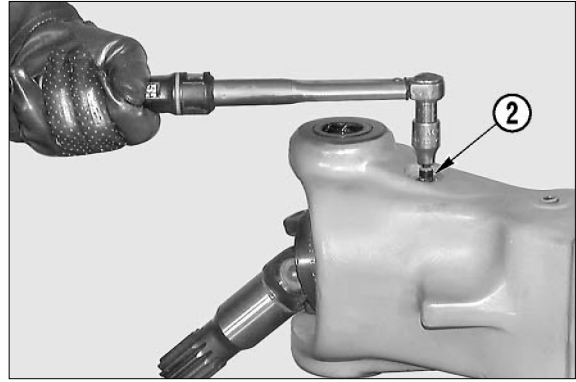

14W7FA054

(6) Apply loctite 242 to the jutting parts of the dowels(2).

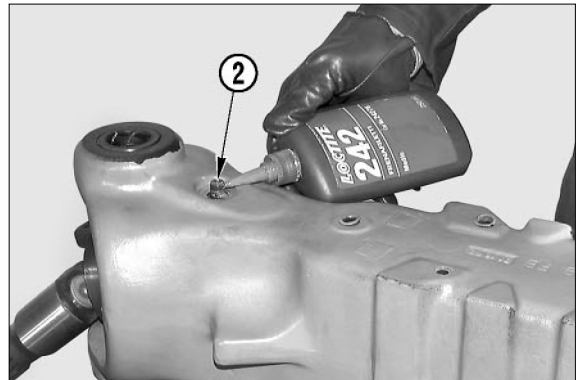

14W7FA055

(7) Screw the check nuts(3) of the dowels(2) and lock them using a dynamometric wrench.

- Torque wrench setting : 12.4kgf · m(90lbf · ft)

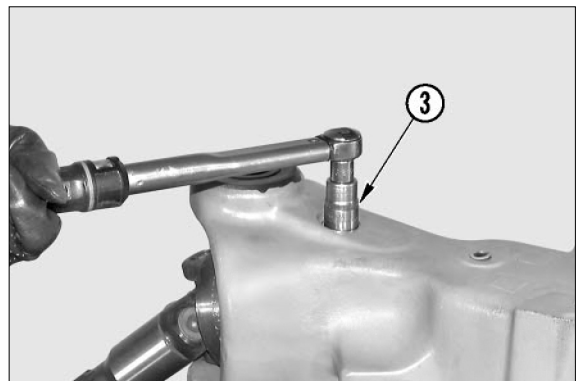

14W7FA056

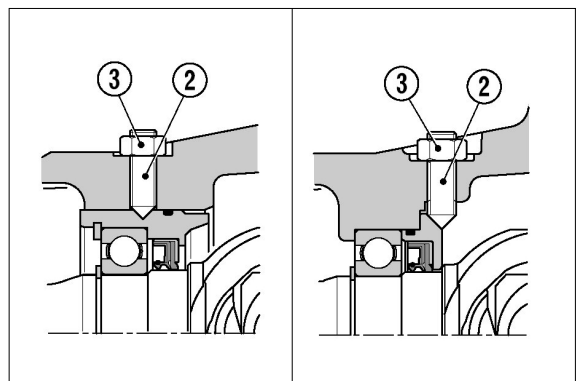

14W7FA057

## 7. THE PLANETARY REDUCTION

### 1) HOW TO DISASSEMBLE THE PLANETARY REDUCTION

- (1) Disconnect the steering bars from the steering case(3).

For details, see " HOW TO REMOVE THE COMPLETE STEERING CASE ".

#### **Front axle only.**

Remove the securing screws(1) from the planetary carrier cover(2).

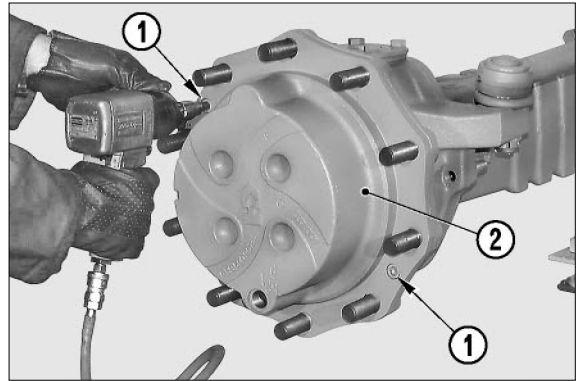

14W7FA058

- (2) Disjoint the planetary carrier cover(2) from the steering case(3) by alternatively forcing a screwdriver into the appropriate slots.

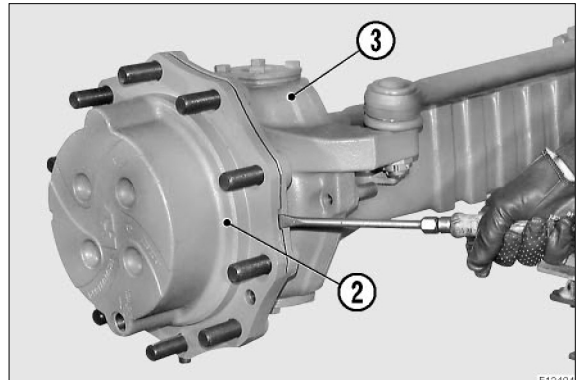

14W7FA059

- (3) Remove the complete planetary carrier cover(2).

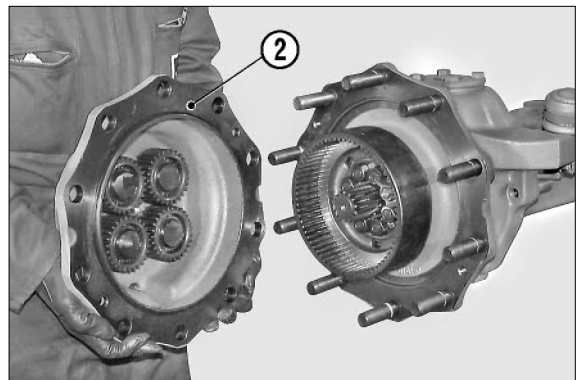

14W7FA060

- (4) Remove the complete axle shaft(4).  
**Rear axle only.**



14W7RA024

- (5) Unloose and remove the tightening nuts(4) from the crown flange(5).

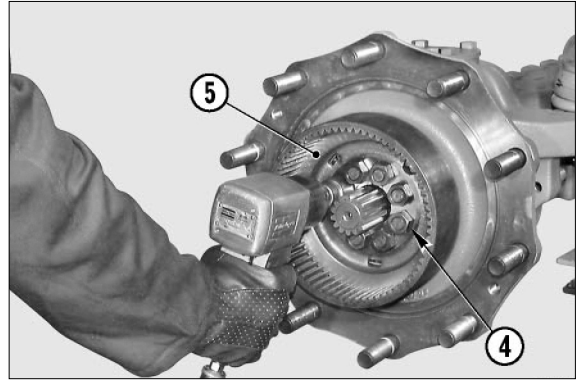

14W7FA061

- (6) Remove the safety flange(6).

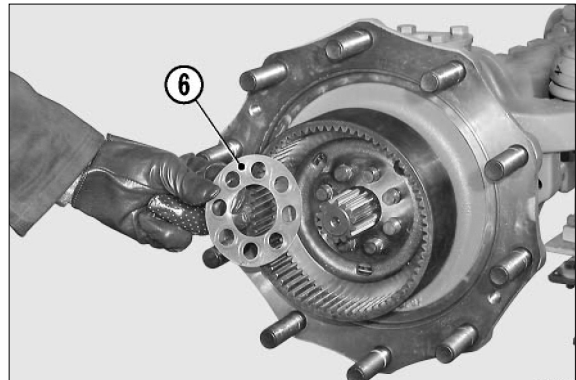

14W7FA062

- (7) Using a puller, remove the complete crown flange(5) by acting on the stud bolts.

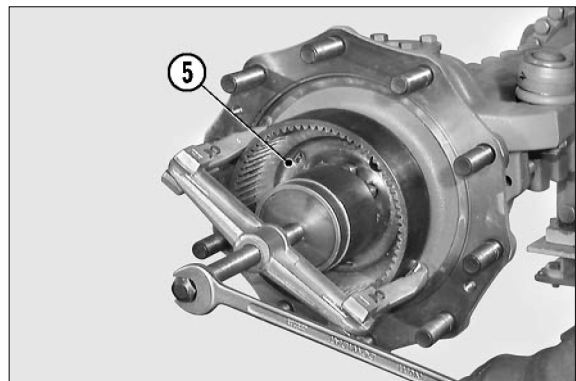

14W7FA063

- (8) Partially extract the hub(7) using a plastic hammer.

**NOTE**

Alternately hammer on several equidistant points.

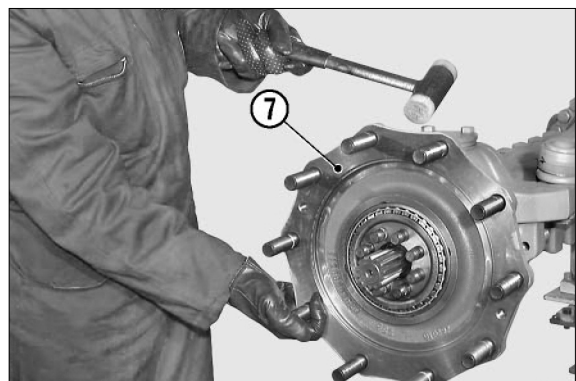

14W7FA064

(9) Remove the external bearing(8).

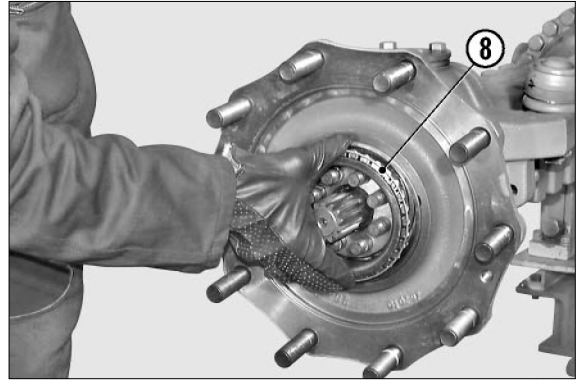

14W7FA065

(10) By hand remove the complete hub(7).  
**Front axle only**

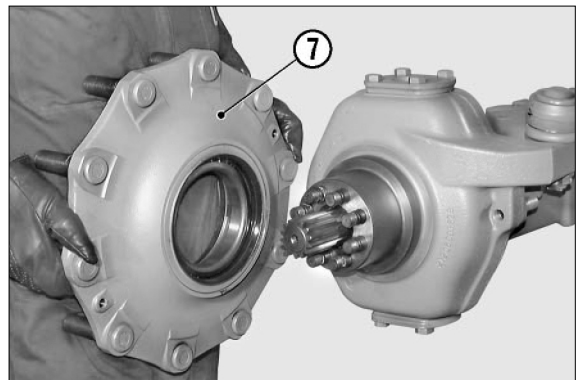

14W7FA066

(11) Remove the pins and remove the steering case(3).  
For details, see " HOW TO REMOVE  
THE COMPLETE STEERING CASE ".  
**Front axle only.**

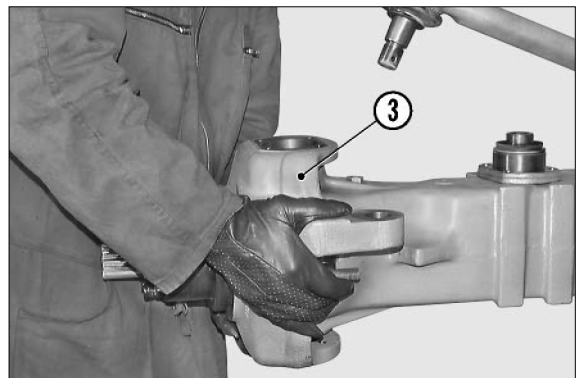

14W7FA067

(12) Remove the snap rings(9).

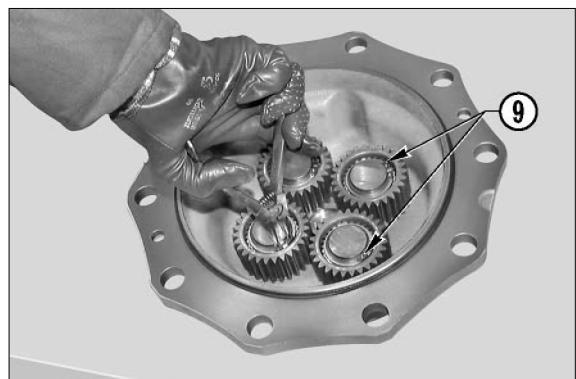

14W7FA068

(13) With the help of a puller, remove the planet wheel gears(10).

**NOTE**

Note down the assembly side of planet wheels.

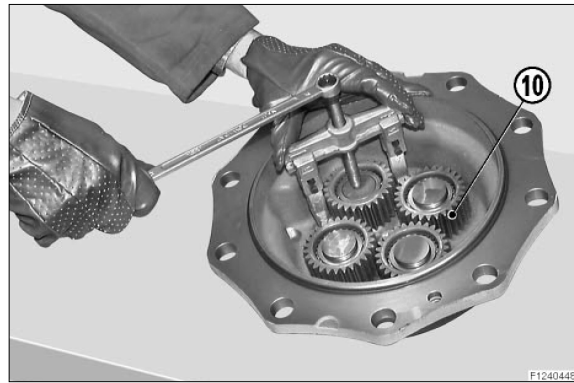

(14) Remove the snap ring(12) from the crown(13).

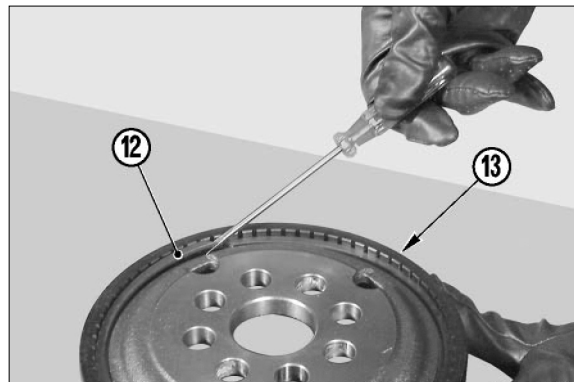

(15) Remove the crown flange(5).

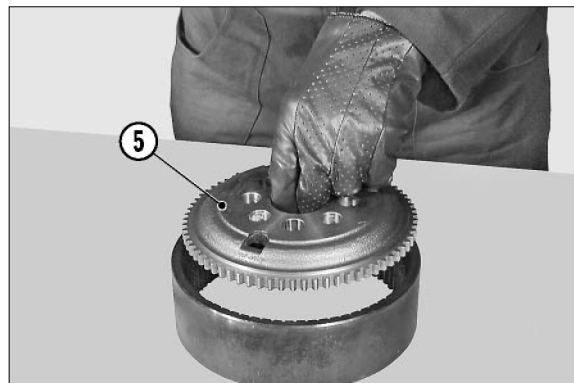

(16) Remove the sealing ring from the hub(14).



(17) Remove the internal bearing(15).



14W7FA073

(18) Remove the external thrust blocks from the bearings(8) and (15) forcing a pin-driver into the appropriate slots on the hub(7).

**NOTE**

Hammer in an alternate way so as to avoid crawling or deformation of the thrust blocks.

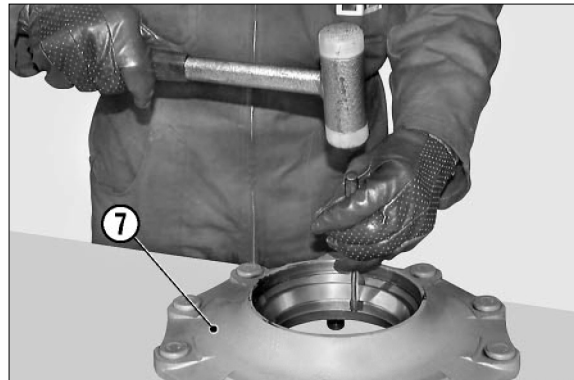

14W7FA074

(19) Use a puller to remove the centring ring(16), the sealing ring(17) and the bearing(18) from the steering case(3).

**NOTE**

Note down the orientation of both centring ring(16) and sealing ring(17).

**Front axle only.**

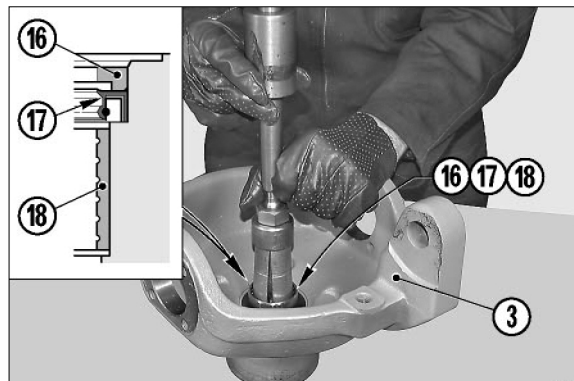

14W7FA075

## 2) ASSEMBLING THE PLANETARY REDUCTION

- (1) Lubricate the bushing(18) and the seat of the steering case(3).

Install the bushing(18), using tool T7.

**Front axle only.**

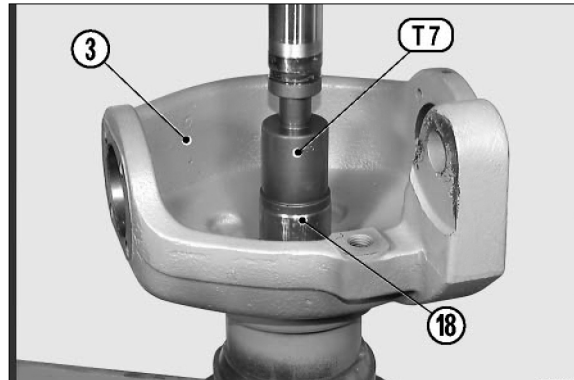

14W7FA077

- (2) Lubricate the outer surface of the sealing ring(17) and centring ring(16); fit them into their seat using tool T8.

**Front axle only.**

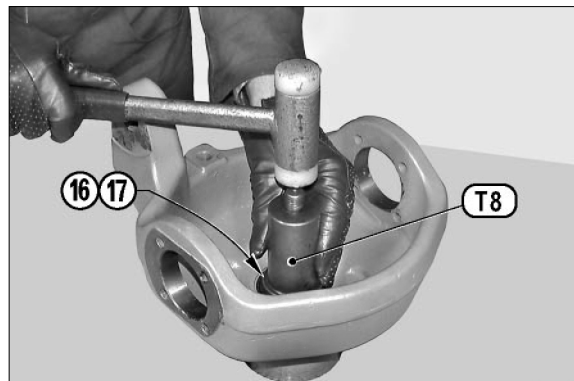

14W7FA078

- (3) Position the lower part of tool T9A and the thrust block of the external bearing(8) under the press.

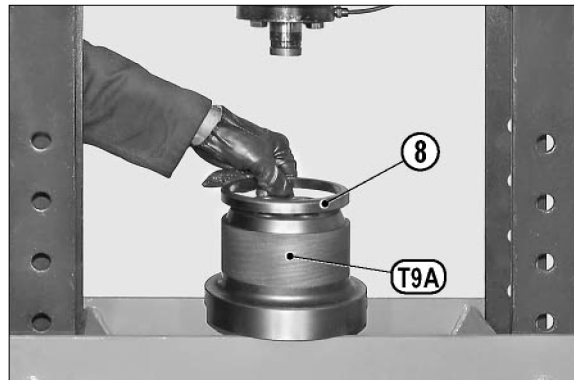

14W7FA079

- (4) Lubricate the seats of the bearings and position the hub(7) on tool T9A; position the thrust block of the internal bearing(15).

### **NOTE**

Check that the thrust block is correctly oriented.

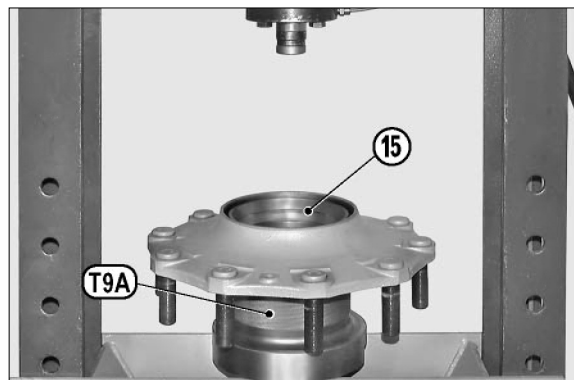

14W7FA080

- (5) Position the upper part of tool T9B and press the thrust blocks into the hub(7) all the way down.

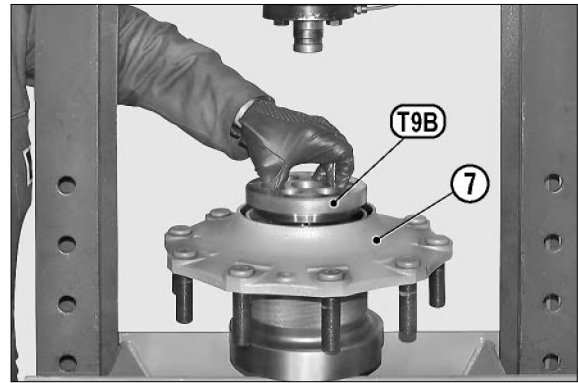

14W7FA081

- (6) Fit the bearing(15) into the internal thrust block.

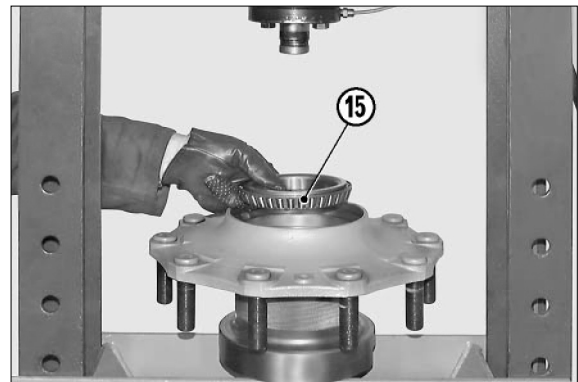

14W7FA082

- (7) Apply a repositionable jointing compound for seals to the outer surface of the sealing ring(14). Position the sealing ring(14) in the hub(7).

**NOTE**

Check that the ring(14) is correctly oriented.

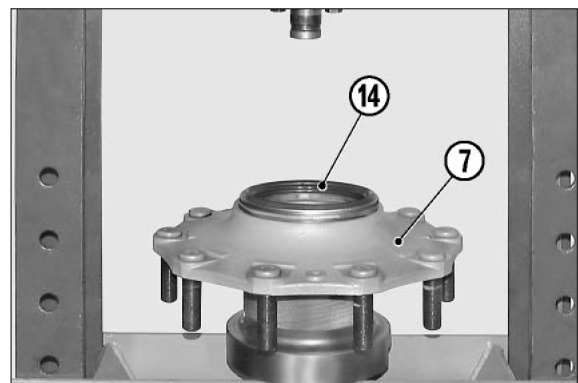

14W7FA083

- (8) Position tool T10 and press the sealing ring(14) into its seat.

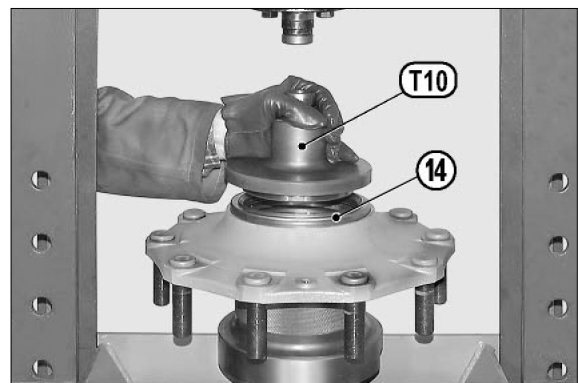

14W7FA084

(9) Insert the flange(5) in the crown(13).

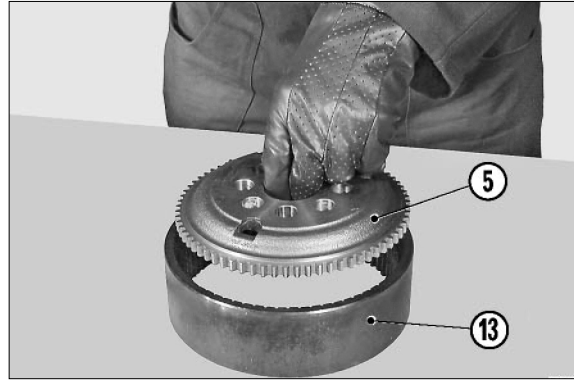

14W7FA085

(10) Insert the snap ring(12) in order to fix the flange(5) in the crown(13).

**NOTE**

Carefully check that ring(12) is properly inserted in the slot of the crown(13).

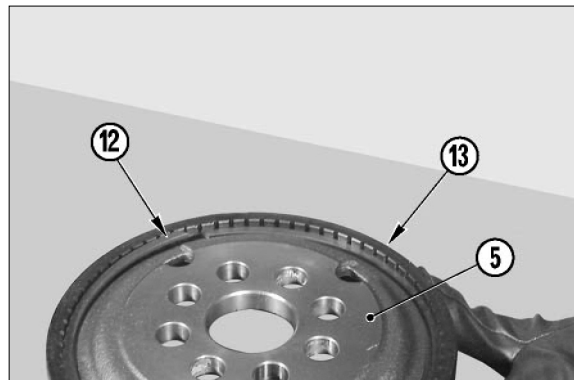

14W7FA086

(11) With the help of tool T11, insert the planet wheel gears(10) into the cover(2).  
Accurately check the orientation.

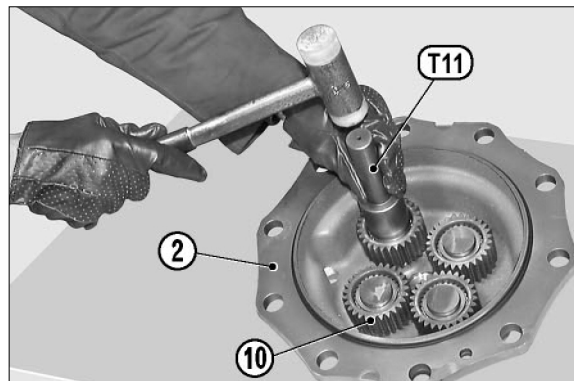

14W7FA087

(12) Lock the gears(10) into position by fitting the snap rings(9).

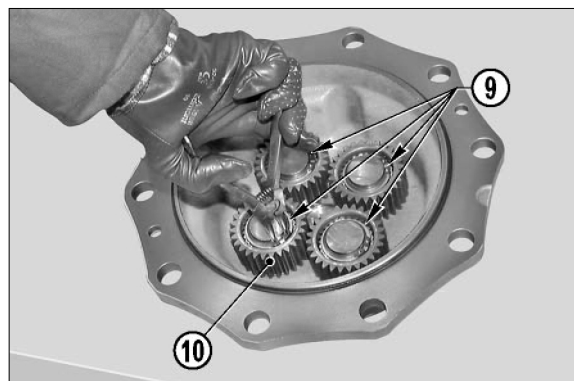

14W7FA088

- (13) Fit the steering case(3) onto the u-joint(19) and install the articulation pins. For pin assembly details, see “ HOW TO ASSEMBLE THE COMPLETE STEERING CASE ”.

**Front axle only.**

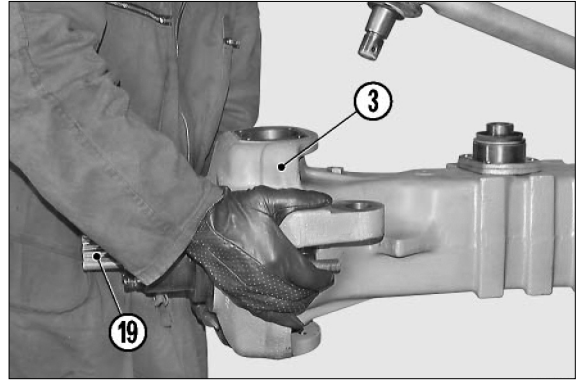

14W7FA089

- (14) Lubricate the outer face of the sealing ring(10) and with the help of tool T34, fit in the arm.

**NOTE**

Accurately check direction of assembly.

**Rear axle only.**

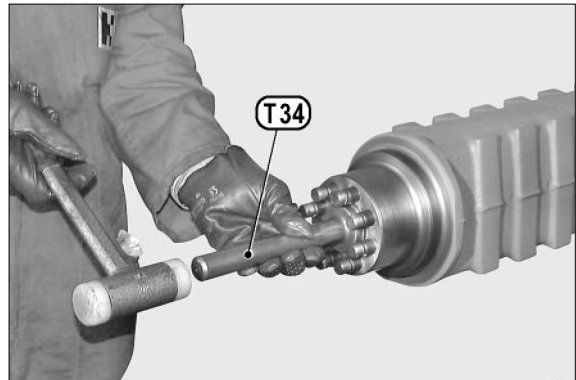

14W7RA051

- (15) Connect the steering bars.

For details, see “ HOW TO INSTALL THE COMPLETE STEERING CASE ”

**Front axle only.**

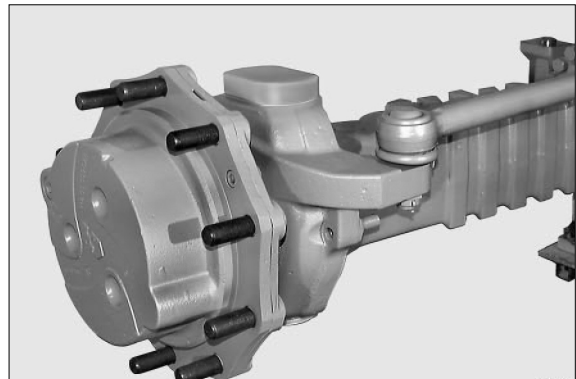

14W7FA090

- (16) Install the hub(7).

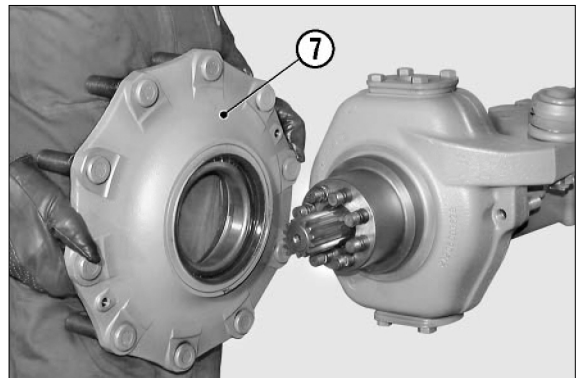

14W7FA091

(17) Install the external bearing(8).

**NOTE**

Using a plastic hammer, drive the bearing to the limit stop by lightly hammering around the edge.

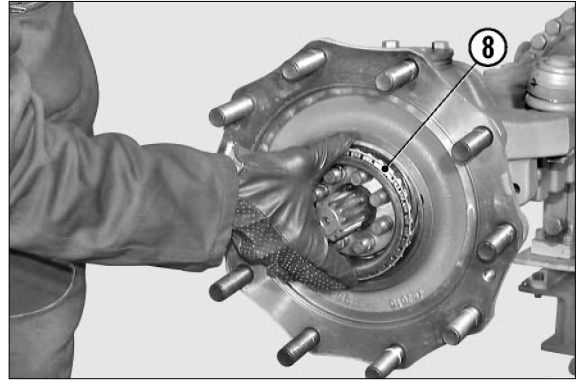

14W7FA092

(18) Fit the complete crown flange(5).

**NOTE**

In order to fasten the flange(5), use a plastic hammer and alternately hammer on several equidistant points.

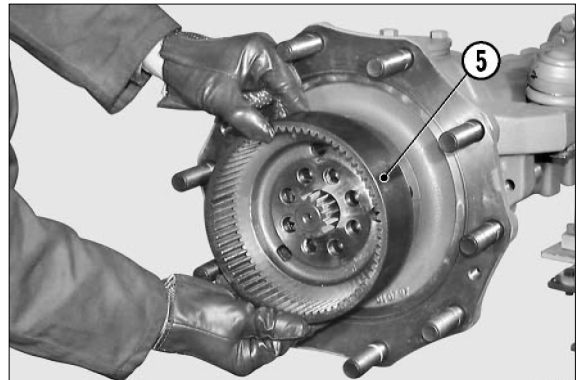

14W7FA093

(19) Apply tec nolube seal 101 grease to the surface of the safety flange(6) which touches the crown flange(5).  
Fit the safety flange(6).

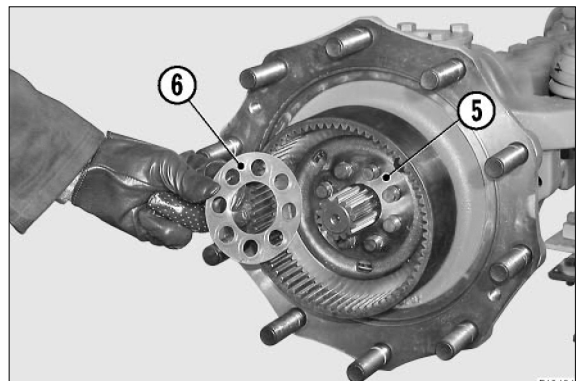

14W7FA094

(20) Apply loctite 242 to the studs and fit in the nuts(4).



14W7FA095

(21) Cross tighten the nuts(4) in two stages.

- Initial torque wrench setting : 12kgf · m  
(87lbf · ft)
- Final torque wrench setting :  
25.5~28.5kgf · m(185~206lbf · ft)

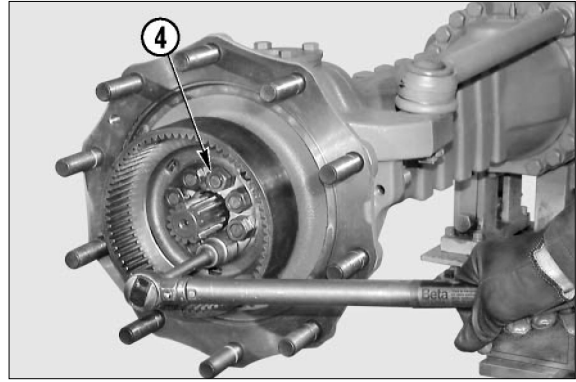

14W7FA096

(22) Fit the planetary carrier cover(2) onto the hub(3).

**Check that the O-ring(20) is in good condition and in position.**

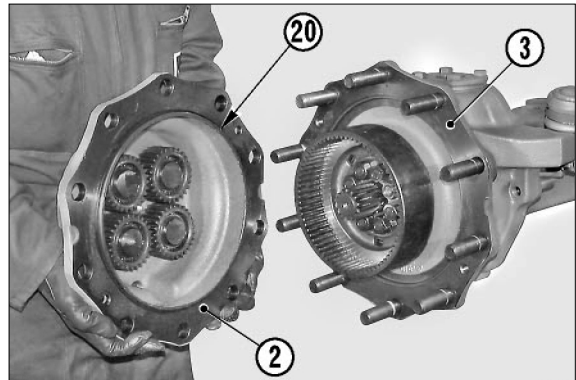

14W7FA097

(23) Lock the planetary carrier cover(2) by tightening the screws(1).

- Torque wrench setting for screws :  
4~5kgf · m(29~36lbf · ft)

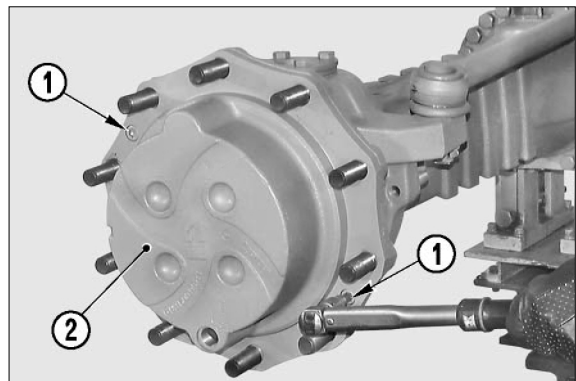

14W7FA098

## 8. THE STEERING CYLINDER

### FRONT AXLE ONLY

#### 1) HOW TO REMOVE THE STEERING CYLINDER

- (1) Remove the centring sensor(1) of the steering piston(2), if supplied.

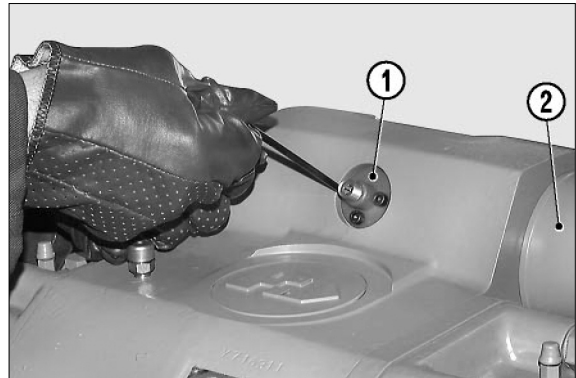

14W7FA099

- (2) Remove the safety cotter pins(3) from the articulation pins(4) of the steering bars(5).  
**Dispose of used cotter pins.**

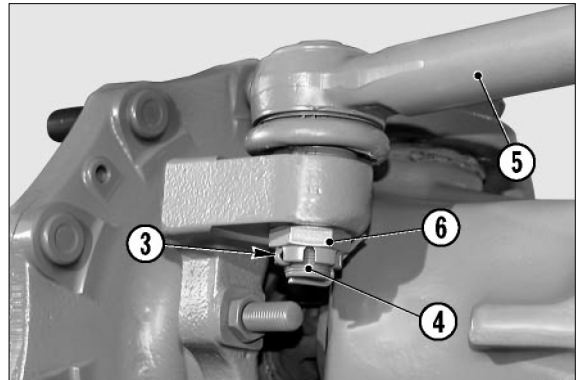

14W7FA100

- (3) Remove the castellated nuts(6) that lock the articulation pins(4).

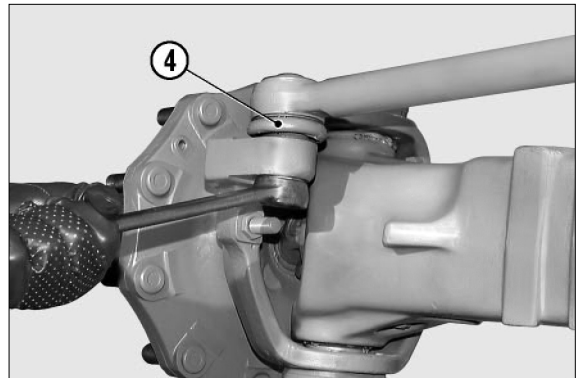

14W7FA101

- (4) Disconnect the tapered pins of the articulation (4) from the steering case(7) by means of a puller.

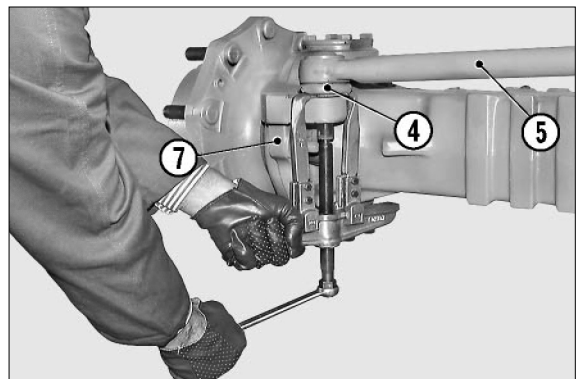

14W7FA102

- (5) If the connection of the steering bars includes a safety collar(13), raise the border.

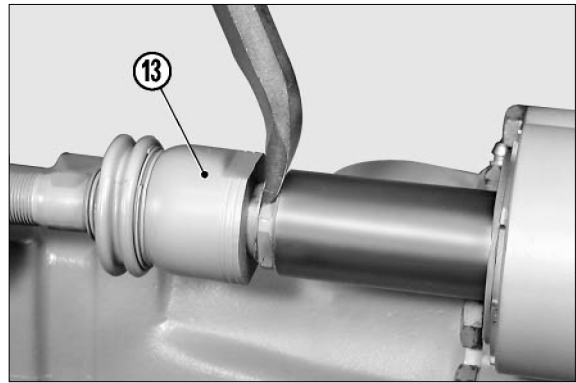

14W7FA103

- (6) Disconnect left and right steering bars(5) from the piston(2).

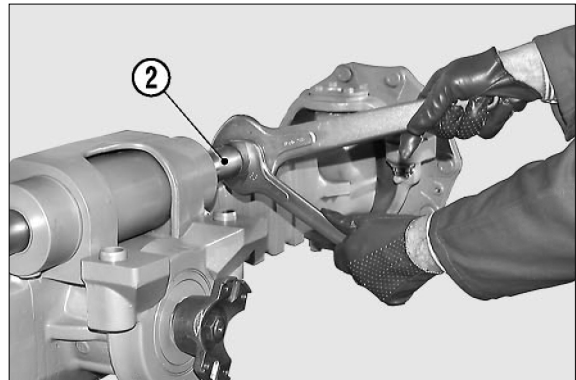

14W7FA104

- (7) Remove the securing screws(8) from the steering cylinder(9).

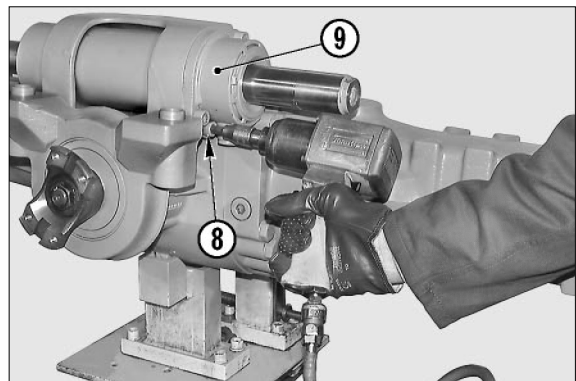

14W7FA105

- (8) Extract the cylinder(9) using a plastic hammer.

**NOTE**

For cylinder disassembly, refer to "HOW TO DISASSEMBLE THE STEERING CYLINDER".

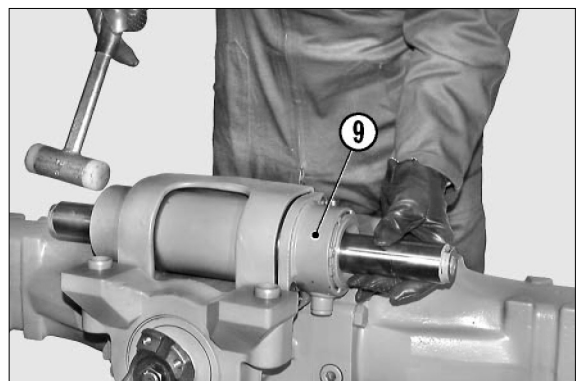

14W7FA106

## 2) HOW TO INSTALL THE STEERING CYLINDER

- (1) Check that the O-rings(15) of the axle unit are in good condition; lubricate the seats of the seals(15) and fit the steering cylinder(9) into its seat.

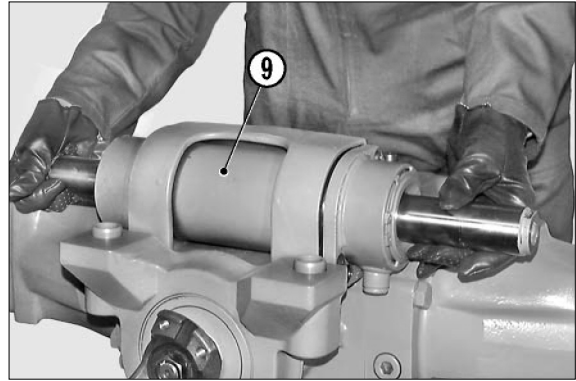

14W7FA108

- (2) Lock the cylinder by cross-tightening the screws(8).

- Torque wrench setting : 11~13kgf · m  
(80~94lbf · ft)

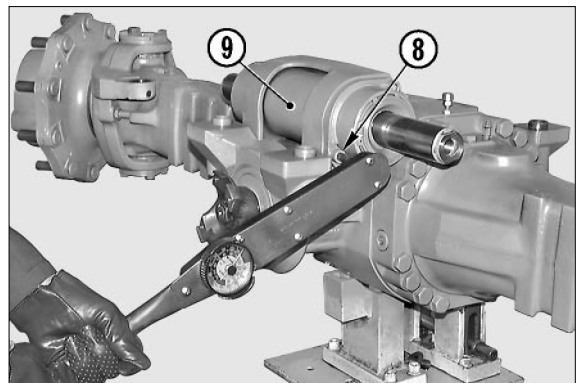

14W7FA109

- (3) Apply loctite 242 to the thread and connect the steering bars by screwing the terminals onto the piston stem.

- Torque wrench setting : 24~27kgf · m  
(174~195lbf · ft)

### NOTE

Versions with coupling require that the rim of the articulation(13) is riveted onto the surfaces of the piston stem.

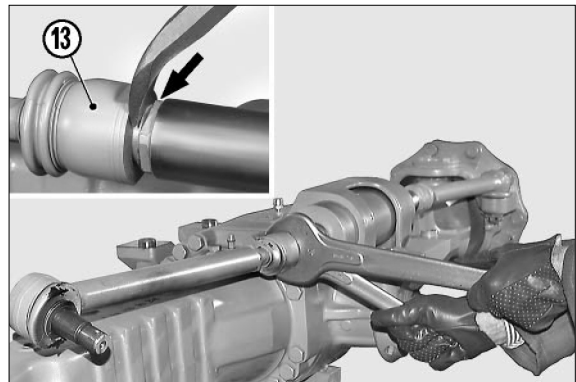

14W7FA110

- (4) Insert the pins(4) in the steering case(7) and lock into position using a torque wrench setting of 26~29kgf · m(188~210lbf · ft). Find the position of the notching in relation to the hole of the cotter pins and tighten the nut(6) further.

**Check that rubber guards(A) are intact.**

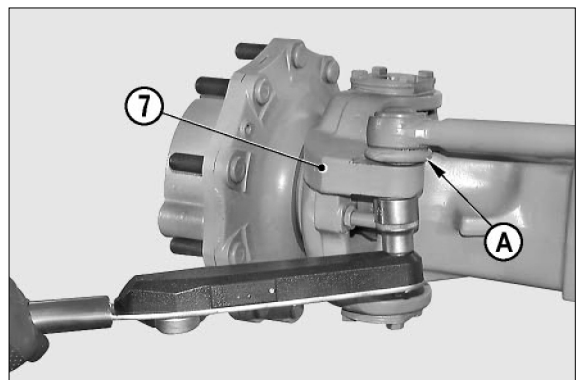

14W7FA111

- (5) Insert the cotter pins(3) and bend the safety stems.  
**Use new cotter pins.**

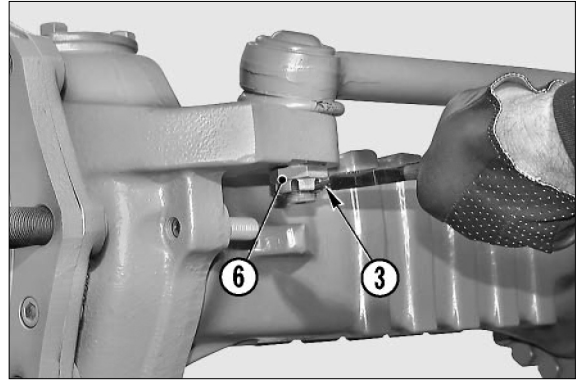

14W7FA112

- (6) Install the proximity(1) for checking piston contring-if applicable and tighten the screws(10).
- Torque wrench setting : 0.5~0.6kgf · m  
(3.6~4.3lbf · ft)

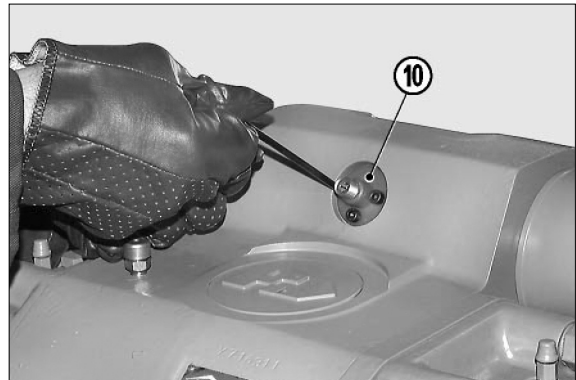

14W7FA113

- (7) Apply tools T12 to the hubs and lock them.  
Using a level " B " check that tools are perfectly flat and parallel to each other.  
**Eliminate the action of the negative brake, if fitted.**

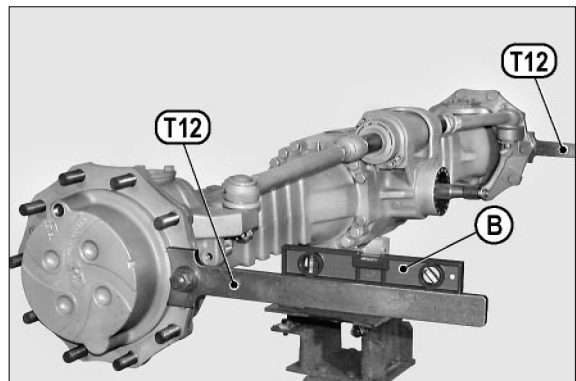

14W7FA114

- (8) Connect the sensor(1) to the inspection device according to either diagram.

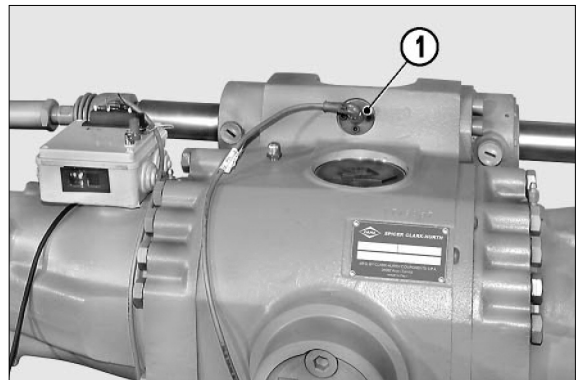

14W7FA115

(9) Sensor connection card, **STANDARD** version.

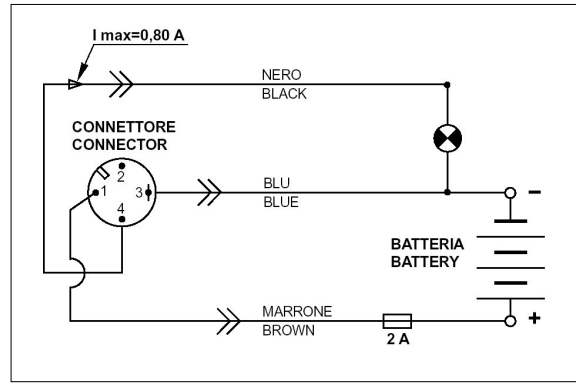

14W7FA116

(10) Sensor connection card, **OPTIONAL** version.

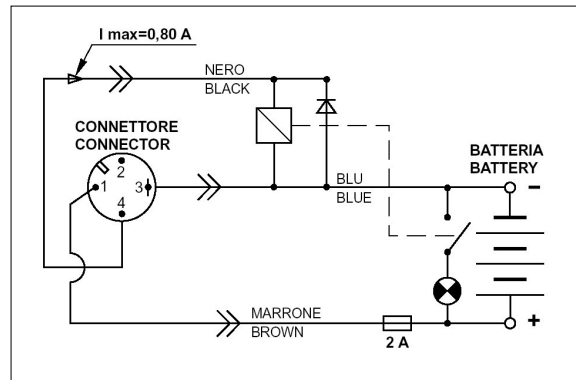

14W7FA117

(11) Centre the piston by slowly moving it first in one direction then in the other and position it half way on the stroke, which is determined by the switching on and off of the signal lamp of the inspection device in the reversal stage.

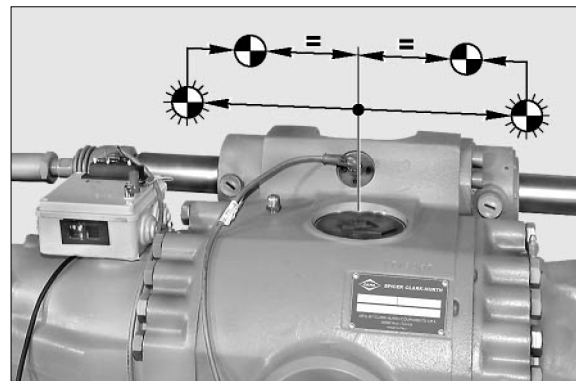

14W7FA118

(12) Inspect jut " C " on one side of the piston and note down the size for checking later adjustments.

**NOTE**

If cylinders come without a sensor, the centring of the piston must be carried out on the basis of the maximum stroke.

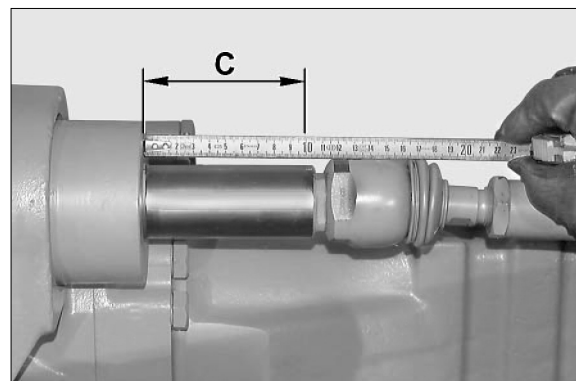

14W7FA119

- (13) Without moving the piston, check front and rear size at the edge of tools T12.  
Max. difference : 0.6~0.7mm.

**NOTE**

In order to check the rear size, rotate the bevel pinion and check that tools T12 are flat.

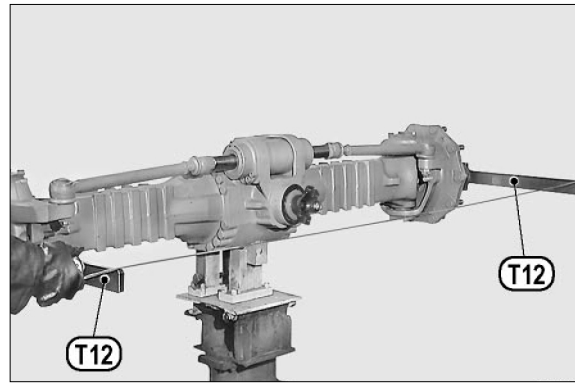

14W7FA120

- (14) If necessary, adjust convergency without moving the centring of the piston and adjust the length of the steering bars(5) or (14).

**NOTE**

With a half turn of screw, the front size is reduced by about 3mm, whereas the rear one is increased by about 3mm.

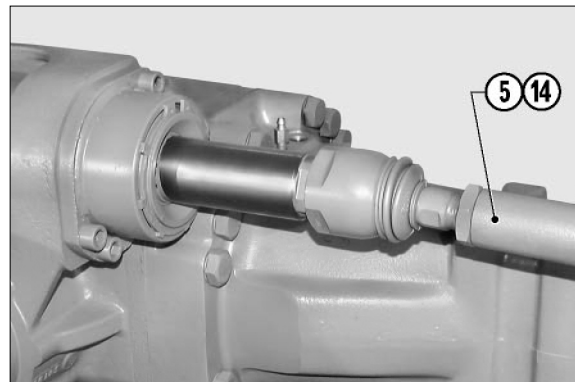

14W7FA121

- (15) Convergency adjustment on units with collar.  
Unloose the nuts on the collars(12).

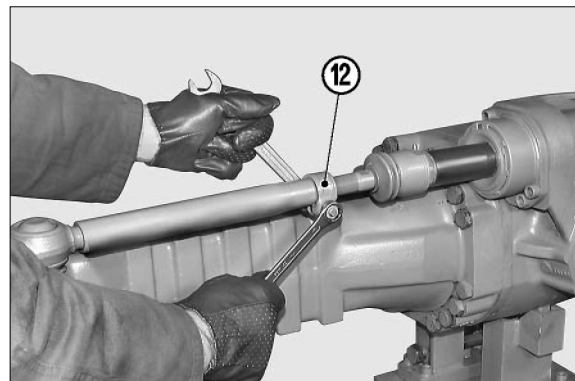

14W7FA122

- (16) Rotate the ball-and-socket joints(16) until convergency has been obtained.  
Check that articulations move easily and lock the collars(12).

- Torque wrench setting for nuts :  
4.2~5.2kgf · m(30~38lbf · ft)

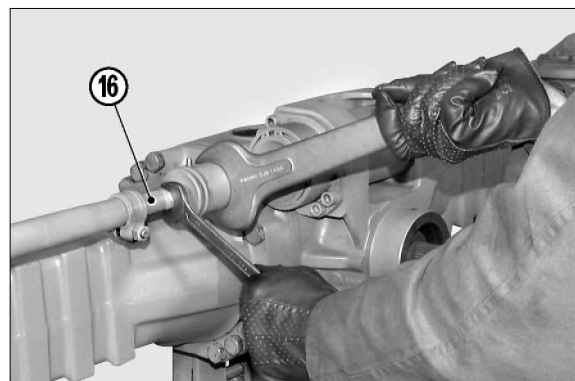

14W7FA123

(17) Convergency adjustment on alternative versions.

Unloose the nuts(11) and screw them onto the ball-and-socket joints(15).

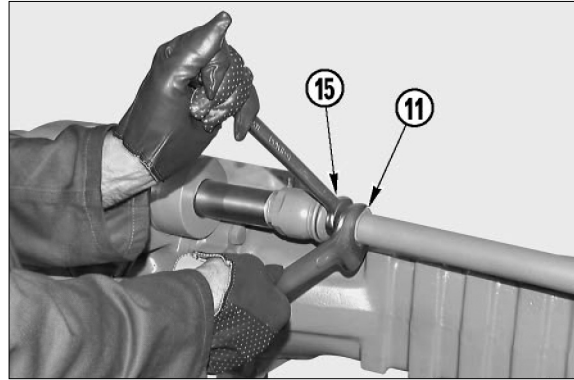

14W7FA124

(18) Hold the articulations still and rotate the ball-and-socket joints(15).

Once the convergency has been adjusted, lock the nuts(11).

- Torque wrench setting for nuts :  
30~33kgf · m(216~240lbf · ft)

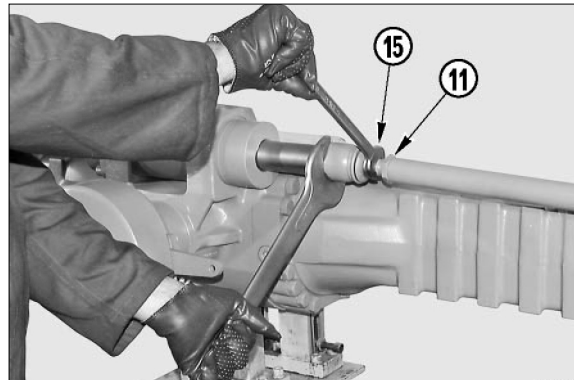

14W7FA125

(19) ADJUSTING THE STEERING ANGLE

Loosen the nut of the of the adjusting screws on cylinder side.

**NOTE**

Perform the same operations on both sides (see diagram).

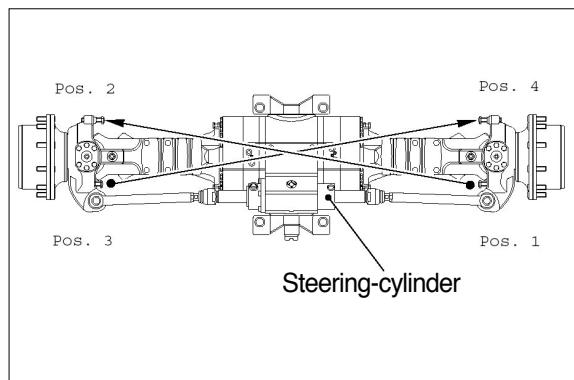

14W7FA126

(20) Perform one full steering operation until the adjusted screw leans against the arm stop.

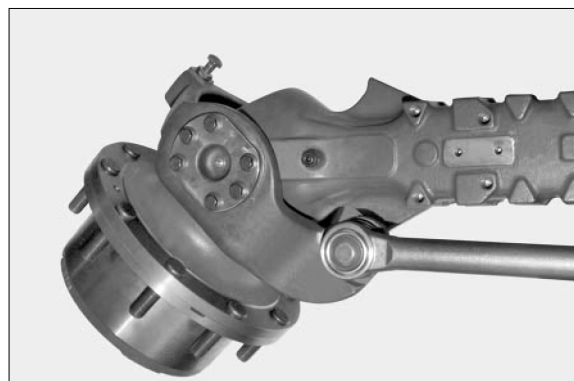

14W7FA127

(21) Perform one full steering operation until the adjusted screw leans against the arm stop.



14W7FA128

(22) As you hold the adjusted screw in position against the arm stop, adjust the screw opposite, on non-cylinder side, until it leans against the arm stop.

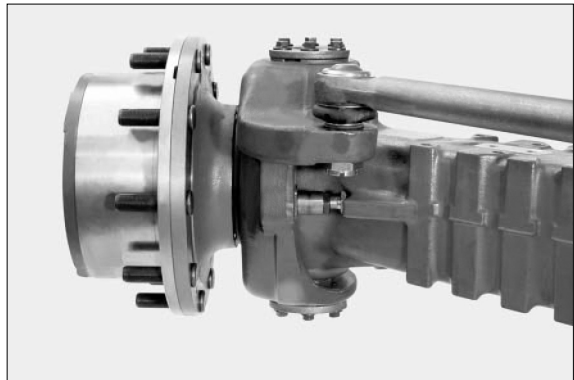

14W7FA129

(23) **IMPORTANT**

The screws must lean against the respective arm stops all at the same time.

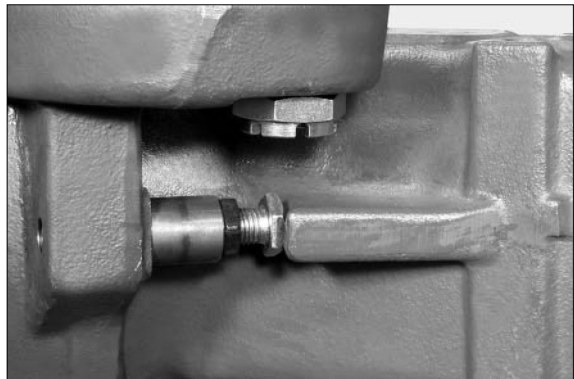

14W7FA130

Steering angle	Distance(mm)
40°	30
37°	37
36°	39.4
35°	41.8
30°	53.3
29°	38.2

### 3) HOW TO DISASSEMBLE THE STEERING CYLINDER

- (1) Remove the snap ring(1) from the cylinder head(2).

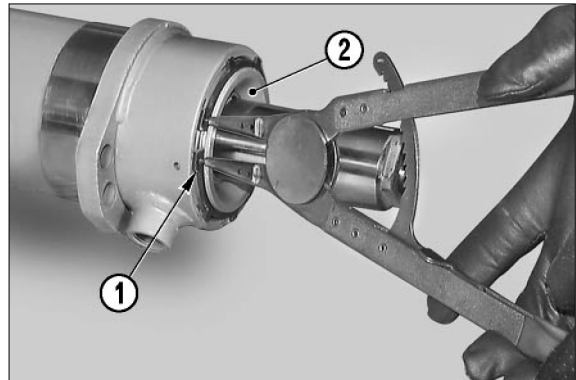

14W7FA131

- (2) With the help of a plastic hammer, push the head(2) inside the cylinder(3).

**NOTE**

The head should line up with the edge of the cylinder.

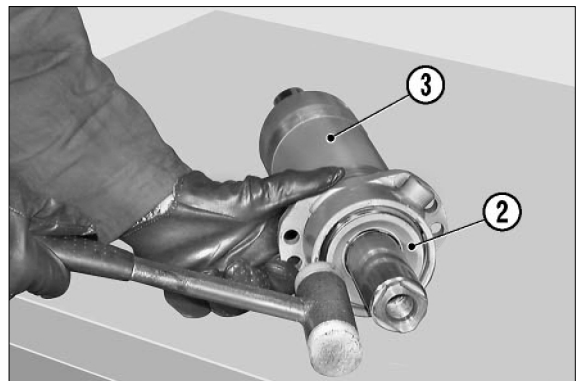

14W7FA132

- (3) With the help of a drift, apply pressure to the stop ring(4) that is placed inside the cylinder(3) and extract the ring using a screwdriver.

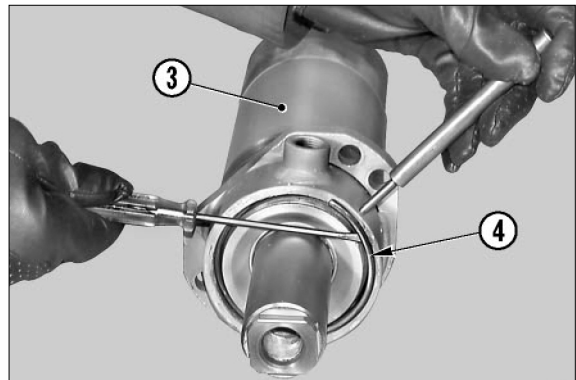

14W7FA133

- (4) Hammer the piston(5) on the rear of the head(2) using a plastic hammer. Continue hammering until the head(2) is ejected from the cylinder(3).

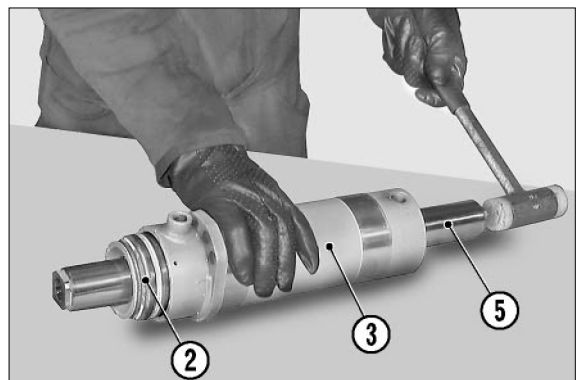

14W7FA134

- (5) Disassemble the cylinder unit(3) by extracting first the head(2), then the piston(5).

**Note down the assembly side of the piston(5). The bevelled part " A " of the piston is oriented towards the head(2).**

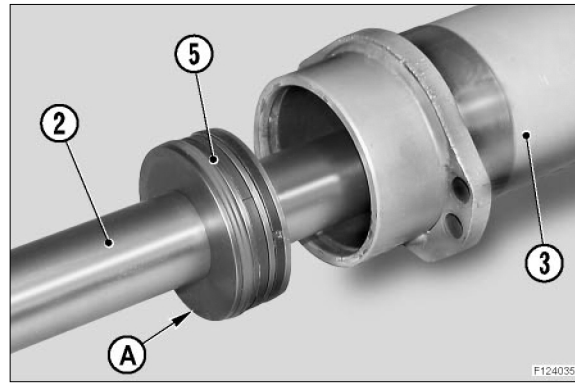

14W7FA135

- (6) Remove all seals, anti-extrusion rings and scraper rings from head(2), cylinder(3) and piston(5).

**NOTE**

All seals must be replaced every time the unit is disassembled.

Particular attention must be paid not to damage the seats of both seals and piston side.

#### 4) HOW TO ASSEMBLE THE STEERING CYLINDER

- (1) After applying grease, install the sealing ring(6) of the shaft, the anti-extrusion ring(7) and the scraper ring(8) inside the cylinder(3).

**Thoroughly check that positioning of the anti-extrusion ring(7) is correct.**

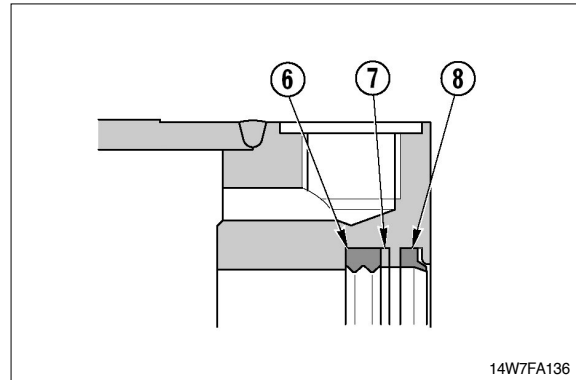

- (2) After applying grease, install the sealing ring(6) of the shaft, the anti-extrusion ring(7) and the scraper ring(8) in the head(2).

**Thoroughly check that positioning of the anti-extrusion(7) ring is correct.**

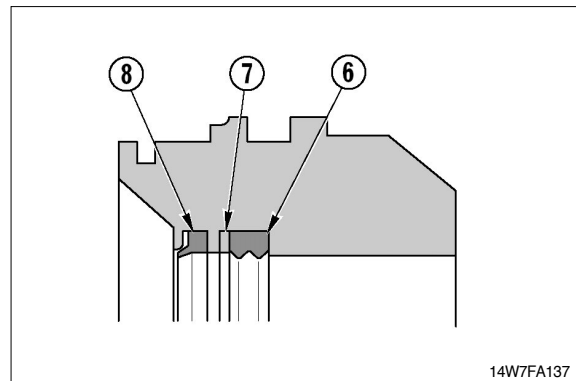

- (3) Fit the seal(9) onto the outside of the head(2).

**In order to facilitate assembly, apply grease to the outer surface of the piston.**

**Do not roll the seal(9) up.**

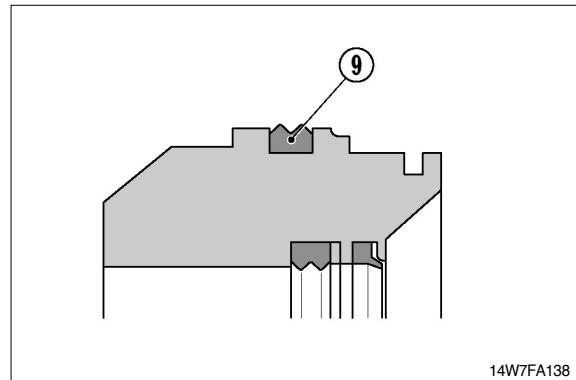

- (4) Prepare the piston(5) fitting it with the guide ring(10), the magnetic ring(11), the O-ring(12) and the seal(13).

**In order to facilitate assembly, apply grease.**

**If a centering sensor is not fitted, then the magnetic ring(11) should be replaced by another guide ring(10).**

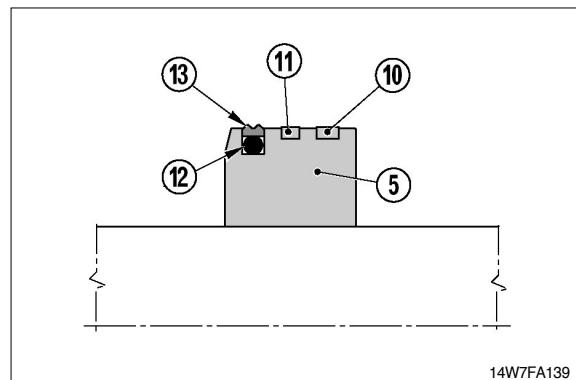

- (5) Apply tool T18 to the shaft on the opposite side of the head(2) and centre it on the cylinder(3) so that it fits into the piston(5).

**NOTE**

Apply a little grease to seals and cylinder.

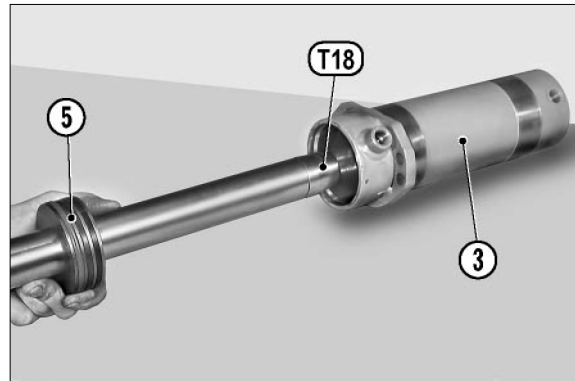

14W7FA140

- (6) Push the piston(5) into the cylinder for 100mm using a plastic hammer.

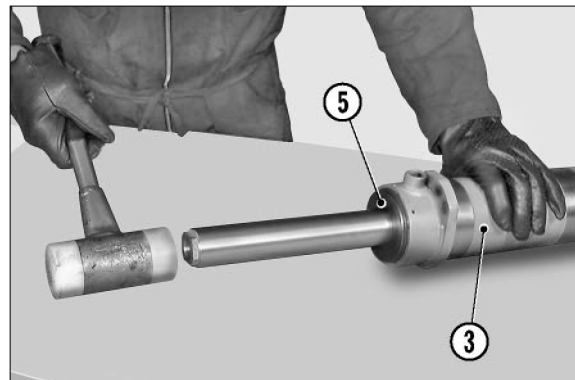

14W7FA141

- (7) Remove tool T18 and apply it to the opposite side of the piston(5).

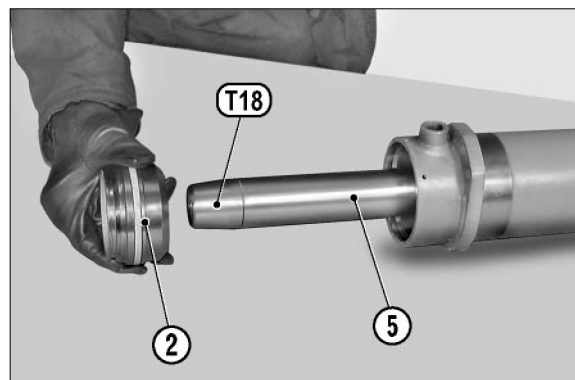

14W7FA142

- (8) Apply grease to head(2) seals, fit the head onto the piston and push it into the cylinder(3) using a plastic hammer.

**NOTE**

Insert the head as to line it up with the edge of the cylinder.

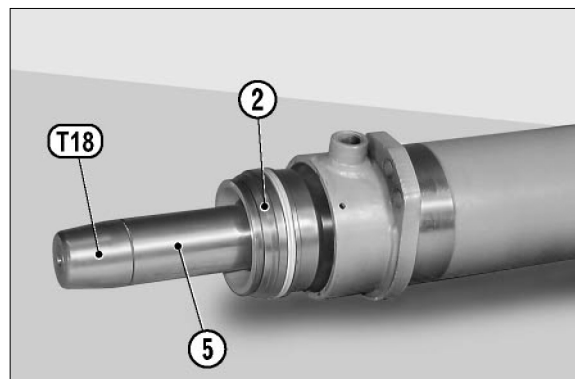

14W7FA143

- (9) Insert the stop ring(4) ensuring that it fits into the seat of the cylinder(3).

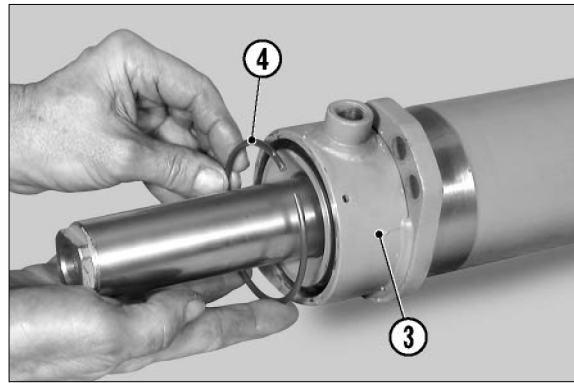

14W7FA144

- (10) Apply pressure to the head using two screwdrivers or levers until the head is fastened onto the stop ring(4).

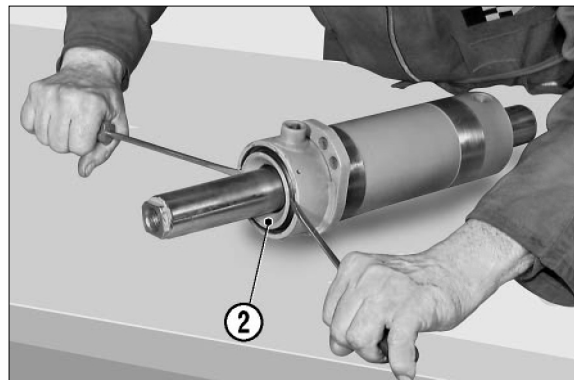

14W7FA145

- (11) Fit the snap ring(1) on the head(2).  
**Make sure that the snap ring(1) is securely fastened in its seat.**  
**If necessary, force it into its seat using a drift and a hammer.**

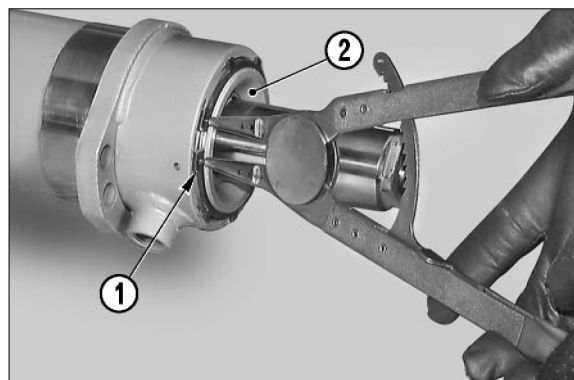

14W7FA146

## 9. THE DIFFERENTIAL UNIT

### 1) HOW TO REMOVE THE DIFFERENTIAL UNIT

- (1) Remove the complete arms.  
For details, see " CHECKING WEAR AND REPLACING THE BRAKING DISKS ".

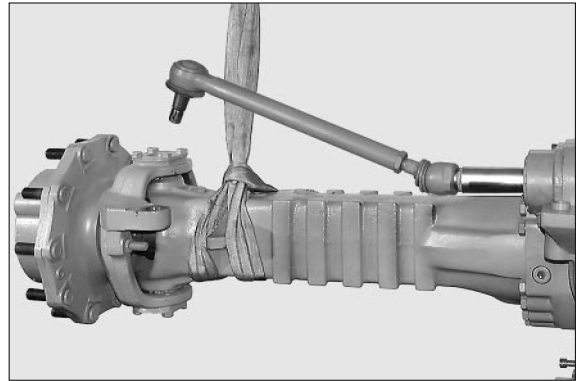

14W7RA109

- (2) Mark the position of the ring nuts(1).  
Remove the fitting screws(3) from the ring nuts(1).

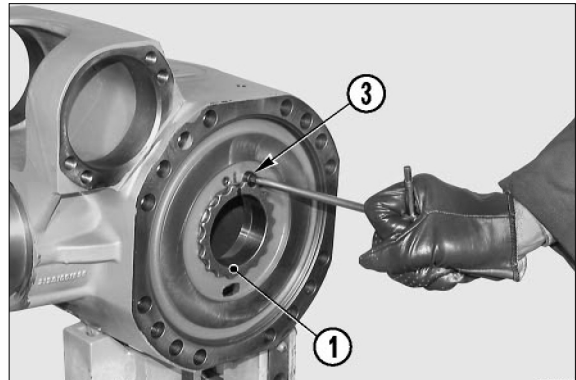

14W7RA110

- (3) Uniformly heat the ring nuts(1) up to a temperature of 80°C.

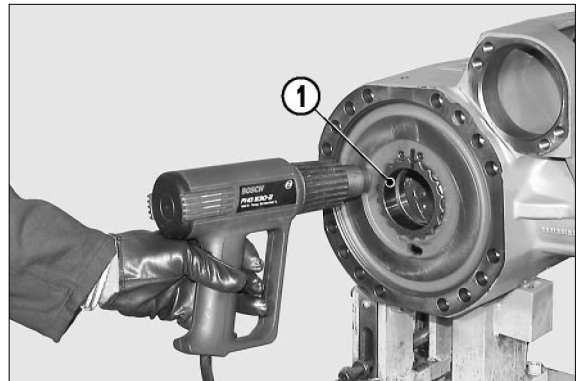

14W7RA111

- (4) Apply tool T13 and remove the ring nuts.  
**NOTE**  
Accurately clean the threaded portions on ring nuts of body and cover.

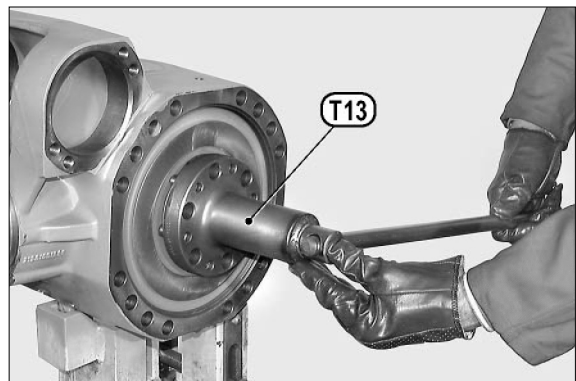

14W7RA112

- (5) Remove the fitting screws(4) from the middle cover(5).

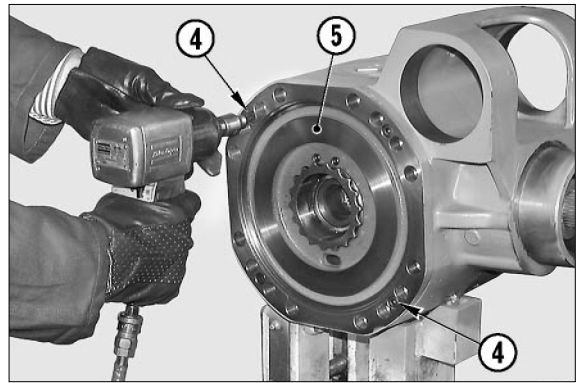

14W7RA113

- (6) Insert a screw-driver in the opposing slots then force and remove the middle cover(5) and the complete differential unit(6).

**NOTE**

Support the pieces using a rod.

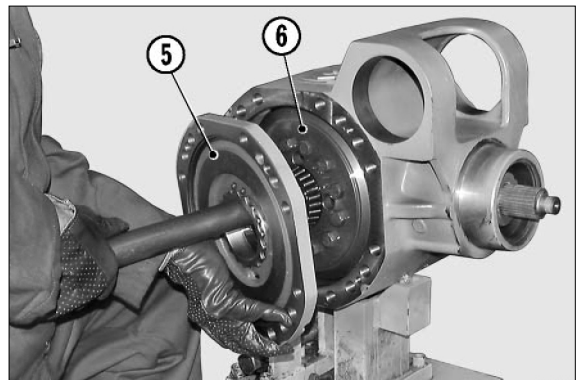

14W7RA114

- (7) If the bearings need replacing, extract the external thrust blocks of the bearings(7) and (8) from middle cover(5) and central body(2).

**NOTE**

Accurately check the O-ring(9).

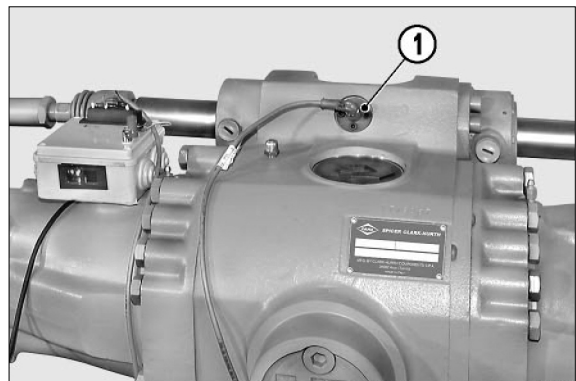

14W7RA115

- (8) Remove the top plug(10).

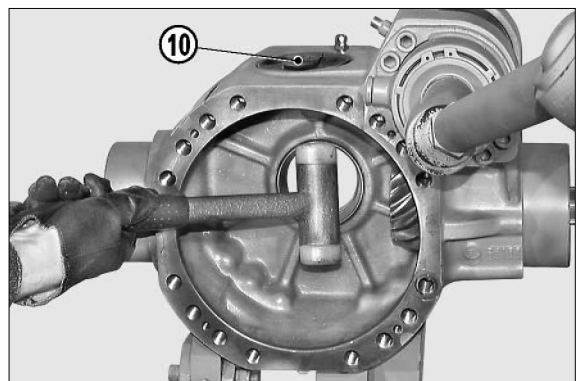

14W7RA116

## 2) HOW TO DISASSEMBLE THE DIFFERENTIAL UNIT

- (1) Remove the fitting screws(11) from the crown(12).

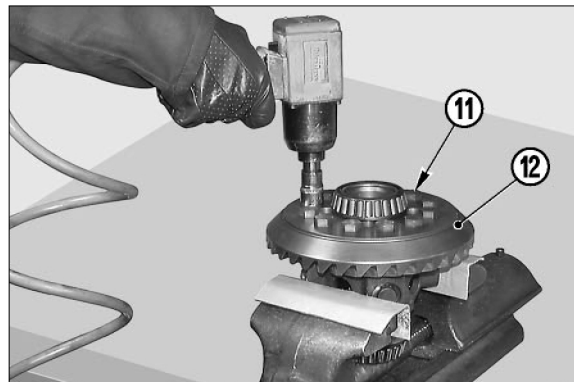

14W7RA117

- (2) If the bearing need replacing, extract the bearing(7) and remove the crown(12).

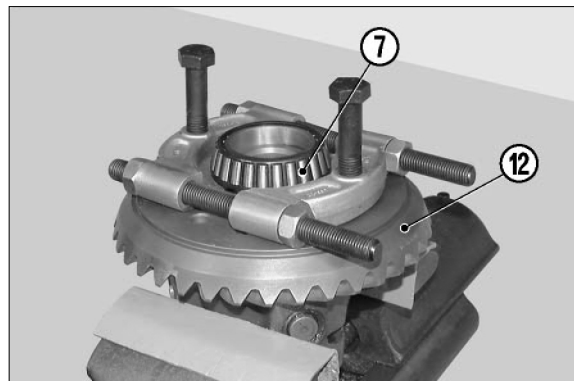

14W7RA118

- (3) Remove the shim washer(13) and the planetary gear(14).

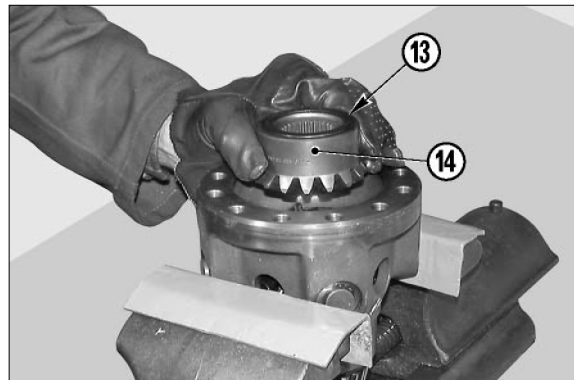

14W7RA119

- (4) If the bearing need replacing, extract the bearing(8) from the differential carrier(15).

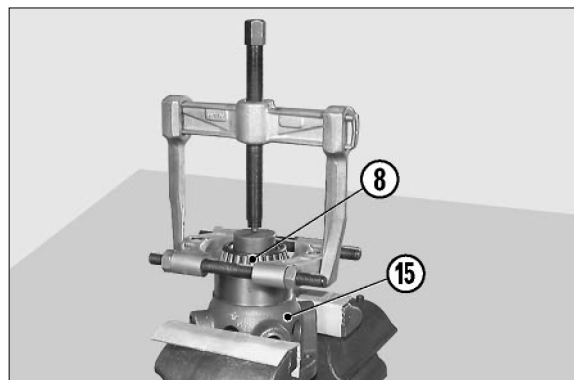

14W7RA120

- (5) Remove the snap rings(16) from the two pins(17) of the planet wheel gears(18).

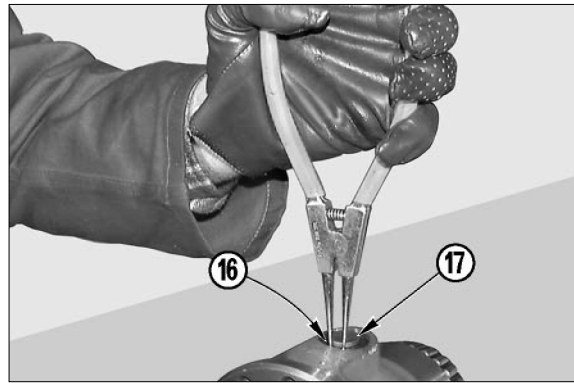

14W7RA121

- (6) Insert tool T14 between the planet wheel gears(18).

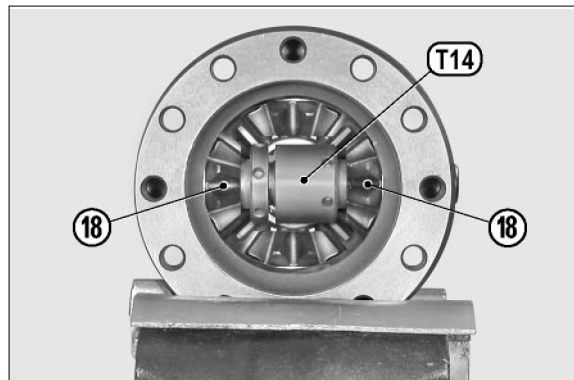

14W7RA135

- (7) Force tool T14 in-between the planet wheel gears(18) using two pin-drivers.  
**Make sure that tool T14 is perfectly lined up with the pins(17) when locked.**

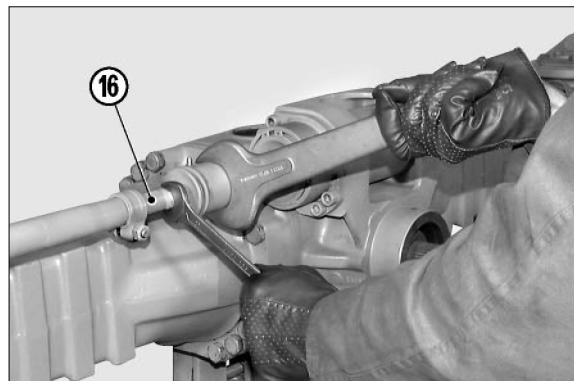

14W7RA123

- (8) Place the differential carrier(15) under a press, position bush T15 and insert gudgeon T16A. Press T16A pin to limit position.

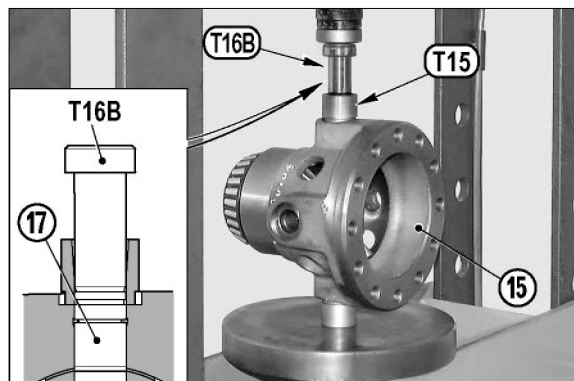

14W7RA124

(9) Remove gudgeon T16A and bush T15.

**NOTE**

In this condition the tool T14 contains pin(17).

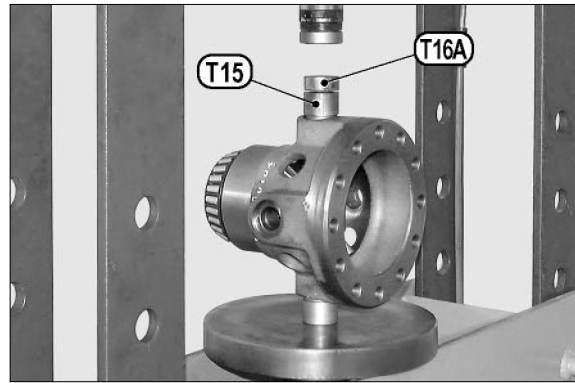

14W7RA125

(10) Remove tool T14 together with the pin(17) of the planet wheel.

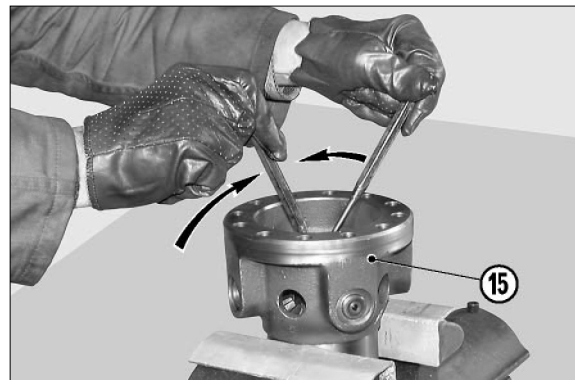

14W7RA126

(11) Leave the released planetary gear in position and again lock tool T14.  
Repeat the operations for the extraction of the pin of the 2<sup>nd</sup> planet wheel(17).  
Repeat the operations for all other pins.

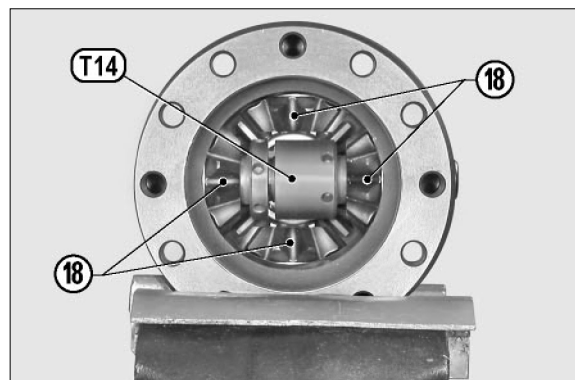

14W7RA127

(12) Remove tool T14 and remove the last two planet wheel gears(18), the 2<sup>nd</sup> differential unit gear(14) and the relative shim washer(13) from the differential carrier.



14W7RA128

### 3) HOW TO ASSEMBLE THE DIFFERENTIAL UNIT

- (1) Insert the shim washer(13) and the planetary gear(14) in the differential carrier(15).

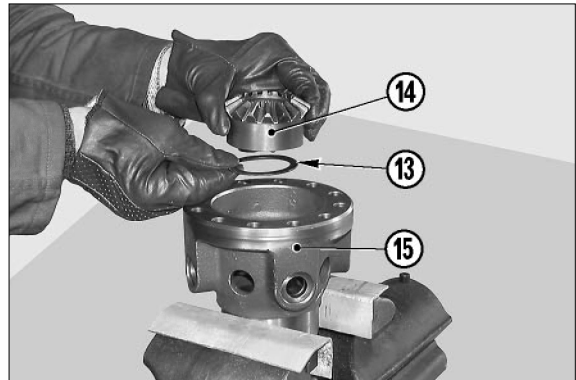

14W7RA128

- (2) Position the shim washer(19) and the first planet wheel gear(18). Hold them in position using bar T16C.

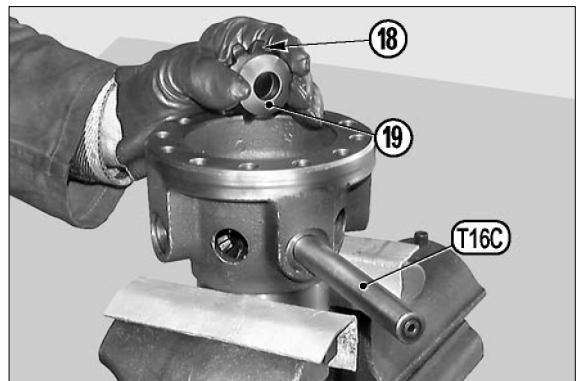

14W7RA132

- (3) With the help of gudgeon T16A, position the second planet wheel gear(18) and the relative shim washer(19).

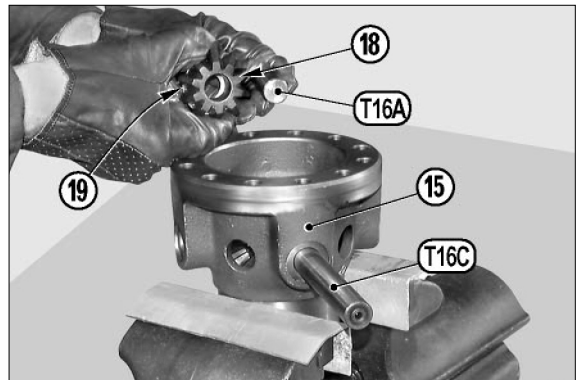

14W7RA133

- (4) Insert tool T14 between the two planetary gears(18). Line up the entire unit by pushing bar T16C all the way down until gudgeon T16A is ejected.

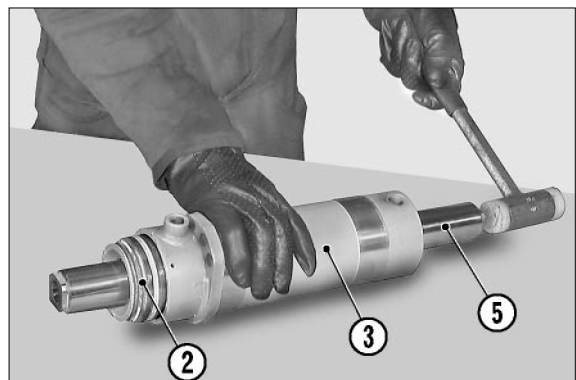

14W7RA134

- (5) Lock tool T14 behind the planet wheel gears(18).  
After locking, remove bar T16C.

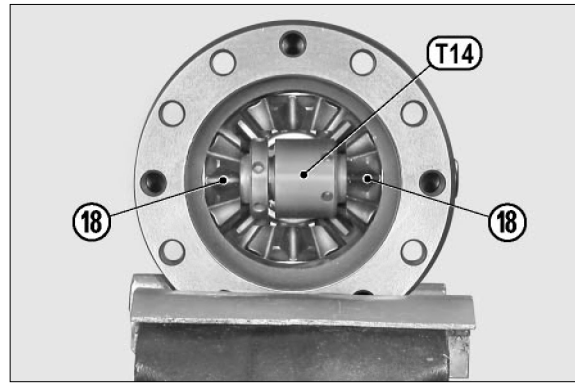

14W7RA135

- (6) Fit the snap rings(20) onto the pins(17).

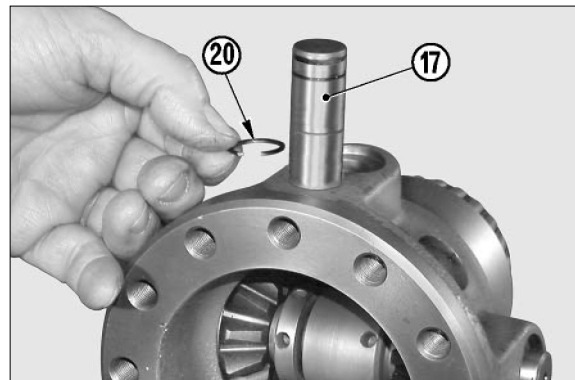

14W7RA136

- (7) Place the differential carrier(15) under the press, position bush T15 and insert the planet wheel pin(17).

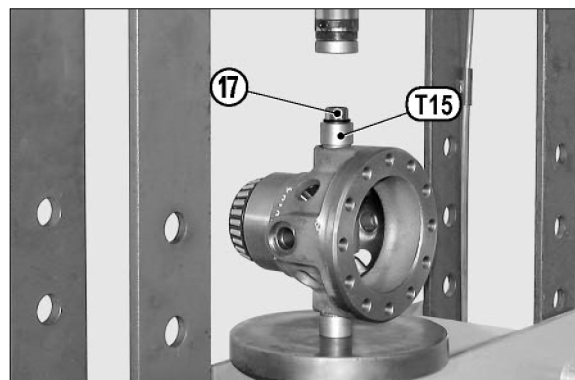

14W7RA137

- (8) Put gudgeon T16B on top of the planet wheel pin(17).

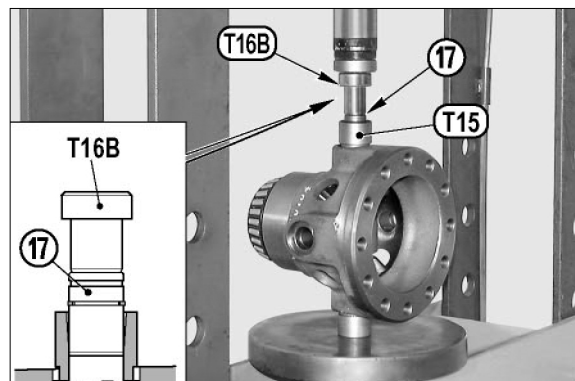

14W7RA138

(9) Press T16B pin all the way down.

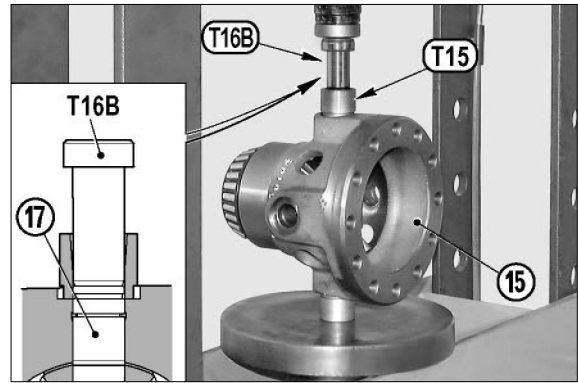

14W7RA139

(10) Remove gudgeon T16B, bush T15 and fit the snap ring(16) on the pin(17).

**Make sure that the snap ring centres the seat and that it rests on the surface of the differential carrier.**

**Repeat the operations on the other planet wheel pin or planet wheel axle.**

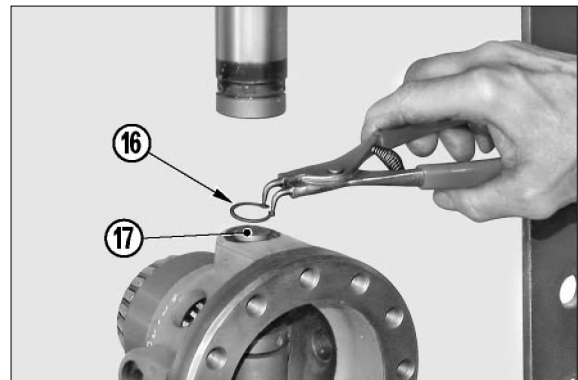

14W7RA140

(11) Position the second planetary gear(14) in the differential carrier(15).

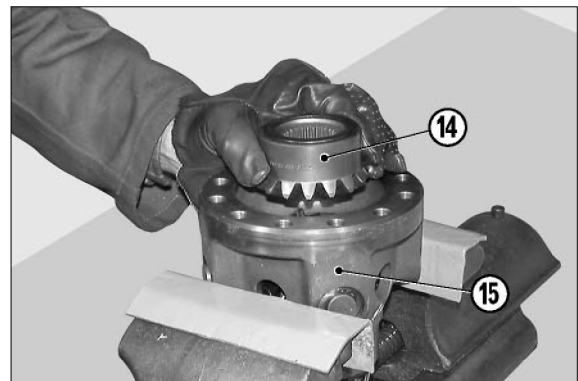

14W7RA141

(12) Position the shim washer(13) on the crown(12).

**NOTE**

In order to hold the shim washer(13) in position, apply grease to it.

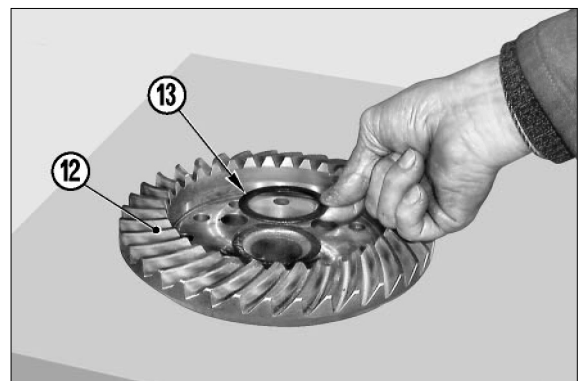

14W7RA142

(13) Position the crown(12) on the differential carrier(15) and lock it with screws(11) applied with loctite 242.

- Torque wrench setting for screws :  
13~14kgf · m(94~101lb · ft)

**NOTE**

Secure the screws using the cross-tightening method.

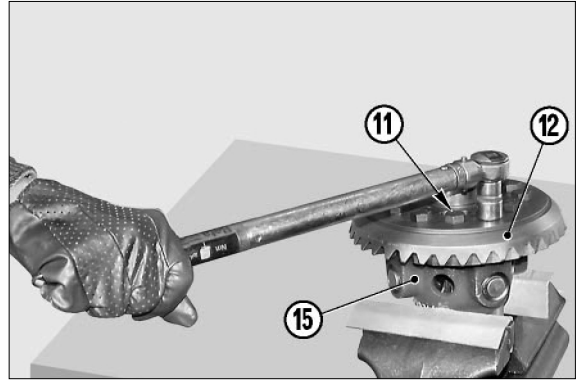

14W7RA143

(14) Install the bearings(7) and (8) using tool T17.

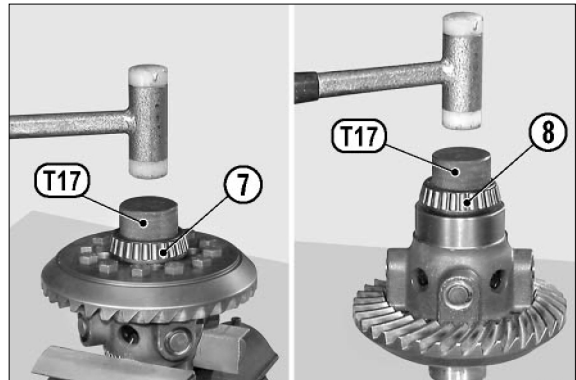

14W7RA144

(15) If the bearings are replaced, insert the external thrust blocks in the middle cover(5) and in the central body(2).

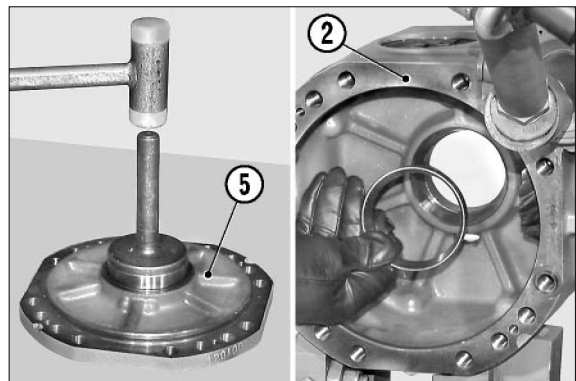

14W7RA145

#### 4) HOW TO INSTALL THE DIFFERENTIAL UNIT

- (1) Position the differential unit(6) in the central body(2) with the help of a bar and fit the middle cover(5).

**NOTE**

Thoroughly check the state of the O-ring(9) and make sure that the cover is fitted with the oil discharge in the lower position.

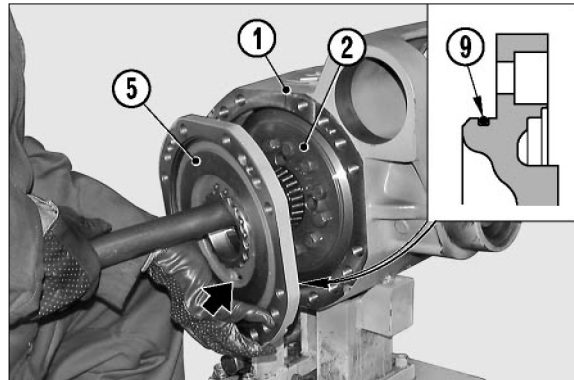

14W7RA146

- (2) Lock the middle cover(5) with screws(4).

- Torque wrench setting for screw :  
2.4~2.6kgf · m(17~19lb · ft)

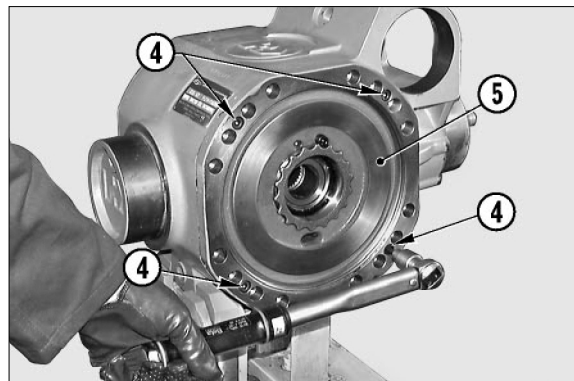

14W7RA147

- (3) Tighten ring nuts on the crown side until clearance between pinion and crown is zero, then lock the crown; go back 1/4-1/2 turn.

**NOTE**

If the ring nuts(1) are removed, spread them with loctite 242.

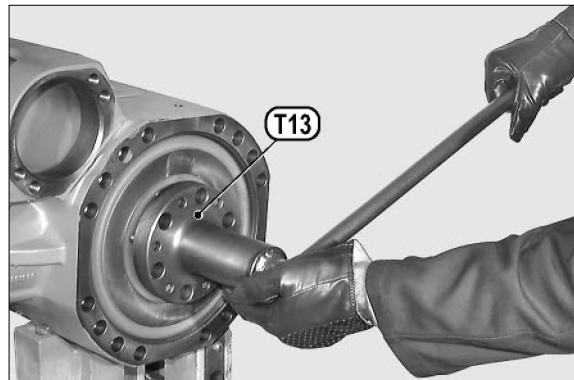

14W7RA148

- (4) Pre-set the bearings by means of the ring nut situated on the opposite side of the crown, so as to increase pinion torque up to 0.14~0.21kgf · m(1~1.5lb · ft).

**If bearings are not new, check the static torque; if bearings are new, check the continuous torque.**

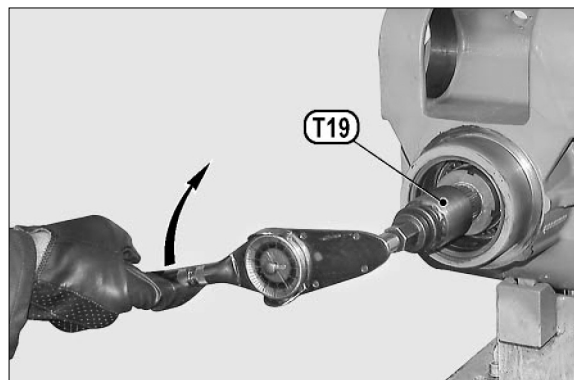

14W7RA149

- (5) Introduce a comparator with rotary key " A " through the top plug hole(10). Position the comparator on the centre of one of the teeth of the crown(12), pre-set it to 1mm and reset it.

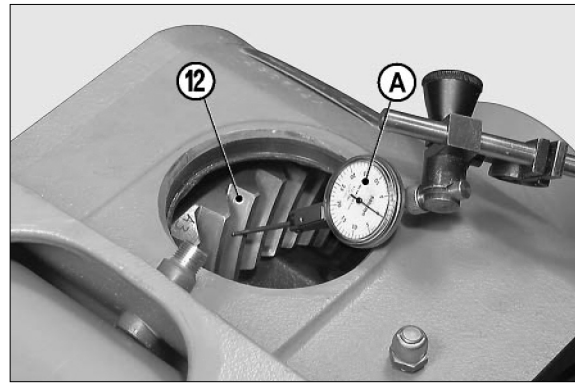

14W7RA150

- (6) Manually move the crown(12) in both directions in order to check the existing backlash between the pinion and the crown.

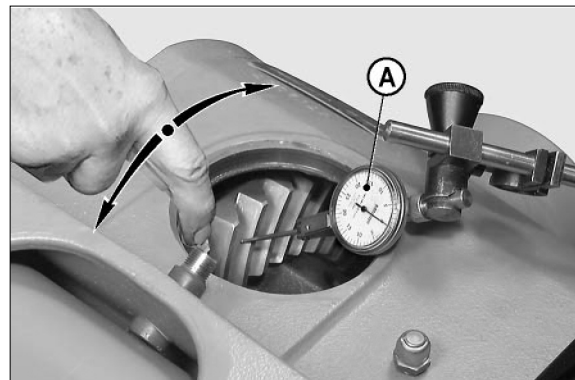

14W7RA151

- (7) Adjust the backlash between the pinion and the crown by unloosening one of the ring nuts(1) and tightening the opposite to compensate.  
Normal backlash : see table.

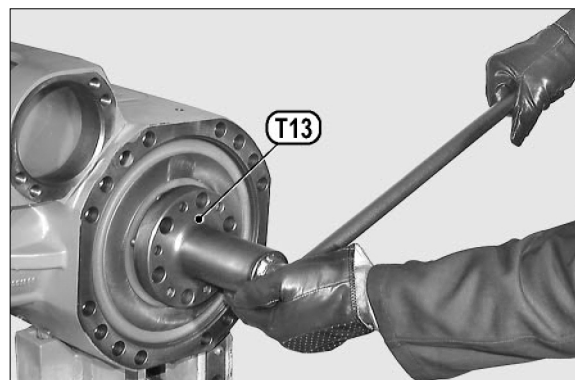

14W7RA152

- (8) Difference between MIN and MAX clearance for whole circumference should not exceed 0.09mm.

Ratio	Clearance	
	Min	Max
9 ÷ 34	0.18	0.23
9 ÷ 35	0.13	0.18
11 ÷ 31	0.20	0.28
11 ÷ 35	0.13	0.18
12 ÷ 35	0.13	0.18
12 ÷ 41	0.15	0.20
14 ÷ 32	0.18	0.23
14 ÷ 36	0.15	0.20
14 ÷ 41	0.15	0.20
15 ÷ 32	0.18	0.23
15 ÷ 47	0.13	0.18

(9) Apply loctite 242 to the screws(3), fit them into one of the two holes and tighten.

- Torque wrench setting : 2.4~2.6kgf · m  
(17~19lbf · ft)

Fit the top plug(10) after applying repositionable jointing compound for seals to the rims.

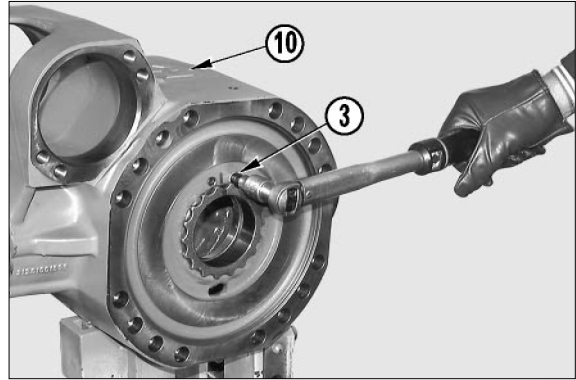

14W7RA152

(10) Re-install the complete arms.

For details, see " CHECKING WEAR AND REPLACING THE BRAKING DISKS " .

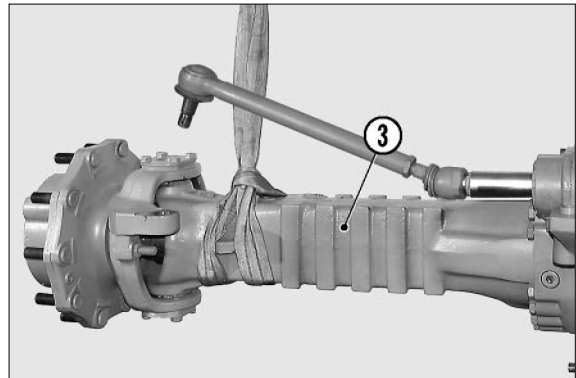

14W7RA153

## 10. THE BEVEL PINION

### 1) HOW TO REMOVE THE BEVEL PINION

- (1) Remove the complete arms and the differential unit.

For details, see “ CHECKING WEAR AND REPLACING THE BRAKING DISKS ”and “ REMOVING THE DIFFERENTIAL UNIT ”.

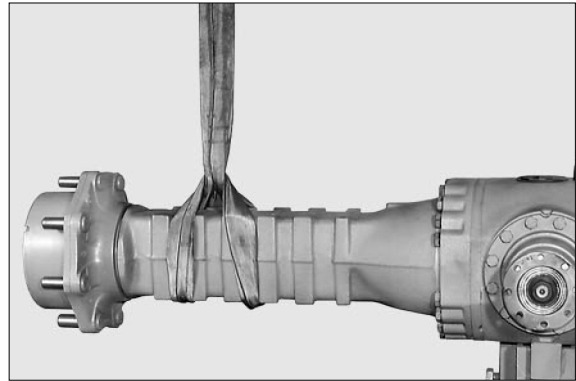

14W7RA061

- (2) If disassembly is awkward, heat the check nut(1) of the flange(2) at 80. C.

#### NOTE

Heating is meant to unloose the setting of loctite on the nut(1).

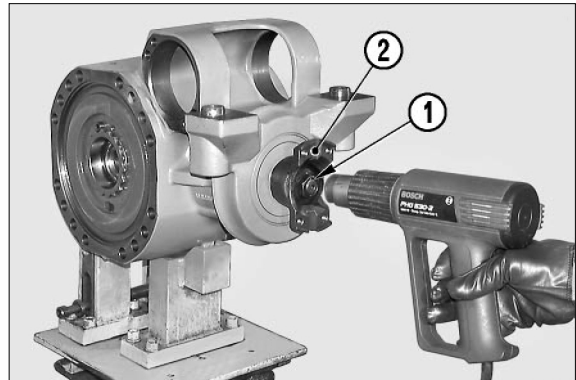

14W7RA062

- (3) Position tool T20A(or T20B), so as to avoid pinion rotation.

Unloose and remove the nut(1); also remove the O-ring(3).

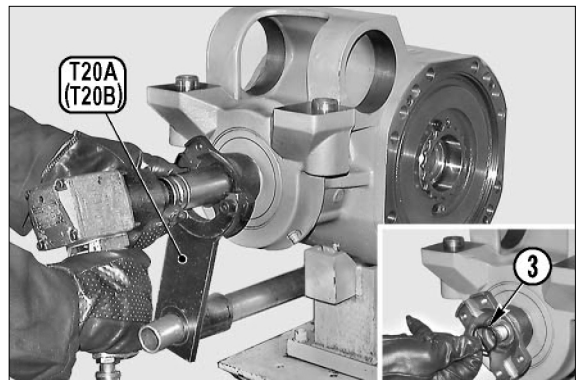

14W7RA063

- (4) Remove the flange(2) complete with guard(4) by means of a puller.

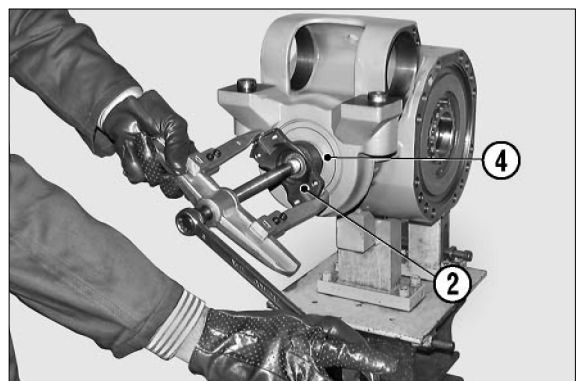

14W7RA064

- (5) Remove the swinging support(5).  
**Front axle only**

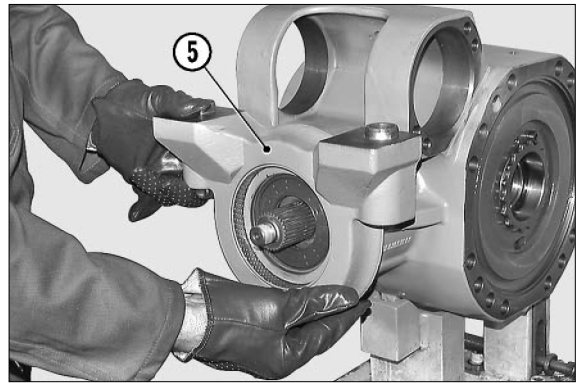

14W7RA065

- (6) Remove the sealing ring(6).

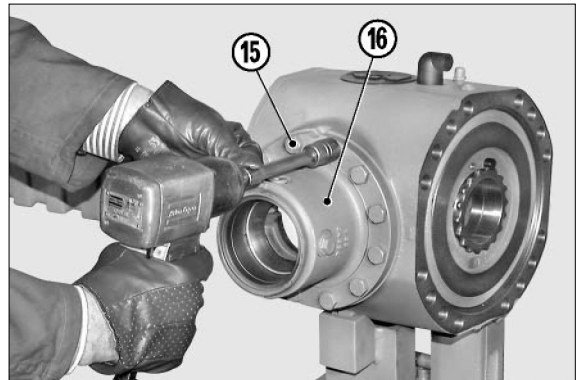

14W7RA066

- (7) Position wrench T22 onto the ring nut(7) and apply bar hold T21 to the pinion(8). Stop wrench T22 and rotate the pinion so as to release and remove the ring nut(7).

**NOTE**

If disassembly proves awkward, weld the ring nut at approx. 80, C.

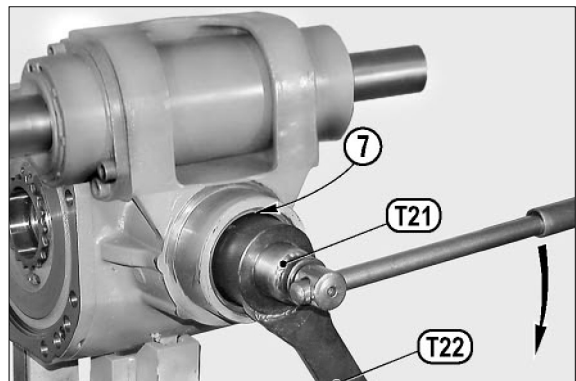

14W7RA070

- (8) Apply blocks T23 and, with the help of a puller, extract the pinion(8) complete with the internal bearing(9), the distance piece(10) and shims(11).

**NOTE**

The thrust blocks of the bearings remain in the central body(12).

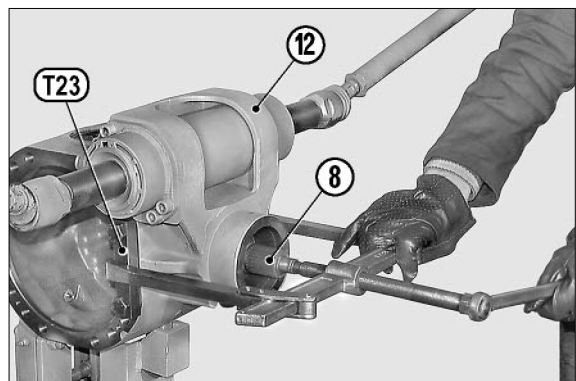

14W7RA071

(9) Remove the pinion(8), shims(11) and distance piece(10).

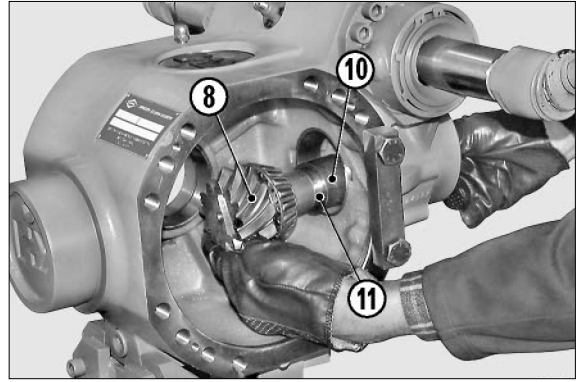

14W7RA072

(10) Using a puller and a press, remove the inner bearing(9) from the pinion(8).

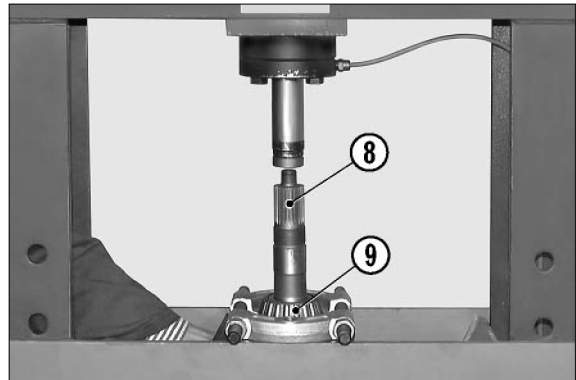

14W7RA073

(11) Remove the thrust block of the external bearing(13).

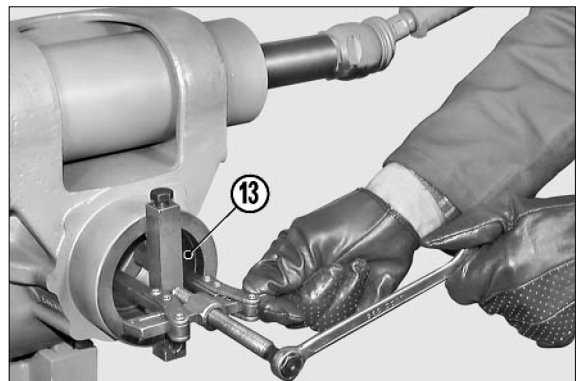

14W7RA074

(12) Insert a drift in the appropriate holes and remove the thrust block of the internal bearing(9) as well as the shim washers (14).

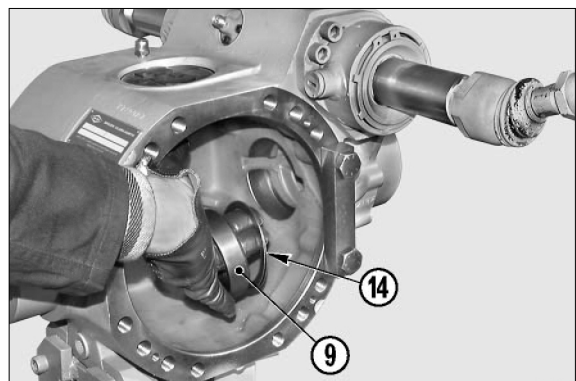

14W7RA075

**(13) ONLY IF NECESSARY**

**Rear axle only.**

Unloose and remove the screws(15) locking the support(16), remove the whole support.

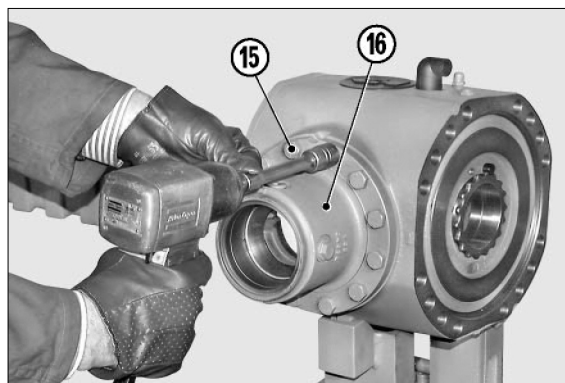

14W7RA067

## 2) HOW TO INSTALL AND ADJUST THE BEVEL PINION

### (1) ONLY IF HAS BEEN REMOVED

Fit support(16), including O-ring(20), onto the intermediate body.

#### NOTE

The cavity located on the outer diameter must face upwards.

Check and lubricate the O-ring(20).

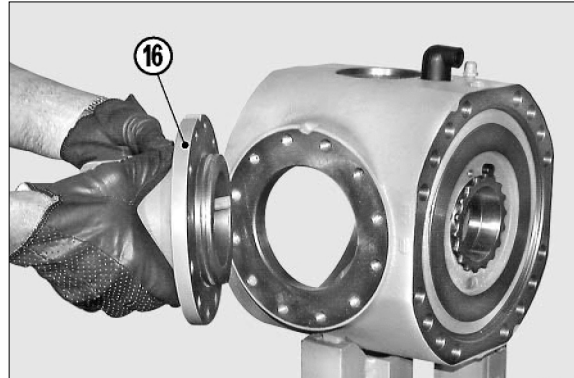

14W7RA076

(2) Fasten support with screws(15) previously coated with loctite 270.

Tighten using the criss-cross method to a tightening torque of 9~10kgf · m(65~72lb · ft)

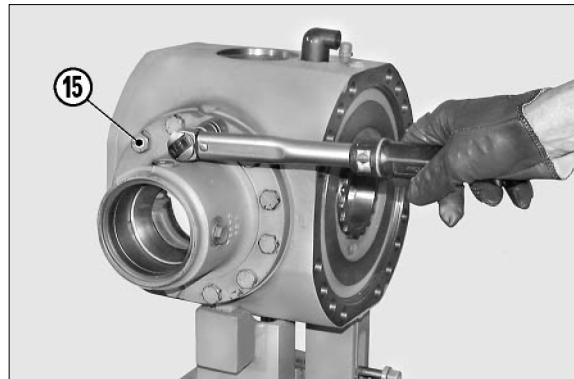

14W7RA077

(3) Using a surface plate, reset a centesimal comparator " DG " and place it on the measurement ring T24 (with a thickness of 30.2mm).

Preset the comparator to approx. 2mm

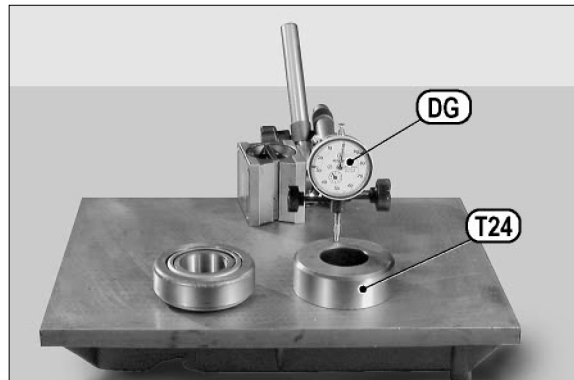

14W7RA078

(4) Bring the internal bearing(9), complete with its thrust block, under the comparator " DG ". Determine overall thickness " D " of the bearing checking the discrepancy between this size and the size of the measurement ring.

**Press the thrust block in the centre and take several measurements while rotating the thrust block.**

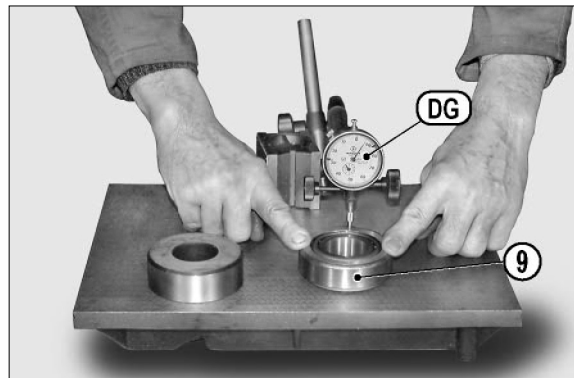

14W7RA079

- (5) Partially insert the thrust block of the external bearing(13).

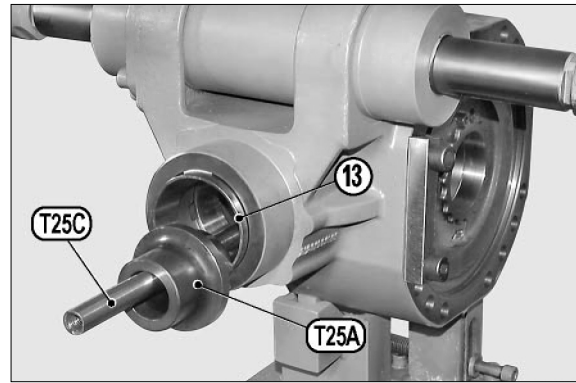

- (6) Install tension rod T25C, measurement ring T24 and front guide tool T25A on the thrust block of the external bearing(13).

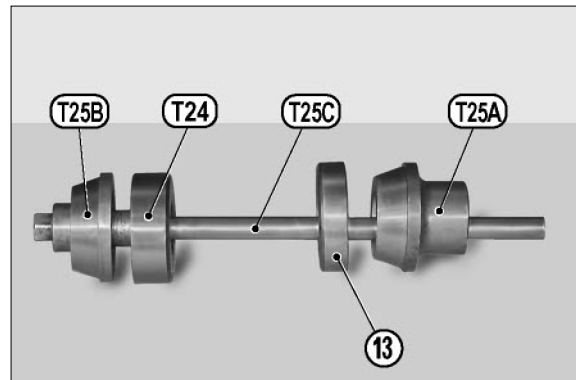

- (7) Connect the tension rod to the press and move the thrust block of the external bearing(13) into its seat. Disconnect the press and remove the tension rod.

**NOTE**

Before starting the next stage, make sure that the thrust block has been completely inserted into its seat.

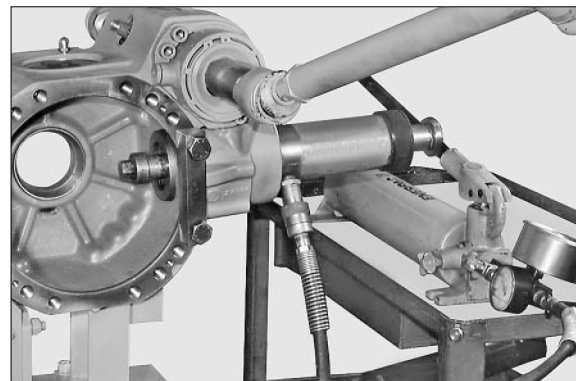

- (8) Insert tool T26B complete with external bearing(13), measurement ring T24 and gauged ring nut T26C. Manually tighten.

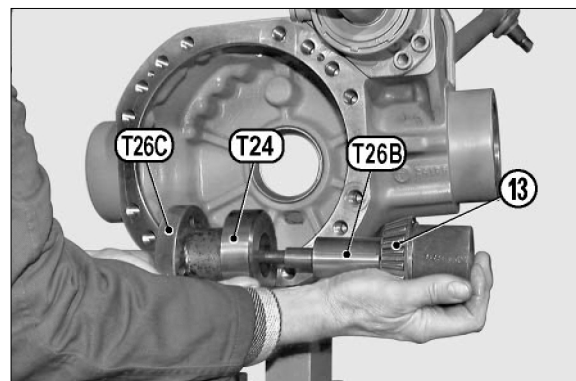

- (9) Fit a centesimal comparator " DG1 " with long stem into bar T26A; when the bar rests on two size-blocks " GB " of 57mm, reset the comparator.
- Preset the comparator to approx. 2mm and reset.

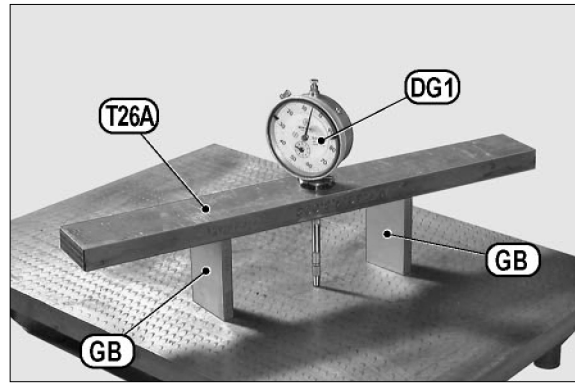

14W7RA084

- (10) Lay bar T26A on gauged nut T26C and take the size " A " at about 57mm corresponding to the maximum diameter of arms centering.

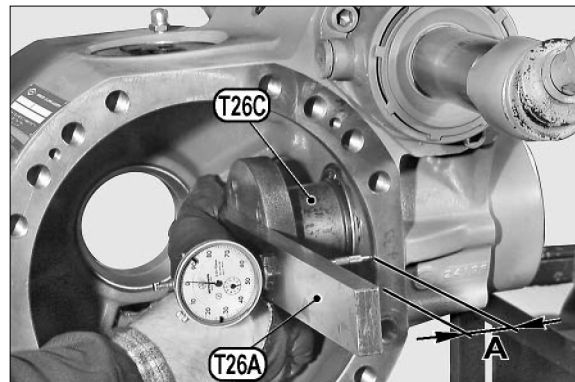

14W7RA085

- (11) Calculate size " B " which will be the first useful valve for calculating the size of the shims(14) that are to be inserted under the thrust block of the internal bearing(9).

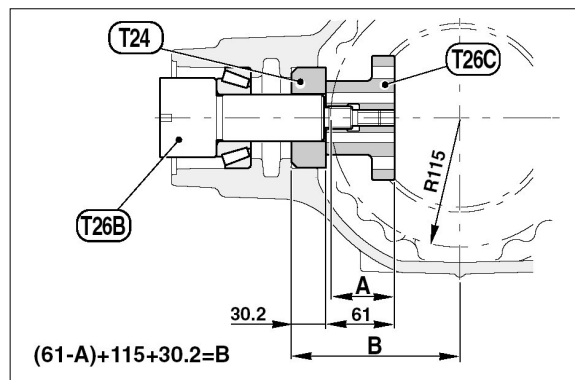

14W7RA086

- (12) Check the nominal size(X) marked on the pinion and add or subtract the indicated variation(Y) so as to obtain size " Z ".
- e.g;  $Z=118+0.1=118.1$   
 $Z=118-0.2=117.8$

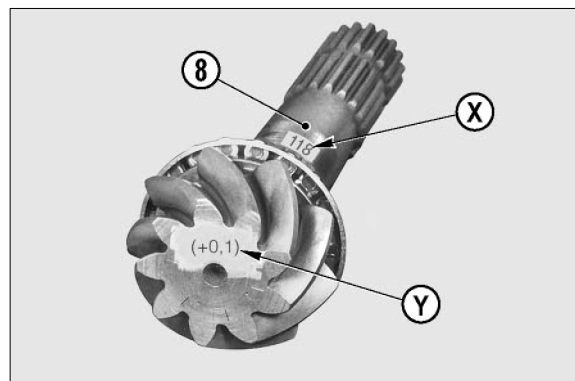

14W7RA087

- (13) Calculate size " C " which represents the second value for calculating the size of the shims " S " that are to be placed under the thrust block of the internal bearing(9).

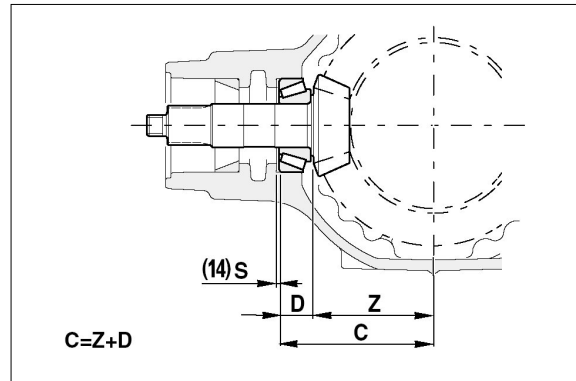

14W7RA088

- (14) Calculate the difference between sizes " B " and " C " so as to obtain the size " S " of the shim(14) that will go under the thrust block of the internal bearing(9).

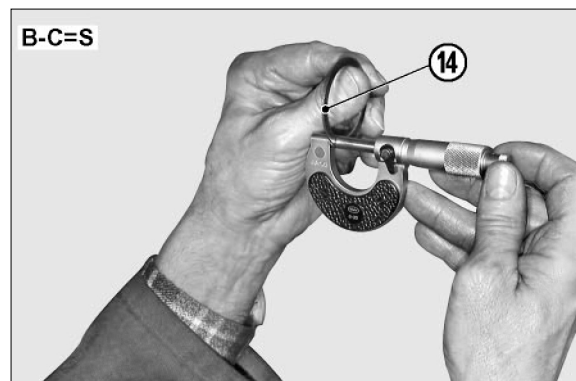

14W7RA089

- (15) Insert shim " S "(14) and the thrust block of the internal bearing(9) in the central body.  
**NOTE**  
 To hold shim " S "(14) in position, apply grease.

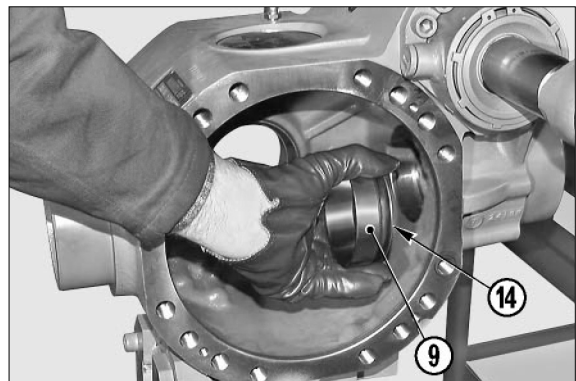

14W7RA090

- (16) Position tool T25A and tension rod T25C.  
 Connect the tension rod to the press, fasten the thrust block and then remove the tools.  
**NOTE**  
 Before going on to the next stage, make sure that the thrust block has been completely inserted.

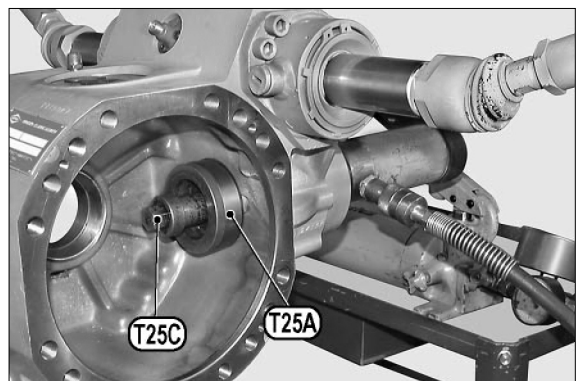

14W7RA091

- (17) Position tools T26C and T26B complete with tapered bearings(9) and (13); manually tighten until a rolling torque has been obtained.

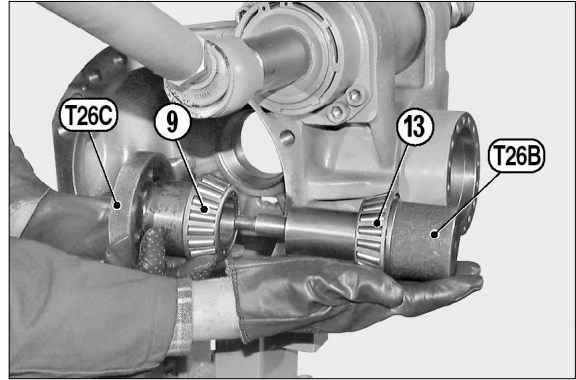

14W7RA092

- (18) Insert the stem of a depth comparator " DDG " in either side hole of tool T26C; reset the comparator with a presetting of approx. 3mm.

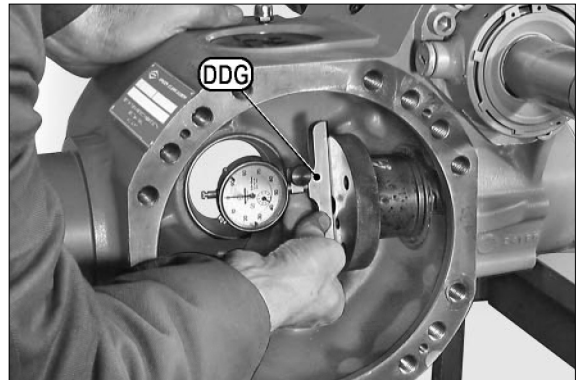

14W7RA093

- (19) Remove the comparator and release tools and bearings from the central body. Re-install all and insert the distance piece(10) between bearings(9) and (13); manually tighten the whole pack.

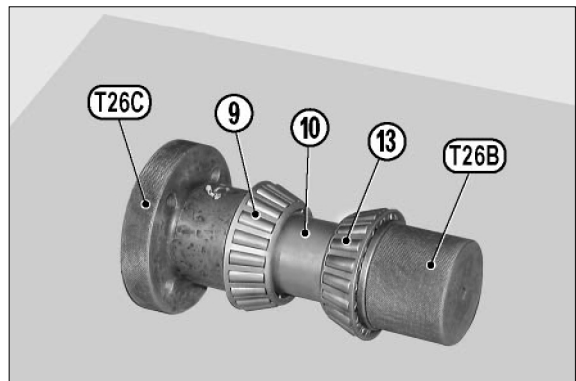

14W7RA094

- (20) Insert depth comparator " DDG " into tool T26B-T26C and measure variation " H " in relation to the zero setting performed back at point d.

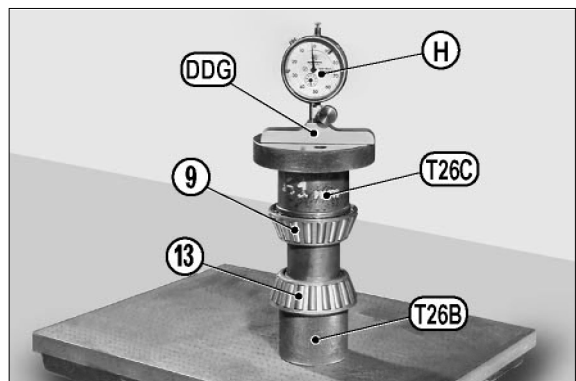

14W7RA095

(21) The variation is to be added to a set value of 0.12~0.13mm, so as to obtain the size of shim " S1 "(11) which will be inserted between the external bearing(13) and the distance piece(10) and subsequently, to determine the preload for the bearings.

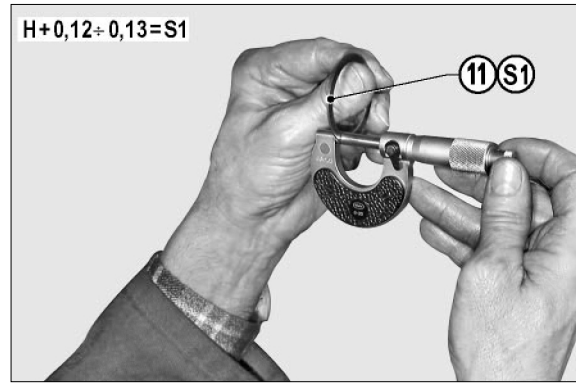

14W7RA096

(22) Position the internal bearing(9) and the pinion(8) under a press; force the bearing onto the pinion.

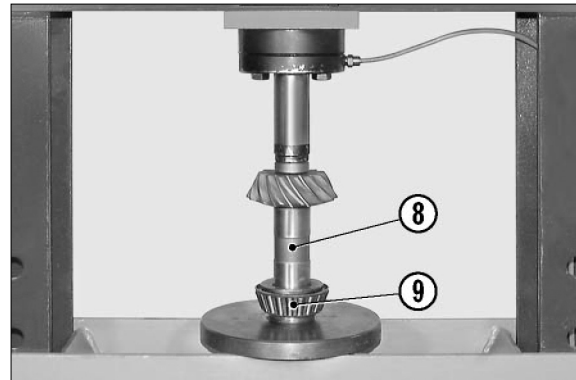

14W7RA097

(23) Fit the pinion(8), shim " S1 "(11) and distance piece(10) in the main body(12).

**NOTE**

The finer shims must be placed in-between the thicker ones.

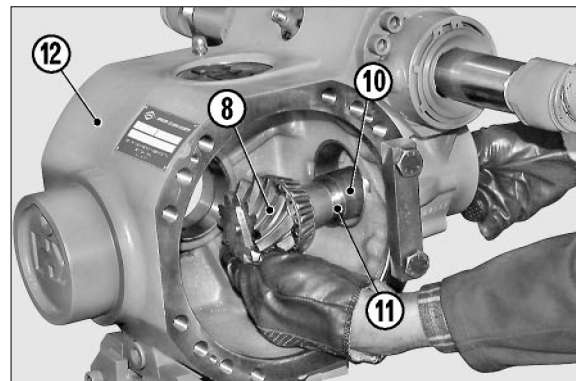

14W7RA098

(24) Insert the external bearing(13) in the central body in order to complete the pack arranged as in the figure.

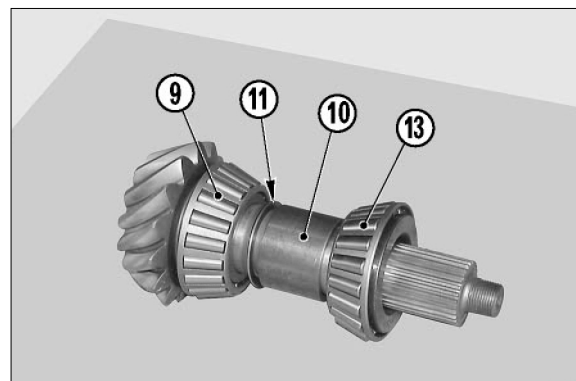

14W7RA099

(25) Connect the pinion(8) to the tie rod T28A and T28B; connect the tie rod T28C (see special tools) to the press and block.

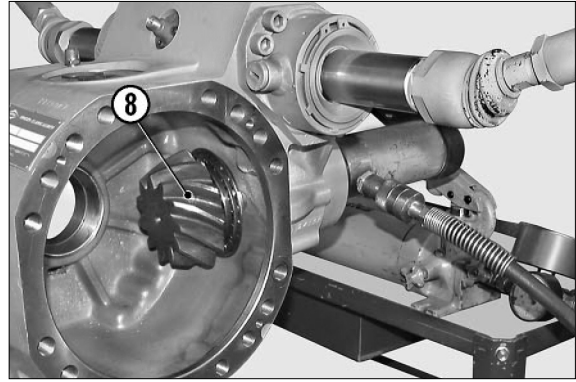

14W7RA100

(26) Apply loctite 242 to the thread of the ring nut(7) and screw the nut onto the pinion(8).

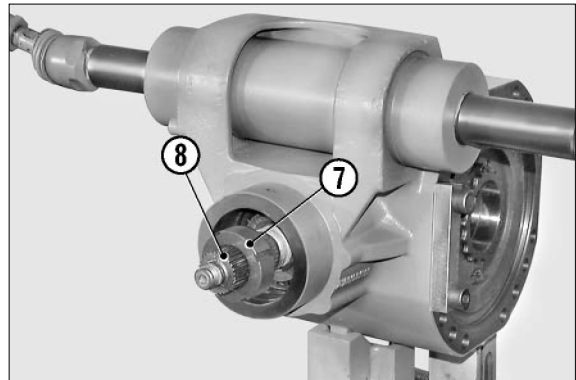

14W7RA101

(27) Apply special wrench T22 to the ring nut(7) and bar-hold T21 to the pinion(8). Lock the wrench T22 and rotate the pinion using a dynamometric wrench, up to a minimum required torque setting of 50kgf · m(362lbf · ft)

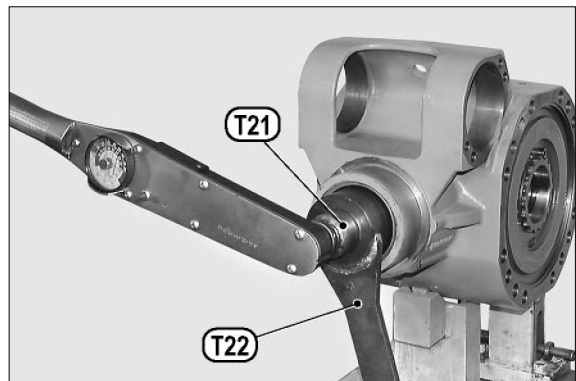

14W7RA102

(28) Apply onto the pinion(8) the bar-hold and with the help of a torque metre, check the torque of the pinion(8).

- Torque : 12~17kgf · m(87~123lbf · ft)

If torque exceeds the maximum value, then the size of shim " S1 " (11) between the bearing(13) and the distance piece(10) needs to be increased.

If torque does not reach the set value, increase the torque setting of the ring nut(7) in different stages to obtain a maximum value of 57kgf · m(412lbf · ft). If torque does not reach the minimum value, then the size of shim " S1 " (11) needs to be reduced.

When calculating the increase or decrease in size of shim " S1 ", bear in mind that a variation of shim(11) of 0.01mm corresponds to a variation of 0.06kgf · m(0.43lbf · ft) in the torque of the pinion(8).

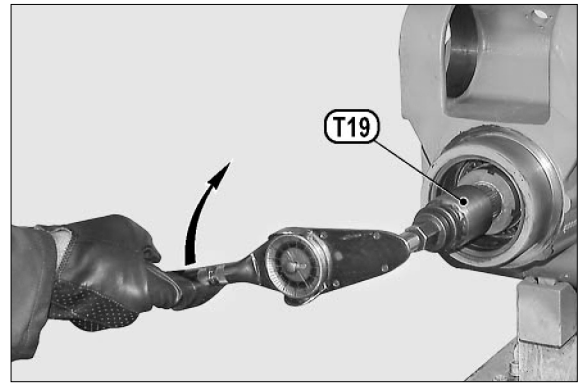

14W7RA103

(29) Lubricate the outer surface of the new sealing ring(6) and fit it onto the central body(12) using tool T27.

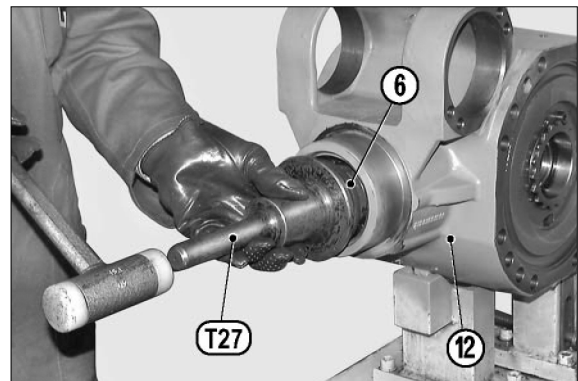

14W7RA104

(30) Install the swinging support(5).

※ **Front axle only.**

**NOTE**

Check that it is properly oriented.

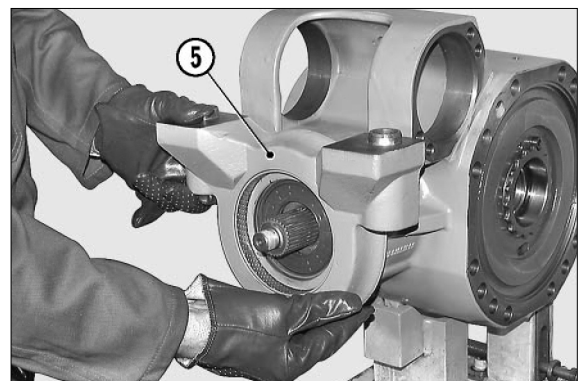

14W7RA105

(31) Fit the flange(2) complete with the guard(4) and fasten it.  
For keying the flange(2), use a plastic hammer if necessary.

**NOTE**

Make sure that the guard(4) is securely fastened onto the flange and that it is not deformed.

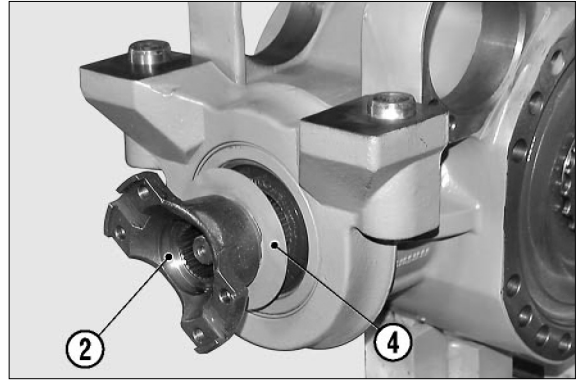

14W7RA106

(32) Apply loctite 242 to the threaded part of the pinion(8). Position tool T20A(or T20B) and fasten it in order to avoid rotation. Insert O-ring(3) the nut(1) and tighten it using a dynamometric wrench.

- Torque wrench setting : 28~31kgf · m  
(203~224lb · ft)

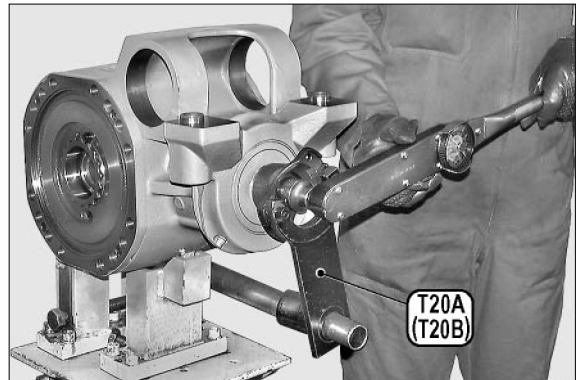

14W7RA107

(33) Remove blocks T23(used for extracting the pinion) and re-install the arms.  
For details, see“ CHECKING WEAR AND REPLACING THE BRAKING DISKS ”.

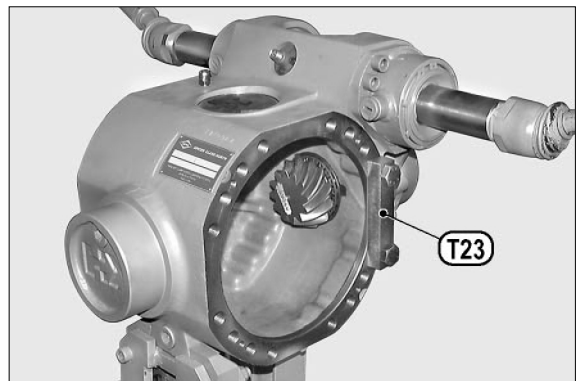

14W7RA108

# 11. SPECIAL TOOLS

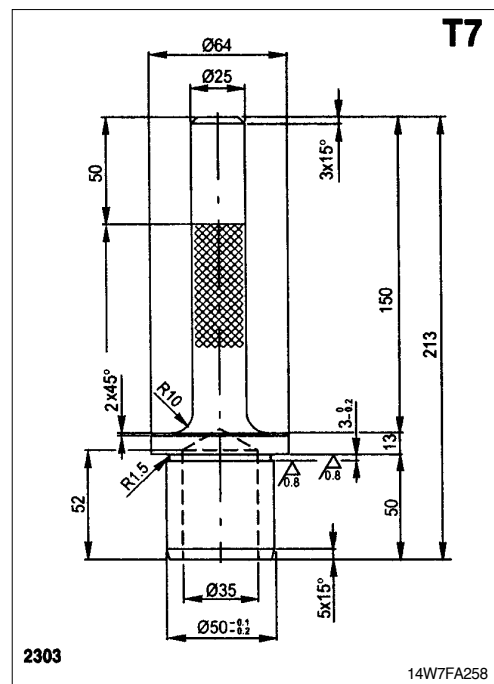
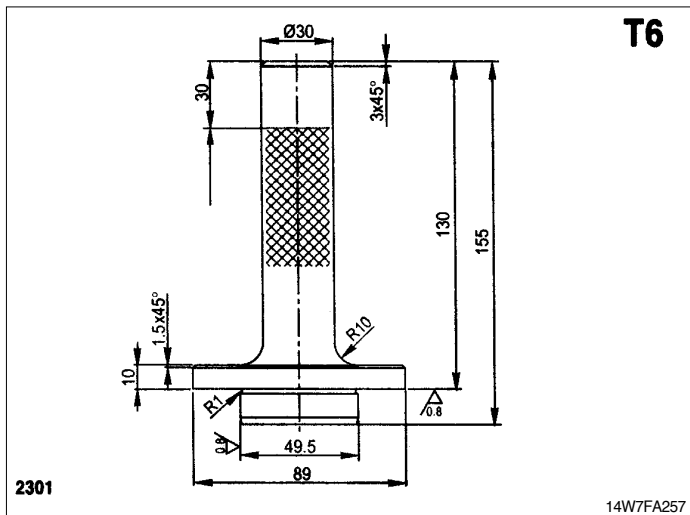
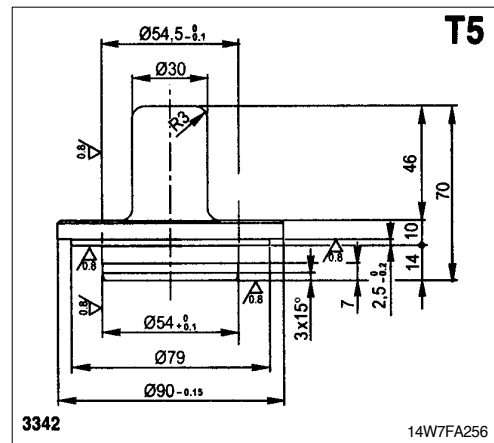
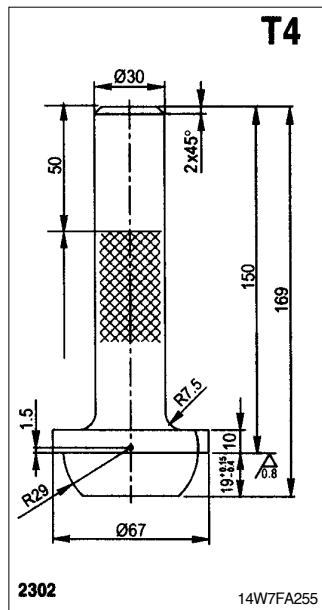
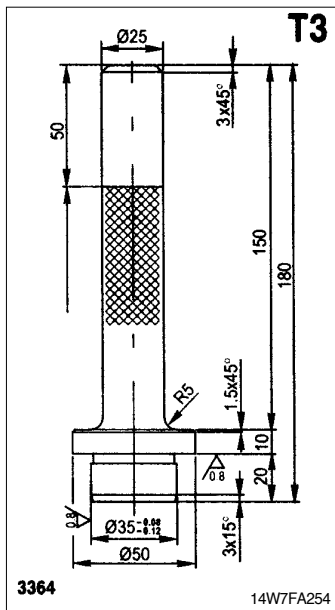
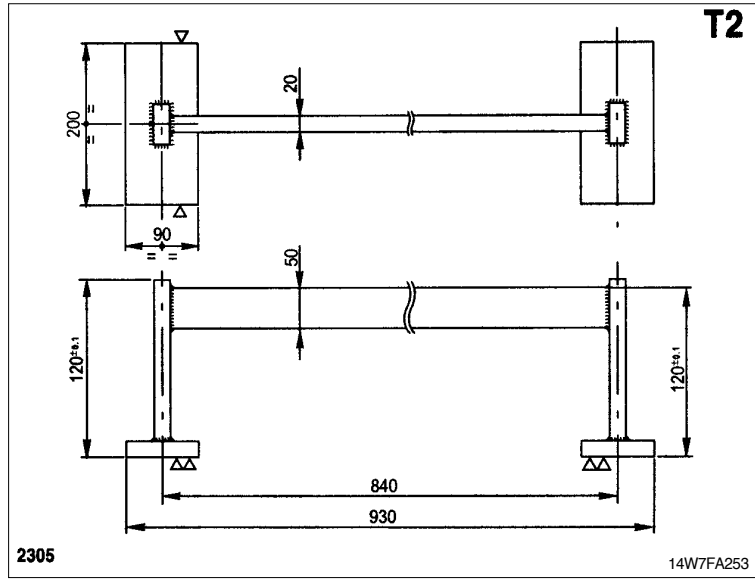
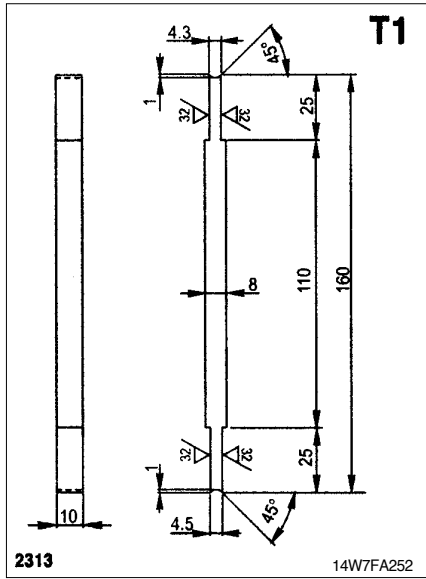

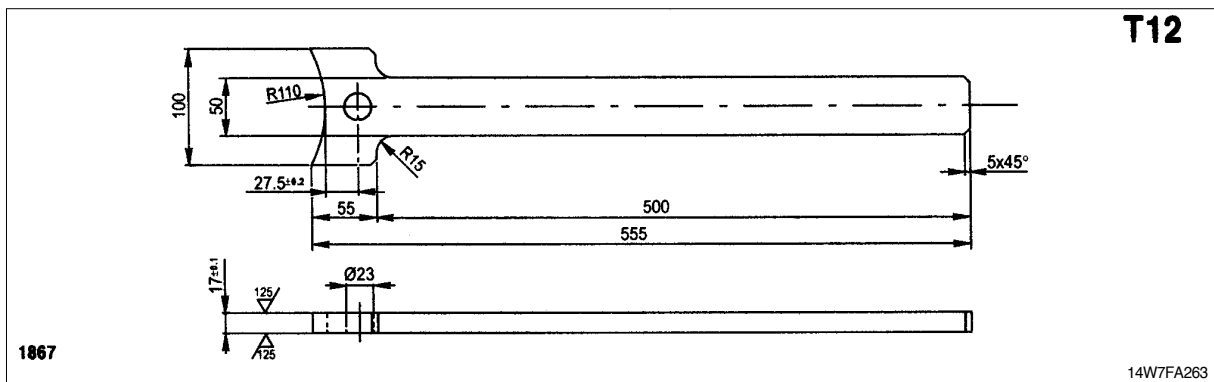
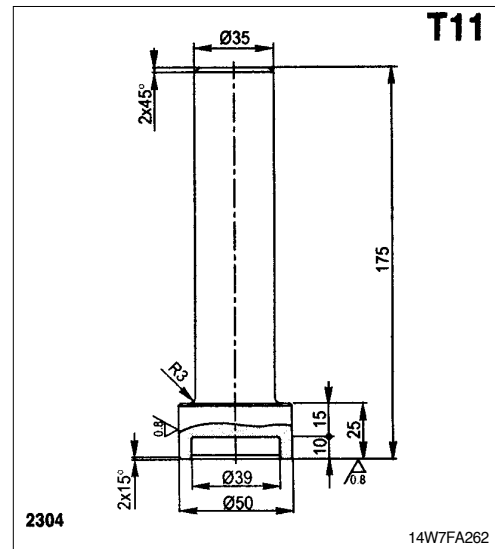
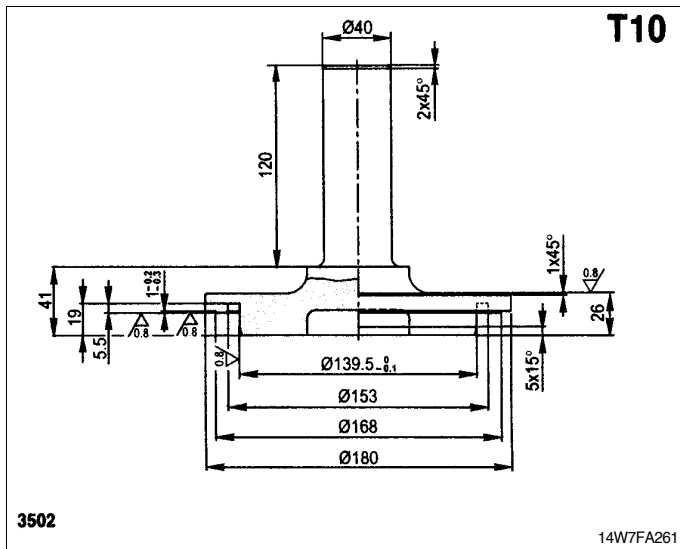
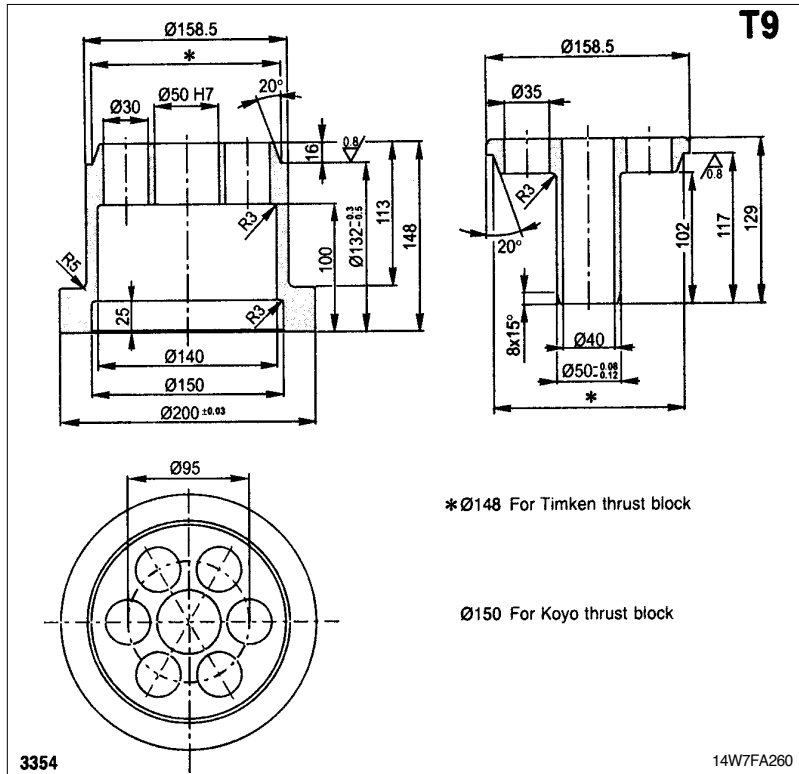
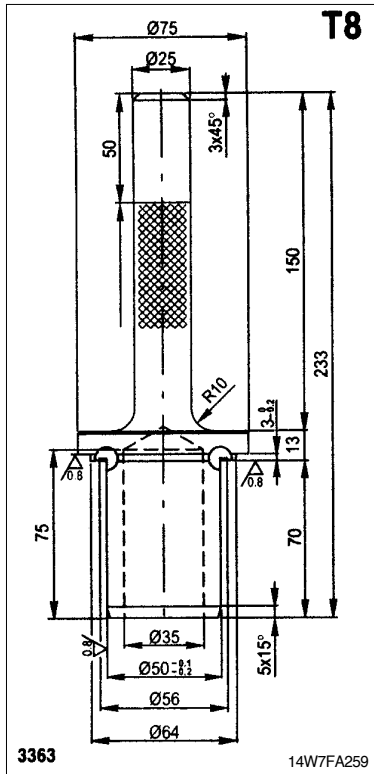

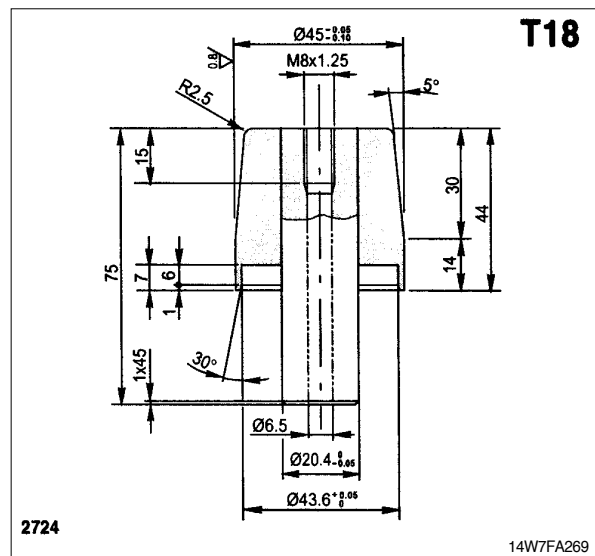
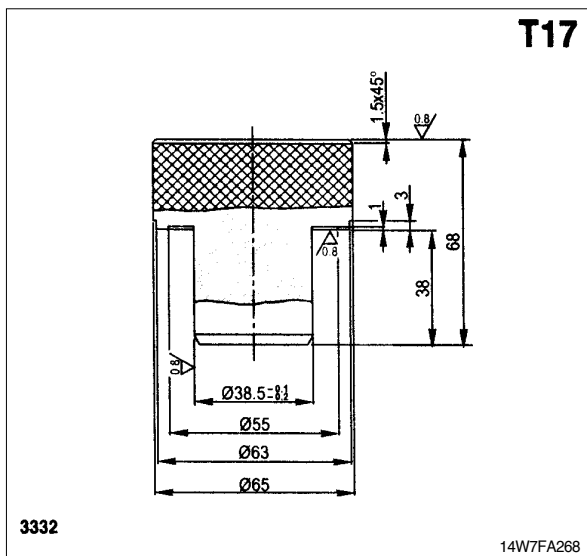
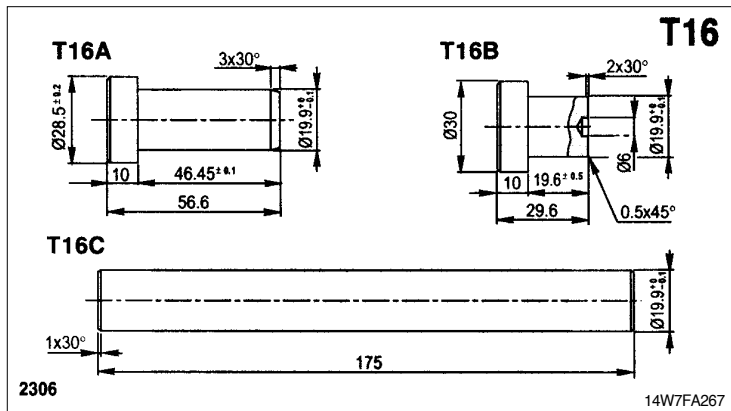
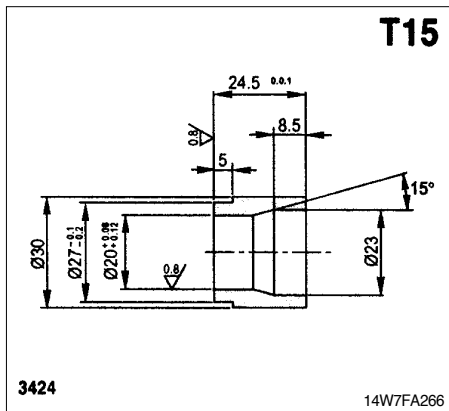
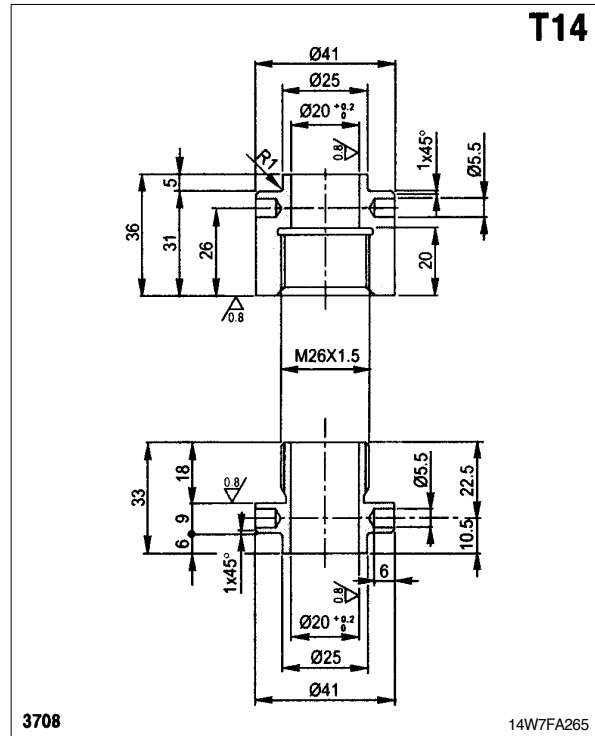
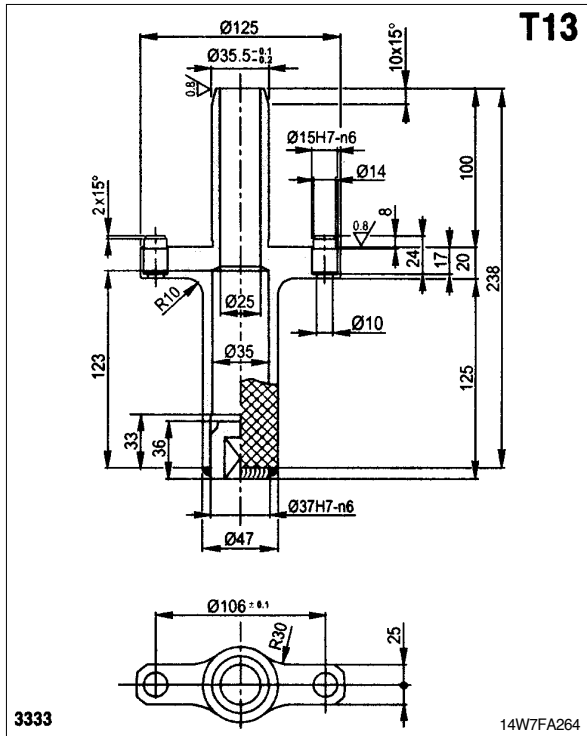

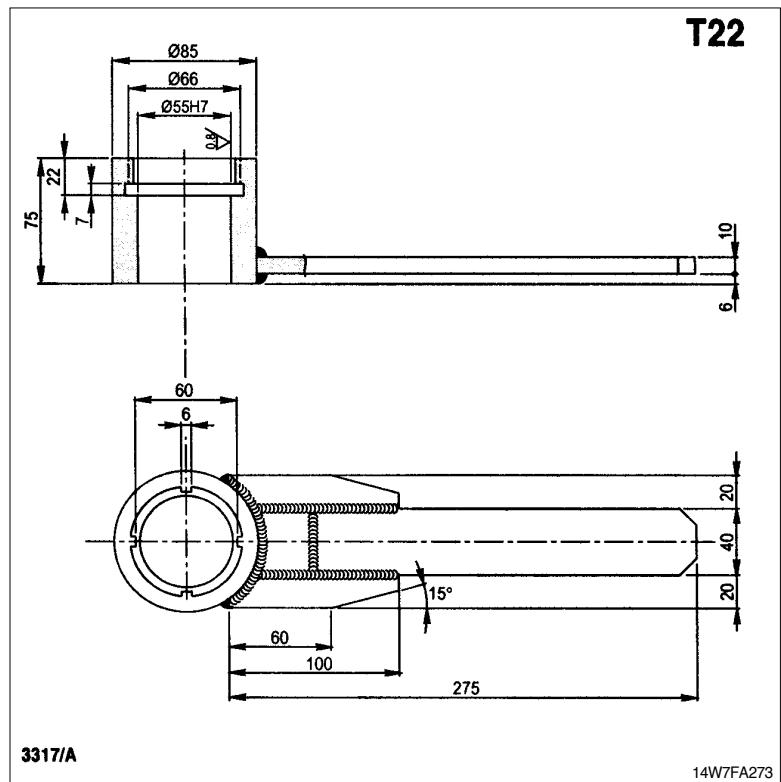
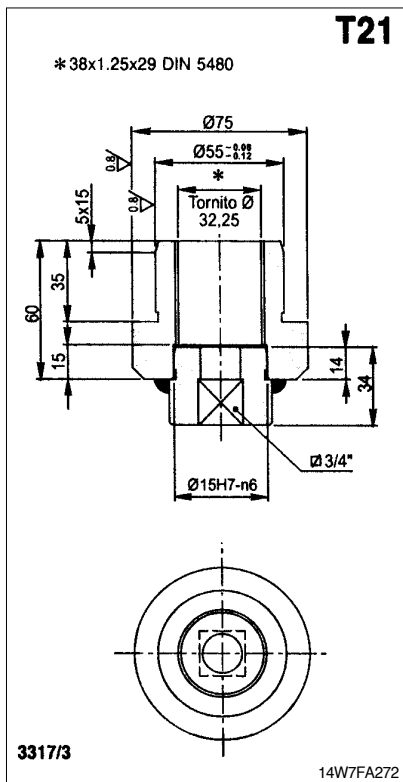
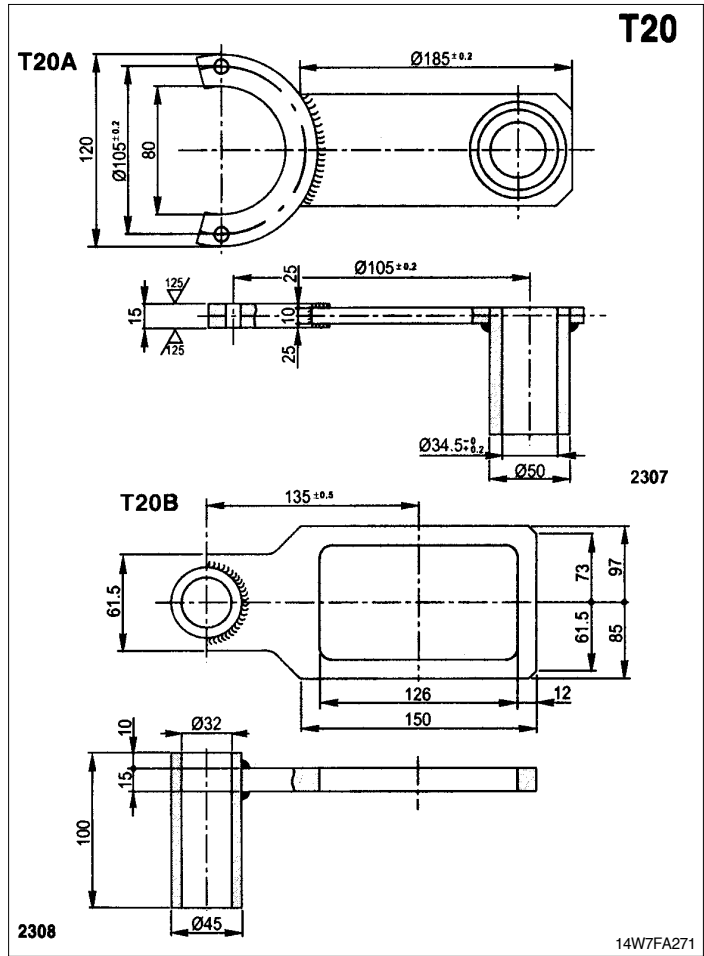
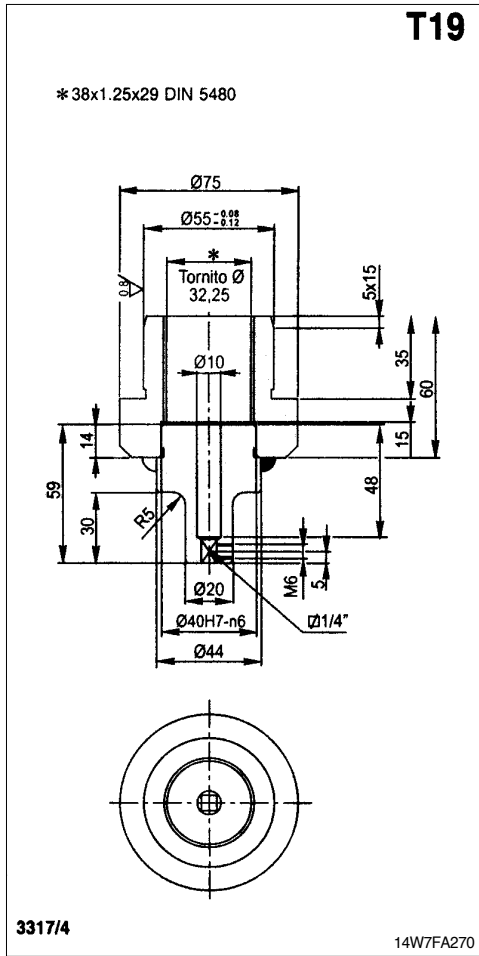

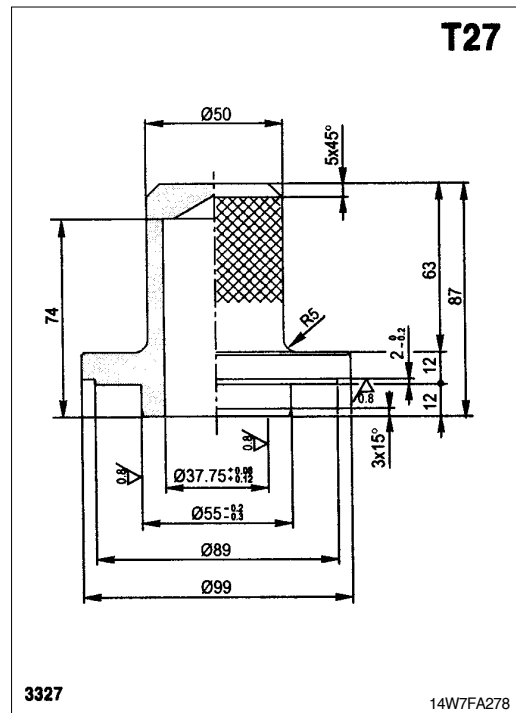
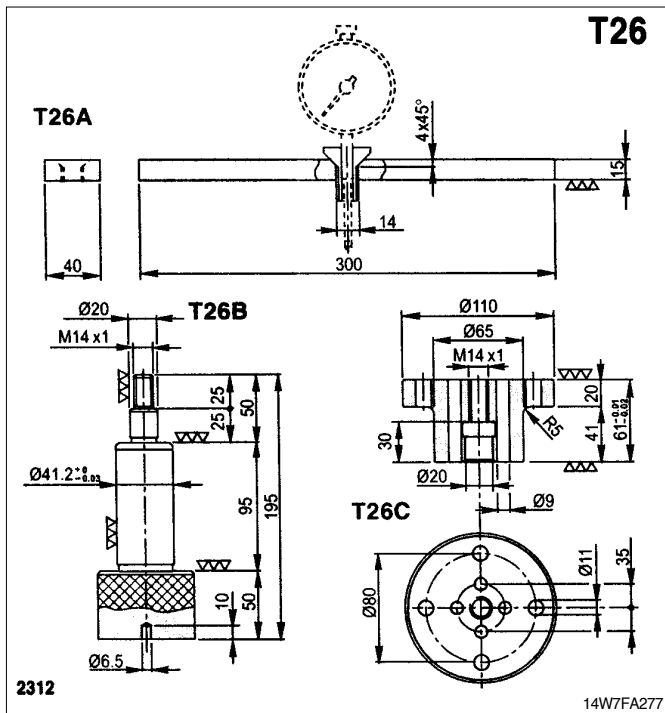
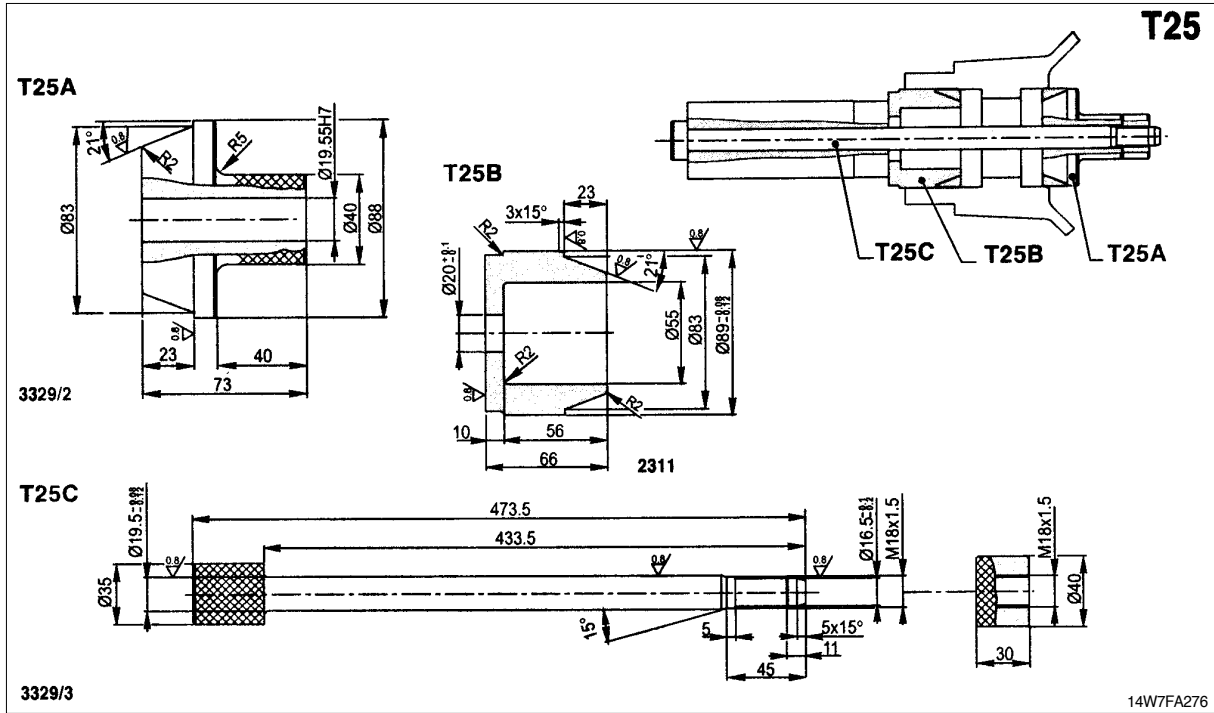
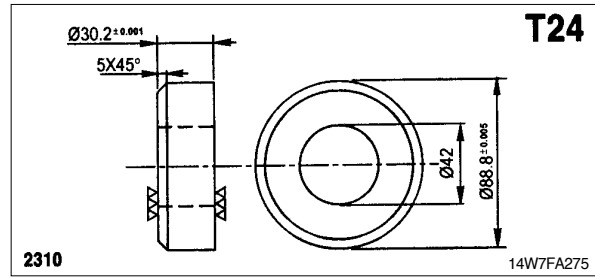
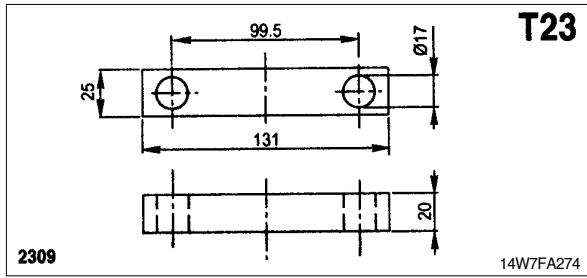

T28

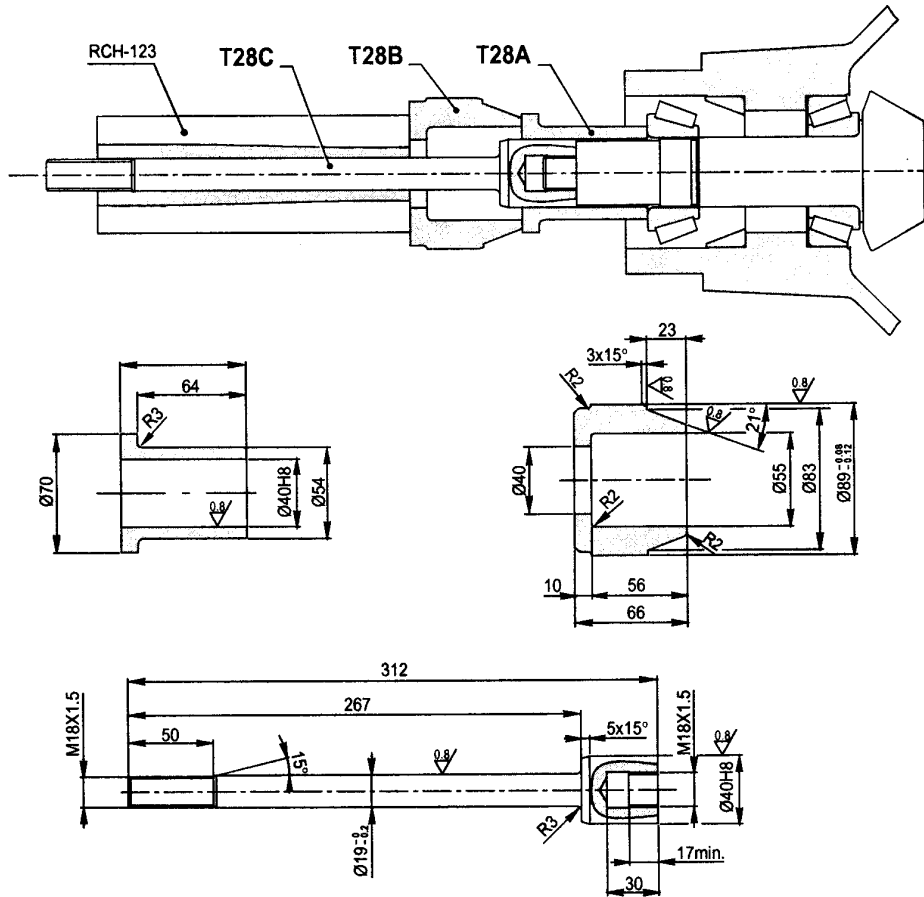

3329

14W7FA279

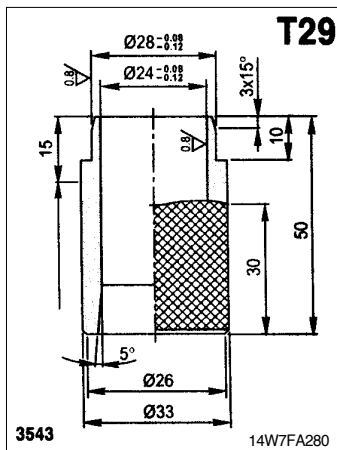

3543

14W7FA280

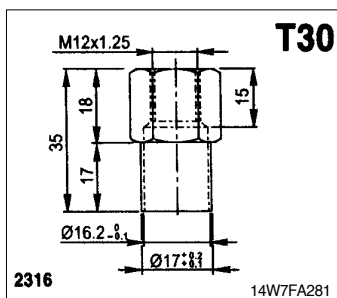

2316

14W7FA281

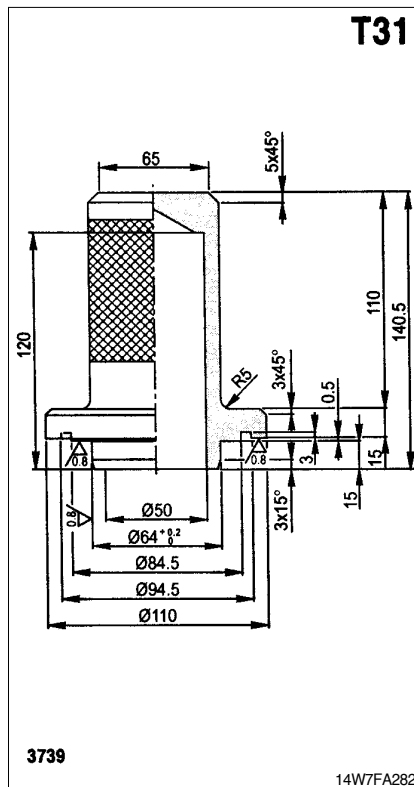

3739

14W7FA282

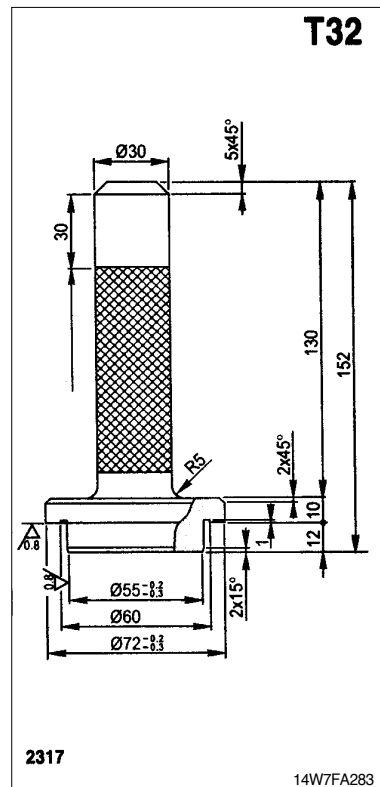

2317

14W7FA283