

GROUP 5 SWING DEVICE

1. REMOVAL AND INSTALL OF MOTOR

1) REMOVAL

- (1) Lower the work equipment to the ground and stop the engine.
- (2) Operate the control levers and pedals several times to release the remaining pressure in the hydraulic piping.
- (3) Loosen the breather slowly to release the pressure inside the hydraulic tank.
- ▲ Escaping fluid under pressure can penetrate the skin causing serious injury. When pipes and hoses are disconnected, the oil inside the piping will flow out, so catch it in oil pan.
- (4) Disconnect hose assembly(2).
- (5) Disconnect pilot line hoses(4,5,6,7,8,9).
- (6) Sling the swing motor assembly(1) and remove the swing motor mounting bolts (10).

Motor device weight : 36kg(79.4lb)

- (7) Remove the swing motor assembly.
When removing the swing motor assembly, check that all the piping have been disconnected.

2) INSTALL

- (1) Carry out installation in the reverse order to removal.
- (2) Bleed the air from the swing motor.
Remove the air vent plug.
Pour in hydraulic oil until it overflows from the port.
Tighten plug lightly.
Start the engine, run at low idling and check oil come out from plug.
Tighten plug fully.
- (3) Confirm the hydraulic oil level and check the hydraulic oil leak or not.

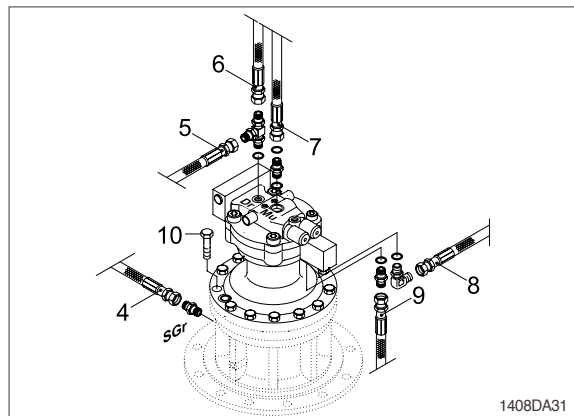
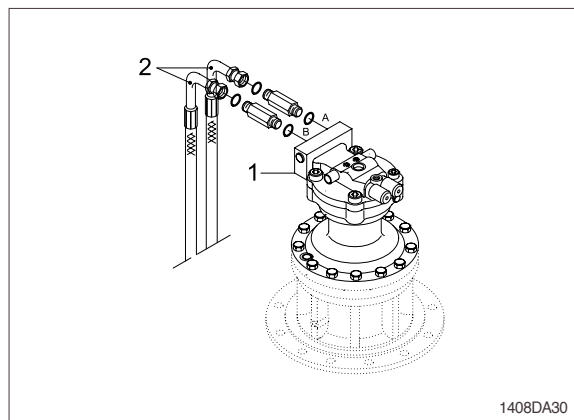

2. DISASSEMBLY AND ASSEMBLY OF SWING MOTOR

1) STRUCTURE

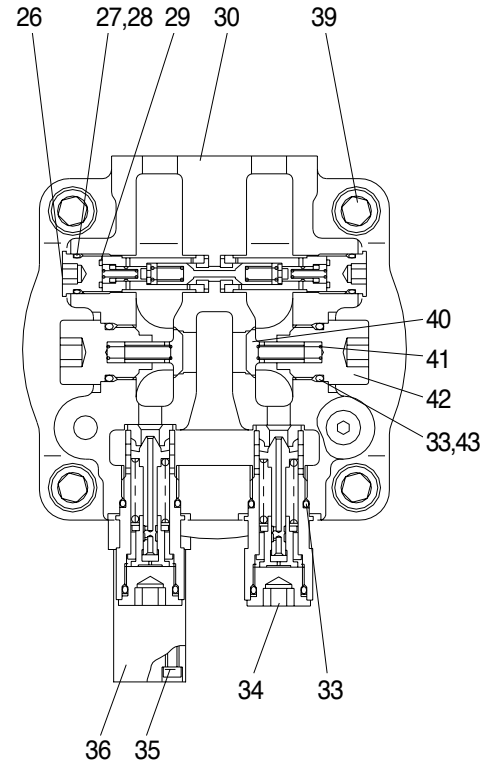
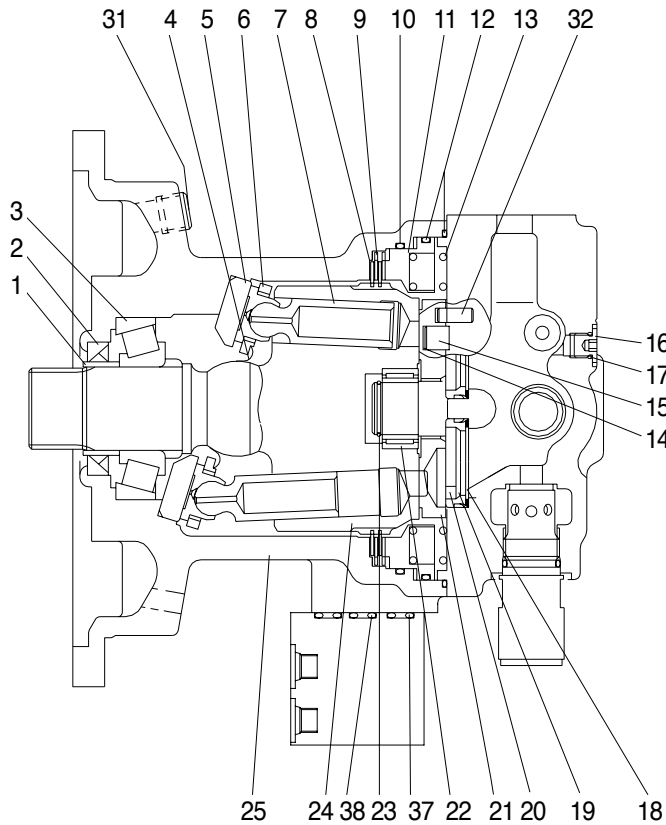

14072SF50

1	Inner ring	15	Piston	29	O-ring
2	Oil seal	16	Cap	30	Cover
3	Tapered roller bearing	17	O-ring	31	Plug
4	Backing spring	18	Scrowave	32	Parallel pin
5	Cam plate	19	Teflon ring	33	O-ring
6	Return plate	20	Bush	34	Relief valve
7	Piston assembly	21	Balance plate	35	Bolt
8	Lining plate	22	Needle bearing	36	Time delay valve
9	Plate	23	Snap ring	37	O-ring
10	O-ring	24	Cylinder assembly	38	O-ring
11	Piston	25	Housing	39	Bolt
12	O-ring	26	Bypass valve assy	40	Check
13	Spring	27	Back-up ring	41	Spring
14	Teflon ring	28	O-ring	42	Cap
				43	Back-up ring

2) DISASSEMBLY

(1) Removal of relief valve assembly

Remove cap of relief valve assembly(34) with 14mm hexagonal wrench.

Assemble removed relief valve assembly (34) to original state when reassembling.

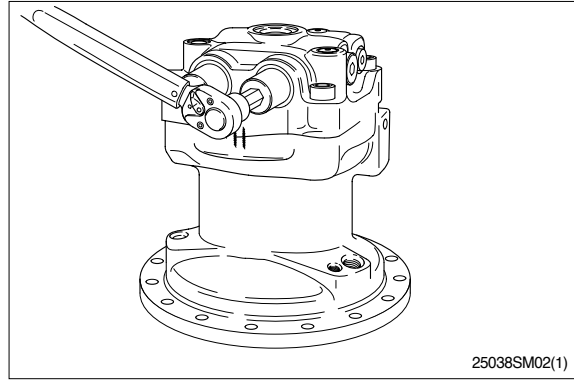

(2) Removal of make up valve and bypass valve assembly

Loosen cap(42) with 14mm hexagonal wrench, and remove check valve(40) and spring(41).

Remove bypass valve assembly(26) with 10mm hexagonal wrench.

Assemble removed bypass valve assembly(26) to original state when reassembling.

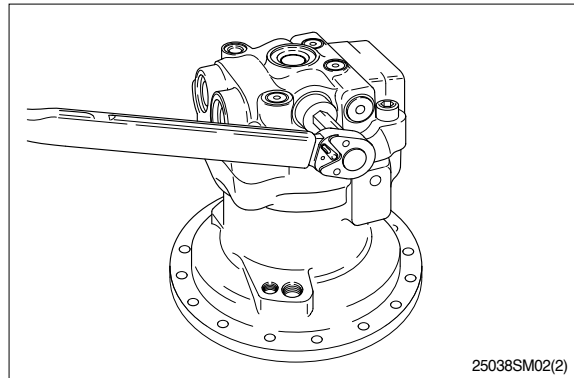

(3) Marking at swing motor

Before disassembling motor, make a matching mark between cover(30) and housing(25) for easy reassembling.

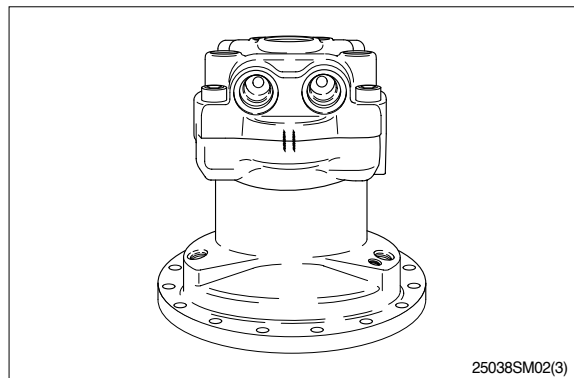

(4) Remove mounting bolts of cover

Loosen hexagon socket bolt(39) with 12mm hexagonal wrench.

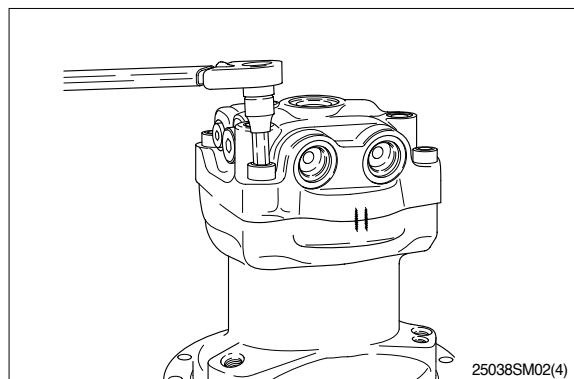

(5) Removal of cover assembly

Place shaft of motor assembly to downward and take cover(30) out.

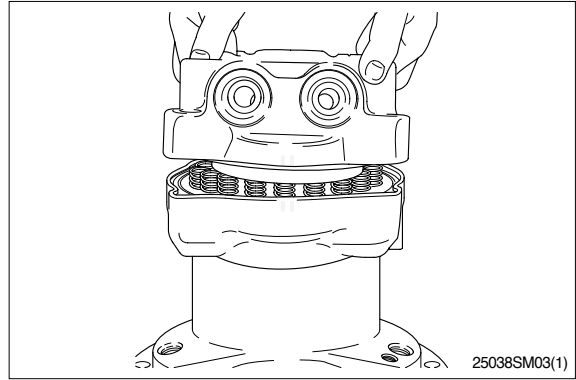

(6) Remove snap ring(23) with steel pointer and remove inner race of needle bearing (22) by bearing puller.

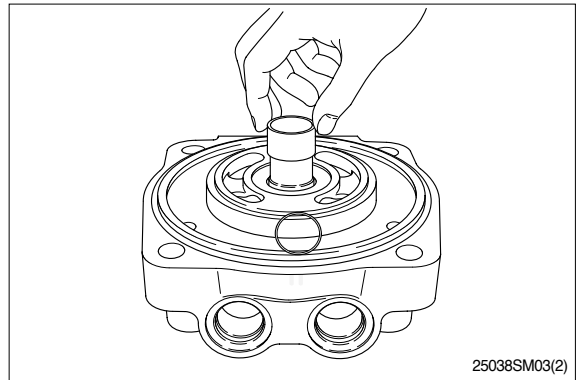

(7) Remove O-ring(12) from cover.

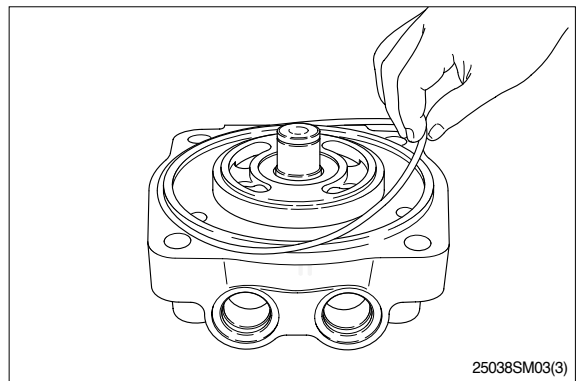

(8) Remove balance plate

Balance plate(21) is adhered on end surface of cylinder(24) by oil viscosity. Take off balance plate(21) with hands. Assembling method of balance plate(21) depends on cover(30).

(Band groove and round groove of high · low pressure transmission area)

Before removing, check and record location of balance plate(21) to prevent misassembling.

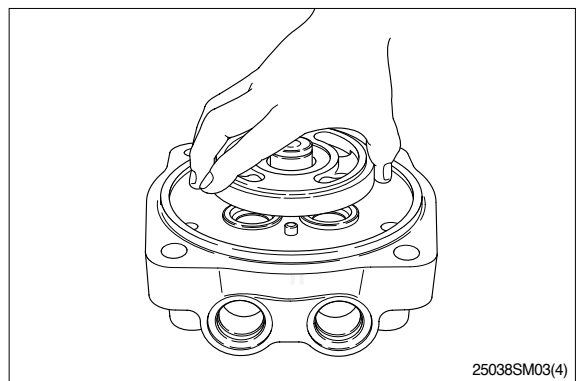

- (9) Remove bushing(20) and scrowave(18) from teflon ring(19).

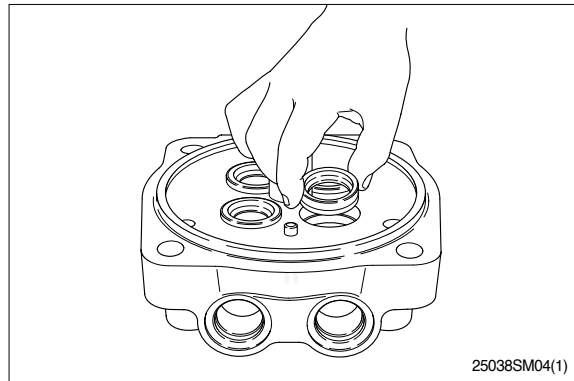

- (10) Removal of spring(13, brake area)**
Remove spring(13) from piston(11).
Check and record original position of each spring(13) for correct assembling.

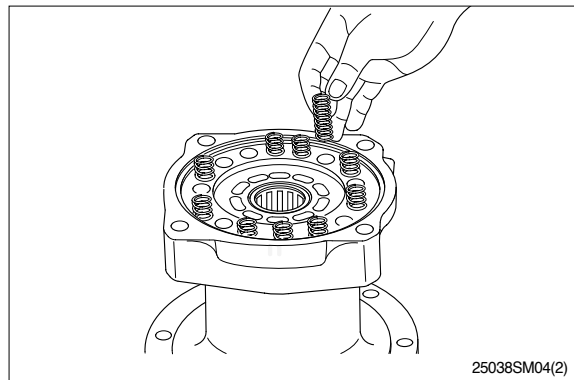

- (11) Removal of brake piston**
When removing piston(11) from housing (25), there is a sliding resistance against tightening of O-rings(10,12). Use tap hole(M6) on piston(11) as shown in the picture.

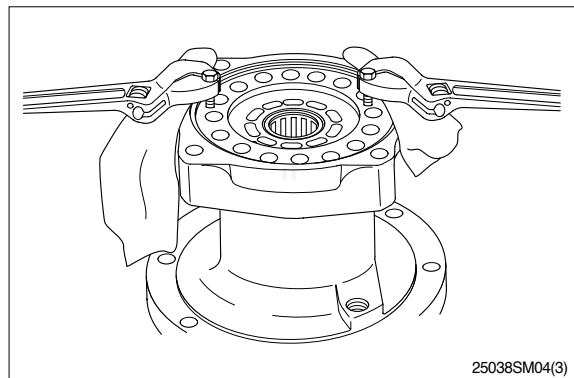

- (12) Remove O-rings(10,12) from piston(11) and housing(25).

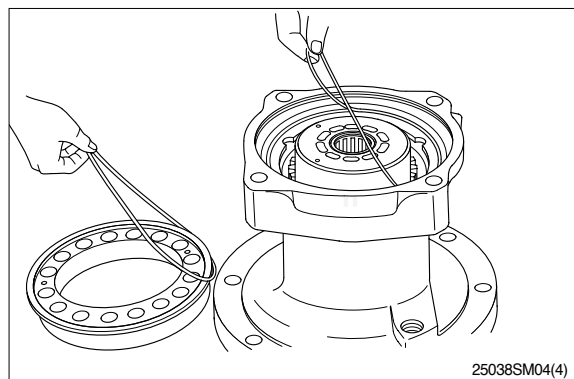

- (13) Remove friction plate(9) and lining plate (8) from housing(25).



(14) Removal of cylinder assembly

Holding end of cylinder assembly(24) with hand, draw out cylinder assembly from housing.

Oil seal(2) and outer race of taper roller bearing(3) are left inside of housing.

End surface of cylinder(24) is sliding face . So, protect the surface with a scrap of cloth against damage.

Make a matching mark on piston hole of cylinder(24) and piston assembly(7) to fit piston into the same hole when reassembling.

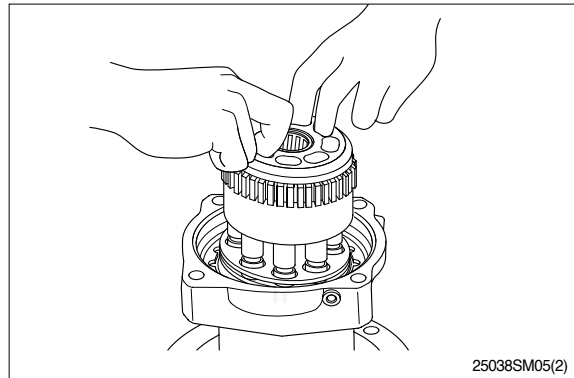

- (15) Separate outer race of taper roller bearing(3) from housing.

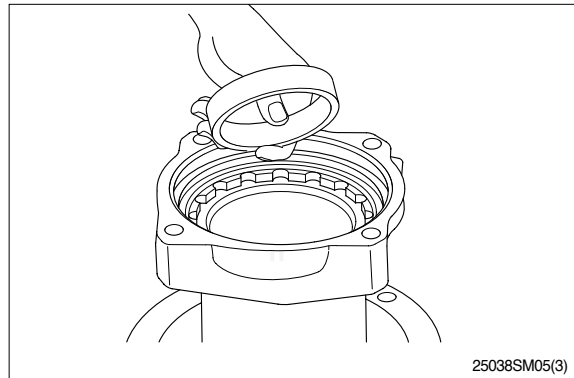

(16) Removal of oil seal

Remove oil seal(2) from housing(25) with driver and hammer.

Do not reuse oil seal after removal.

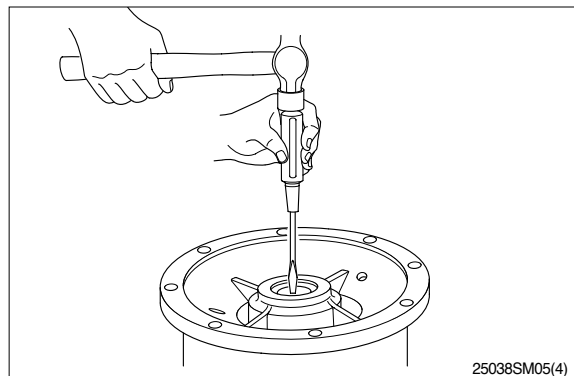

(17) Disassembly of cylinder assembly

Removal of inner race of taper roller bearing(3).

After removing snap ring(23), lift out cylinder(24) with 2 inner race of roller bearing(3) by applying gear puller at the end of spline in the cylinder.

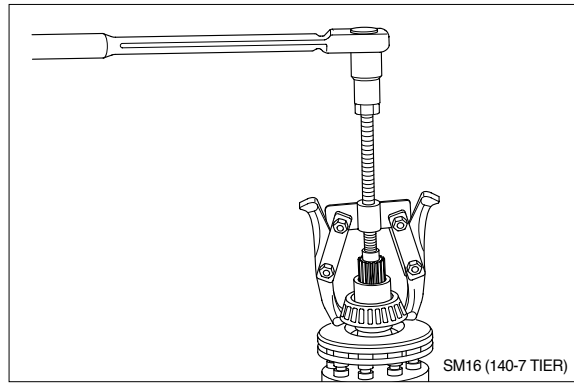

Separate cam plate(5), piston assembly (7), return plate(6) from cylinder(24).

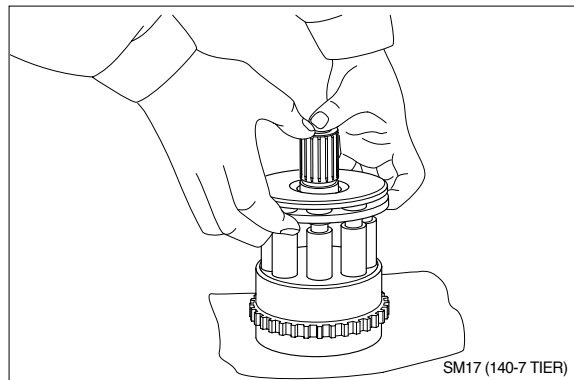

Get cam plate(5) slide on sliding face of piston assembly(7) and remove it. Be cautious not to damage on sliding face of cam plate.

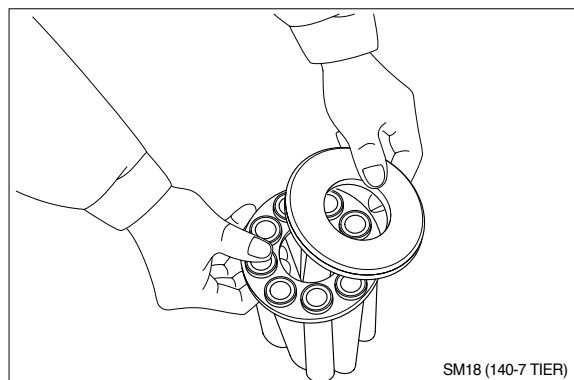

Remove backing spring(4) from cylinder (24).

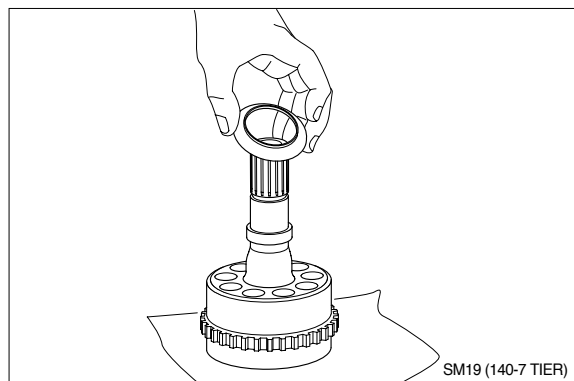

This completes disassembly.

3) ASSEMBLY

(1) Preparation

Before reassembling, perform below procedure.

Check each part for damage caused by using or disassembling. If damaged, eliminate damage by grinding with proper sandpaper, wash them with cleaning oil and dry with compressed air.

Replace seal with new one.

Grind sliding face of piston assembly(7), balance plate(21) and cam plate(5) with sandpaper #2000.

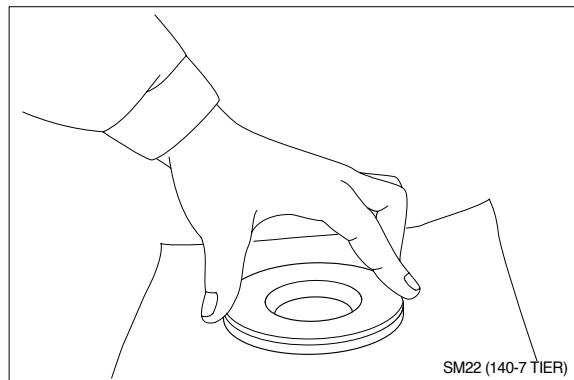
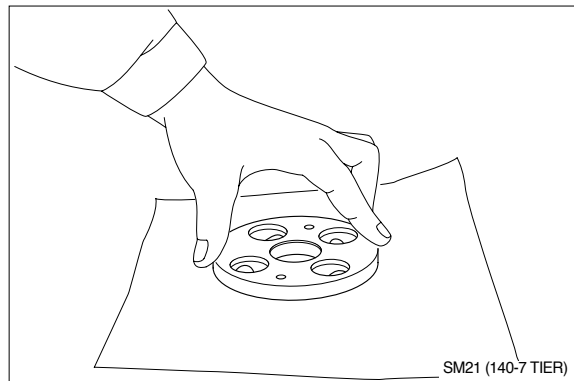
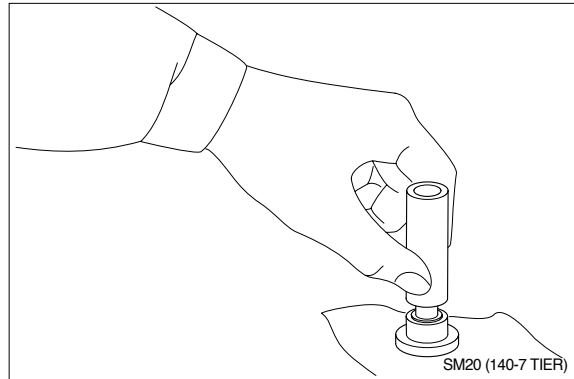

When assembling, lubricate with specified clean hydraulic oil.

When assembling piston assembly(7) to piston hole of cylinder(24), check matching mark between them.

(2) Cylinder assembly

Lubricate grease on round area (Contacting area with spring(4)) of cylinder(24) and assemble spring(4).

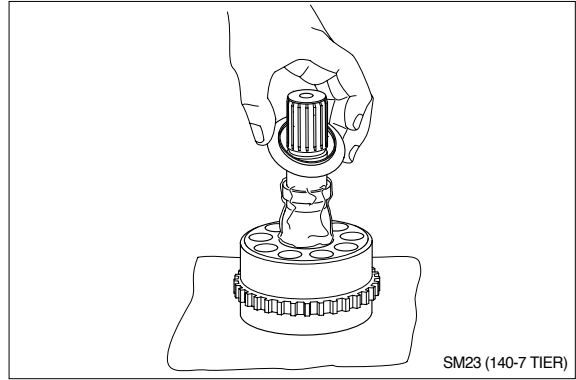

Insert piston assembly(7) in hole of return plate(6).

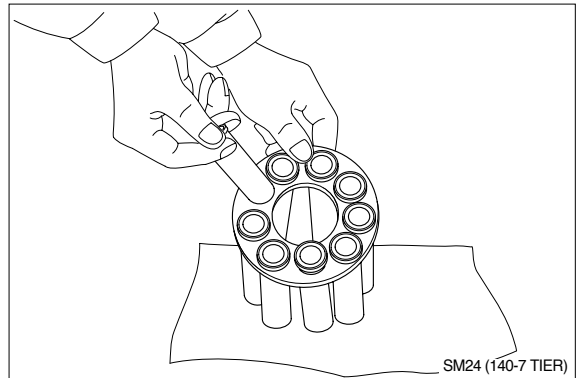

Assemble piston assembly(7) and return plate(6) to cylinder(24). When assembling, check matching mark between them. Before assembling, lubricate specified hydraulic oil in piston hole of cylinder(24).

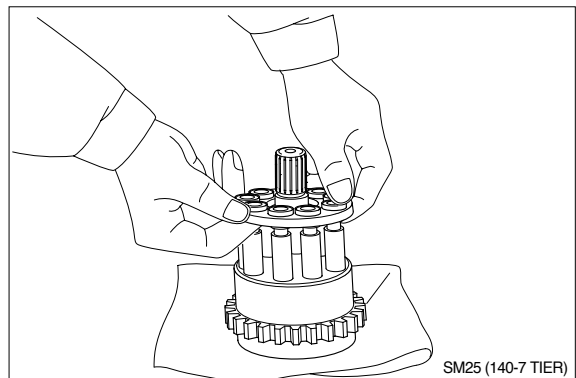

Lubricate specified hydraulic oil on shoe sliding face of piston assembly(7) and assemble cam plate(5).

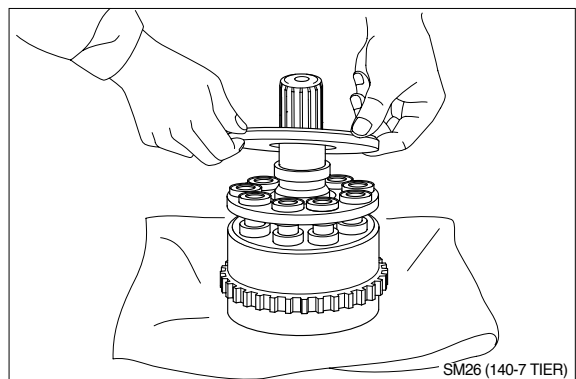

Assemble inner race of taper roller bearing(3) to cylinder(24).

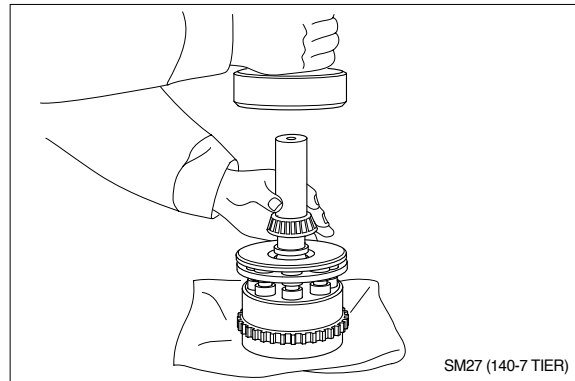

Apply loctite to bearing mounting area of inner race of cylinder(24) lightly.

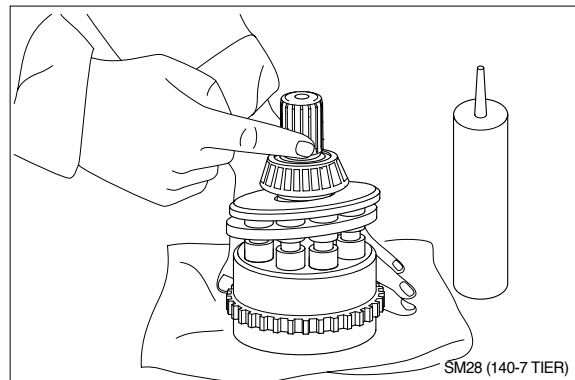

Assemble inner ring(1) to cylinder(24).

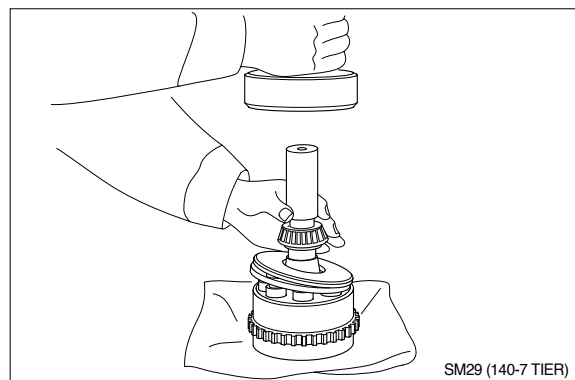

(3) Oil seal

Apply three bond of white color on outer surface of oil seal(2) and assemble and insert it.

Before assembling, lubricate lip of oil seal with grease.

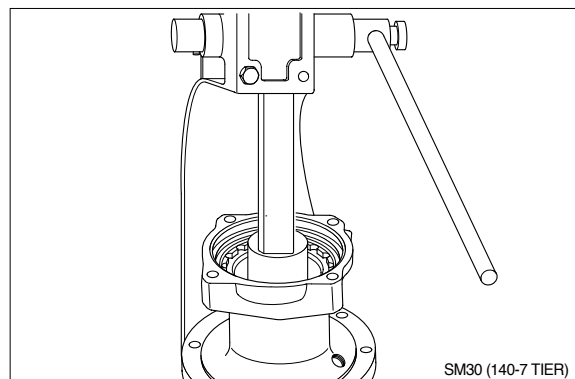

- (4) Assemble outer race of taper roller bearing(3) to motor housing(25).

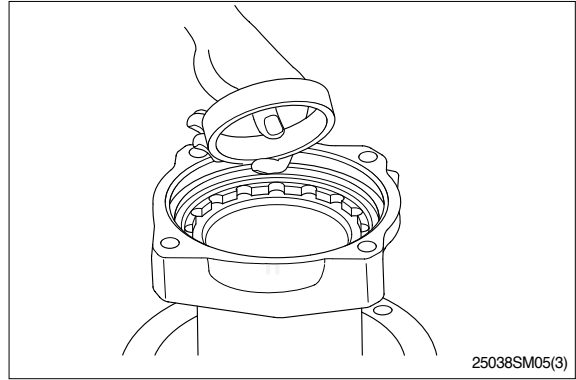

(5) Cylinder assembly

Hold end of cylinder assembly(24) with hands and assemble cylinder assembly to housing(25). Be careful to prevent damage of seal by spline of shaft. When assemble cylinder assembly, spline shaft of cylinder is protruded from end of housing, therefore put pads with length 30~50mm under bottom of housing.

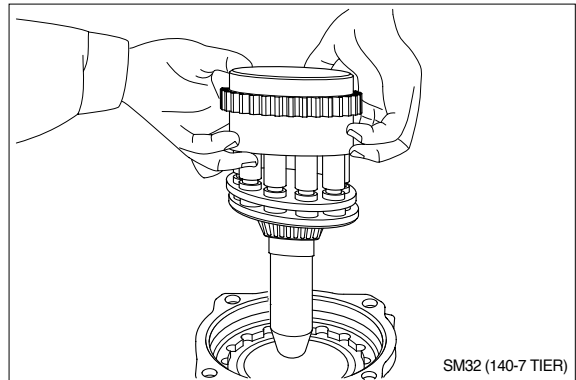

- (6) Assemble plate(9) and lining plate(8).
Lubricate specified hydraulic oil on each side.

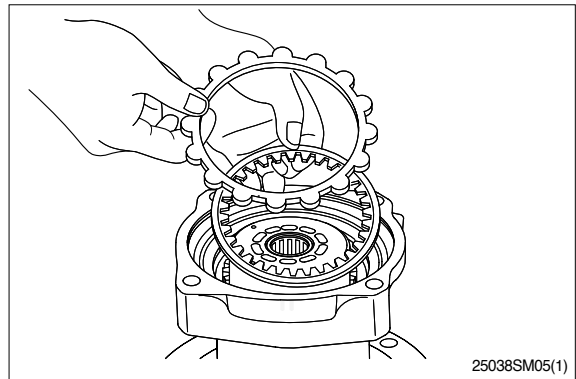

- (7) Insert O-rings(10,12) into housing(25) and piston(11).
Lubricate O-ring with grease.

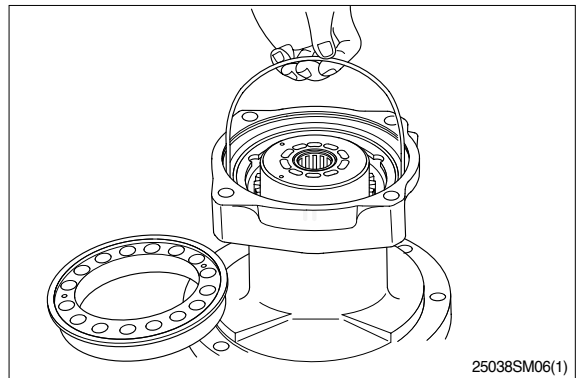

(8) Brake piston

Lubricate specified hydraulic oil on outer sliding face of piston(11) and assemble brake piston to housing(25).

It is too tight to assemble piston(7) because O-rings(10,12) are fitted, therefore it is recommended to push piston(11) horizontally by hands at once.

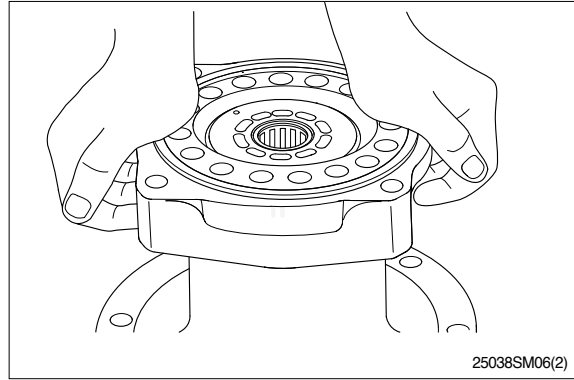

(9) Spring(13, brake unit)

Assemble spring(13) to piston(11) of brake unit.

Insert spring(13) into original position.

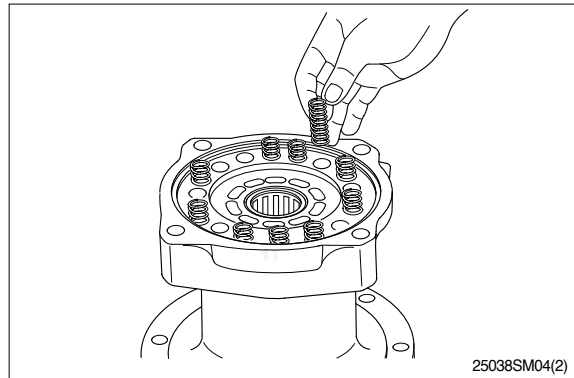

(10) Assemble bushing(20) with teflon ring(19) and scrowave(18) to bushing hole of cover(30).

Lubricate on both end surfaces of bushing(20) and outer face of teflon ring(19) with grease and assemble cover to housing, and parts are adhered on cover by grease viscosity which makes assembling easy.

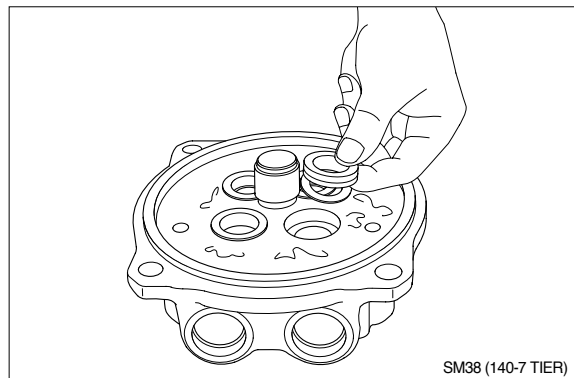

(11) Lubricate locating pin for antirotation of balance plate(21) of cover(30) with grease sufficiently and install locating pin to housing.

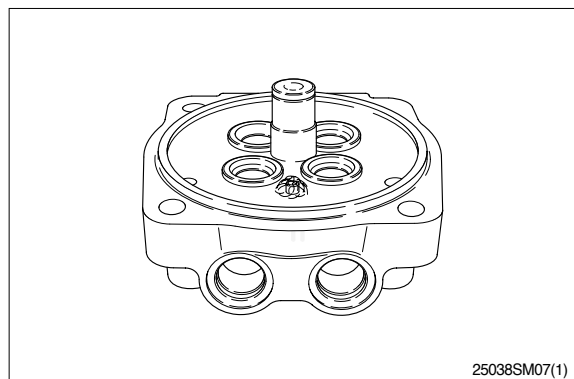

(12) Balance plate

Assemble balance plate(21) to cover(30).
Be cautious of assembling direction.

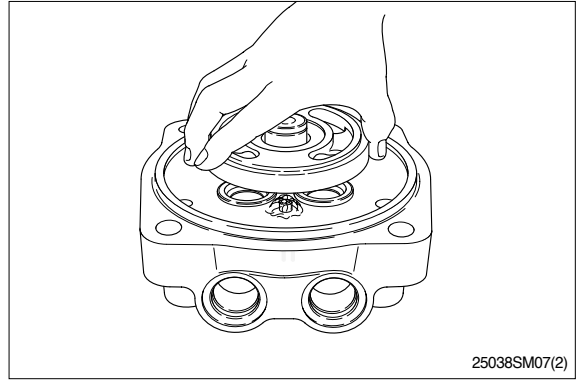

(13) Assemble inner race of needle bearing (22) and snap ring(23) to cover(30).

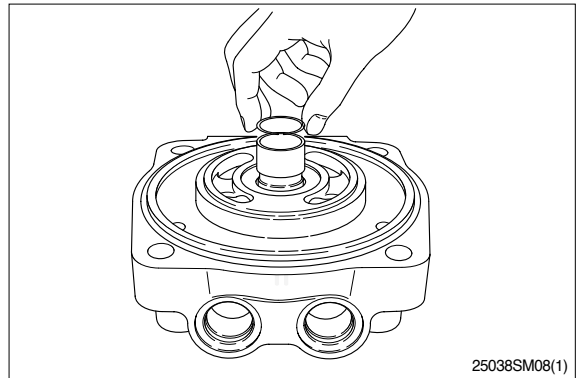

**(14) Assemble O-ring(12) to cover(30).
Lubricate O-ring with grease.**

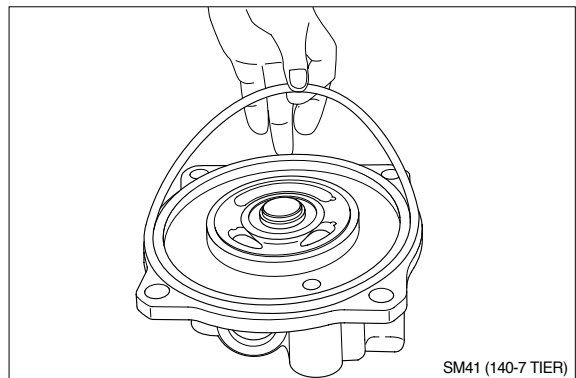

(15) Apply three bond of white color to distinguish oil leakage from remaining oil in bolt hole(M14) of cover(30).

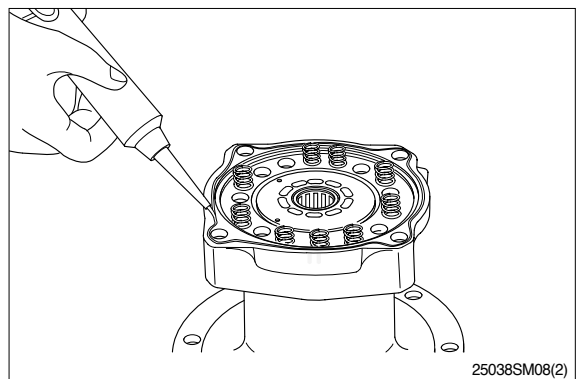

(16) Cover

Assemble cover(30) and balance plate (21) to housing(25) lightly, holding them up with hands.

When assembling, be careful not to detach balance plate(21) and bushing (20) from cover(30).

Fit matching marks on housing(25) and cover(30) made before disassembling.

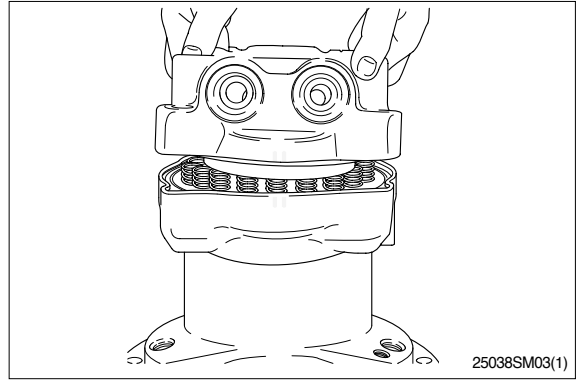

(17) Tighten cover(30) and housing(25) with 12mm hexagonal socket bolt(35).

- Tightening torque : 16kgf · m(116lbf · ft)

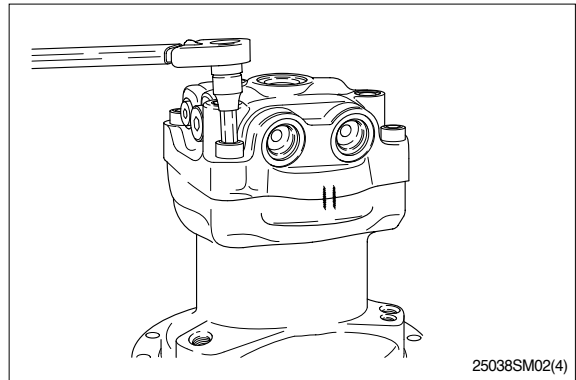

(18) Make up valve

Assemble check(40) and spring(41) to cover(30) and tighten cap(42) with 14mm hexagonal socket bolt.

- Tightening torque : 14kgf · m(101lbf · ft)

(19) Bypass valve assembly

Assemble bypass valve assembly(26) to cover(30) with 10mm hexagonal socket bolt.

- Tightening torque : 8kgf · m(58lbf · ft)

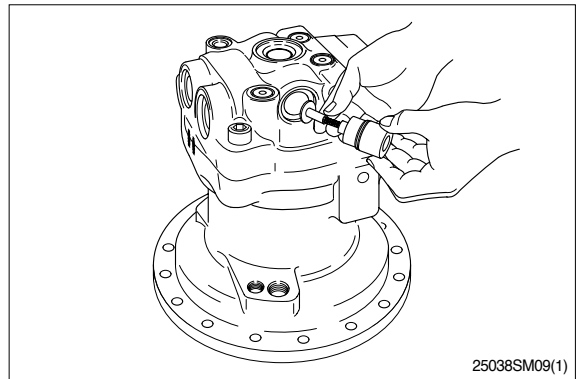

(20) Relief assembly

Assemble relief valve assembly(34) to cover(30) with 14mm hexagonal socket bolt.

- Tightening torque : 8kgf · m(58lbf · ft)

Be cautious of assembling method.

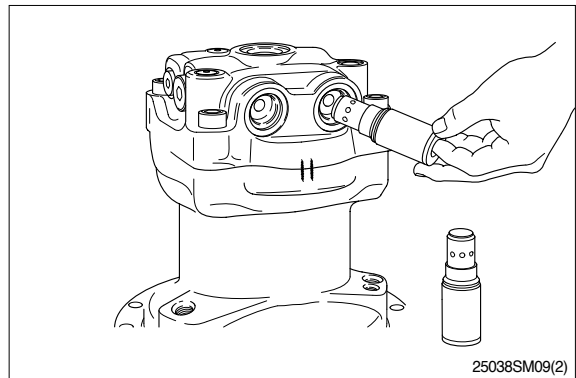

(21) Check of assembly

Load pilot pressure of 20kgf/cm² to brake release port after opening inlet and outlet port.

Check if output shaft is rotated smoothly around torque of 0.5~1kgf · m.

If not rotated, disassemble and check.

This completes assembly.

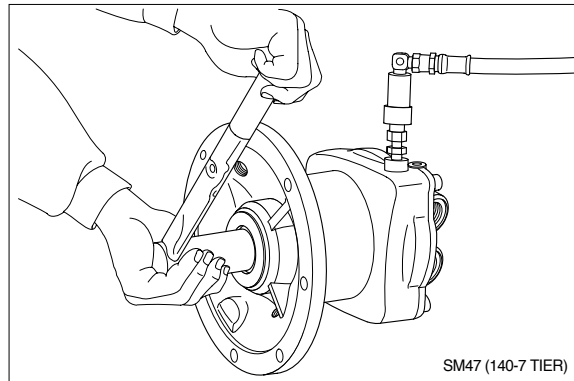

3. REMOVAL AND INSTALL OF REDUCTION GEAR

1) REMOVAL

- (1) Remove the swing motor assembly.
For details, see **removal of swing motor assembly**.
- (2) Sling reduction gear assembly(1) and remove mounting bolts(2).
- (3) Remove the reduction gear assembly.
 - Reduction gear device weight : 95kg
(209lb)



2) INSTALL

- (1) Carry out installation in the reverse order to removal.
 - Tightening torque : $29.7 \pm 4.5 \text{kgf} \cdot \text{m}$
($215 \pm 32.5 \text{lb} \cdot \text{ft}$)

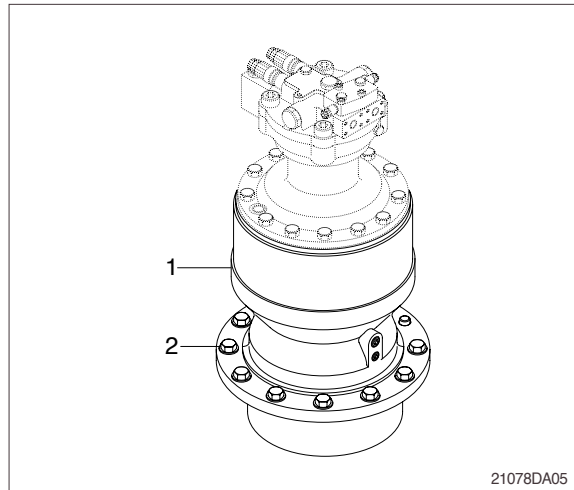

4. DISASSEMBLY AND ASSEMBLY OF REDUCTION GEAR

1) STRUCTURE

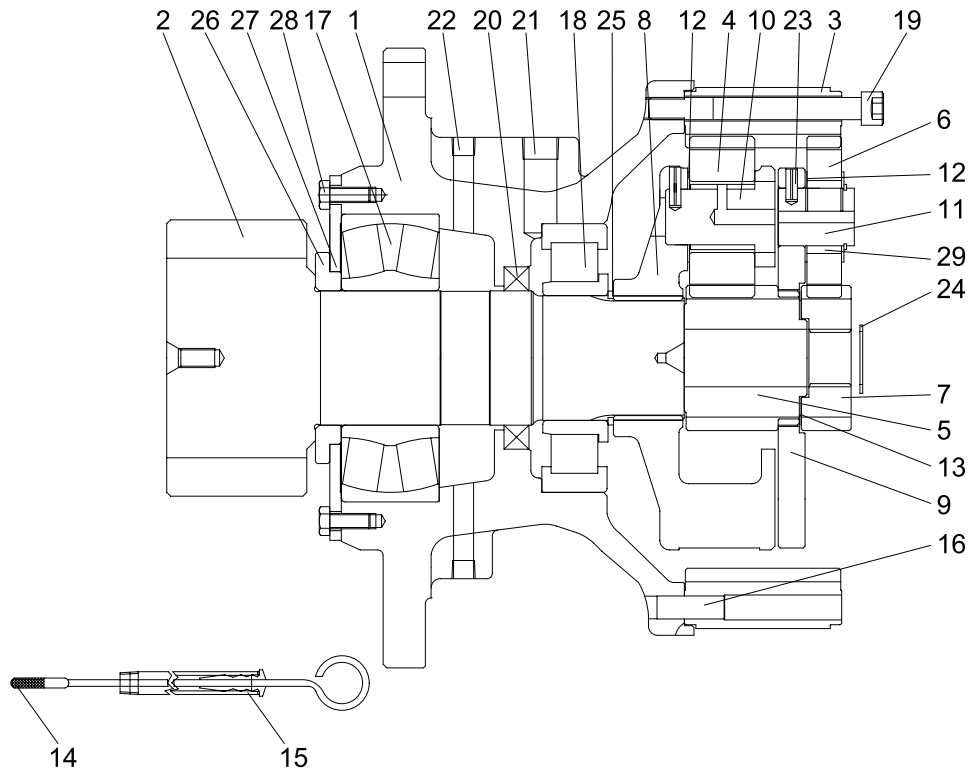

14072SF51

1	Casing	10	Pin No.2 assembly	20	Oil seal
2	Drive shaft	11	Pin No.1	21	Plug(B)
3	Ring gear	12	Thrust washer(B)	22	Plug(A)
4	Planet gear No.2	13	Thrust washer(A)	23	Spring pin
5	Sun gear No.2	14	Gage bar	24	Stop ring
6	Planet gear No.1	15	Gage pipe	25	Stop ring
7	Sun gear No.1	16	Knock pin	26	Spacer
8	Carrier No.2	17	Sph roller bearing	27	Cover plate
9	Carrier No.1	18	Cyl roller bearing	28	Bolt
		19	Bolt	29	Needle cage

2) DISASSEMBLY

- (1) Remove gauge bar(14) and gauge pipe (15) from the swing motor casing.
Pour the gear oil out of reduction gear into the clean bowl to check out the friction decrease.

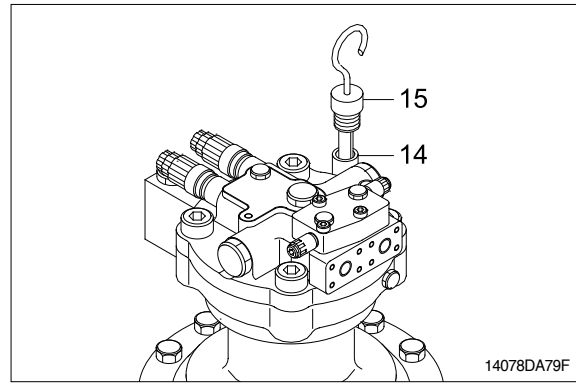

- (2) Loosen the socket bolts(19) to separate swing motor from reduction gear.

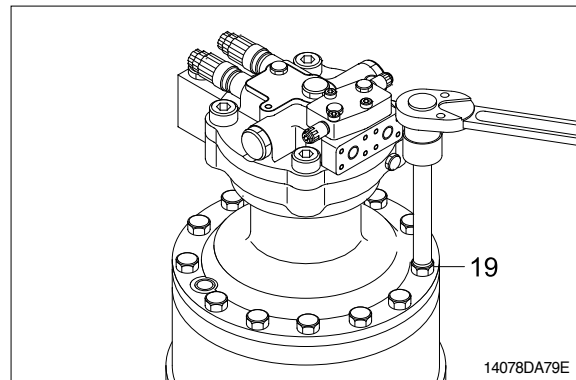

- (3) Remove stop ring(24) and then sun gear(7).

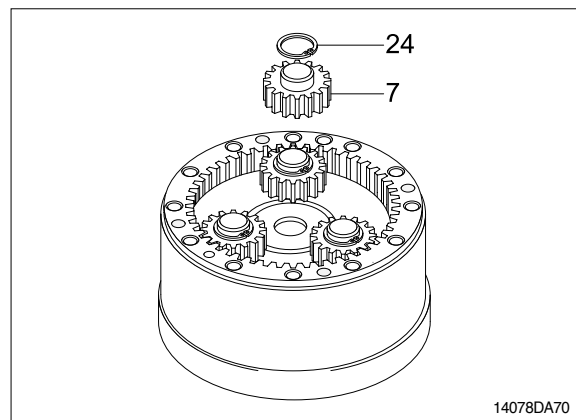

- (4) Tighten two M10 eye bolts to carrier(9) and lift up and remove carrier(9) as subassembly.

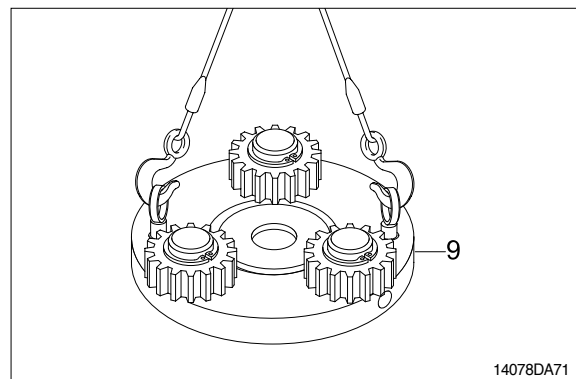

(5) Disassembling carrier1(9) assembly.

Remove stop ring(24).

Remove thrust washer(12), planet gear1 (6), needle cage(29), and thrust washer(12) from the carrier.

Using M8 solid drill, crush spring pin(23) so that the pin1(11) can be removed by hammering.

Do not reuse spring pin(23).

Do not remove pin1(11), carrier1(9) and spring pin(23) but in case of replacement.

Put matching marks on the planet gear1 (6) and the pin1(11) for easy reassembly.

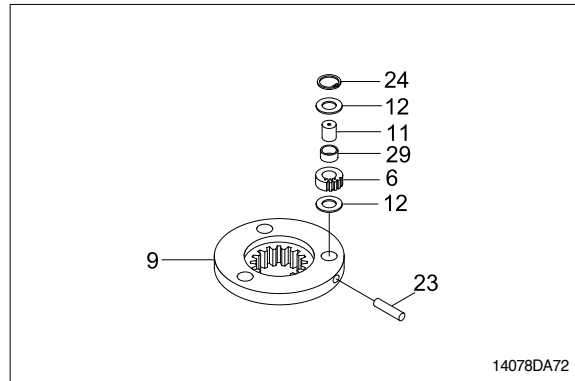

(6) Remove sun gear2(5) and thrust washer (13).

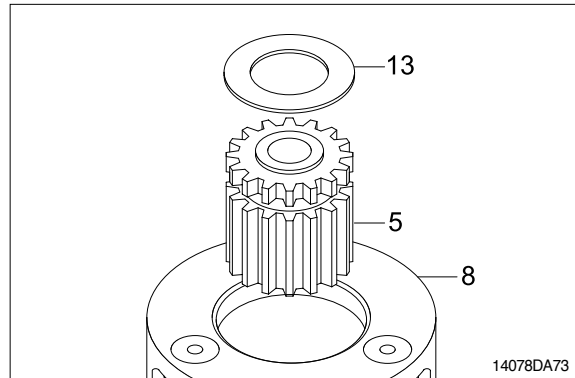

(7) Remove carrier2(8) assembly from casing (1).

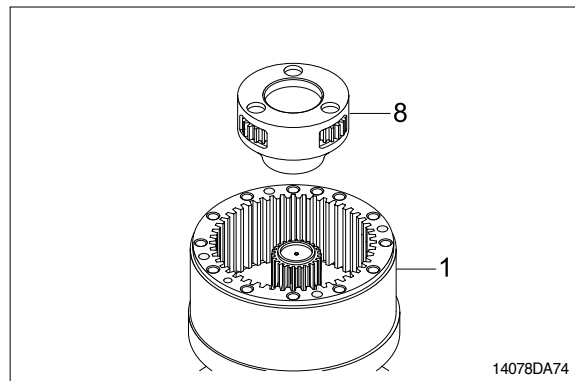

(8) Disassembling carrier2(8) assembly

Using M8 solid drill, crush spring pin(23) so that the pin2(10) can be removed.

Do not reuse spring pin(23).

Remove pin2(10), planet gear2(4) and thrust washer(12) from the carrier2(8).

Put matching marks on the planet gear2 (4) and the pin2(23) for easy reassembly.

Do not disassemble pin2(23), carrier2(8) and spring pin(23) but in case of replacement.

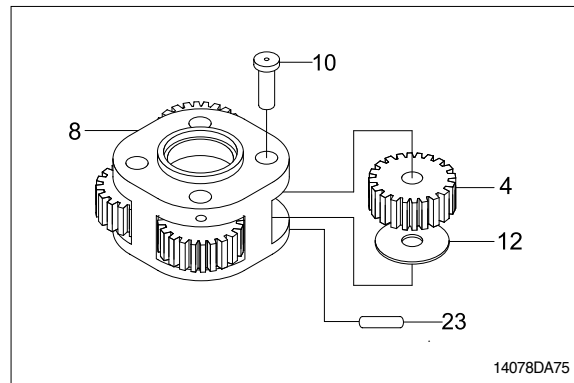

(9) Tighten two M16 eyebolt to the ring gear(3) and then lift the ring gear(3) out of casing(1).

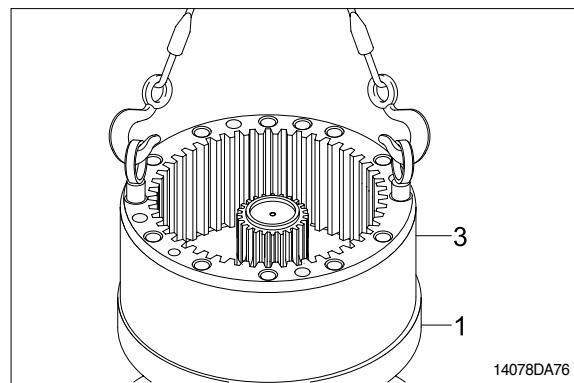

(10) Remove stop ring (25) from the drive shaft(2).

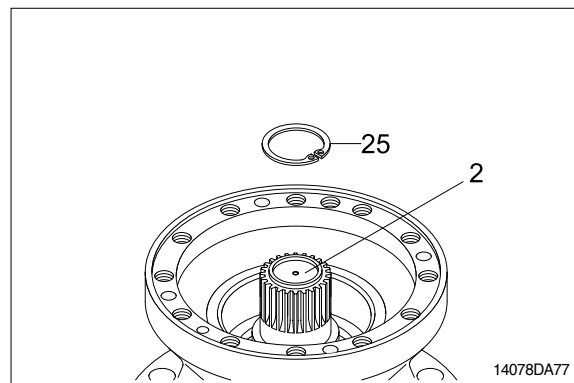

(11) Remove drive shaft(2) with roller bearing(18) and oil seal(20) assembled. Remove knock pin(16) from the casing(1).

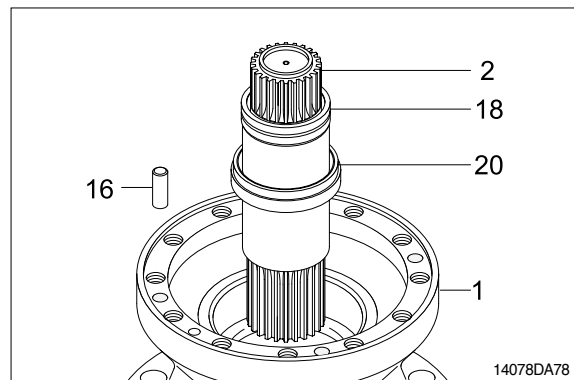

- (12) Remove roller bearing(18) and oil seal(20) from the drive shaft(2).
Do not reuse oil seal(20) once removed.

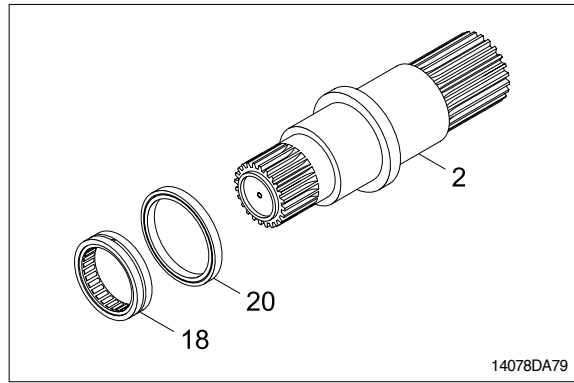

- (13) Using the bearing disassembly tool, remove roller bearing(17).

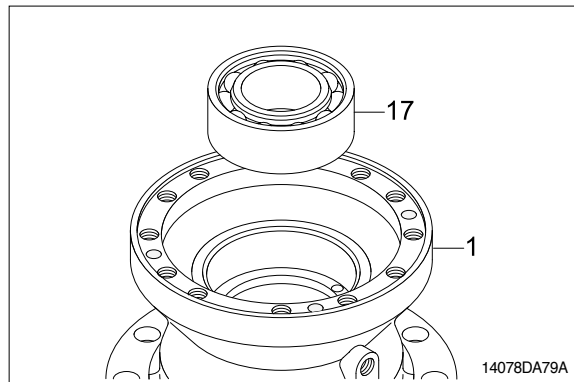

- (14) Remove plugs(21, 22) from the casing(1).

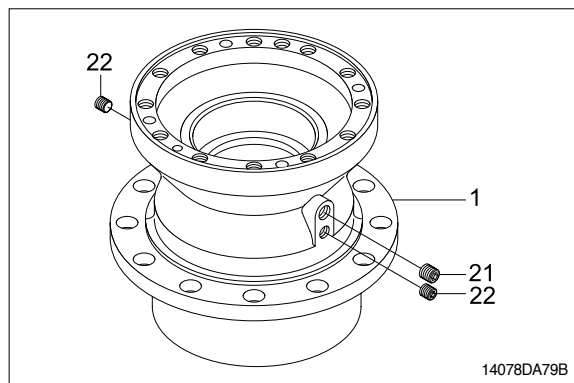

3) ASSEMBLY

- (1) Assemble roller bearing(17) inside the casing(1).

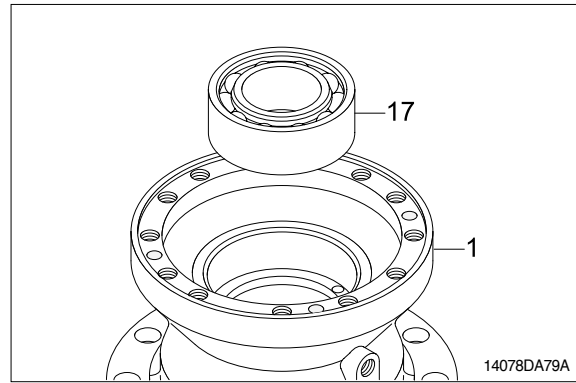

- (2) Assemble the drive shaft(2) into the casing(1) and then install oil seal(20) and roller bearing(18).

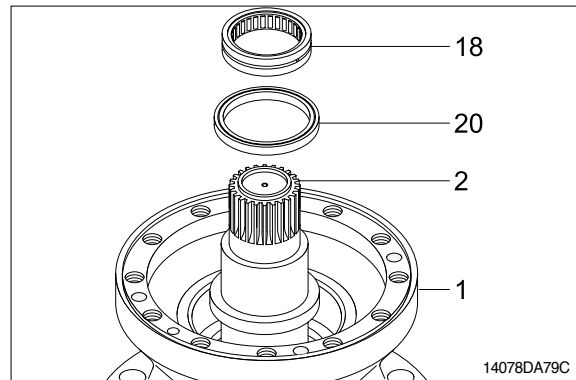

- (3) Install stop ring(25) on top of drive shaft (2).

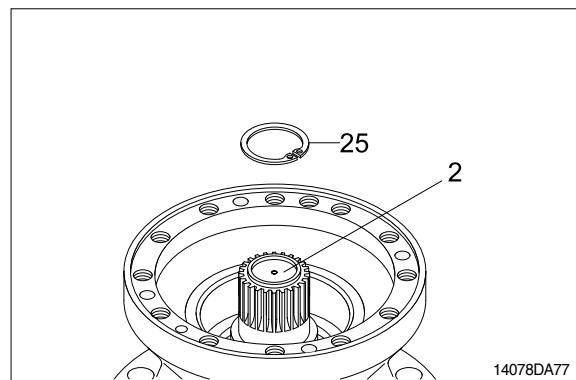

- (4) Apply loctite to the tapped holes of casing (1).
- (5) Tighten 2 M16 eye bolts to the ring gear(3) and lift up and then assemble it onto the casing(1). Don't fail to coincide the knock pin(16) holes.

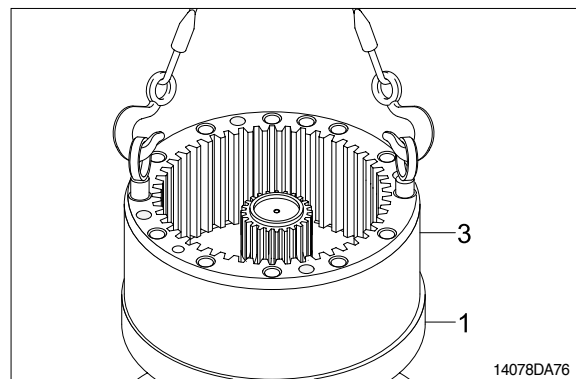

- (6) Assembling carrier2(8) assembly.
 Install thrust washer(12) and the planet gear2(4) inside the carrier2(8).
 Assemble the pin2(10) to the carrier2(8) and then press the spring pin(23) by hammering.
 Punch 2 points of the spring pin(23) lip.
 Take care not to mistake the matching marks of each part.

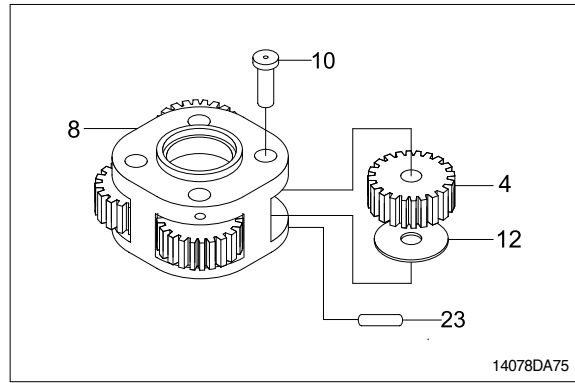

- (7) Assemble carrier2(8) assembly correctly to the drive shaft(2).

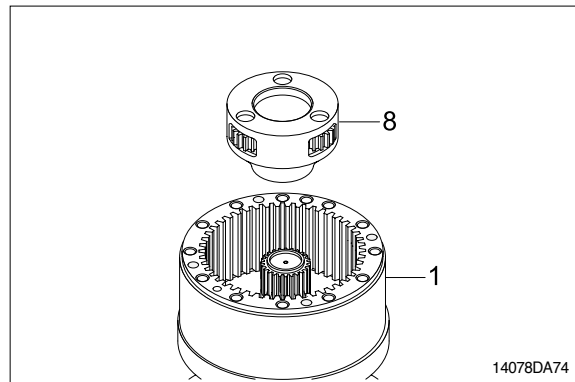

- (8) Assemble sun gear2(5) and thrust gear (13) to the center of the carrier2(8) assembly.

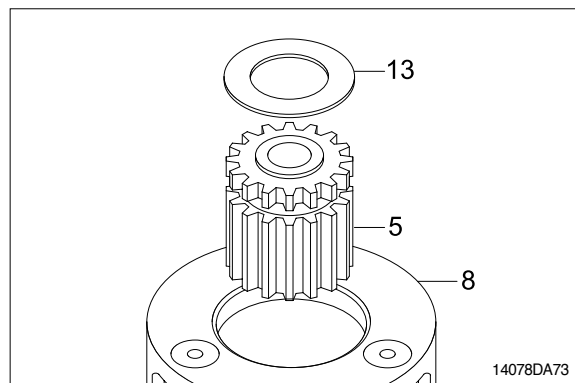

- (9) Assembling carrier1(9) assembly.
 Assemble the pin1(11) to the carrier1(9) and then press the spring pin(23) by hammering.
 Punch 2 points of the spring pin's(23) lip.
 Install needle cage(29) into the planet gear1(6).
 Assemble thrust washer(12), planet gear1(6), and then stop ring(24) to the pin1(11).
 Take care not to mistake the matching marks of each part.

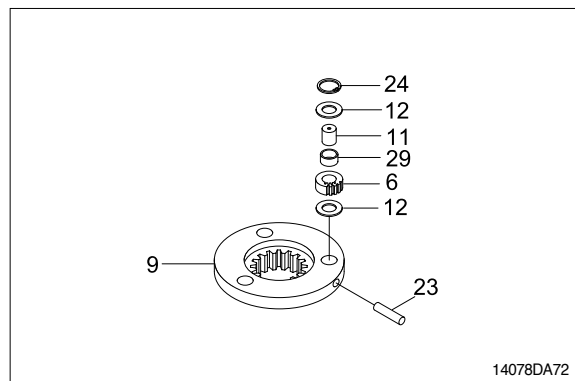

(10) Assemble carrier(9) assembly into the ring gear.

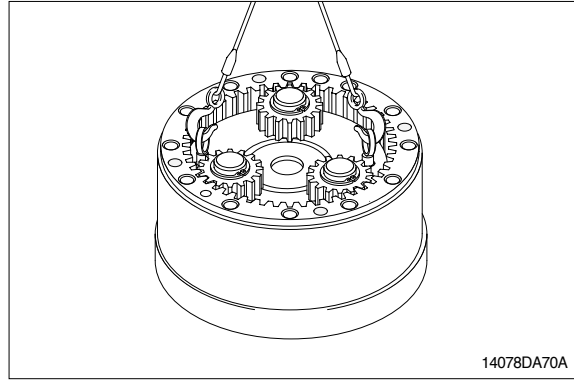

(11) Hammer 4 knock pins(16) around the ring gear(3).

(12) Assemble sun gear(7) and stop ring(24) to the drive shaft of the swing reduction gear.

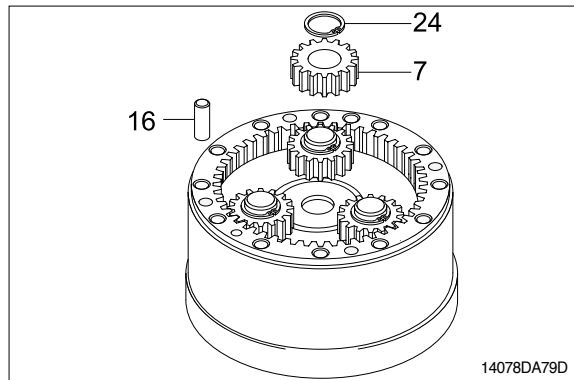

(13) Apply loctite to the tapped holes of the ring gear(3) and then mount swing motor onto the ring gear(3).
Don't fail to coincide the gauge bar(14) hole.

(14) Tighten socket bolts(19) around the swing motor assembly.
· Tightening torque : 24kgf · m(173lbf · ft)

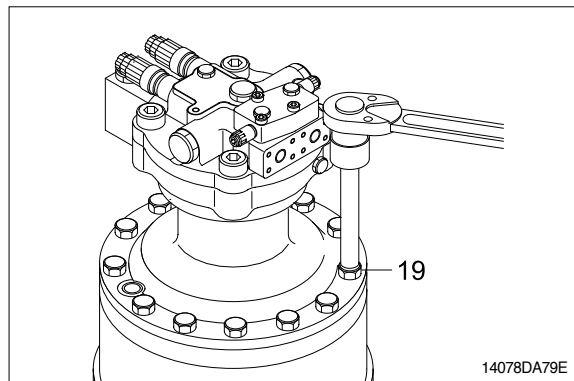

(15) Assemble plugs(21, 22), gauge bar(14) and gauge pipe(15).

