

GROUP 2 MODE SELECTION SYSTEM

1. POWER MODE SELECTION SYSTEM

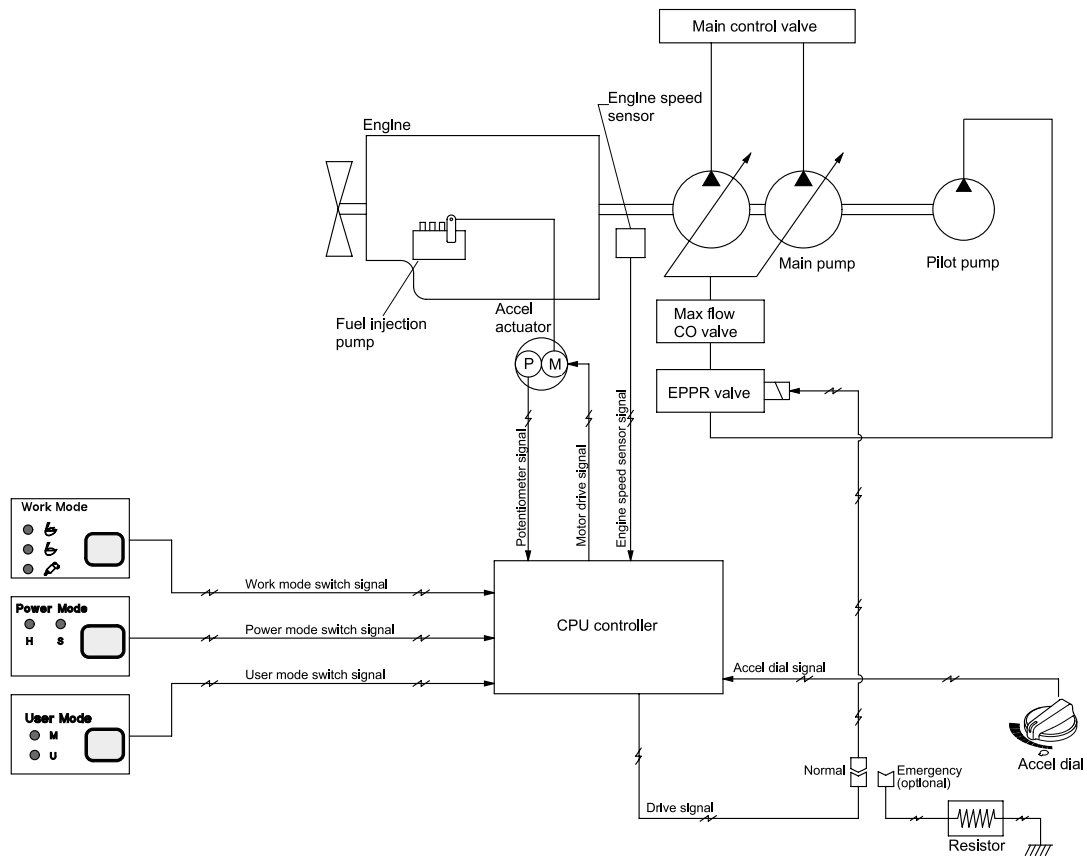

14W75MS02

Mode selection system(Micro computer based electro-hydraulic pump and engine mutual control system) optimizes the engine and pump performance.

The combination of 2 power modes(H, S) and accel dial position(10 set) makes it possible to use the engine and pump power more effectively corresponding to the work conditions from a heavy and great power requesting work to a light and precise work.

Mode	Application	Engine rpm				Power shift by EPPR valve			
		Default		Other case		Default		Other case	
		Unload	Load	Unload	Load	Current (mA)	Pressure (kgf/cm ²)	Current (mA)	Pressure (kgf/cm ²)
M	Maximum power	2350	2100	2350	2100	235 ± 30	-	210	3.6
H	High power	2200 ± 50	2000	2200	2000	320 ± 30	10	210	3.6
S	Standard power	2100 ± 50	1900	2100	1900	390 ± 30	15	320	10
AUTO DECEL	Engine deceleration	1200 ± 100	-	1200 ± 100	-	600 ± 30	31	600 ± 30	31
One touch decel	Engine quick deceleration	950 ± 100	-	950 ± 100	-	700 ± 30	35	700 ± 30	35
KEY START	Key switch start position	950 ± 100	-	950 ± 100	-	700 ± 30	35	700 ± 30	35

2. WORK MODE SELECTION SYSTEM

3 work modes can be selected for the optional work speed of the machine operation.

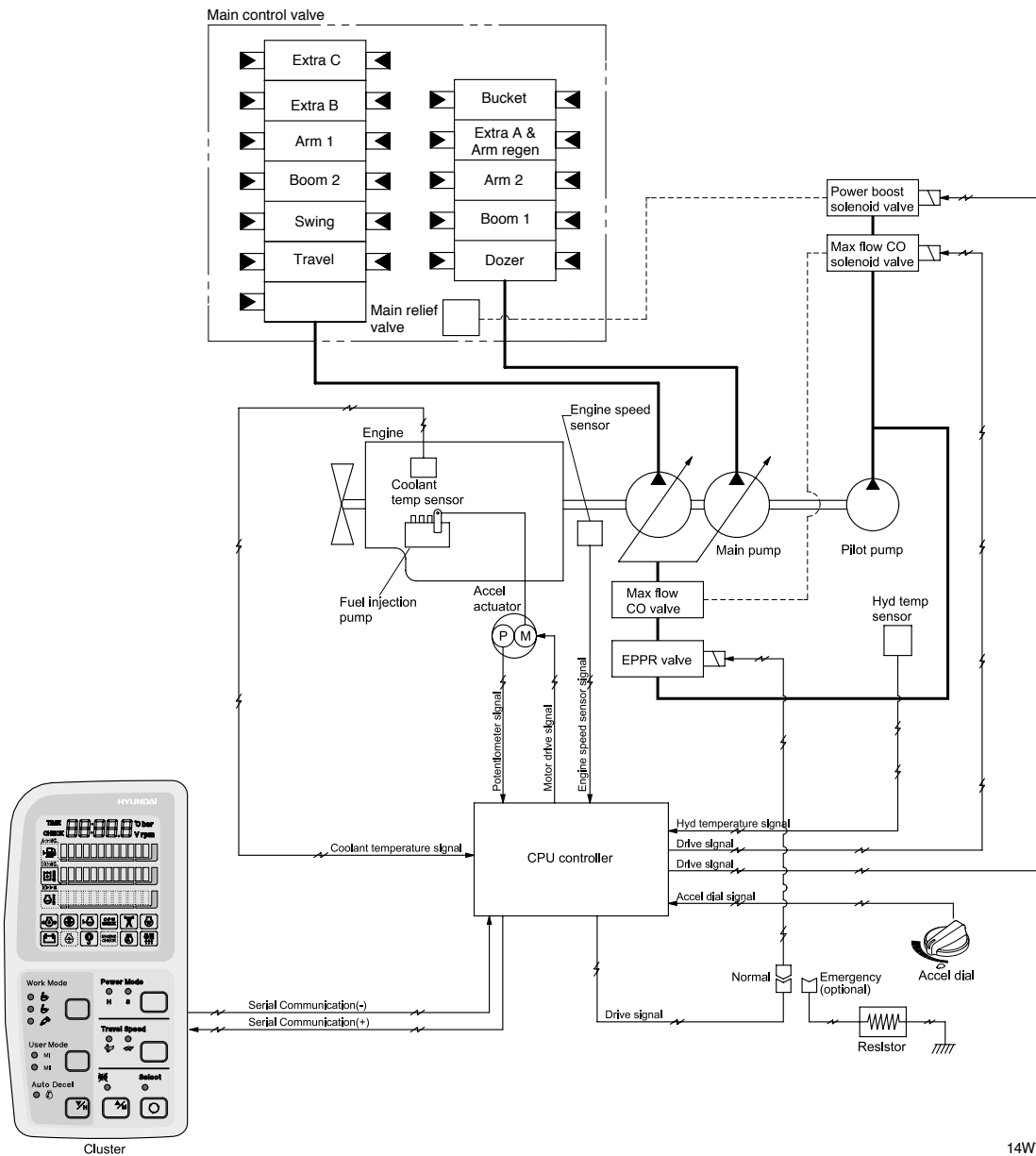

14W75MS03

1) HEAVY DUTY WORK MODE

The arm regeneration cut off solenoid is deactivated to make the arm operation speed faster.

2) GENERAL WORK MODE

When key switch is turned ON, this mode is selected and controllability is better than heavy duty work mode.

3) BREAKER OPERATION MODE

It sets the pump flow to the optimal operation of breaker by activating the max flow cut-off solenoid.

Work mode	Arm regeneration cut off solenoid	Max flow cut-off solenoid
Heavy duty	OFF	OFF
General	ON	OFF
Breaker	OFF	ON

3. USER MODE SELECTION SYSTEM

An operator can change the engine and pump power and memorize it for his preference.

Mode	Operation
U	High idle rpm, auto decel rpm and EPPR pressure can be modulated and memorized separately

HOW TO MODULATE THE MEMORY SET

- 1) U mode has a initial set which are mid-range of max engine speed, auto decel rpm, and EPPR valve input current. When you select U, cluster LCD displays.
- 2) To change the engine high idle speed, press the USER mode switch and SELECT switch at the same time and then ACCEL blinks at 0.5 seconds interval.
 - By pressing ▲ or ▼ switch, █ will increase or decrease.
- 3) To change DECEL rpm, press the USER mode switch and SELECT switch once more and then DECEL blinks at 0.5 seconds interval.
 - By pressing ▲ or ▼ switch, █ will increase or decrease.
- 4) To change EPPR current, press the USER mode switch and SELECT switch one more and then EPPR blinks at 0.5 seconds interval.
 - By pressing ▲ or ▼ switch, █ will increase or decrease.

· LCD segment vs parameter setting

Segment (█)	ACCEL (rpm)	DECEL (rpm)	EPPR (mA)
1	High idle-900	Low idle	150
		950	
2	High idle-800	1050	200
3	High idle-700	1100	250
4	High idle-600	1150	300
5	High idle-500	Decel rpm	350
		1200	
6	High idle-400	1250	400
7	High idle-300	1300	450
8	High idle-200	1350	500
9	High idle-100	1400	550
10	High idle	1500	600

- 5) To memorize the final setting, press the USER mode switch and SELECT switch one more time.

